

TECHNICAL DATA & SERVICE MANUAL

Euro-Line®

OUTDOOR UNIT: AER608SCL
AER609SCL
AER612SCL

SPLIT SYSTEM AIR CONDITIONER

Model No.	Product Code No.
AER608SCL	387007127
AER609SCL	387007128
AER612SCL	387007129

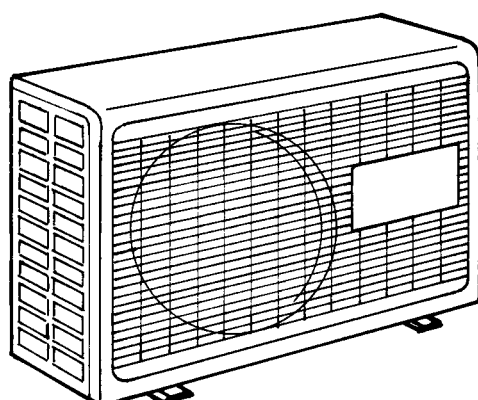

IMPORTANT! **Please read before installation**

This air conditioning system meets strict safety and operating standards.

For the installer or service person, it is important to install or service the system so that it operates safely and efficiently.

For safe installation and trouble-free operation, you must:

- Carefully read this instruction booklet before beginning.
- Follow each installation or repair step exactly as shown.
- Observe all local, state and national electrical codes.
- Pay close attention to all warning and caution notices given in this manual.
- The unit must be supplied with a dedicated electrical line.



WARNING

This symbol refers to a hazard or unsafe practice which can result in severe personal injury or death.



CAUTION

This symbol refers to a hazard or unsafe practice which can result in personal injury or product or property damage.

If necessary, get help

These instructions are all you need for most installation sites and maintenance conditions.

If you require help for a special problem, contact our sale/service outlet or your certified dealer for additional instructions.

In case of improper installation

The manufacturer shall in no way be responsible for improper installation or maintenance service, including failure to follow the instructions in this document.

SPECIAL PRECAUTIONS

- During installation, connect before the refrigerant system and then the wiring one; proceed in the reverse order when removing the units.

WARNING

When wiring



ELECTRICAL SHOCK CAN CAUSE SEVERE PERSONAL INJURY OR DEATH. ONLY A QUALIFIED, EXPERIENCED ELECTRICIANS SHOULD ATTEMPT TO WIRE THIS SYSTEM.

- Do not supply power to the unit until all wiring and tubing are completed or reconnected and checked, to ensure the grounding.
- Highly dangerous electrical voltages are used in this system. Carefully refer to the wiring diagram and these instructions when wiring. Improper connections and inadequate grounding can cause **accidental injury and death.**

- **Ground the unit** following local electrical codes.
- The Yellow/Green wire cannot be used for any connection different from the ground connection.
- Connect all wiring tightly. Loose wiring may cause overheating at connection points and a possible fire hazard.
- Do not allow wiring to touch the refrigerant tubing, compressor, or any moving parts of the fan.
- Do not use multi-core cable when wiring the power supply and control lines. Use separate cables for each type of line.

When transporting

Be careful when picking up and moving the indoor and outdoor units. Get a partner to help, and bend your knees when lifting to reduce strain on your back. Sharp edges or thin aluminium fins on the air conditioner can cut your fingers.

When installing...

... In a ceiling or wall

Make sure the ceiling/wall is strong enough to hold the unit-weight. It may be necessary to build a strong wooden or metal frame to provide added support.

... In a room

Properly insulate any tubing run inside a room to prevent "sweating", which can cause dripping and water damage to walls and floors.

... In moist or uneven locations

Use a raised concrete base to provide a solid level foundation for the outdoor unit.

This prevents damage and abnormal vibrations.

... In area with strong winds

Securely anchor the outdoor unit down with bolts and a metal frame. Provide a suitable air baffle.

... In a snowy area (for heat pump-type systems)

Install the outdoor unit on a raised platform that is higher than drifting snow. Provide snow vents.

When connecting refrigerant tubing

- Keep all tubing runs as short as possible.
- Use the flare method for connecting tubing.
- Apply refrigerant lubricant to the matching surfaces of the flare and union tubes before connecting them; screw by hand and then tighten the nut with a torque wrench for a leak-free connection.
- Check carefully for leaks before starting the test run.

NOTE:

Depending on the system type, liquid and gas lines may be either narrow or wide. Therefore, to avoid confusion, the refrigerant tubing for your particular model is specified as narrow tube for liquid, wide tube for gas.

When servicing

- Turn the power OFF at the main power board before opening the unit to check or repair electrical parts and wiring.
- Keep your fingers and clothing away from any moving parts.
- Clean up the site after the work, remembering to check that no metal scraps or bits of wiring have been left inside the unit being serviced.
- Ventilate the room during the installation or testing the refrigeration system; make sure that, after the installation, no gas leaks are present, because this could produce toxic gas and dangerous if in contact with flames or heat-sources.

Table of Contents

	Page
1. OPERATING RANGE	4
<hr/>	
2. SPECIFICATIONS	5
2-1 Unit specifications	5
2-2 Major Component specifications	8
2-3 Other Component specifications	11
<hr/>	
3. DIMENSIONAL DATA	12
<hr/>	
4. REFRIGERANT FLOW DIAGRAM	13
<hr/>	
5. PERFORMANCE DATA	14
5-1 Performance Charts	14
5-2 Cooling Capacity	17
<hr/>	
6. ELECTRICAL DATA	20
6-1 Electrical characteristics	20
6-2 Electric Wiring Diagram	21
6-3 System Wiring Diagram	21

1. OPERATING RANGE

	Temperature	Indoor Air Intake Temp.	Outdoor Air Intake Temp.
Cooling	Maximum	32°C D.B. / 23°C W.B.	43°C D.B.
	Minimum	19°C D.B. / 14°C W.B.	-15°C D.B.

2. SPECIFICATIONS

2-1 Unit Specifications

AER608SCL

Power source	220 - 240 V ~ 50 Hz
--------------	---------------------

Voltage rating	230 V
----------------	-------

Performance *	AWR608CL	Cooling
Capacity	kW	1,90
	BTU/h	6485
Air circulation (High)	m ³ /h	430
Moisture removal (High)	Liters/h	0,40

Electrical Rating		Cooling
Available voltage range	V	198 ~ 264
Running amperes	A	3,20
Power input	W	680
Power factor	%	92
C.O.P.	W/W	2,8
Compressor locked rotor amperes	A	17

Features		
Fan speed		1(Hi)
Compressor		Rotary (Hermetic)
Refrigerant / Amount charged at shipment	g	R407C / 730
Refrigerant control		Capillary tube
Operation Sound	Hi	dB-A
		57
Refrigerant tubing connections		Flare type
Max. allowable tubing length at shipment	m	7.5
Refrigerant tube diameter	Narrow tube	mm(in.)
	Wide tube	mm(in.)
		6,35 (1/4)
		9,52 (3/8)

Dimensions & Weight			
Unit dimensions	Height	mm	540
	Width	mm	700
	Depth	mm	265
Package dimensions	Height	mm	568
	Width	mm	815
	Depth	mm	343
Weight	Net	kg	34
	Shipping	kg	37
Shipping volume		m ³	0,16

DATA SUBJECT TO CHANGE WITHOUT NOTICE

Remarks:

Rating conditions are:

Cooling: Indoor air temperature 27°C D.B. / 19°C W.B.

Outdoor air temperature 35°C D.B. / 24°C W.B.

* For other INDOOR UNITS' MODELS, please refer to catalogue

AER609SCL

Power source	220 - 240 V ~ 50 Hz
---------------------	---------------------

Voltage rating	230 V
-----------------------	-------

Performance *	AWR609CL	Cooling
Capacity	kW	2,60
	BTU/h	8874
Air circulation (High)	m ³ /h	450
Moisture removal (High)	Liters/h	0,80

Electrical Rating		Cooling
Available voltage range	V	198 ~ 264
Running amperes	A	4,40
Power input	W	990
Power factor	%	98
C.O.P.	W/W	2,6
Compressor locked rotor amperes	A	23

Features		
Fan speed		1(Hi)
Compressor		Rotary (Hermetic)
Refrigerant / Amount charged at shipment	g	R407C / 800
Refrigerant control		Capillary tube
Operation Sound	Hi	dB-A
		57
Refrigerant tubing connections		Flare type
Max. allowable tubing length at shipment	m	7.5
Refrigerant tube diameter	Narrow tube	mm(in.)
	Wide tube	mm(in.)
		6,35 (1/4)
		9,52 (3/8)

Dimensions & Weight			
Unit dimensions	Height	mm	540
	Width	mm	700
	Depth	mm	265
Package dimensions	Height	mm	568
	Width	mm	815
	Depth	mm	343
Weight	Net	kg	36
	Shipping	kg	39
Shipping volume		m ³	0,16

DATA SUBJECT TO CHANGE WITHOUT NOTICE

Remarks:

Rating conditions are:

Cooling: Indoor air temperature 27°C D.B. / 19°C W.B.

Outdoor air temperature 35°C D.B. / 24°C W.B.

* For other INDOOR UNITS' MODELS, please refer to catalogue

AER612SCL

Power source	220 - 240 V ~ 50 Hz
---------------------	---------------------

Voltage rating	230 V
-----------------------	-------

Performance *		AWR612CL	Cooling
Capacity		kW	3,40
		BTU/h	11604
Air circulation (High)		m ³ /h	470
Moisture removal (High)		Liters/h	1,50

Electrical Rating		Cooling
Available voltage range	V	198 ~ 264
Running amperes	A	6,30
Power input	W	1380
Power factor	%	95
C.O.P.	W/W	2,5
Compressor locked rotor amperes	A	33

Features			
Fan speed			1(Hi)
Compressor			Rotary (Hermetic)
Refrigerant / Amount charged at shipment		g	R407C / 750
Refrigerant control			Capillary tube
Operation Sound	Hi	dB-A	59
Refrigerant tubing connections			Flare type
Max. allowable tubing length at shipment		m	7.5
Refrigerant tube diameter	Narrow tube	mm(in.)	6,35 (1/4)
	Wide tube	mm(in.)	12,7 (1/2)

Dimensions & Weight			
Unit dimensions	Height	mm	540
	Width	mm	700
	Depth	mm	265
Package dimensions	Height	mm	568
	Width	mm	815
	Depth	mm	343
Weight	Net	kg	37
	Shipping	kg	40
Shipping volume		m ³	0,16

DATA SUBJECT TO CHANGE WITHOUT NOTICE

Remarks:

Rating conditions are:

Cooling: Indoor air temperature 27°C D.B. / 19°C W.B.

Outdoor air temperature 35°C D.B. / 24°C W.B.

* For other INDOOR UNITS' MODELS, please refer to catalogue

2-2 Major Component Specifications

Outdoor Unit: **AER608SCL**

Controller PCB	
Part No.	POW-CL128E
Control circuit fuse	250 V 3,15 A

Compressor	
Type	Rotary (Hermetic)
Compressor model	802 060 35B C-1RN60H5C
Nominal output	W 600
Compressor oil...Amount	cc FV68S...350
Coil resistance (Ambient temp. 25°C)	Ω C-R: 4,66 C-S: 8,89
Overload relay	External (OLR A) External (OLR T)
Safety devices	Type MRA 38072-3229 CS-7C115
Operating Temp. Open	°C 145 ± 5 115 ± 3
Close	°C 69 ± 11 95 ± 5
Operating amp. (Ambient temp. 25°C)	Trip in 6 to 16 s at 13 A //
Run capacitor	μF 17,5
	VAC 450

Fan & Fan Motor	
Type	Propeller
Q'ty Dia.	1... Ø 370
Fan motor model...Q'ty	K35410-M01846...1
No. Of poles...rpm (230 V, High)	4...782
Nominal output	W 19
Coil resistance (Ambient temp. 25 °C)	Ω BLK-WHT: 211÷242 WHT-VLT: 244÷281 VLT-YEL: 83,5÷96,1 BLK-PNK: 41,7÷48,0
Safety devices	Type Thermal protector
Operating temp. Open	°C 150 ± 10
Close	°C Automatic
Run capacitor	μF 1,5
	VAC 450

Heat Exch. Coil	
Coil	Aluminium plate fin / Copper tube
Rows	1
Fin pitch	mm 1,3
Face area	m ² 0,353

External Finish	
	Acrylic baked-on enamel finish

DATA SUBJECT TO CHANGE WITHOUT NOTICE

Outdoor Unit: **AER609SCL**

Controller PCB	
Part No.	POW-CL128E
Control circuit fuse	250 V 3,15 A

Compressor			
Type	Rotary (Hermetic)		
Compressor model	802 282 45G C-RN80H5A		
Nominal output	W	800	
Compressor oil...Amount	cc.	FV68S...470	
Coil resistance (Ambient temp. 25°C)	Ω	C-R: 3,07 C-S: 7,97	
Overload relay	External (OLR A)		External (OLR T)
Safety devices	Type	MRA 38066-3229	CS-7C115
	Operating Temp. Open	°C	145 ± 5
	Close	°C	69 ± 11
		Trip in 6 to 16 s at 18 A	//
Run capacitor	μF	22,5	
	VAC	450	

Fan & Fan Motor			
Type	Propeller		
Q'ty Dia.	1.... Ø 370		
Fan motor model...Q'ty	K35410-M01846...1		
No. Of poles...rpm (230 V, High)	4...782		
Nominal output	W	19	
Coil resistance (Ambient temp. 25 °C)	Ω	BLK-WHT: 211±242 WHT-VLT: 244±281 VLT-YEL: 83,5±96,1 BLK-PNK: 41,7±48,0	
Safety devices	Type	Thermal protector	
	Operating temp. Open	°C	150 ± 10
	Close	°C	Automatic
Run capacitor	μF	1,5	
	VAC	450	

Heat Exch. Coil	
Coil	Aluminium plate fin / Copper tube
Rows	1
Fin pitch	mm
Face area	m ²
	1,3
	0,353

External Finish	Acrylic baked-on enamel finish
------------------------	--------------------------------

Outdoor Unit: **AER612SCL**

Controller PCB	
Part No.	POW-CL128E
Control circuit fuse	250 V 3,15 A

Compressor	
Type	Rotary (Hermetic)
Compressor model	802 356 45B C-RN110H5B
Nominal output	W 1100
Compressor oil...Amount	cc. FV68S...520
Coil resistance (Ambient temp. 25°C)	Ω C-R: 1,962 C-S: 5,38
Overload relay	External (OLR A) External (OLR T)
Safety devices	Type MRA 38065-3229 CS-7C115
Operating Temp. Open	°C 145 ± 5 115 ± 3
Close	°C 69 ± 11 95 ± 5
	Trip in 6 to 16 s at 21 A //
Run capacitor	μF 25
	VAC 450

Fan & Fan Motor	
Type	Propeller
Q'ty Dia.	1... Ø 370
Fan motor model...Q'ty	K35410-M01846...1
No. Of poles...rpm (230 V, High)	4...819
Nominal output	W 22
Coil resistance (Ambient temp. 25 °C)	Ω BLK-WHT: 211÷242 WHT-VLT: 244÷281 VLT-YEL: 83,5÷96,1 BLK-PNK: 41,7÷48,0
Safety devices	Type Thermal protector
Operating temp. Open	°C 150 ± 10
Close	°C Automatic
Run capacitor	μF 2
	VAC 450

Heat Exch. Coil	
Coil	Aluminium plate fin / Copper tube
Rows	1
Fin pitch	mm 1,3
Face area	m ² 0,353

External Finish	
	Acrylic baked-on enamel finish

2-3 Other Component Specifications

Outdoor Unit: **AER608SCL**
 AER609SCL
 AER612SCL

Transformer		
Type		ATR-J105
Rating	Primary	230 V ~ 50/60 Hz
	Secondary	19 V 0,526 A
	Capacity	10 VA
Coil resistance (at 21°C)	Ω	Primary (WHT-WHT): 205 ± 10% Secondary (BRN-BRN): 2,0 ± 10%
Thermal cut-off temp.	°C	150

Thermistor		
Type		PBC-41E-S14 or PBC-41E-S4
Resistance	kΩ	-20 °C 40,1 ± 5% 20 °C 6,5 ± 5%
		-10 °C 24,4 ± 5% 30 °C 4,4 ± 5%
		0 °C 15,3 ± 5% 40 °C 3,0 ± 5%
		10 °C 9,9 ± 5% 50 °C 2,1 ± 5%

3. DIMENSIONAL DATA

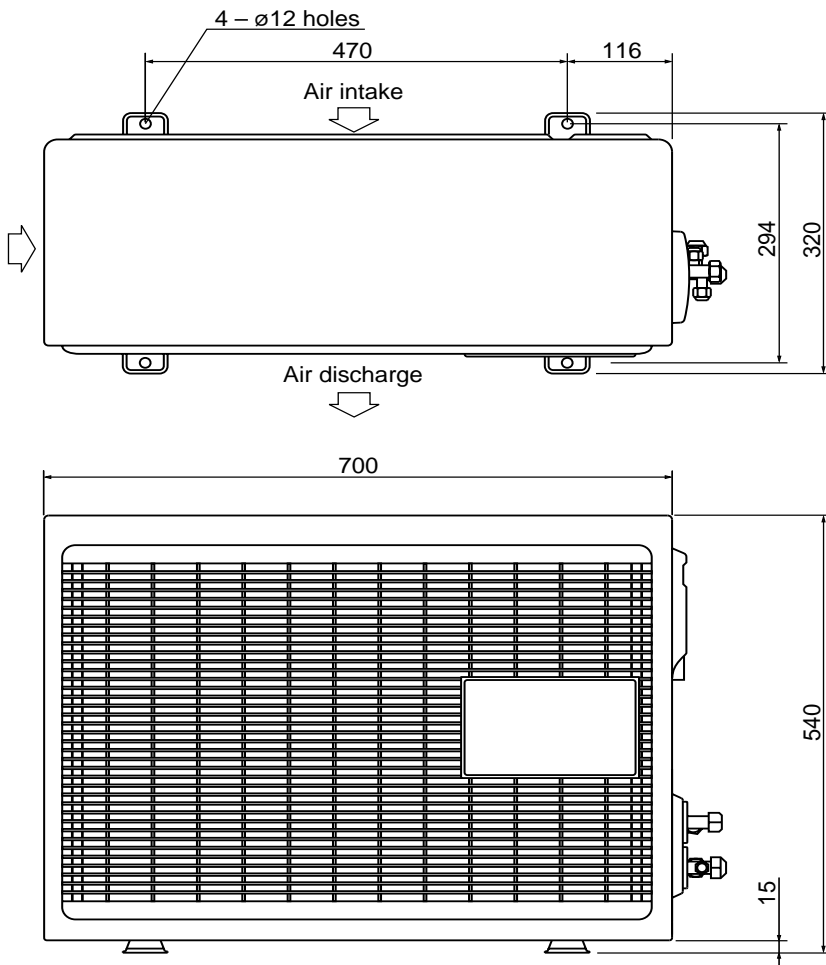

Wide tube service valve
 $\varnothing 9.52$ (3/8") 7000/9000 BTU/h
 $\varnothing 12.7$ (1/2") 12000 BTU/h

Narrow tube service valve
 $\varnothing 6.35$ (1/4")

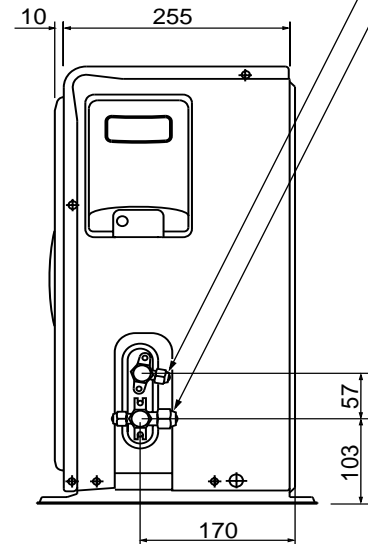

Unit : mm

4. REFRIGERANT FLOW DIAGRAM

Indoor Unit: Outdoor Unit: **AER608SCL**
AER609SCL

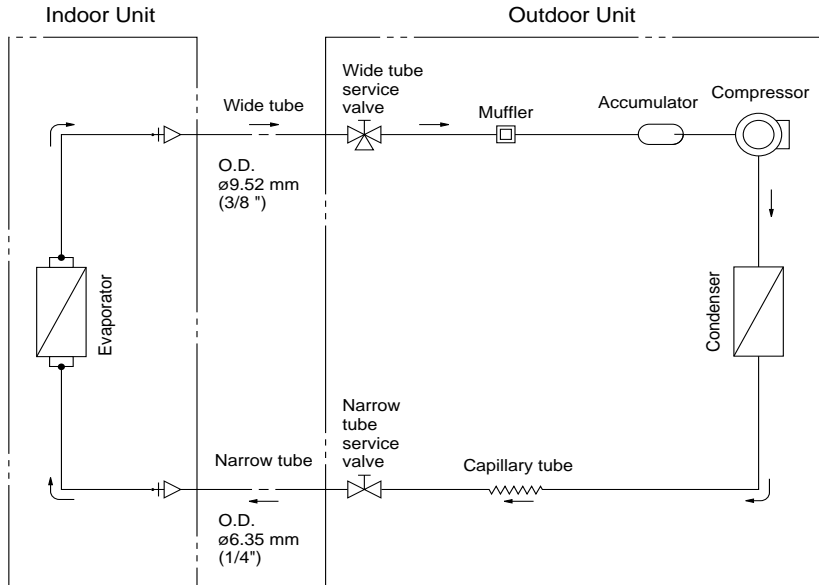

Indoor Unit: Outdoor Unit: **AER612SCL**

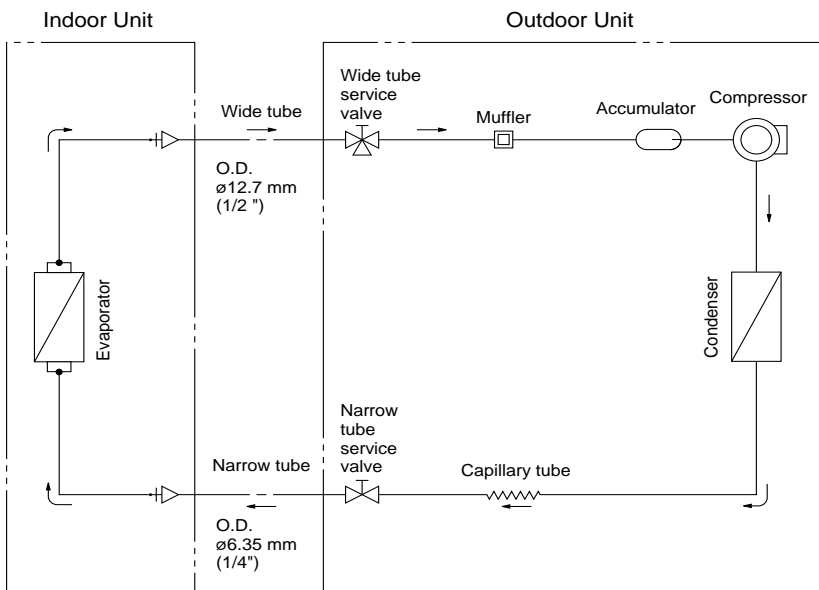

Insulation of Refrigerant Tubing

IMPORTANT

Because capillary tubing is used in the outdoor unit, both the wide and narrow tubes of this air conditioner become cold. To prevent heat loss and wet floors due to dripping of condensation, **both tubes must be well insulated** with a proper insulation material. The thickness of the insulation should be a min. 8 mm.

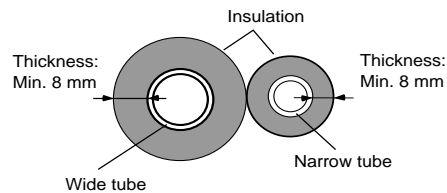

CAUTION

After a tube has been insulated, never try to bend it into a narrow curve because it can cause the tube to break or crack.

5. PERFORMANCE DATA

5-1 Performance charts

AER608SCL

■ Cooling Characteristics

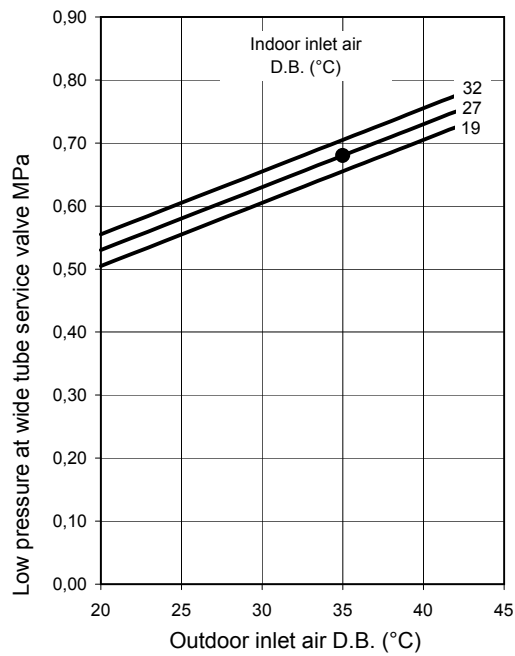
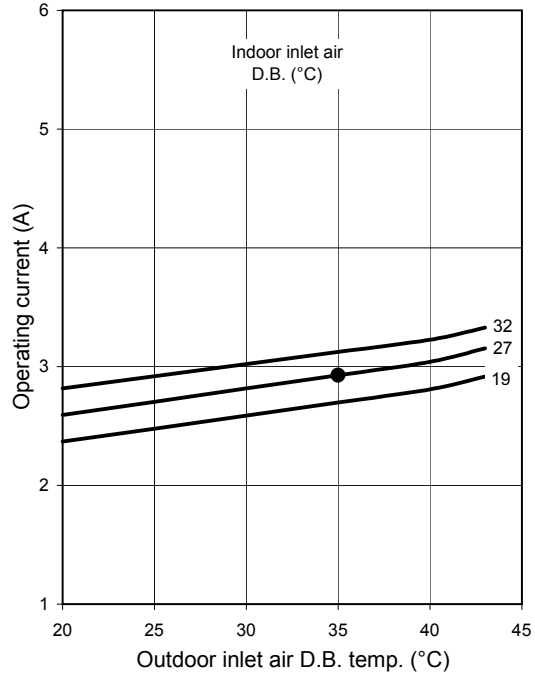

Notes:

- Points of Rating condition

Data referred to indoor unit AWR608CL

AER609SCL

■ Cooling Characteristics

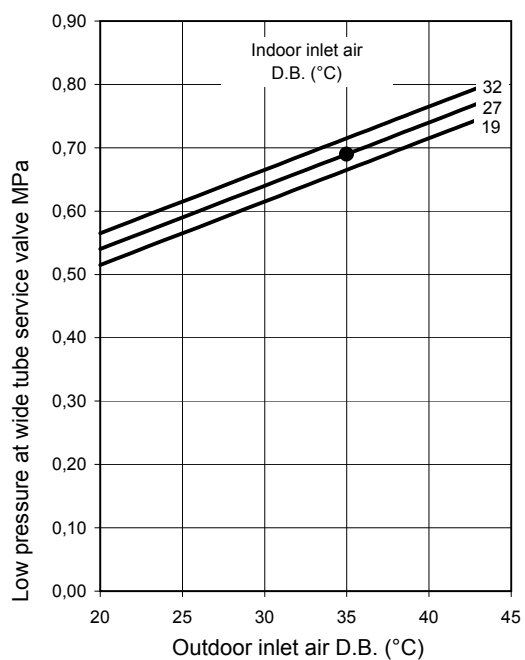
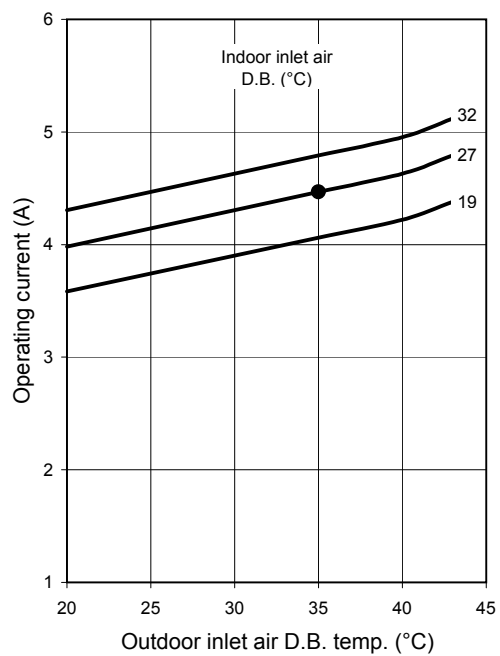

Notes:

- Points of Rating condition

Data referred to indoor unit AWR609CL

AER612SCL

■ Cooling Characteristics

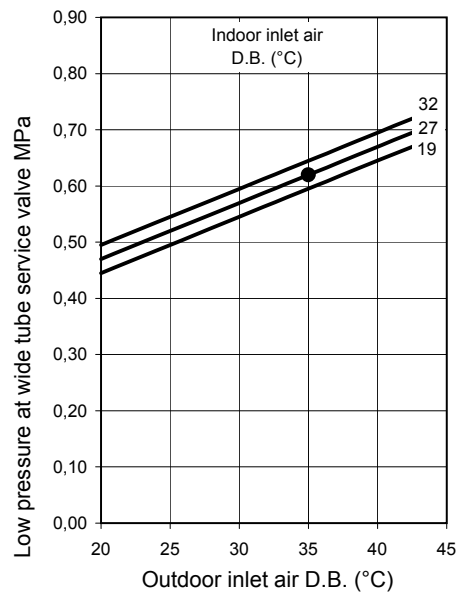
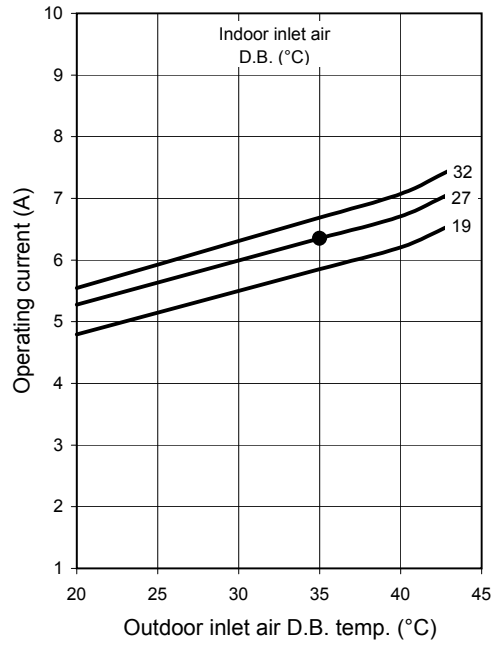

Notes:

- Points of Rating condition

Data referred to indoor unit AWR612CL

5-2 Cooling Capacity

OUTDOOR UNIT: **AER608SCL**

220 - 240 V ~ 50 Hz

RATING CAPACITY		1,90 kW	moisture removal		0,4 l/h			
COMP. POWER INPUT		0,586 kW	max comp input		0,666 kW			
AIR FLOW RATE		430 m³/h						
EVAPORATOR			CONDENSER					
ENT.TEMP. °C			OUTDOOR AMBIENT TEMP. °C					
W.B.	D.B.		20	25	30	35	40	43
15		TC	1,92	1,80	1,75	1,66	1,56	1,44
		CM	0,48	0,51	0,53	0,55	0,57	0,60
	21	SHC	1,33	1,23	1,21	1,17	1,12	1,06
	23	SHC	1,51	1,40	1,37	1,33	1,28	1,22
	25	SHC	1,67	1,56	1,53	1,49	1,44	1,38
	27	SHC	1,84	1,72	1,69	1,65	1,56	1,44
	29	SHC	1,92	1,80	1,75	1,66	1,56	1,44
	31	SHC	1,92	1,80	1,75	1,66	1,56	1,44
17		TC	2,06	1,95	1,88	1,78	1,68	1,54
		CM	0,50	0,52	0,55	0,57	0,59	0,61
	21	SHC	1,15	1,08	1,05	1,01	0,96	0,90
	23	SHC	1,32	1,24	1,21	1,16	1,12	1,06
	25	SHC	1,49	1,41	1,37	1,33	1,28	1,21
	27	SHC	1,67	1,57	1,52	1,48	1,43	1,38
	29	SHC	1,84	1,73	1,69	1,64	1,59	1,53
	31	SHC	2,01	1,90	1,84	1,78	1,68	1,54
19		TC	2,19	2,07	2,00	1,90	1,78	1,64
		CM	0,52	0,54	0,56	0,59	0,61	0,63
	21	SHC	0,96	0,90	0,88	0,83	0,78	0,73
	23	SHC	1,14	1,06	1,04	1,00	0,95	0,89
	25	SHC	1,31	1,22	1,19	1,15	1,11	1,05
	27	SHC	1,48	1,38	1,35	1,62	1,26	1,21
	29	SHC	1,65	1,53	1,51	1,47	1,43	1,36
	31	SHC	1,82	1,69	1,67	1,63	1,58	1,52
21		TC	2,30	2,19	2,11	2,02	1,89	1,74
		CM	0,54	0,56	0,58	0,61	0,63	0,65
	23	SHC	0,94	0,89	0,86	0,82	0,77	0,71
	25	SHC	1,12	1,05	1,02	0,98	0,93	0,88
	27	SHC	1,29	1,20	1,18	1,14	1,09	1,03
	29	SHC	1,46	1,36	1,34	1,30	1,25	1,19
	31	SHC	1,63	1,52	1,50	1,46	1,41	1,35
	23		TC	2,45	2,31	2,24	2,11	1,98
CM			0,56	0,58	0,60	0,62	0,65	0,67
25		SHC	0,92	0,87	0,84	0,79	0,74	0,69
27		SHC	1,09	1,02	1,00	0,95	0,90	0,85
29		SHC	1,27	1,17	1,16	1,11	1,06	1,01
31		SHC	1,44	1,33	1,32	1,27	1,22	1,17

TC: TOTAL COOLING CAPACITY kW
 SHC: SENSIBLE HEAT CAPACITY kW
 CM: COMPRESSOR INPUT kW

RATING CONDITIONS

Cooling: Indoor air temperature 27°C D.B. / 19°C W.B.

Outdoor air temperature 35°C D.B. / 24°C W.B.

NOTE: Data referred to indoor unit AWR608CL

OUTDOOR UNIT: **AER609SCL**

220 - 240 V ~ 50 Hz

RATING CAPACITY		2,60 kW	moisture removal		0,8 l/h			
COMP. POWER INPUT		0,89 kW	max comp input		1,02 kW			
AIR FLOW RATE		450 m ³ /h						
EVAPORATOR		CONDENSER						
ENT.TEMP. °C		OUTDOOR AMBIENT TEMP. °C						
W.B.	D.B.		20	25	30	35	40	43
15		TC	2,63	2,46	2,39	2,28	2,14	1,97
		CM	0,73	0,76	0,80	0,83	0,86	0,89
	21	SHC	1,82	1,69	1,66	1,60	1,53	1,45
	23	SHC	2,06	1,91	1,88	1,82	1,75	1,67
	25	SHC	2,29	2,13	2,09	2,03	1,97	1,89
	27	SHC	2,52	2,36	2,31	2,26	2,14	1,97
	29	SHC	2,63	2,46	2,39	2,28	2,14	1,97
17		TC	2,81	2,67	2,57	2,44	2,29	2,11
		CM	0,76	0,80	0,83	0,86	0,89	0,93
	21	SHC	1,57	1,48	1,44	1,38	1,31	1,23
	23	SHC	1,81	1,70	1,65	1,59	1,53	1,45
	25	SHC	2,04	1,93	1,87	1,81	1,75	1,66
	27	SHC	2,28	2,15	2,09	2,03	1,96	1,88
	29	SHC	2,52	2,37	2,31	2,25	2,18	2,10
19		TC	2,99	2,83	2,73	2,60	2,44	2,25
		CM	0,80	0,83	0,86	0,89	0,93	0,96
	21	SHC	1,32	1,24	1,20	1,14	1,07	0,99
	23	SHC	1,56	1,46	1,42	1,36	1,29	1,22
	25	SHC	1,79	1,67	1,63	1,58	1,51	1,43
	27	SHC	2,02	1,88	1,85	2,04	1,73	1,65
	29	SHC	2,26	2,09	2,07	2,01	1,95	1,87
21		TC	3,15	3,00	2,89	2,76	2,59	2,39
		CM	0,83	0,86	0,89	0,93	0,96	0,99
	23	SHC	1,29	1,22	1,18	1,12	1,06	0,98
	25	SHC	1,53	1,43	1,40	1,35	1,28	1,20
	27	SHC	1,76	1,65	1,62	1,56	1,50	1,41
	29	SHC	2,00	1,86	1,83	1,78	1,71	1,63
	31	SHC	2,22	2,08	2,05	2,00	1,93	1,85
23		TC	3,35	3,16	3,06	2,89	2,71	2,52
		CM	0,86	0,89	0,93	0,96	0,99	1,02
	25	SHC	1,26	1,19	1,15	1,09	1,02	0,95
	27	SHC	1,50	1,39	1,36	1,30	1,23	1,16
	29	SHC	1,73	1,60	1,58	1,52	1,45	1,38
	31	SHC	1,97	1,83	1,80	1,74	1,67	1,61

TC: TOTAL COOLING CAPACITY kW
 SHC: SENSIBLE HEAT CAPACITY kW
 CM: COMPRESSOR INPUT kW

RATING CONDITIONS

Cooling: Indoor air temperature 27°C D.B. / 19°C W.B.

Outdoor air temperature 35°C D.B. / 24°C W.B.

NOTE: Data referred to indoor unit AWR609CL

OUTDOOR UNIT: **AER612SCL**

220 - 240 V ~ 50 Hz

RATING CAPACITY		3,40 kW	moisture removal	1,5 l/h				
COMP. POWER INPUT		1,271 kW	max comp input	1,491 kW				
AIR FLOW RATE		470 m³/h						
EVAPORATOR		CONDENSER						
ENT.TEMP. °C		OUTDOOR AMBIENT TEMP. °C						
W.B.	D.B.		20	25	30	35	40	43
15		TC	3,43	3,22	3,13	2,98	2,79	2,58
		CM	0,98	1,05	1,12	1,19	1,27	1,34
	21	SHC	2,38	2,21	2,17	2,09	2,00	1,90
	23	SHC	2,69	2,50	2,45	2,38	2,29	2,19
	25	SHC	2,99	2,79	2,73	2,66	2,57	2,47
	27	SHC	3,30	3,08	3,02	2,95	2,79	2,58
	29	SHC	3,43	3,22	3,13	2,98	2,79	2,58
17		TC	3,68	3,49	3,36	3,19	3,00	2,76
		CM	1,02	1,09	1,16	1,23	1,30	1,38
	21	SHC	2,05	1,93	1,88	1,80	1,71	1,60
	23	SHC	2,36	2,22	2,16	2,08	2,00	1,89
	25	SHC	2,67	2,52	2,45	2,37	2,28	2,17
	27	SHC	2,98	2,81	2,73	2,65	2,56	2,46
	29	SHC	3,29	3,10	3,02	2,94	2,85	2,74
19		TC	3,91	3,70	3,57	3,40	3,19	2,94
		CM	1,06	1,13	1,20	1,27	1,34	1,41
	21	SHC	1,73	1,62	1,57	1,49	1,40	1,30
	23	SHC	2,04	1,90	1,86	1,78	1,69	1,59
	25	SHC	2,35	2,18	2,14	2,06	1,98	1,87
	27	SHC	2,64	2,46	2,42	2,35	2,26	2,16
	29	SHC	2,95	2,73	2,71	2,63	2,55	2,44
21		TC	4,11	3,92	3,78	3,61	3,39	3,12
		CM	1,08	1,16	1,23	1,30	1,38	1,45
	23	SHC	1,69	1,60	1,54	1,47	1,38	1,28
	25	SHC	2,00	1,87	1,83	1,76	1,67	1,57
	27	SHC	2,31	2,15	2,11	2,04	1,96	1,85
	29	SHC	2,62	2,43	2,39	2,33	2,24	2,14
	31	SHC	2,91	2,71	2,68	2,61	2,53	2,42
23		TC	4,39	4,14	4,01	3,78	3,54	3,30
		CM	1,11	1,19	1,26	1,34	1,41	1,49
	25	SHC	1,65	1,55	1,50	1,42	1,33	1,24
	27	SHC	1,96	1,82	1,78	1,70	1,61	1,52
	29	SHC	2,27	2,09	2,07	1,99	1,90	1,81
	31	SHC	2,58	2,39	2,36	2,27	2,18	2,10

TC: TOTAL COOLING CAPACITY kW
 SHC: SENSIBLE HEAT CAPACITY kW
 CM: COMPRESSOR INPUT kW

RATING CONDITIONS

Cooling: Indoor air temperature 27°C D.B. / 19°C W.B.

Outdoor air temperature 35°C D.B. / 24°C W.B.

NOTE: Data referred to indoor unit AWR612CL

6. ELECTRICAL DATA

6-1 Electrical characteristics

OUTDOOR UNIT: **AER608SCL**

			Indoor Unit	Outdoor unit		Complete Unit
			Fan Motor	Fan Motor	Compressor	
Performance at			230 V 1-Phase 50 Hz			
Rating conditions	Running Amps.	A	0,110	0,316	2,774	3,200
	Power input	kW	0,025	0,069	0,586	0,680
Full load conditions	Running Amps.	A	0,110	0,316	3,074	3,500
	Power input	kW	0,025	0,069	0,666	0,760

NOTE: Data referred to indoor unit AWR608CL
For other indoor unit models there could be some differences.

OUTDOOR UNIT: **AER609SCL**

			Indoor Unit	Outdoor unit		Complete Unit
			Fan Motor	Fan Motor	Compressor	
Performance at			230 V 1-Phase 50 Hz			
Rating conditions	Running Amps.	A	0,120	0,316	3,964	4,400
	Power input	kW	0,027	0,069	0,894	0,990
Full load conditions	Running Amps.	A	0,120	0,316	4,464	4,900
	Power input	kW	0,027	0,069	1,024	1,120

NOTE: Data referred to indoor unit AWR609CL
For other indoor unit models there could be some differences.

OUTDOOR UNIT: **AER612SCL**

			Indoor Unit	Outdoor unit		Complete Unit
			Fan Motor	Fan Motor	Compressor	
Performance at			230 V 1-Phase 50 Hz			
Rating conditions	Running Amps.	A	0,130	0,357	5,813	6,300
	Power input	kW	0,031	0,078	1,271	1,380
Full load conditions	Running Amps.	A	0,130	0,357	7,013	7,500
	Power input	kW	0,031	0,078	1,491	1,600

NOTE: Data referred to indoor unit AWR612CL
For other indoor unit models there could be some differences.

Rating Conditions: Indoor Air Temperature 27°C D.B. / 19°C W.B.
Outdoor Air Temperature 35°C D.B.
Full Load Conditions: Indoor Air Temperature 32°C D.B. / 23°C W.B.
Outdoor Air Temperature 43°C D.B.

6-2 Electric Wiring Diagram

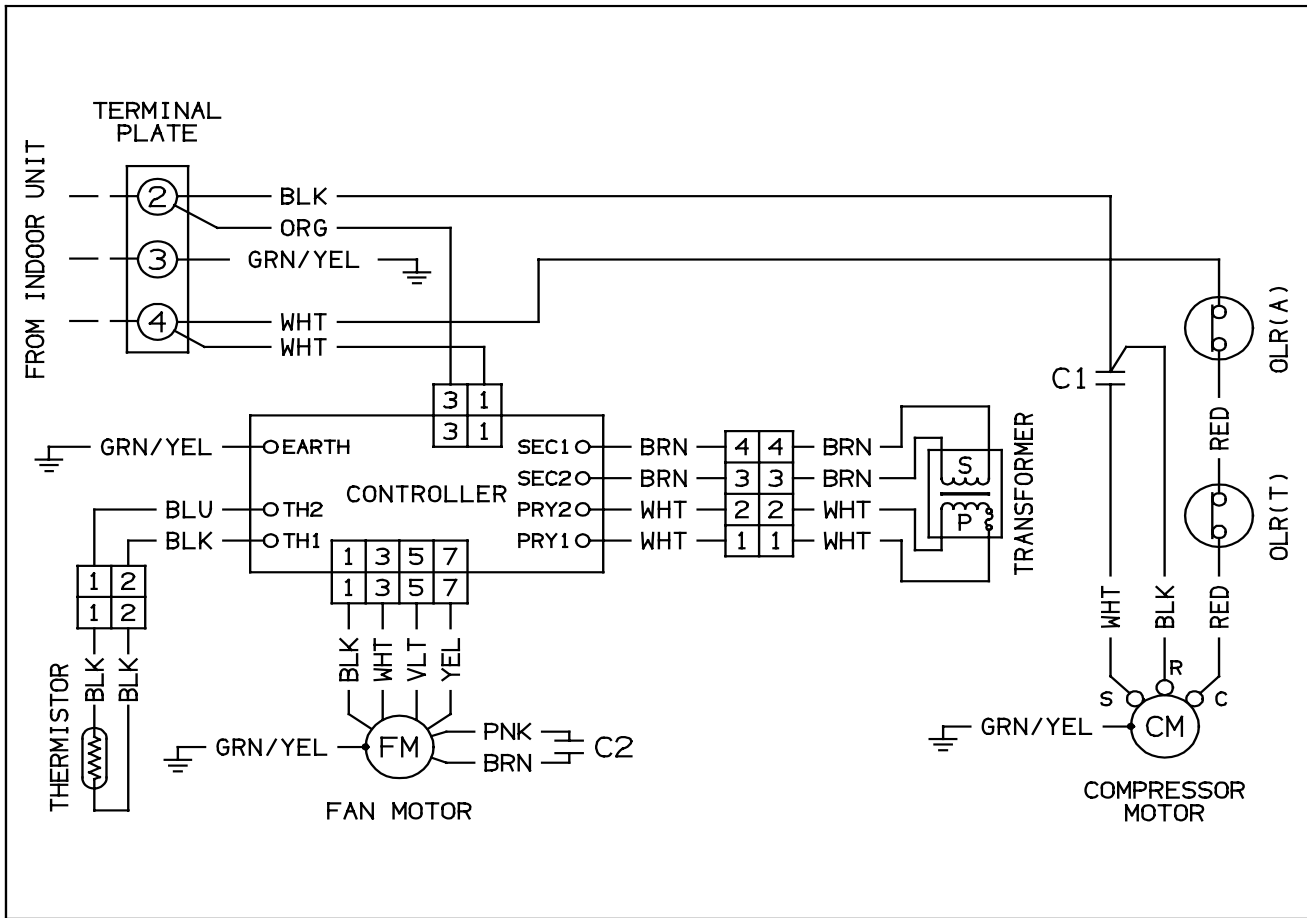

6-3 System Wiring Diagram

INDOOR UNIT

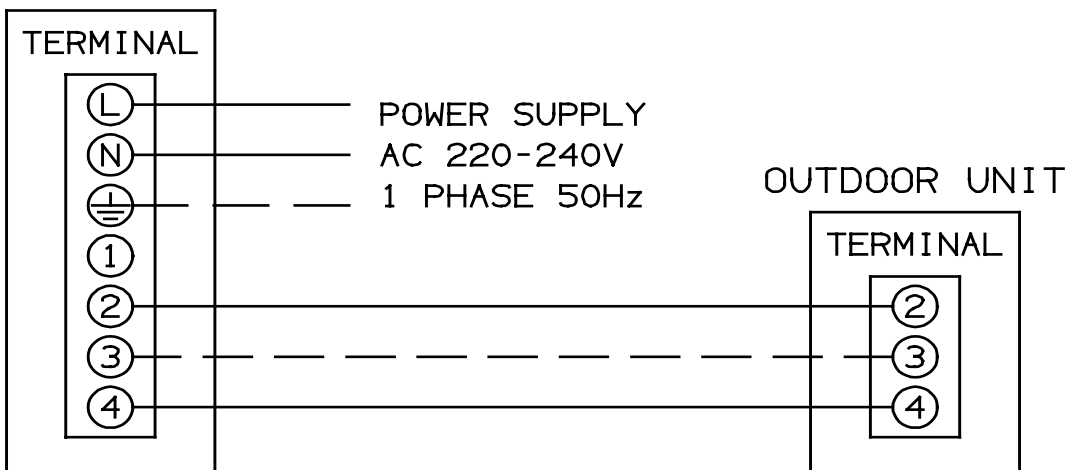

argoclima s.p.a.

Via Varese, 90 - 21013 Gallarate - Va - Italy
Tel. +39 0331 755111 - Fax +39 0331 776240
www.argoclima.it