

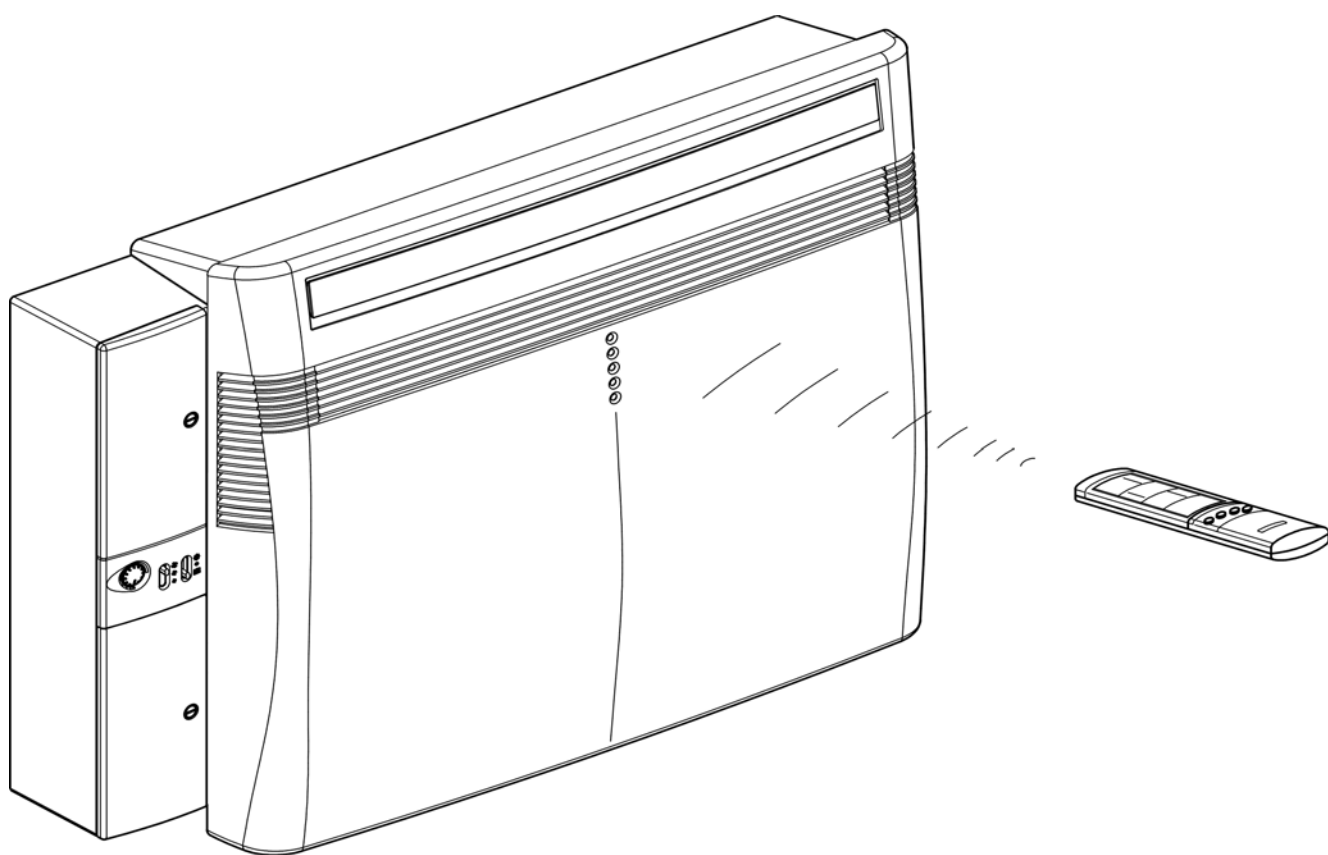

TECHNICAL DATA & SERVICE MANUAL



ARGO 245C / 3SC Cooling only model

ARGO 235H / 3HP Heat pump model

Table of contents

	Page
A SPECIFICATIONS	
1) Unit specifications	3
2) Major Component specifications	4
B OPERATING RANGE	5
C DIMENSIONAL DATA	6
D PERFORMANCE CHARTS	7
E REFRIGERANT FLOW DIAGRAMS	10
F FUNCTIONS	
1) Cool Mode Operation	11
2) Heat Mode Operation	12
3) Auto (Cool/Heat) Mode Operation	13
4) Dry Mode Operation	14
5) Fan Mode Operation	15
6) Protection Operations in Cool and Dry Modes	15
7) Protection Operations in Heat Mode	17
8) Sleep Function	20
9) Daily Timer Function	20
10) IFEEL Function	20
11) Manual Unit control and Led indicators	21
12) Recovery from power failure	21
13) Outdoor fan operation	22
G ELECTRIC WIRING DIAGRAMS	23/24
H TROUBLESHOOTING	25
I REFRIGERANT CHARGE	32
L CHECKING ELECTRICAL COMPONENTS	
1) Measurement of Insulation Resistance	33
2) Checking Continuity of Fuse on PCS Ass'y	34
3) Checking Motor Capacitor	34
M BOILER CONNECTION KIT	
1) Specifications and operating limits	35
2) Performance charts	36
3) Component specifications	37
4) Hydraulic connections and valves	38

A SPECIFICATIONS

1) UNIT SPECIFICATIONS

UNIT MODEL		ARGO 245C / 3SC	ARGO 235H / 3HP	
Power source		220 - 240 V 50 Hz		
PERFORMANCES		COOLING	COOLING	HEATING
Capacity (air conditioner)	BTU / h	8360	8020	7700
	kW	2,45	2,35	2,25
Capacity (hot-water system)	BTU / h	7160		
	kW	2,1		
Air circulation (high/med/low)		m ³ / h		330-300-280
Moisture removal (high speed)		l / h	1,2	1,0
Dry 27°C (60% R.U.)		liters / 24h	30	30
30°C (80% R.U.)		liters / 24h	59	59
ELECTRICAL RATINGS				
Voltage rating		V	220 - 240	
Available voltage range		V	198 - 264	
Running Ampere (air conditioner)		A	4,3	4,2
Running Ampere (hot-water system)		A	0,10	
Power input (air conditioner)		W	935	900
Power input (hot-water system)		W	27	
Power factor			0,95	0,93
C.O.P			2,62	2,61
Compressor locked rotor amperes		A	17	
FEATURES				
Controls / temperature control		Microprocessor / I.C. Thermostat		
Control unit		Wireless remote control unit		
Timer		ON / OFF 24 hours and program		
Fan speed (air conditioner)		3 + Auto		
Fan speed (hot-water system)		3		
Airflow direction (Indoor)	Horizontal	Auto (manual for hot water system)		
	Vertical	Manual		
Air filter		Washable, easy access		
Compressor		Rotary (hermetic)		
Refrig./Stand. Charge at shipmen		R410A	600g	520g
Refrigerant control		Capillary tube		
Sound pressure level (Indoor)	Air conditioner Hi/Me/Lo dB(A)	45-43-41		
	Hot-water system Hi/Me/Lo dB(A)	42-39-32		
Sound pressure level (outdoor)	Air conditioner Hi dB(A)	53 to 4 m.		
	Air conditioner Lo dB(A)	48,5 to 4 m.		
Ducts diameter (2pcs)		mm	162	
Water connections diameter onli models 245C / 235H		1/2" Gas		
Condensate drain system		Not requested	By duct	
DIMENSIONS AND WEIGHT				
Height		mm	735	
Widht		mm	839	
Depht		mm	260-280	
Holes diameter in the wall (2)		mm	162	
Net weight		kg	50 / 48,75	52 / 50,75

Data can be changed without notice

NOTE

Rating conditions:

Cooling: outside air temp.: 35° C DB, indoor air temp.: 27° C DB, 19° C WB

Heating: outside air temp.: 7° C DB, 6° C WB, indoor air temp.: 20° C DB

2) MAJOR COMPONENT SPECIFICATIONS

UNIT MODEL		ARGO 245C / 3SC	ARGO 235H / 3HP
CONTROLLER (PCB)			
Part No.		KSA - CTRL - DB	
Controls		Microprocessor	
Control circuit fuse (F1)		250VAC - 5A -T	
Jumper Setting J1...J8 (see Electric wiring diagram)		2,54mm - 6 pcs	2,54mm - 5 pcs
SWITCH INDICATOR ASSY			
PCB			
Model		384208021	
Led color		TMR : blu - STB : yellow - OPR : green	
REMOTE CONTROL UNIT			
		RC-7 (ST)	RC-7 (RC)
THERMISTOR (COIL SENSOR) TH1			
NTC (with brass pipe)			
Resistance (at 25° C)	kΩ	10 ± 3%	
THERMISTOR (ROOM SENSOR) TH2			
Resistance (at 25° C)	kΩ	10 ± 5%	
THERMISTOR (COIL SENSOR) TH3			
NTC (with brass pipe)			
Resistance (at 25° C)	kΩ	---	10 ± 1%
THERMISTOR (OUTDOOR AIR SENSOR) TH5			
Resistance (at 25° C)	kΩ	10 ± 5%	
RESISTOR OUT P7			
Resistance (at 25° C)	kΩ	4,7 ± 5%	---
Nominal power	W	0,5 ± 5%	---
FAN & FAN MOTOR (FMI)			
Model		K35406-MO2024	
Number / Diameter / Length		mm Cross-flow 1 / Ø100 / 515	
No. of pole / rpm (230 V, high)		4 / 1350	
Nominal input		W 30	
Coil resistance (at 25° C)		Ω GRY-WHT: 545±630 WHT-VLT: 92±105 VLT-ORG: 62±71 GRY-BRN: 78±90	
Safety device		(Internal bimetallic type)	
Setting	Open	°C	150 ± 10K
	Close		Autoreset
Run capacitor (C2)		μF	1,5
		VAC	440
FAN & FAN MOTOR (FMO)			
Model		D2E 146 - HS03 - 46	
Number / Diameter / Length		mm Centrifugal 1 / Ø146 / 140	
No. of pole / rpm (230 V)		2 / 2060	
Nominal input		W 180	
Coil resistance (at 25° C)		Ω BLU-BRN: 74± 5% BLU-BLK: 66± 5%	
Safety device		(Internal bimetallic type)	
Setting	Open	°C	150 ± 5K
	Close		Autoreset
Run capacitor (C3)		μF	5
		VAC	420
COMPRESSOR (CM)			
Rotary (Hermetic)			
Model		5PS102EAA	
Nominal cooling capacity		W 2350	
Compressor oil RB68A or Freol Alpha68M		cc 350	
Coil resistance (at 20° C)		Ω	C-R : 3.863
		Ω	C-S : 3.309
Run capacitor (C1)		μF	30
		VAC	450
Overload relay (OLR)			
External			
Operating temperature	Open	°C	148 ± 5°C
	Close	°C	69 ± 9°C
Operating amp. (Ambient temp. 25° C)		Trip in 6 to 16 sec. at 16A	

UNIT MODEL		ARGO 245C / 3SC	ARGO 235H / 3HP
CONDENSATE PUMP (PC)			
Model		291036	
Rating		220-240VAC~50Hz	
Nominal input		5W - 0,05A	
Coil resistance (at 20° C)	Ω	778 ± 8%	
SAFETY FLOAT SWITCH (FS)			
Model		BI 1300 2725	
Contact rating		230 V AC/DC - 0,5 A	
FLAP MOTOR (FLP)			
Type		Stepping motor	
Model		MP24GA1	
Rating		DC 12V	
Coil resistance (Ambient temp. 25°C)	Ω	WHT-BLU (respectively 4 wires) : 380 ± 7%	
4 WAYS VALVE (20S)			
Model		---	SQ-136
Coil rating		---	AC 220V, 50 Hz, 6W
Coil resistance (Ambient temp. 20°C)	Ω	---	1440 ± 5%
HEAT EXCHANGER COIL (EVAPORATOR)			
Coil		Aluminium plate fin / copper tube	
Rows		3	
Fin pitch	mm	1,6	
Face area	m ²	0,107	
HEAT EXCHANGER COIL (CONDENSER)			
Coil		Aluminium plate fin / copper tube	
Rows		4	
Fin pitch	mm	1,3	
Face area	m ²	0,111	
THERMOSTATIC VALVE DRAIN PAN			
Model		---	DP 25-1101-07 or DP 25-1107
Open	°C	---	4,4
Close	°C	---	15,5
Stroke	mm	---	5,16

B OPERATING RANGE

Cooling only model

	Temperature	Indoor air intake temp.	Outdoor air intake temp.
Cooling	Maximum	32° C DB/ 23° C WB	43° C DB
	Minimum	19° C DB/ 14° C WB	19° C DB
Dry	Maximum	32° C BS/ 80% R.U.	43° C DB
	Minimum	16° C BS/ 80% R.U.	16° C DB

Heat pump model

	Temperature	Indoor air intake temp.	Outdoor air intake temp.
Cooling	Maximum	32° C DB/ 23° C WB	43° C DB
	Minimum	19° C DB/ 14° C WB	19° C DB
Heating	Maximum	27° C DB	24° C DB / 18° C WB
	Minimum	//	-8° C DB / -9° C WB
Dry	Maximum	32° C BS/ 80% R.U.	43° C DB
	Minimum	16° C BS/ 80% R.U.	16° C DB

C

DIMENSIONAL DATA

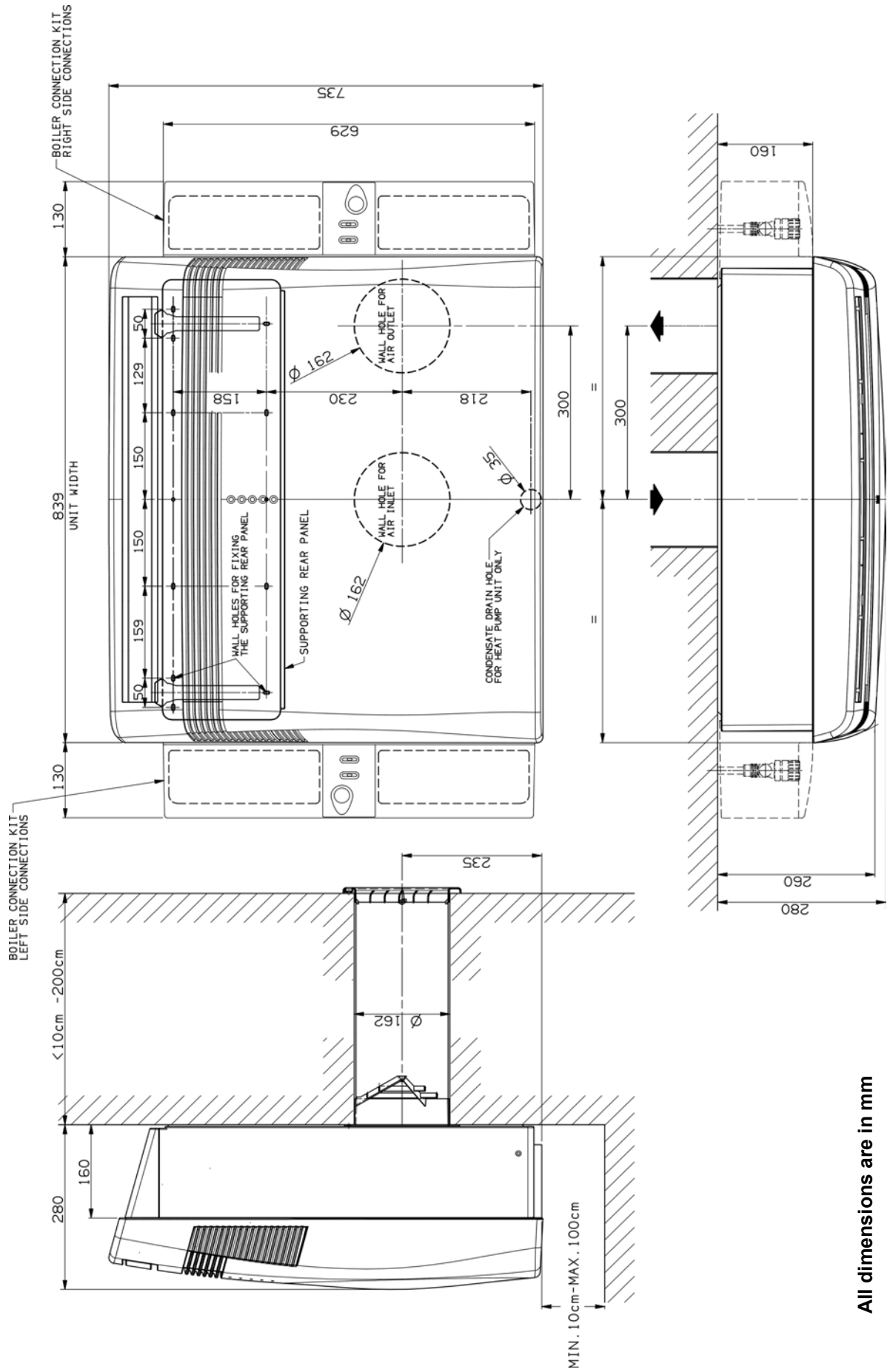

All dimensions are in mm

D**PERFORMANCE CHARTS****ARGO 245C / 3SC Cooling only model**

Conditions: Power source
Indoor air velocity

230 V - 1- 50 Hz - Single phase
High speed

Cooling characteristics
Indoor relative humidity 48%

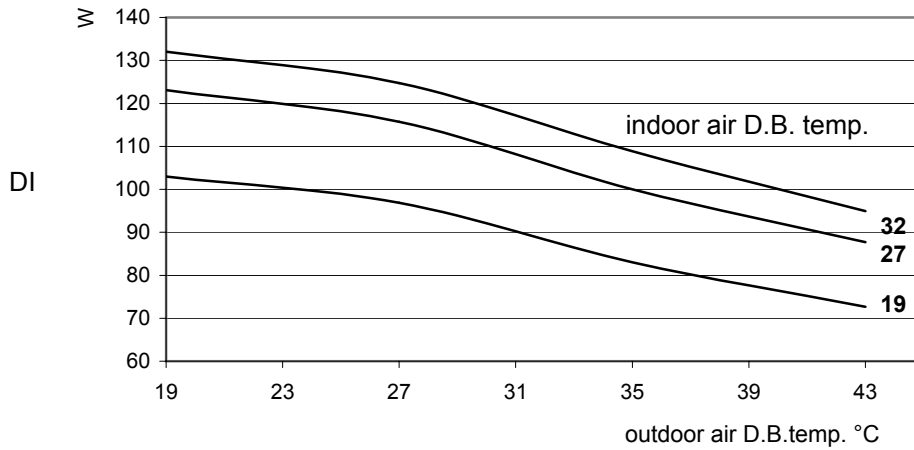
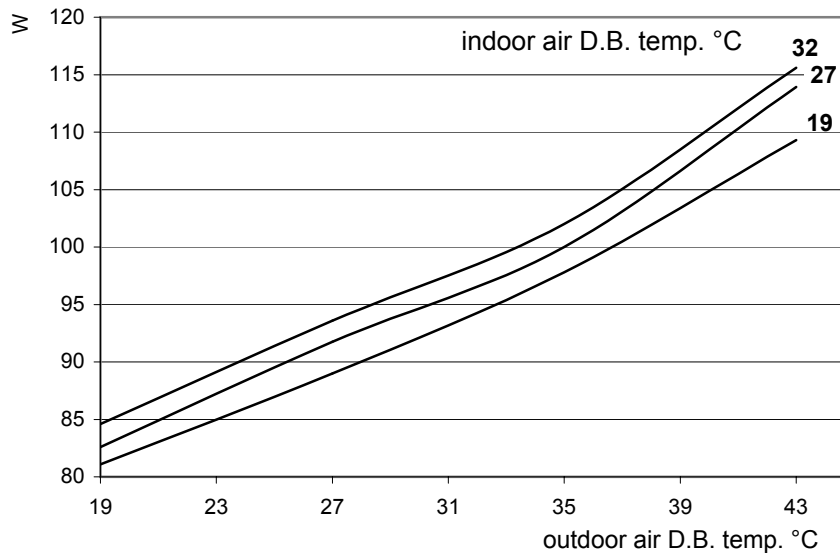
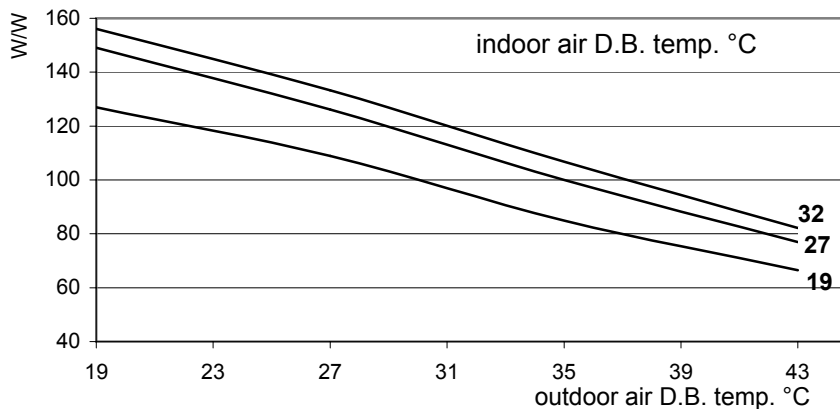
Capacity (%)**Power input (%)****E.E.R. (%)**

ARGO 235H / 3HP Heat pump model

Conditions: Power source
Indoor air velocity

230 V - 1- 50 Hz - Single phase
High speed

Cooling characteristics
Indoor relative humidity 48%

Capacity (%)

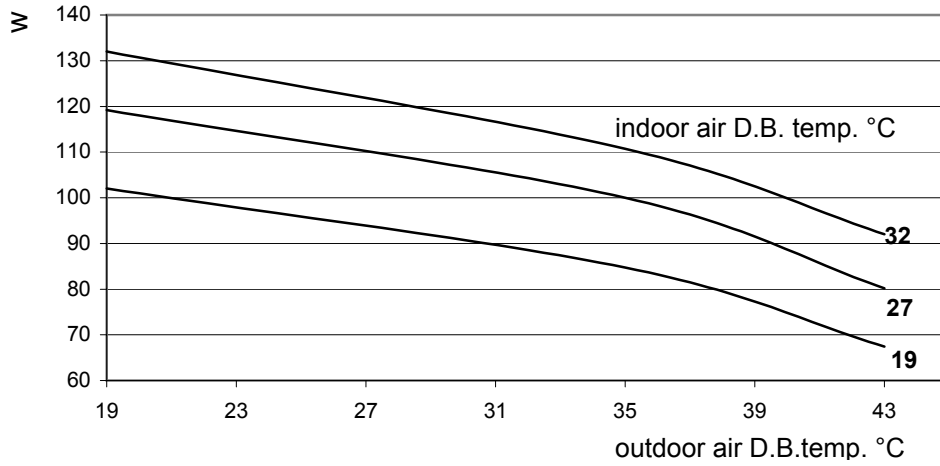

Power input (%)

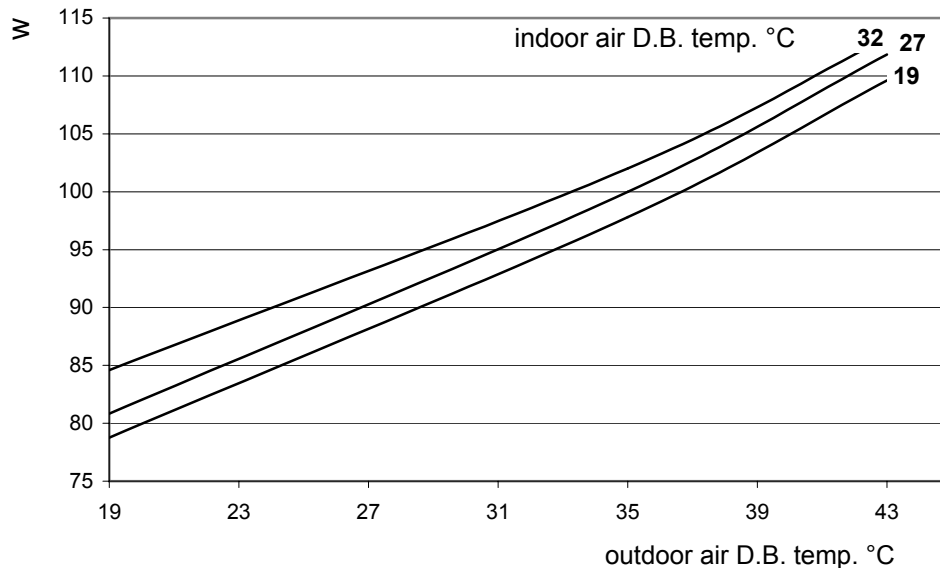

E.E.R. (%)

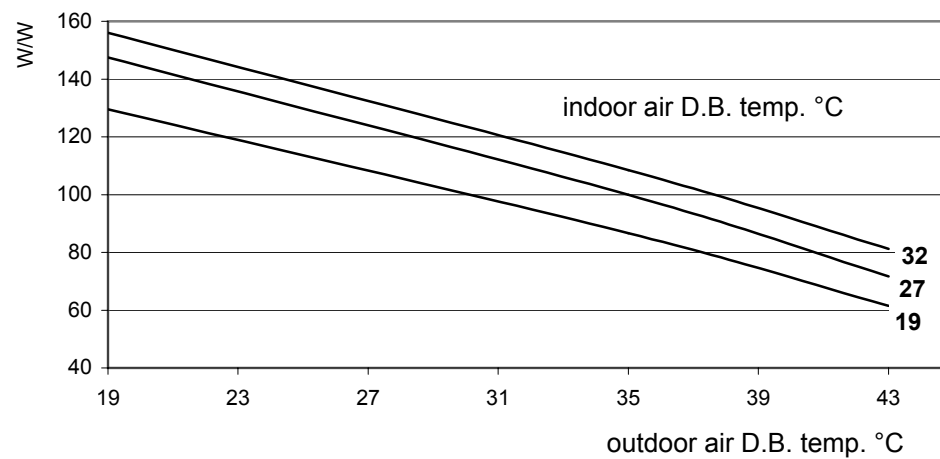

Heating characteristics

Outdoor relative humidity 85%

Capacity (%)

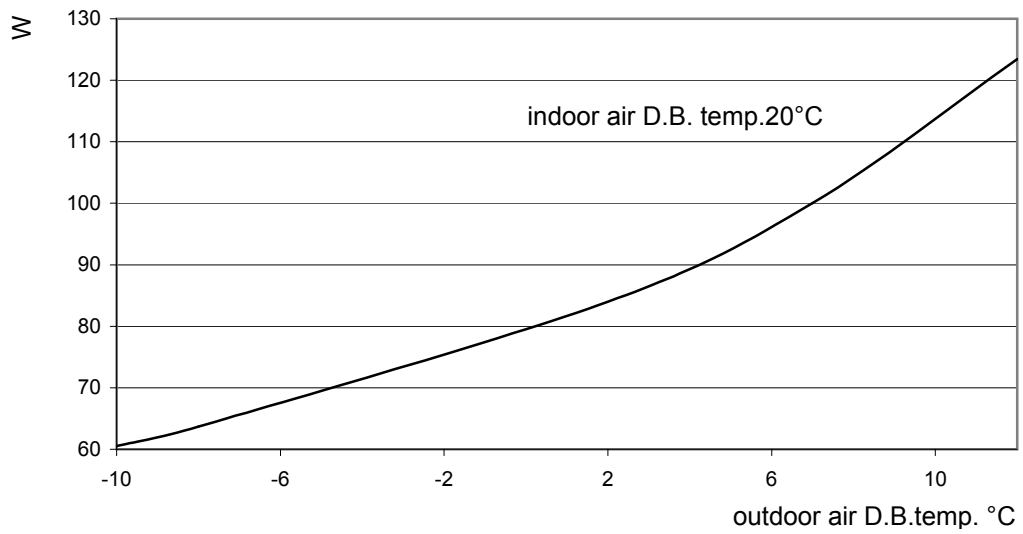

Power input (%)

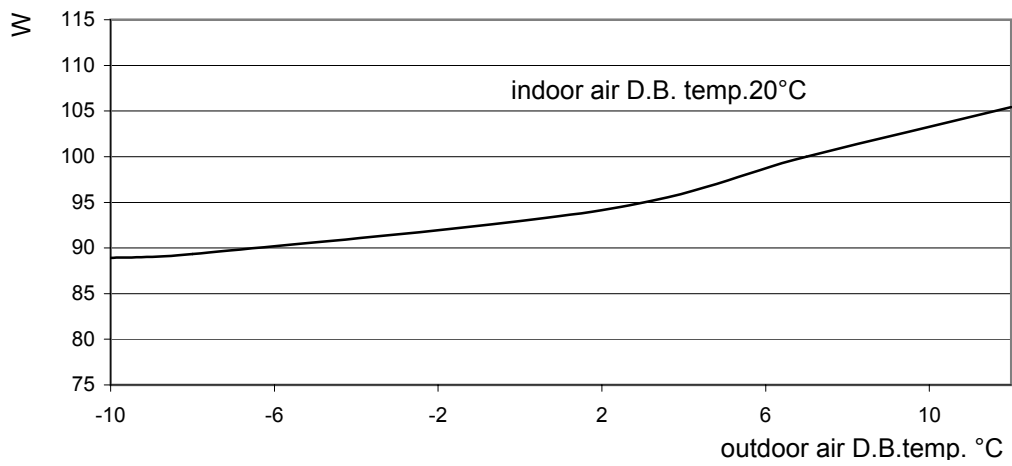

COP (%)



E REFRIGERANT FLOW DIAGRAM COOLING MODEL

ARGO 245C / 3SC

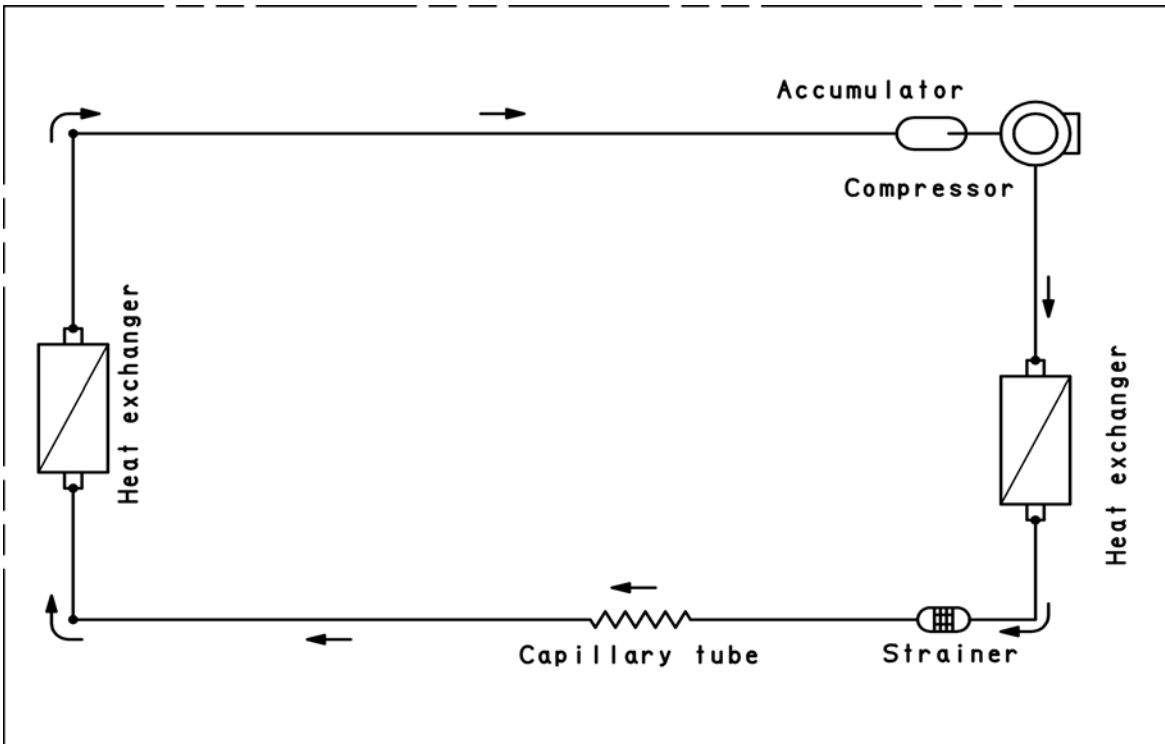

REFRIGERANT FLOW DIAGRAM HEAT PUMP MODEL

ARGO 235H / 3HP

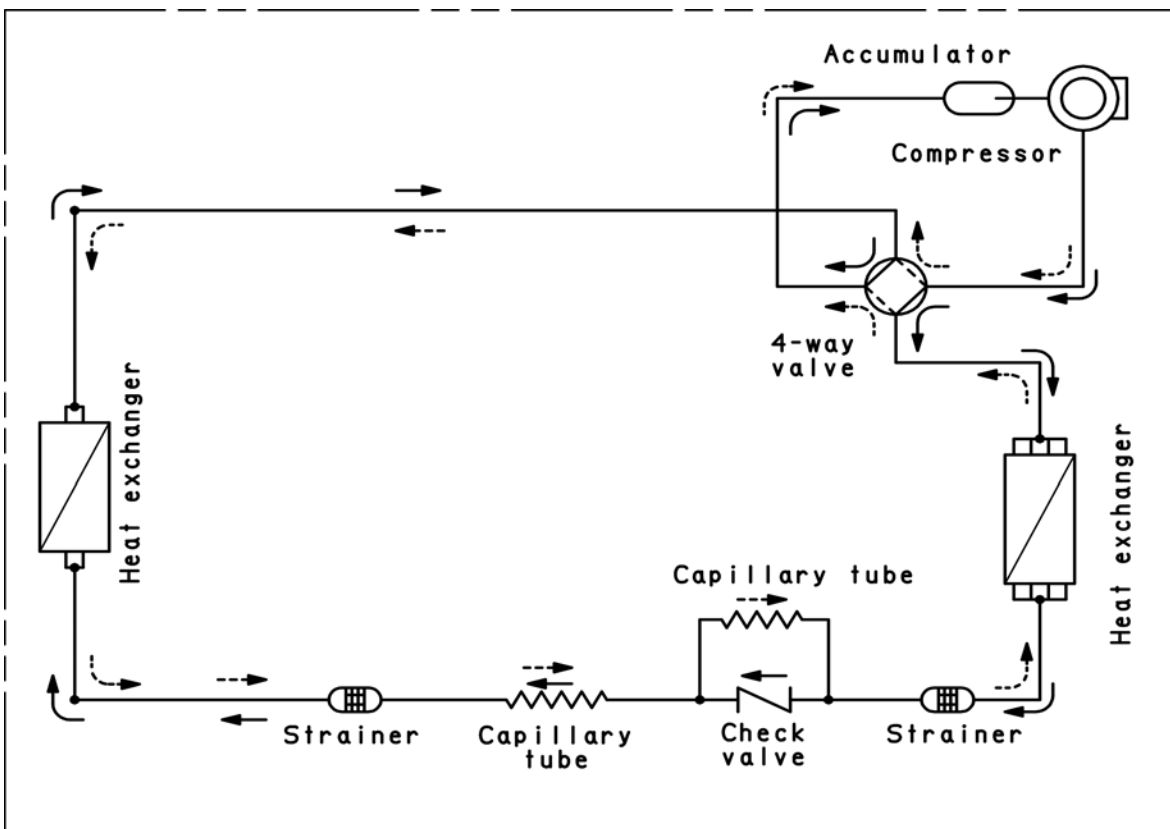

Cooling cycle ←
Heating cycle ---→

F FUNCTION

1 Cool Mode Operation

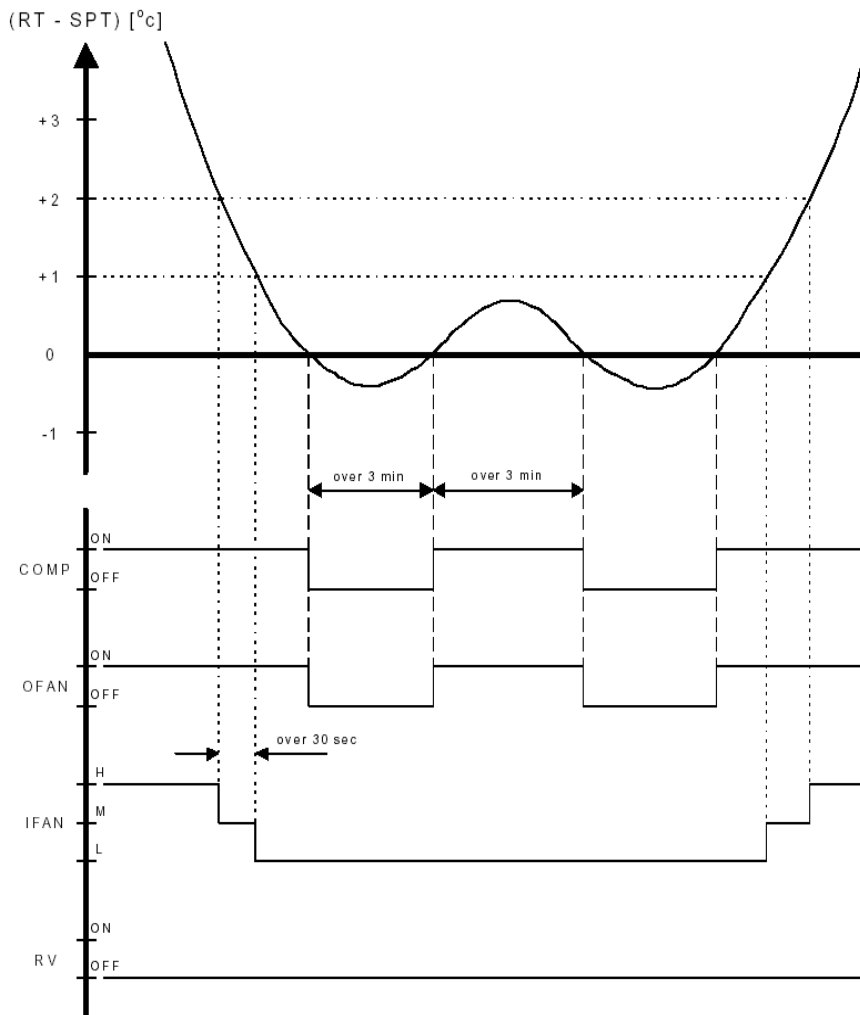

In Cool Mode, the operation of the Compressor (COMP), Outdoor Fan (OFAN) and Indoor Fan (IFAN) are determined by the difference between the Room Temperature (RT) and the Set Point Temperature (SPT) as in the graph above.

Notes:

- In this graph, the IFAN is operating in the "Auto Fan Speed" setting. If the user has selected the low, medium or high fan speed, the IFAN will run constantly at that speed only.
- In addition to the value of $(RT-SPT)$, the operations of the relays are also controlled by protection delays. For example, (a) the minimum On/Off time of the COMP is 3 min and 3 min respectively, and (b) the IFAN can change speed only after it has operated at the same speed for 30 sec in autofan setting and 1 sec for H/M/L setting.

2 Heat Mode Operation

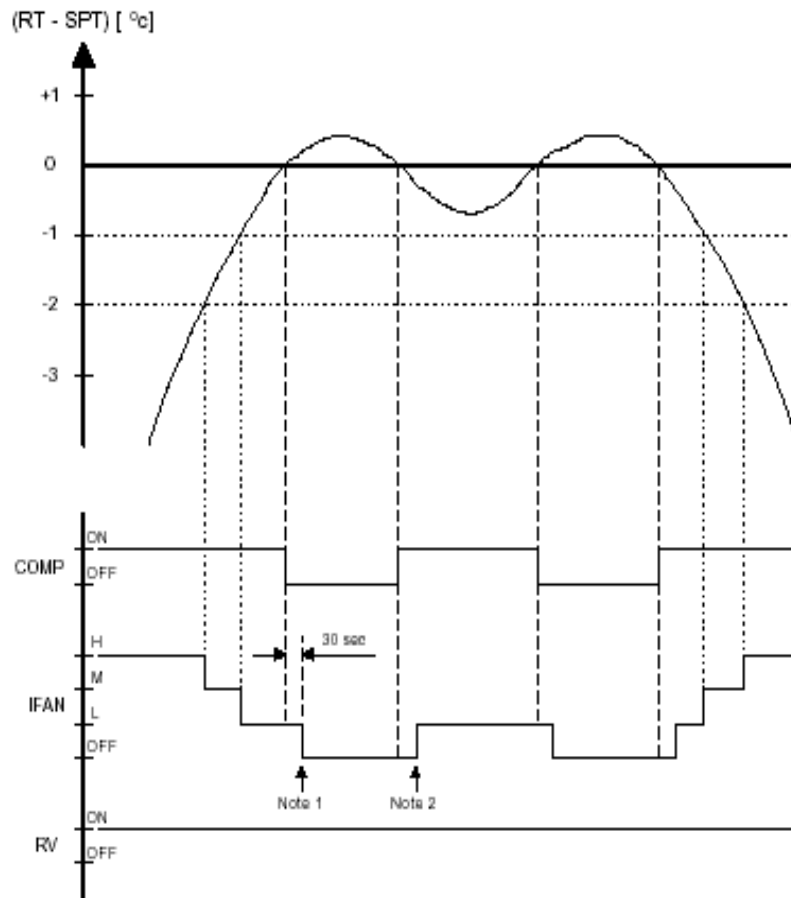

The Heat Mode operation is similar to the Cool Mode operation. The COMP, OFAN and IFAN are mainly controlled by the value of $(RT - SPT)$. In the graph above, the IFAN is operating in Auto Fan speed mode. Therefore, the IFAN speed changes automatically according to the $(RT - SPT)$.

Note 1: The 30s IFAN operation is for purging the heat from the in-coil after COMP has stopped.

Note 2: The IFAN will not be turned on until the in-coil temperature is high enough (as shown in the graph below) to prevent the unit from supplying cool air.

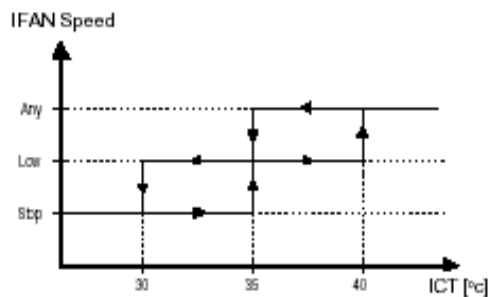

ICT = In-coil Temperature

Any = Hi, Med or Low fan speed which is selected by the user. In Auto Fan Speed Mode, the fan speed is selected by the unit automatically instead.

Low = The indoor fan is forced to operate at low speed

3 Auto (Cool/Heat) Mode Operation

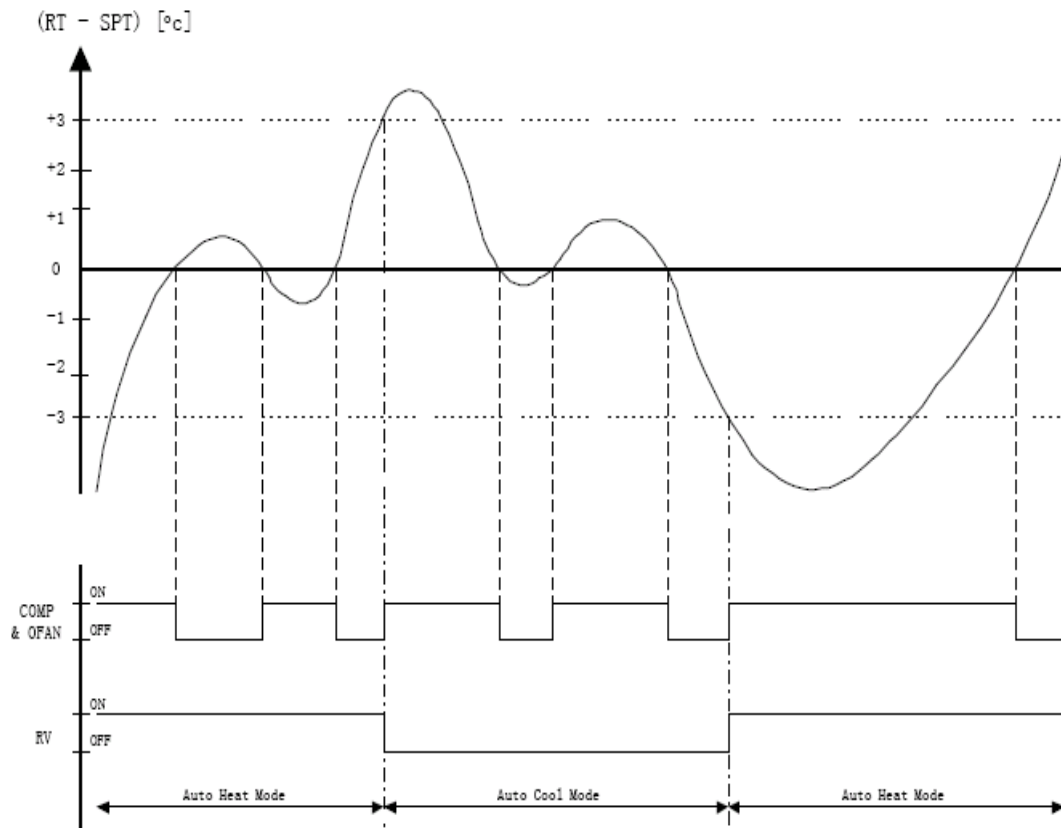

In Auto Mode, the unit switches between the Auto Cooling Mode and Auto Heating Mode automatically to maintain the room temperature (RT) at the set point temperature (SPT).

4 Dry Mode Operation

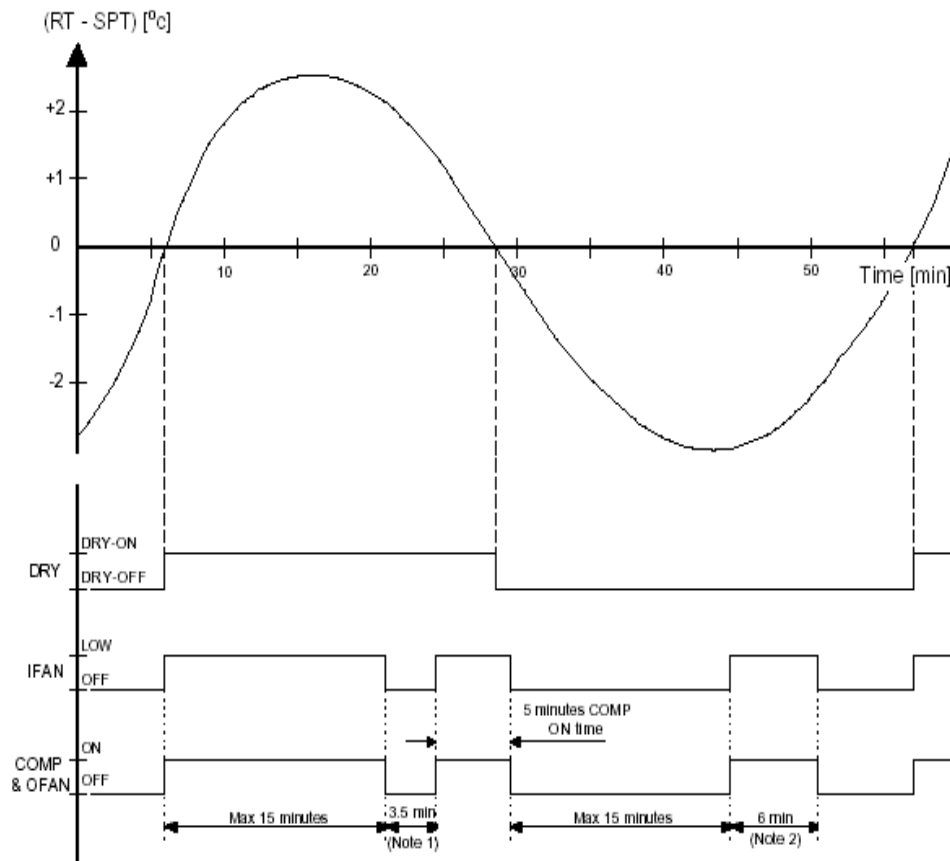

In Dry Mode, the unit operates in a mild cool mode to lower the humidity of the room. In order to maintain a high efficiency in the drying operation without over lowering the room temperature excessively, the Dry Mode is different from the Cool Mode in two ways.

- The IFAN is forced to operate at low speed only. And, the IFAN is turned off with the COMP.
- The unit operates in either the "Dry-on" state or the "Dry-off" state. If $RT < SPT$, the unit will operate in "Dry-off" state. After the COMP has stopped working for 15 min, it is forced to operate for 6 min. If $RT > SPT$, the unit will operate in "Dry-on" state. After the COMP has been working for 15 min, it is forced off for 3.5 min.

Note 1: COMP is forced off in Dry-on state.

Note 2: COMP is forced to operate in Dry-off state.

5 Fan Mode Operation

In Fan Mode, the indoor fan is turned on to improve the air circulation in the room. COMP and OFAN remain OFF all the time.

Note: If the user has selected the Auto Fan Speed setting, the IFAN speed would be selected by the unit automatically according to the difference between RT and SPT, as in Cool Mode.

6 Protection operations in Cool and Dry Mode

1. Indoor Coil Defrost Protection

The in-coil defrost protection can prevent the ice formation at the in-coil when the ambient temperature is low.

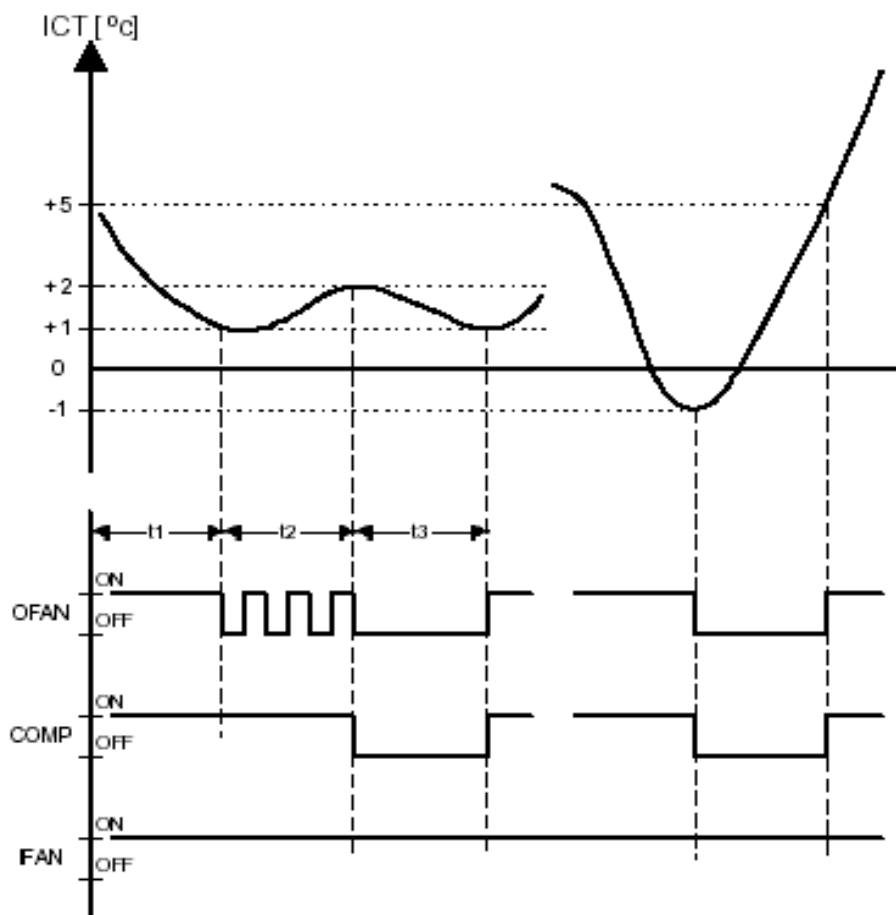

t1 = 5 min minimum for each COMP starting

t2 = OFAN cycling (alternate between ON and OFF every 30 sec) for 20 min maximum

t3 = COMP and OFAN stop for 10 min

2. Outdoor Coil High Pressure Protection

The out-coil high pressure protection prevent the build up of high pressure at the out-coil during cooling operation.

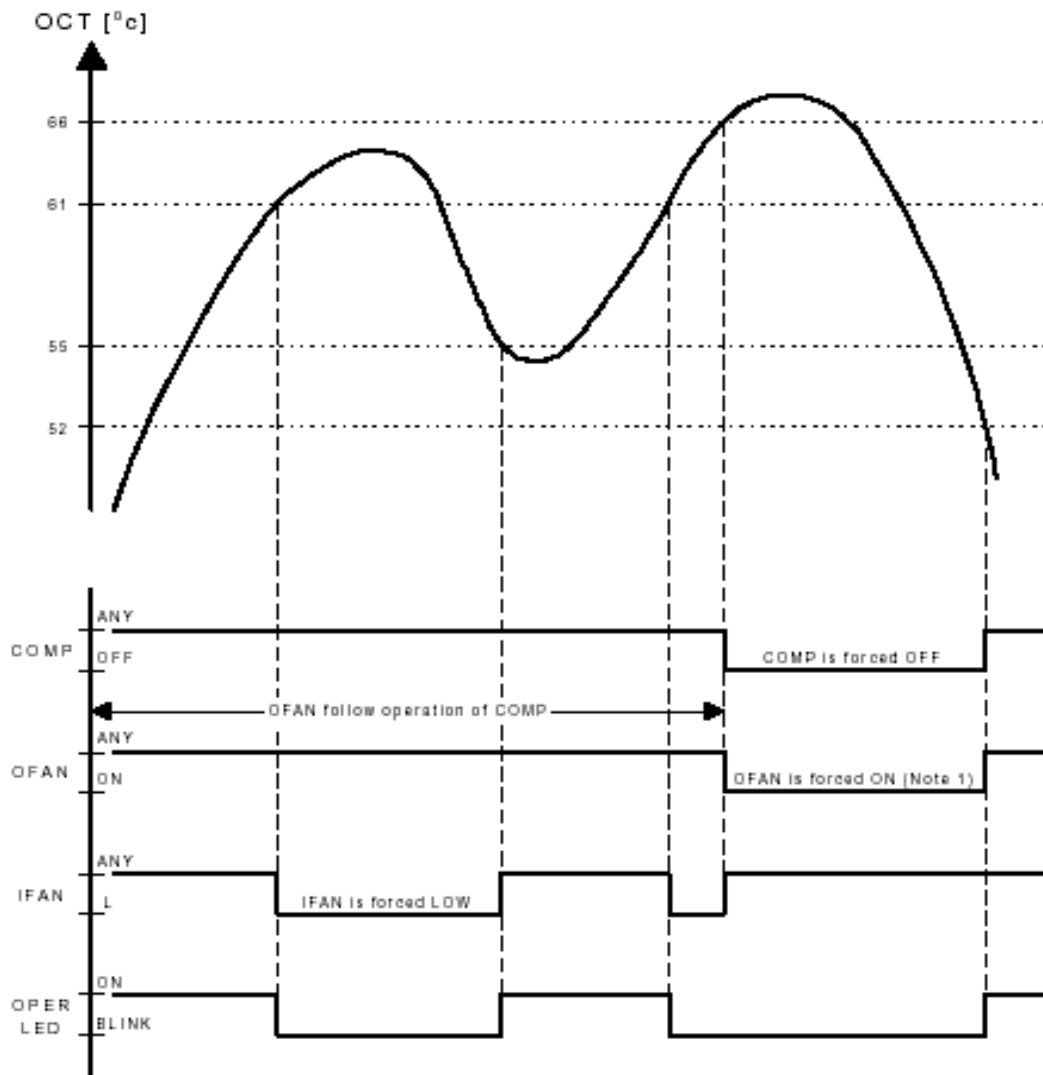

Note 1: In some applications, the outdoor fan and the compressor are controlled together by the COMP relay output from the controller. In this case, it will take more time for the out-coil to cool down during the high pressure protection, because the outdoor fan will be turned off with the compressor instead of working as in the graph above.

7 Protection Operations in Heat Mode

7-1 Outdoor Coil Deice Protection

The deice process is controlled by an Ice Detection Algorithm (IDA). The IDA is a unique control algorithm incorporated to maintain optimal utilization of the heat pump capacity, especially in below-zero outdoor temperature condition. The out-coil deicing will be activated not only by static temperature detection as normally done, but also while ice forming is detected on the out-coil.

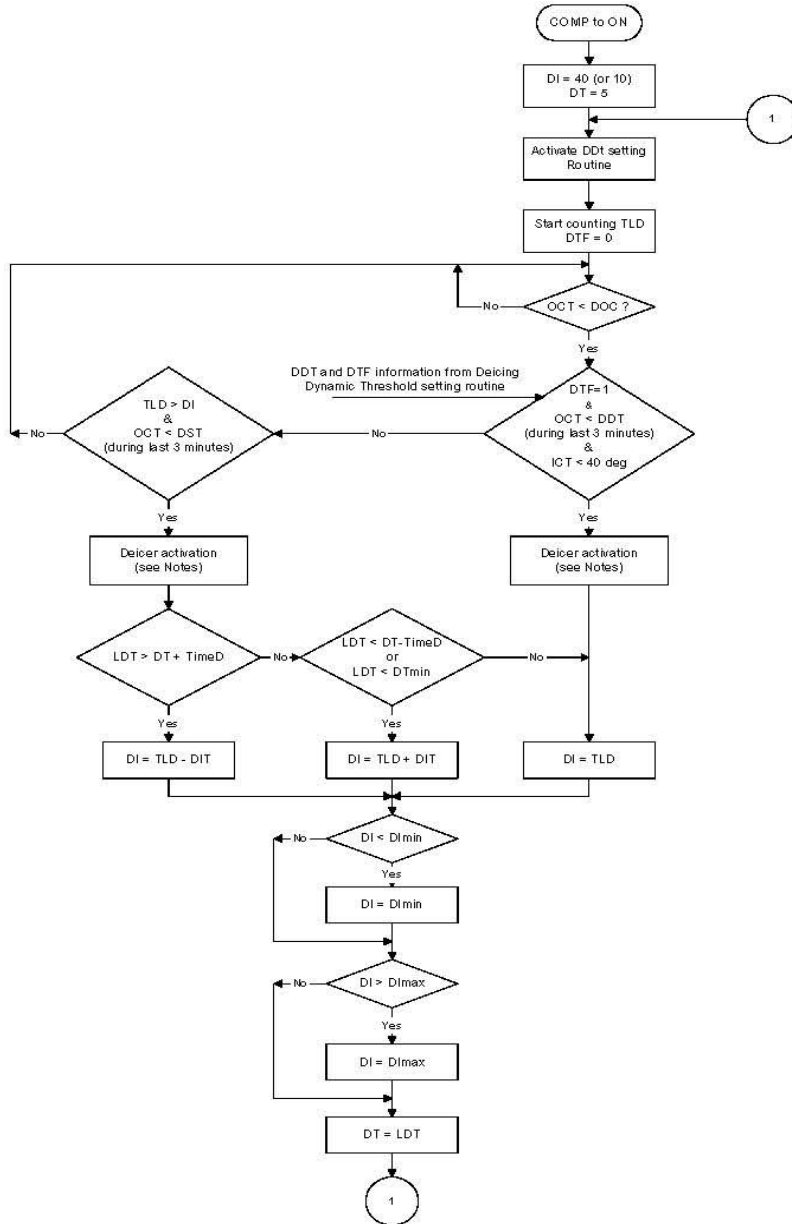

The following routine runs continuously while A/C is working in Heat Mode. The routine outputs Deicing Dynamic Threshold (DDT) and Deicer Threshold Flag (DTF) to the main Deicer routine.

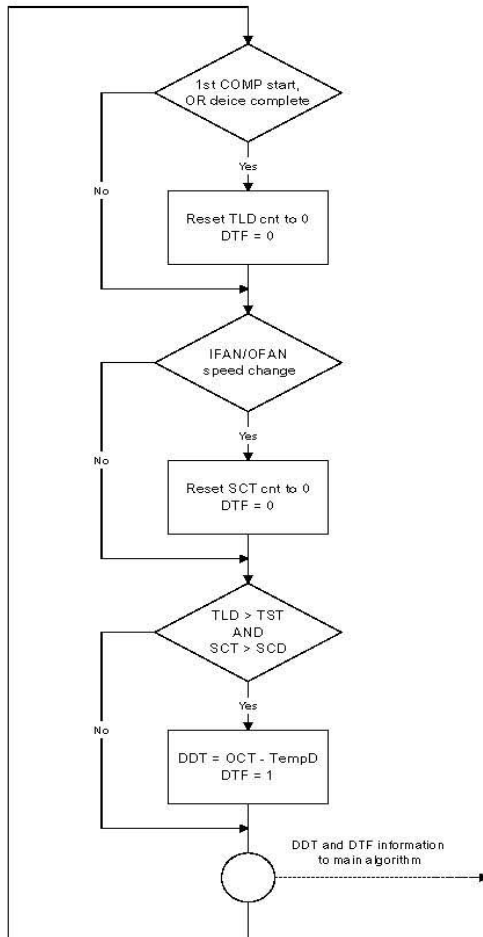

Explanation:

The “Ice Forming Detection” will be done by two algorithms –

1. In Dynamic Temp Detection, the ice formation will be detected by
 - (i) Compare the OCT with a Deicing Dynamic Temperature Threshold, and
 - (ii) Detect the drop in ICT which accompany the ice formation.
2. The Static Temp Detection will be done by comparing the OCT with a Deicing Static Temperature Threshold.

The Deicing Data Record is used to determine the time delay between two deicing cycles. In general, the time delay will be increased if the last deicing cycle can be completed quickly.

2. Indoor Coil High Pressure Protection in Heat Mode

The in-coil high pressure protection prevents the build up of high pressure at the in-coil during heating operation.

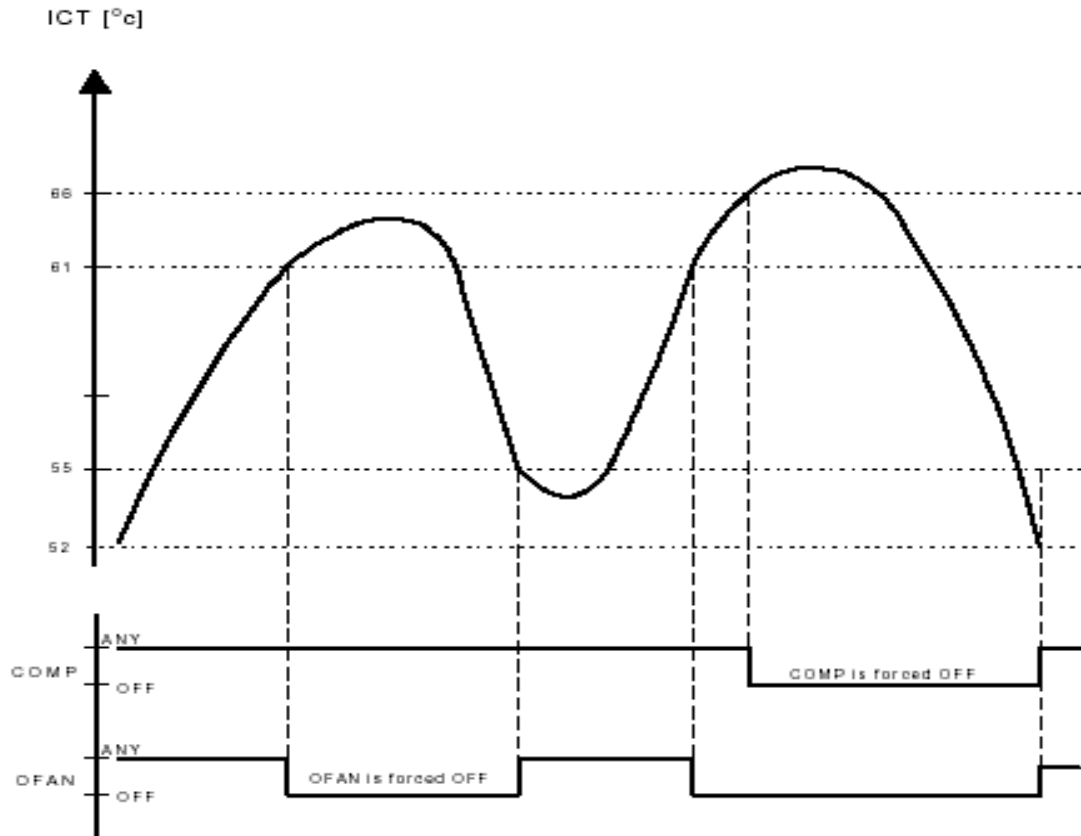

8 Sleep Function

Room temperature is automatically controlled to compensate for body temperature variations while sleeping. This mode of operation is designed for maximal comfort in both COOL and HEAT modes.

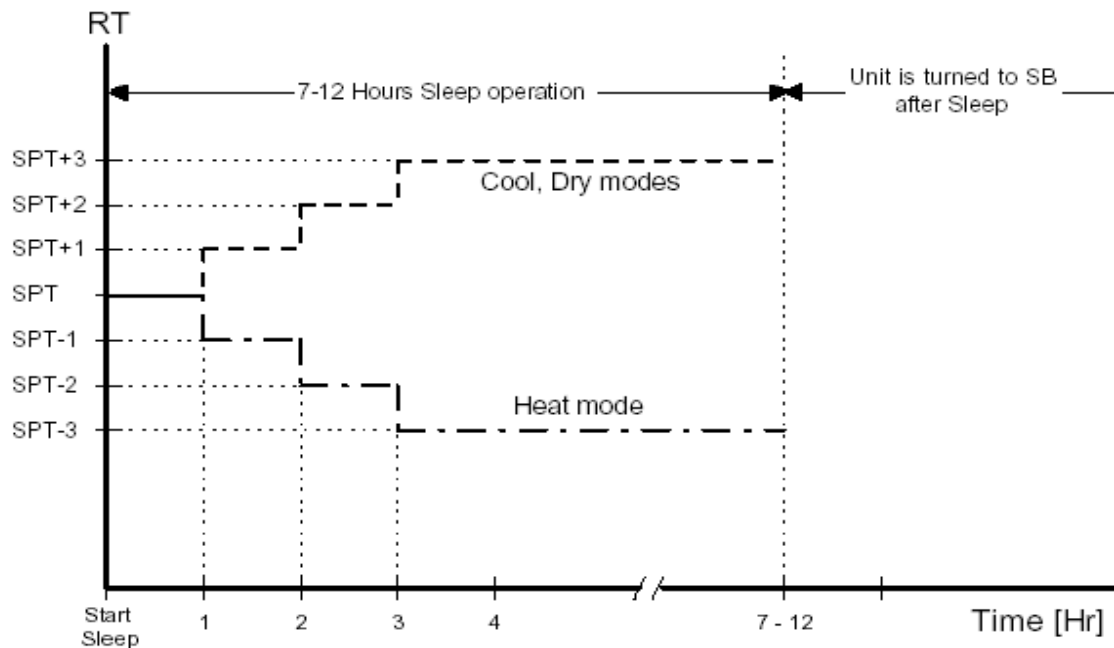

9 Daily Timer Function

There are 2 independent timers – ON Timer and OFF Timer. Unit can be programmed to be ON and OFF automatically at preset time everyday, by using a remote controller. The resolutions of the ON/OFF timers are 10 min.

10 IFEEL Function

There are 2 independent timers – ON Timer and OFF Timer. Unit can be programmed to be ON and OFF automatically at preset time everyday, by using a remote controller. The resolutions of the ON/OFF timers are 10 min.

11 Manual Unit Control and LED indicators

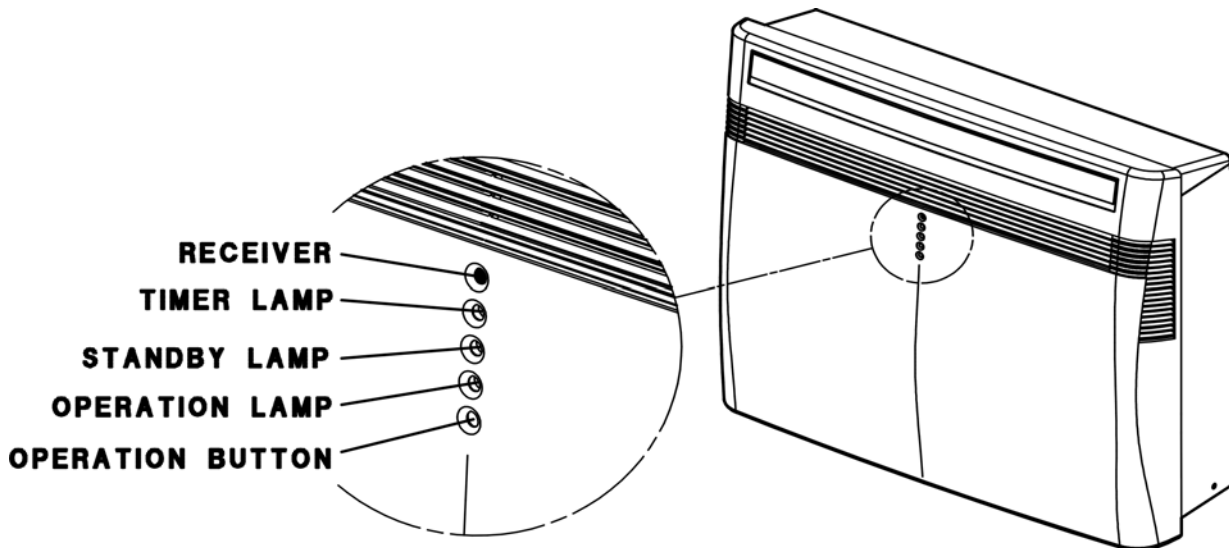

The push button switch and the LED indicators on display panel let the user to control the unit operation without a R/C (Remote Controller). Their operations are provided below.

Push Button Switch :

OPERATION BUTTON	<p>Use to cycle the operation mode of the A/C unit among COOL, HEAT and OFF modes, without using the R/C.</p> <p>Every time this switch is pressed, the next operation mode is selected, in order:</p> <ul style="list-style-type: none"> - Off => Cool mode => Heat mode => Off => ... (for heat pump model) - Off => Cool mode => Off => ... (for cooling only model) - The A/C will start in Auto IFAN speed and Flap mode as the last setting. The temperature setting is 22°C for cooling and 28°C for heating mode.
---------------------	---

WARNING:

the OFF position does not disconnect the power. Use the main power switch to turn off power completely.

Led indicators :

TIMER LAMP	<ol style="list-style-type: none"> 1. Lights up during Timer and sleep operation. 2. Blinks continuously in case of any wiring trouble.
STANDBY LAMP	<ol style="list-style-type: none"> 1. Lights up when the Air conditioner is connected to power and ready to receive the Remote Control command. 2. Blinks continuously in case of any thermistor failure.
OPERATION LAMP	<ol style="list-style-type: none"> 1. Lights up in Operation mode (Note: OFF in standby mode). 2. Blinks for 0,5 sec., to announce that a R/C infrared signal has been received and stored. 3. Blinks continuously during: <ul style="list-style-type: none"> - OCT (outdoor coil temp.) High pressure protection Mode - Deicing in Heating Mode 4. Blinks continuously in case of FS (Float Switch) trips for high water level.

12 Recovery from Power Failure

Last unit settings (SPT, operation mode, louver settings, etc) are saved in the EEPROM in the unit. In case of power failure, these settings are restored automatically.

12 Outdoor fan operation

Outdoor fan speed change from HI to Low according to outdoor air temperature as indicated on the chart below.

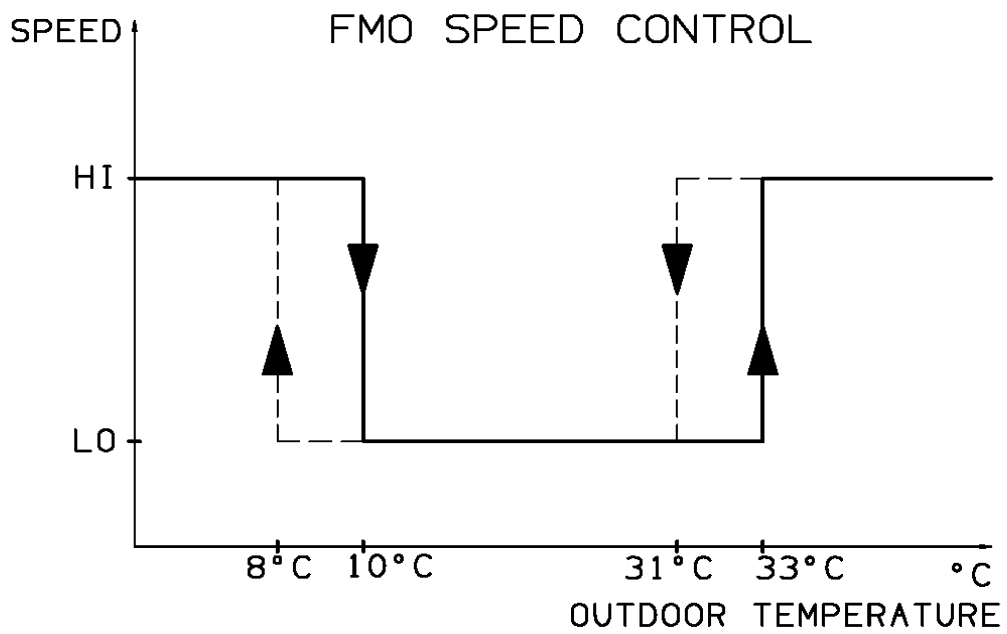

1- Cooling only model

ARGO 245C

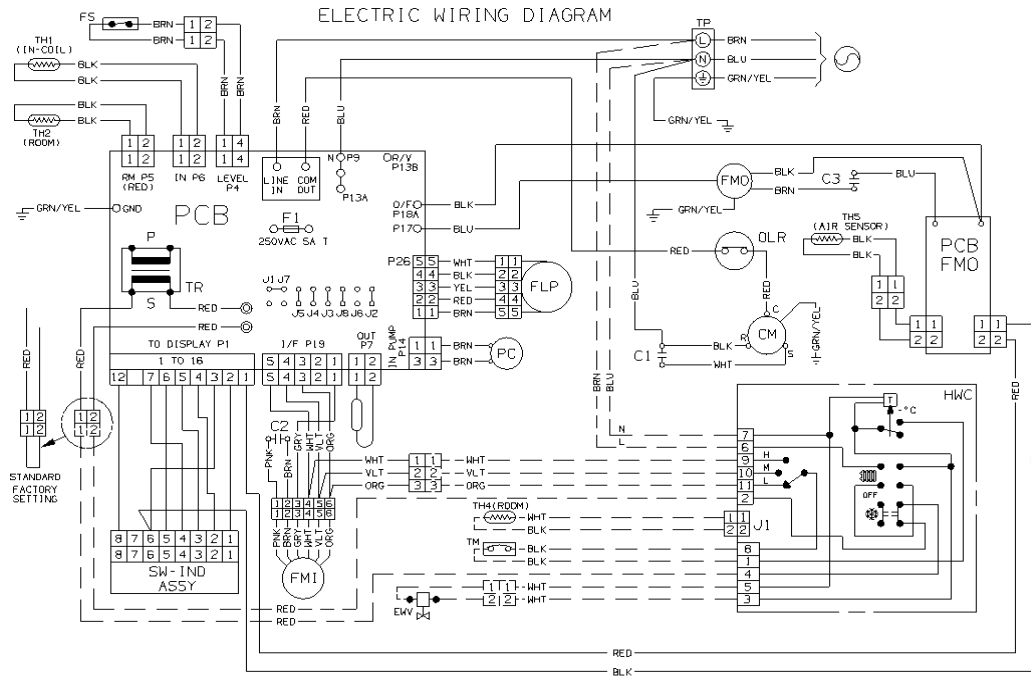

--- = COLLEGAMENTI CONTROLLO HWC, RISCALDAMENTO ACQUA CALDA (ACCESSORIO)
 ELECTRIC WIRING FOR HWC, HOT WATER CONTROL (ACCESSORY)

ARGO 35C

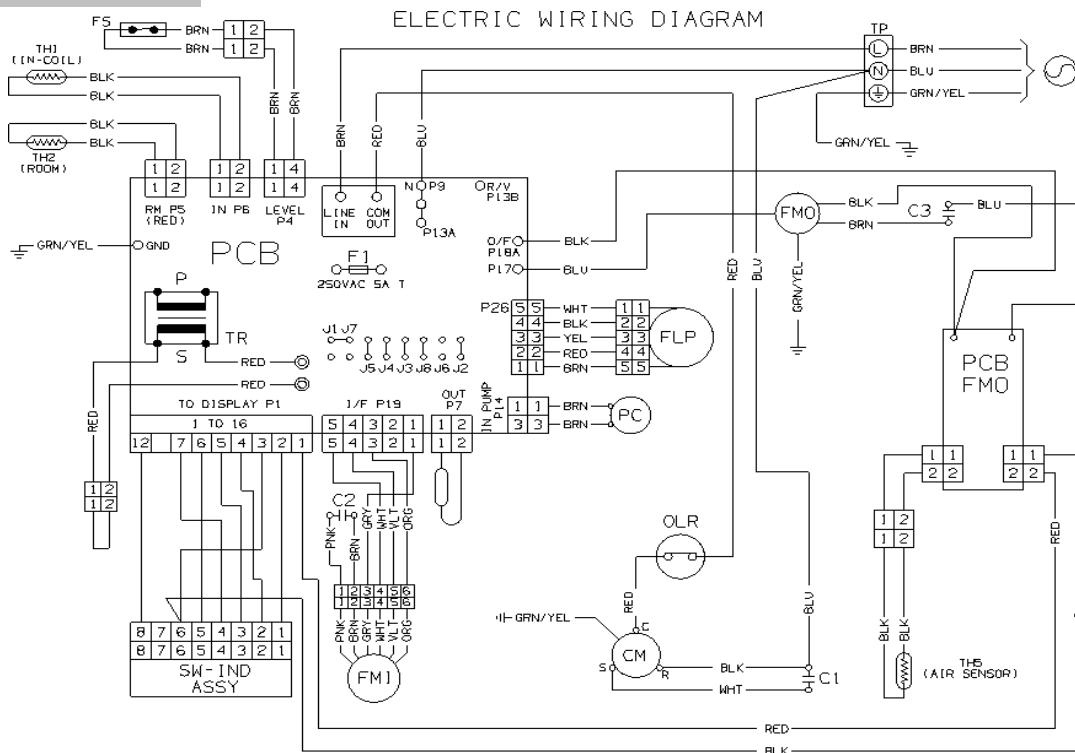

LEGENDA

PCB	Controller	SW-IND-ASSY	Indicator assy
FMI	Indoor fan motor	TH1-2-3-4-5	Thermistor
TR	Power transformer	TP	Terminal plate
CM	Compressor motor	HWC	Hot water control
OLR	Overload relay	TM	Limit water thermostat
FMO	Outdoor fan motor	EWV	Water electric valve
C1-2-3	Capacitor	FS	Float switch
PC	Condensate pump motor	FLP	Flap motor
20S	4-way valve	F1	Fuse
PCB/FMO	Controller Outdoor fan motor		

2- Heat pump model

ARGO 235H

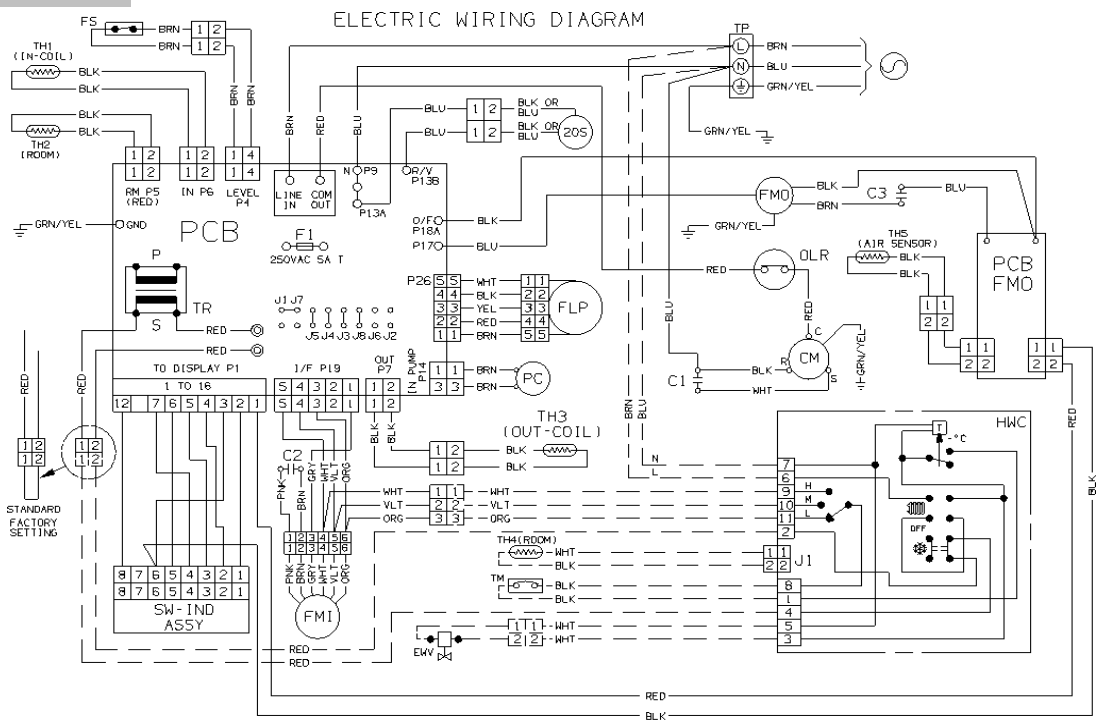

--- = COLLEGAMENTO CONTROLLO HWC, RISCALDAMENTO ACQUA CALDA (ACCESSORIO)
ELECTRIC WIRING FOR HWC, HOT WATER CONTROL (ACCESSORY)

ARGO 3HP

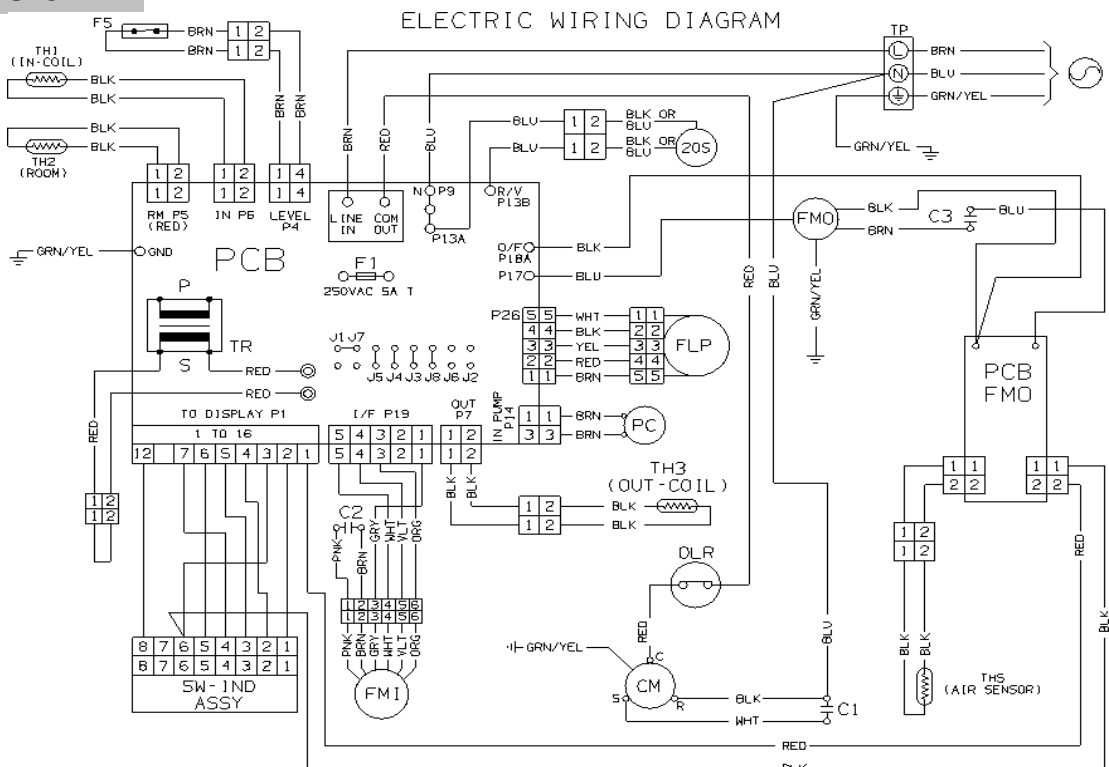

LEGENDA

PCB	Controller	SW-IND-ASSY	Indicator assy
FMI	Indoor fan motor	TH1-2-3-4-5	Thermistor
TR	Power transformer	TP	Terminal plate
CM	Compressor motor	HWC	Hot water control
OLR	Overload relay	TM	Limit water thermostat
FMO	Outdoor fan motor	EWW	Water electric valve
C1-2-3	Capacitor	FS	Float switch
PC	Condensate pump motor	FLP	Flap motor
20S	4-way valve	F1	Fuse
PCB/FMO	Controller Outdoor fan motor		

H TROUBLESHOOTING

CHECK BEFORE AND AFTER «TROUBLESHOOTING»

(A) Check power supply wiring.

- WARNING: If the following troubleshooting must be done with power being supplied, be careful about any uninsulated live part that can cause ELECTRIC SHOCK.

(B) Check power supply.

- Check that voltage is in specified range ($\pm 10\%$ of the rating).
- Check that power is being supplied

SYSTEMATIC CHART OF «TROUBLESHOOTING»

AIR CONDITIONER DOES NOT OPERATE

A Circuit breaker trips (or fuse blows)

- When circuit breaker is set to ON, it trips in a few moments. (Resetting is not possible).
- Measure insulation resistance there is a possibility of ground fault. If resistance value is 1 M Ω or less, insulation is defective.

B Circuit breaker trips in several minutes after turning air conditioner ON.

① • There is a possibility of short circuit.

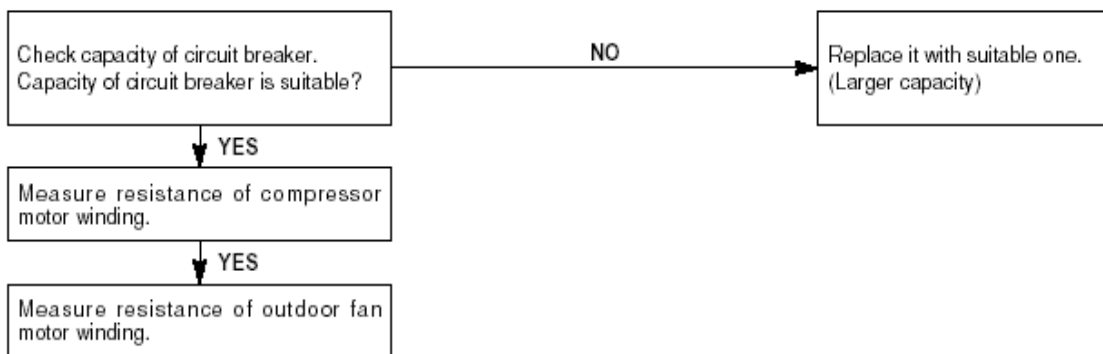

② • The unit does not run.

Power is not supplied.

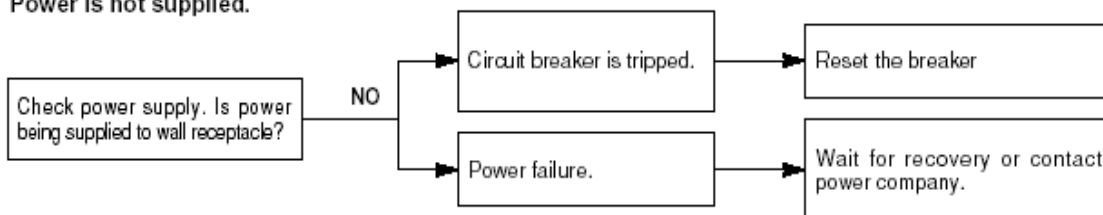

Check fuse on PCB Ass'y.

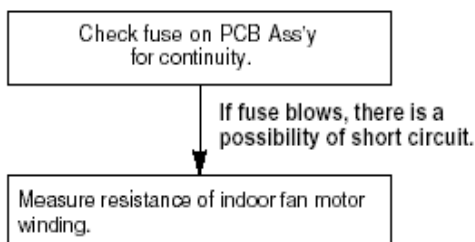

C Water - level alarm (Operation lamp is blinking)

Malfunctioning of the condensate drainage system

NOTE - In case of emergency the air conditioner can work by draining the condensate from the little pipe into a rather short container, extract the little pipe and remove the cap.

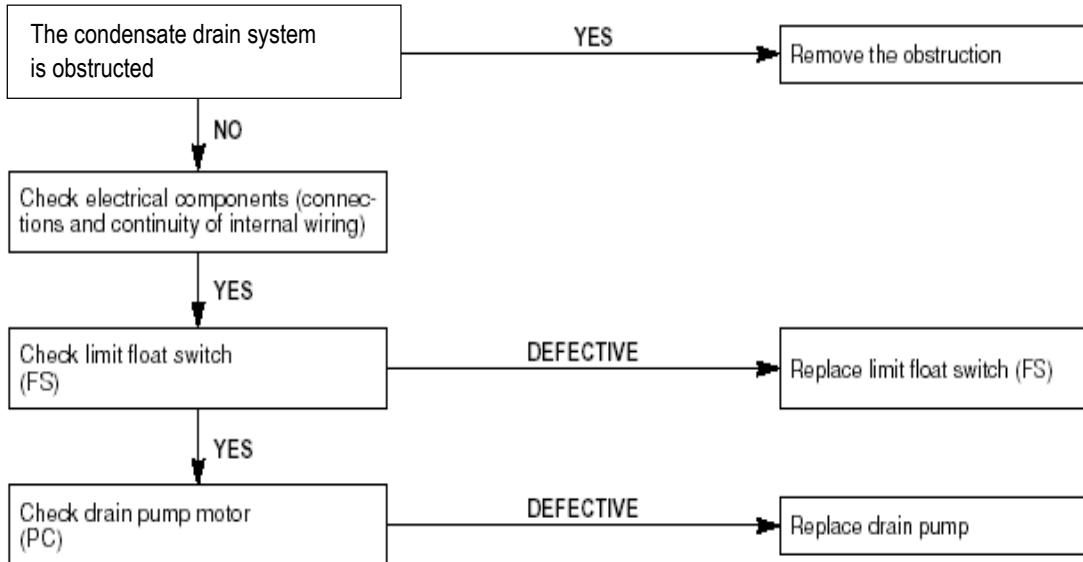

D Unit and compressor do not run

The unit does not run when air conditioner is in following conditions.

- When the room temperature is below the setting temperature.
- During freeze prevention.

Check setting temperature

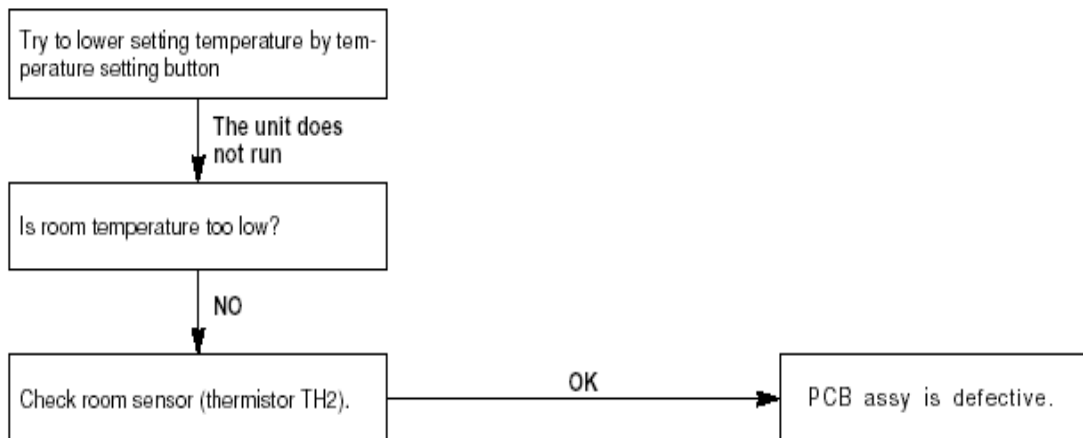

E SOME PART OF AIR CONDITIONER DOES NOT OPERATE

1) ONLY INDOOR FAN DOES NOT RUN

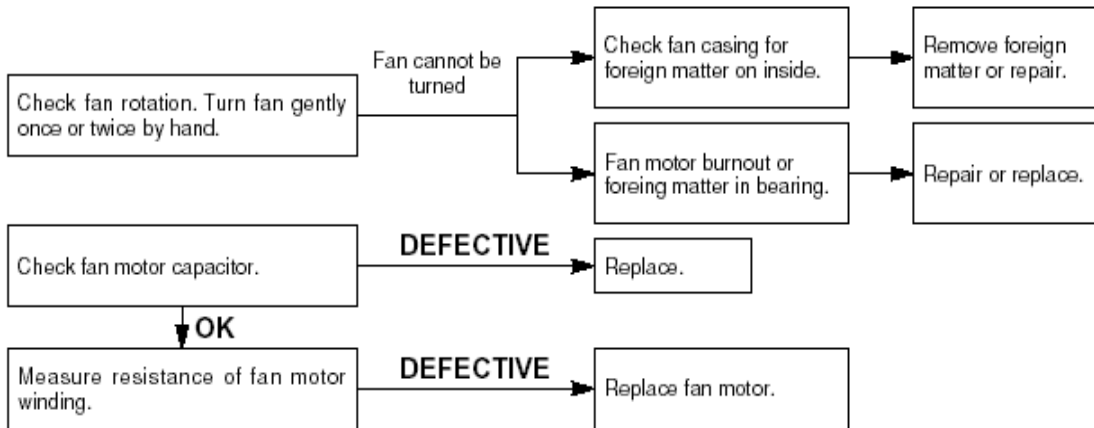

2) ONLY OUTDOOR FAN DOES NOT RUN

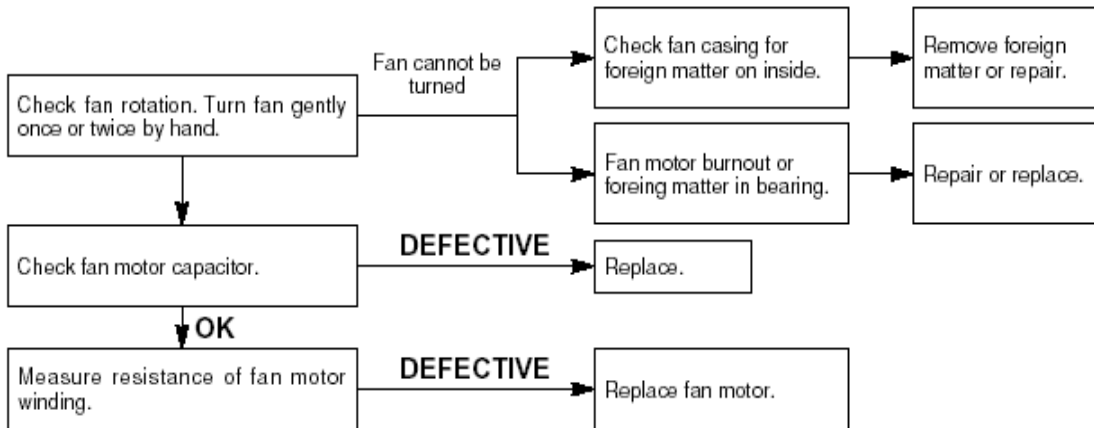

3) ONLY COMPRESSOR MOTOR DOES NOT RUN

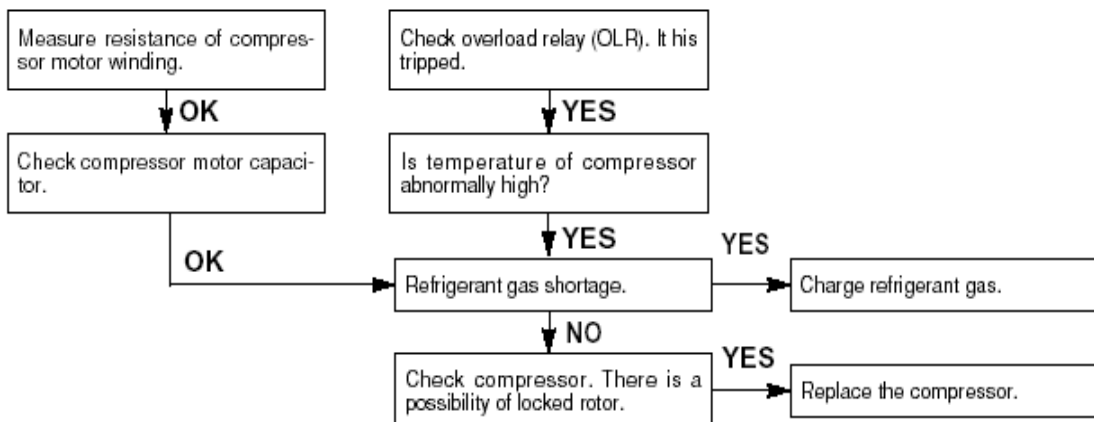

F AIR CONDITIONER OPERATES, BUT ABNORMALITIES ARE OBSERVED (HEAT PUMP MODEL)

1) Operation does not switch from heat to cool (or cool to heat)

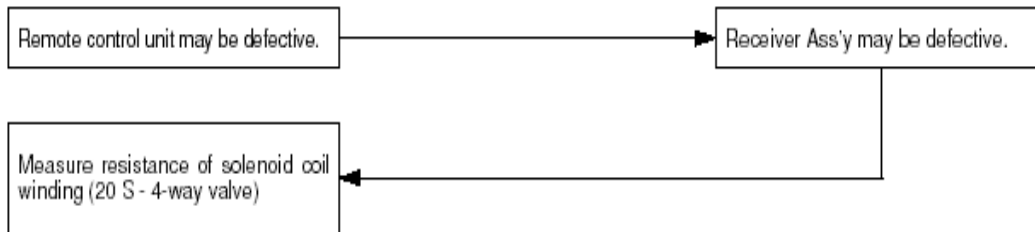

(2) Check "OPERATION BUTTON" on the unit

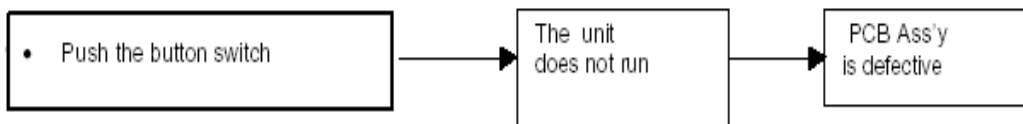

(3) Check remote control unit.

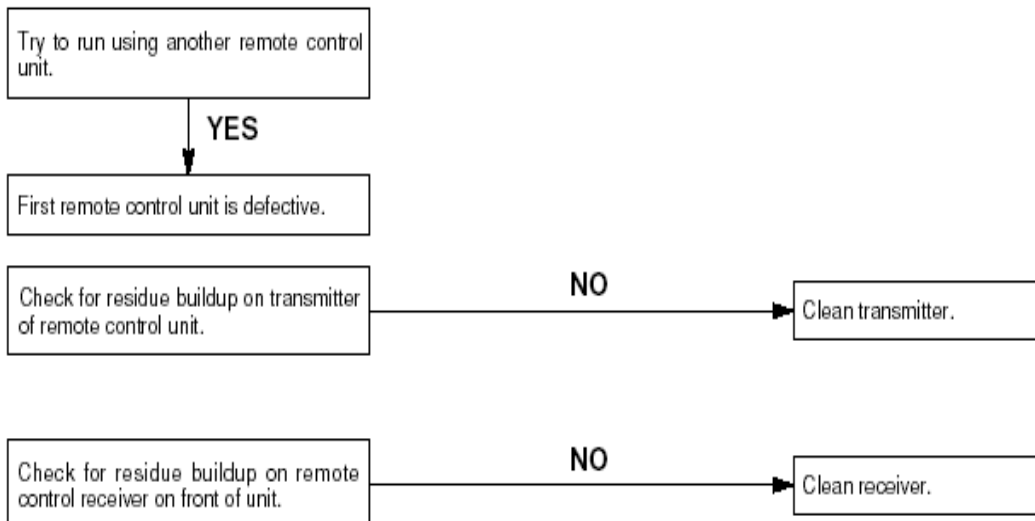

(4) Check fuse on PCB Ass'y in the unit.

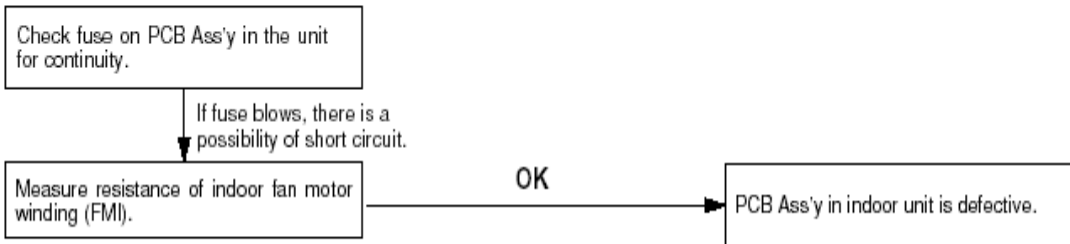

(5) Check setting temperature.

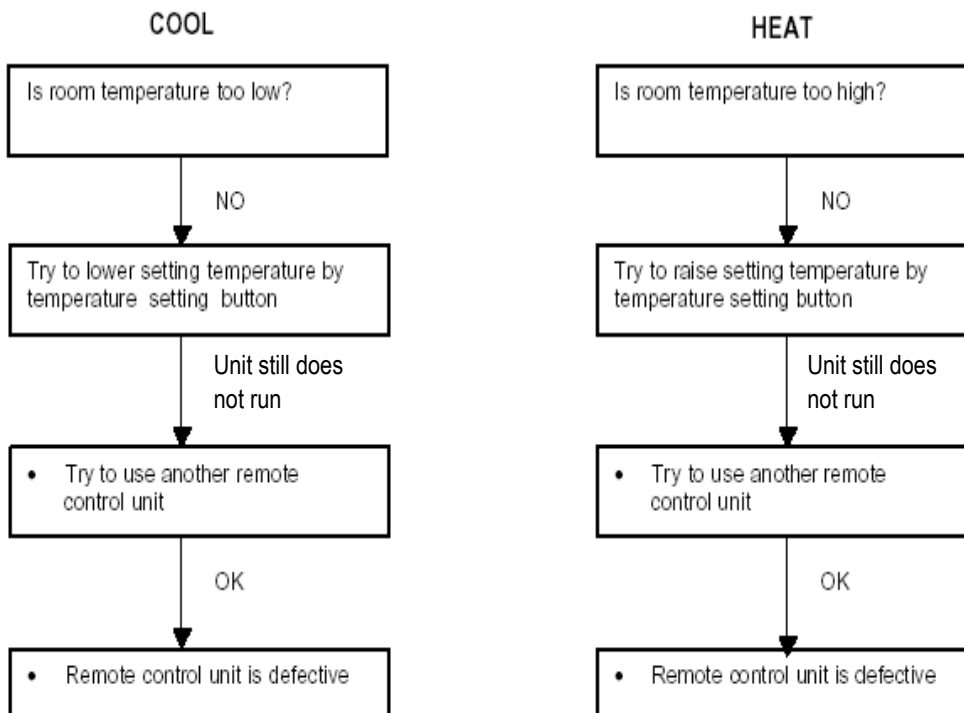

G POOR COOLING OR POOR HEATING

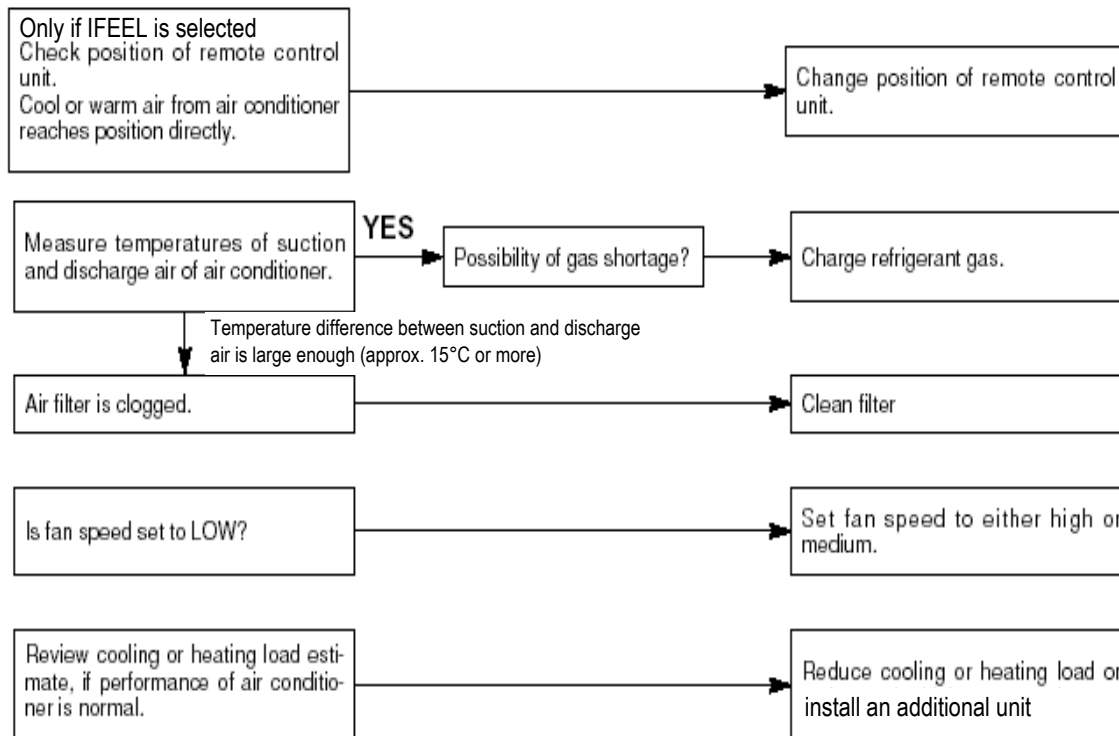

H EXCESSIVE COOLING OR HEATING



I IF A SENSOR IS DEFECTIVE

ICT (indoor coil sensor) OCT (outdoor coil sensor) RT (room ambient temperature) are defective.

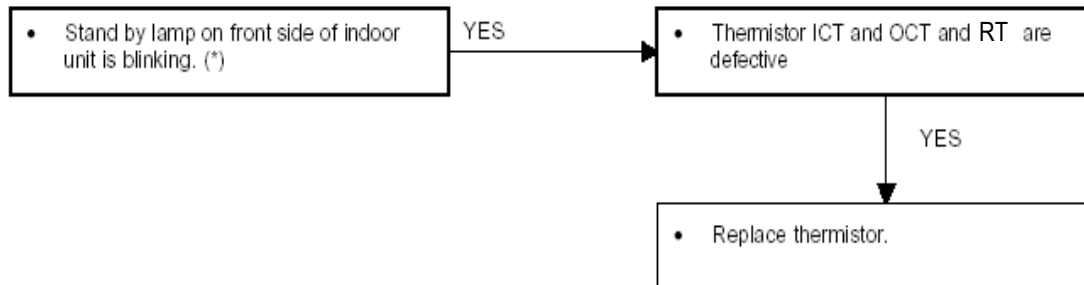

NOTE Alarm signal (*)

Standby lamp on the front side of the indoor unit will blink when the thermistor is defective. At the same time the outdoor unit will stop. Indoor operate only for ventilation.

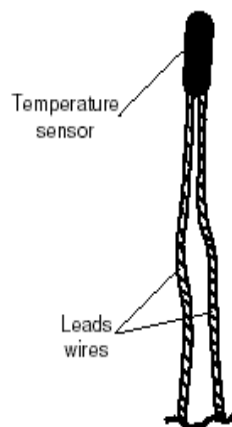

I**REFRIGERANT CHARGE**

	ARGO 245C / 3SC	ARGO 235H /3HP
REFRIGERANT CHARGE R410A	600 g	520 g

IMPORTANT

In order to recharge the unit use the high-pressure side gate.

Preliminary operation after refrigerant charge



CHECKING ELECTRICAL COMPONENTS

1) Measurement of Insulation Resistance

- The insulation is in good condition if the resistance exceeds 1M Ω m.

a) Power Supply Wires

Clamp the earthed wire of the power supply wires with the lead clip of the insulation resistance tester and measure the resistance by placing a probe on either of the power wires (Fig. 1). Then measure the resistance between the earthed wire and the other power wires (Fig. 1).

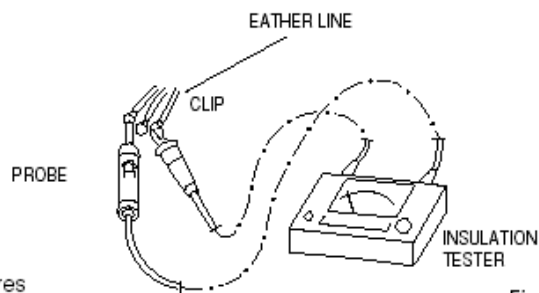

Fig. 1

b) Unit

Clamp an aluminium plate fin or copper tube with the lead clip of the insulation resistance tester and measure the resistance by placing a probe on N terminal, and then on L terminal the terminal plate (Fig. 2).

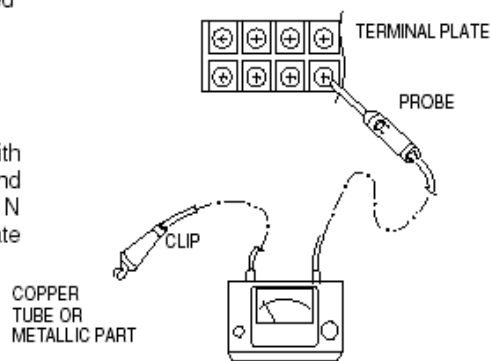

Fig. 2

c) Measurement of Insulation Resistance for Electrical Parts

Disconnect the lead wires of the disired electric part from terminal plate, PCB Ass'y, capacitor, etc. Similarly disconnect the connector. Then measure the insuration resistance. (Fig. 1 to 4). Refer to Electric Wiring Diagram

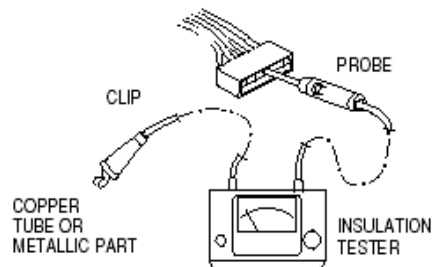

Fig. 3

NOTE

- If the probe cannot enter the poles because the hole is too narrow then use a probe with a thinner pin.

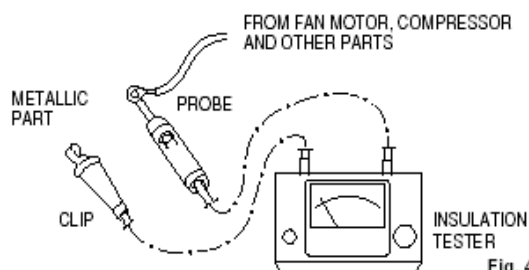

Fig. 4

2) Checking Continuity of Fuse on PCB Ass'y

- Remove PCB Ass'y from electrical component box. (Fig. 5).
- Then pull out the fuse from PCB Ass'y.

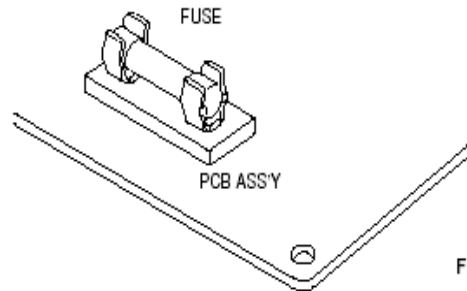

Fig. 5

- Check continuity of fuse by the multimeter (Fig. 6).

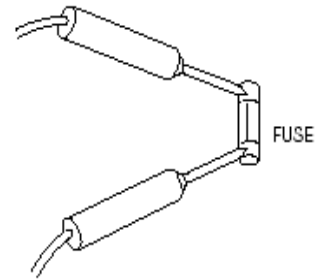

Fig. 6

3) Checking Motor Capacitor

- Remove the lead wires from the capacitor terminals, and then place a probe on the capacitor terminals as shown in Fig. 7. Observe the deflection of the pointer, setting the resistance measuring range of the multimeter to the maximum value. The capacitor is "good" if the pointer bounces to a great extent and the gradually returns to its original position. The range of deflection and deflection time differ according to capacity of the capacitor.

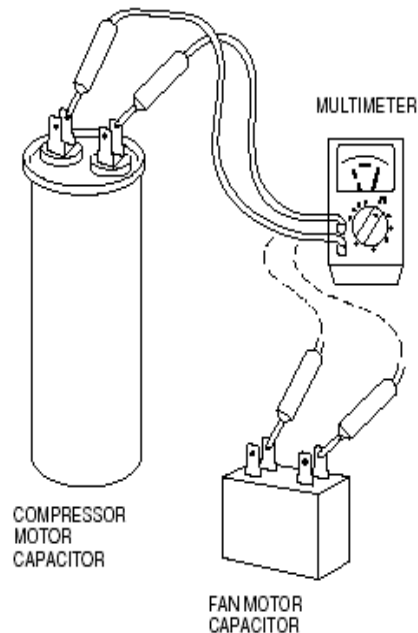
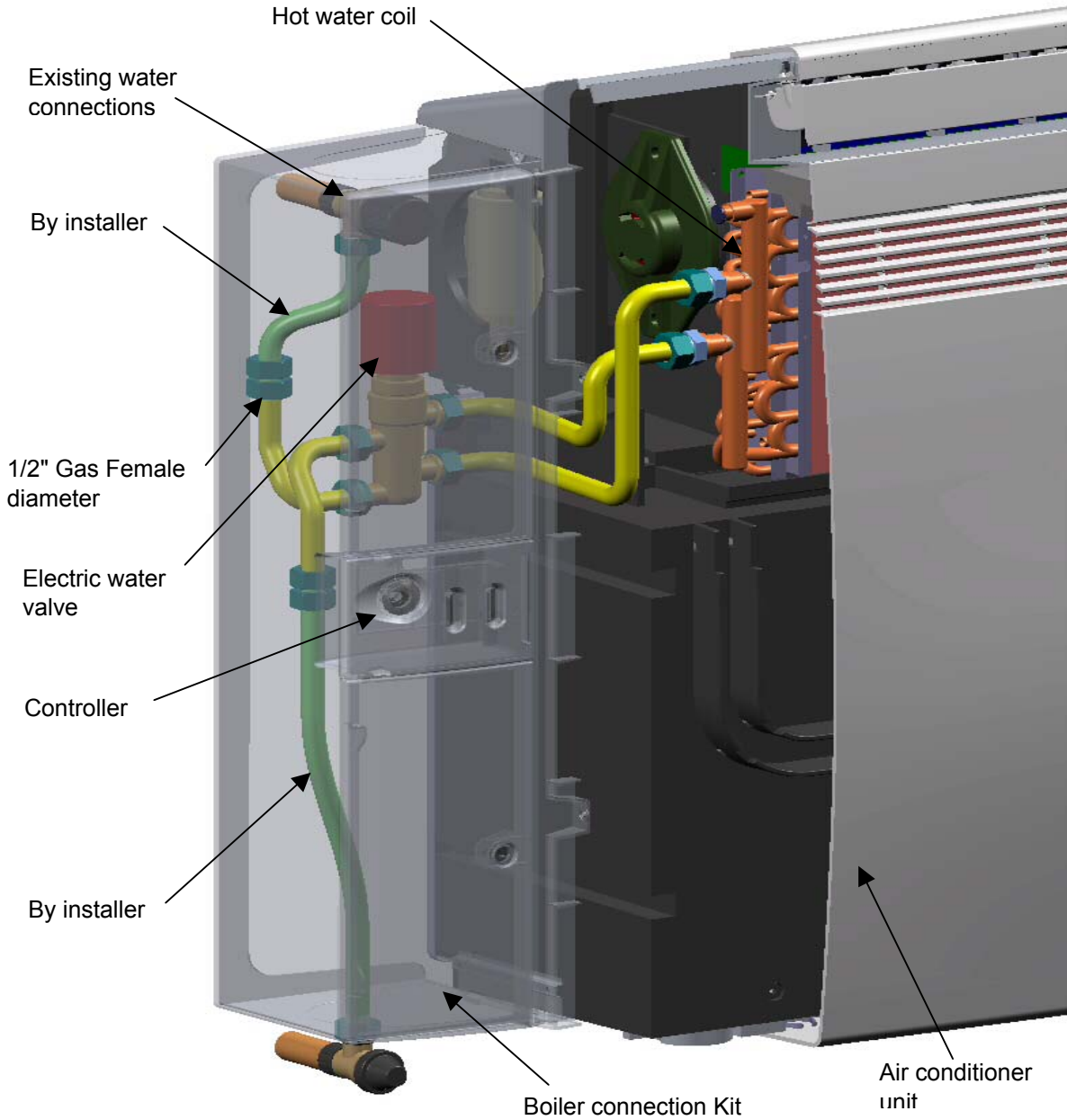

Fig. 7

Typical installation



1) SPECIFICATIONS

Power source		230 V ~ 50 Hz
Capacity at standard conditions	W	2100
Power input	W	27
Fan speed		3 (Hi - Me - Lo)
Standard conditions:	Ambient temp. °C	20
	Fan speed	High
	Inlet water temp. °C	70
	ΔT water K	10
Water coil only	ΔP water kPa	0,7 (70 mmH2O)
	water flow l/h	155 (2,6 l/min.)
Valve and tubes including	ΔP water kPa	2,9 (290 mmH2O)
	water flow l/h	190 (3,1 l/min.)

OPERATING LIMITS

Max temperature inlet hot water	°C	70°C
Max pressure	bar	10

2) PERFORMANCE CHARTS

Performance on different conditions

Capacity reduction factor : High speed = 1 ; Med. speed = 0,96 ; Low speed = 0,93

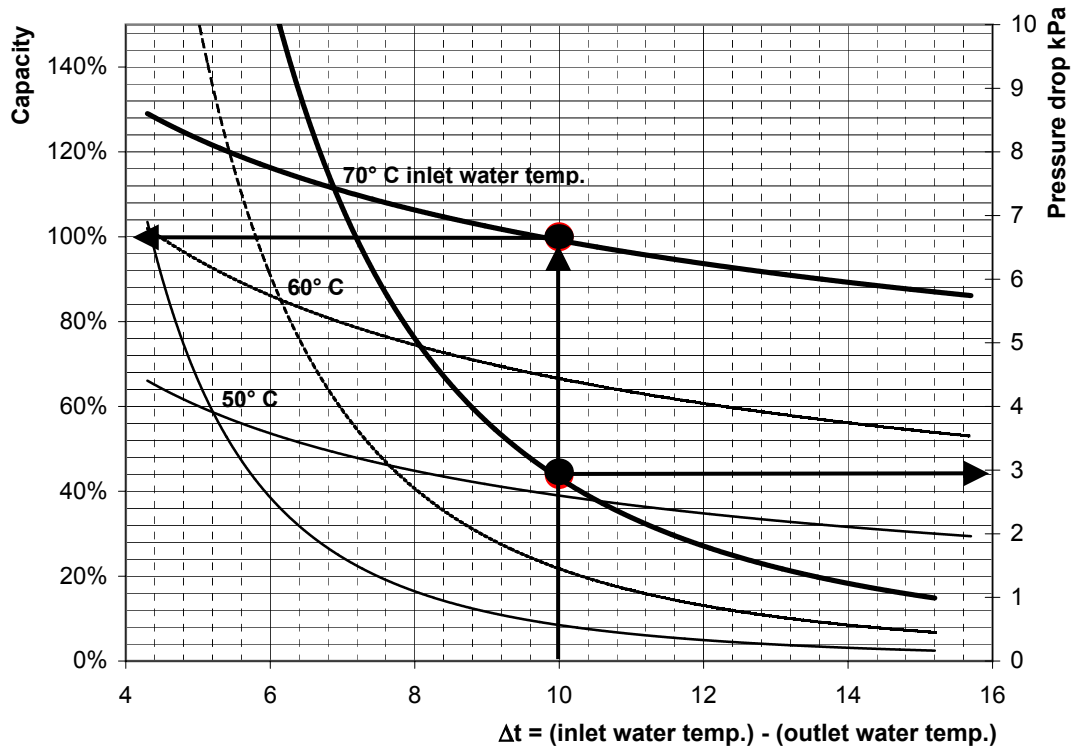

WATER FLOW AND PRESSURE DROP – (3 WAY VALVE AND PIPE INCLUDING)

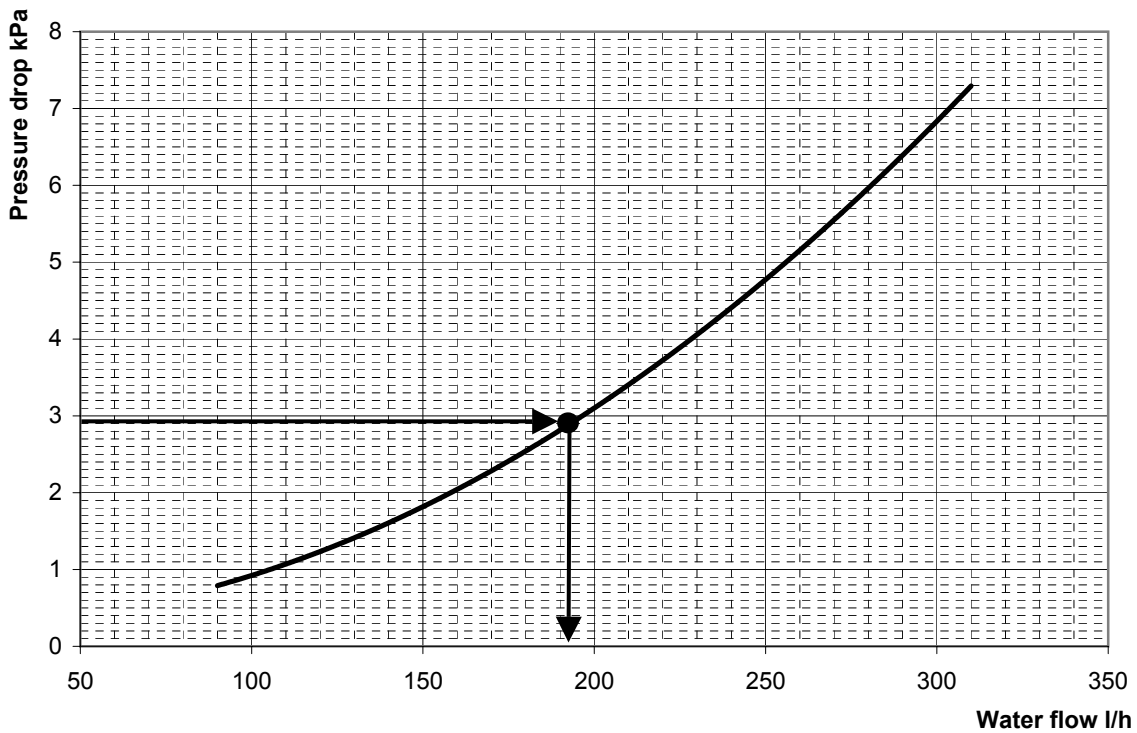

3) COMPONENT SPECIFICATIONS (Boiler connection kit)

CONTROLLER (HWC)		
Type		000TSA
Controls		Manual
Thermostat	Setting	6°C ±1°C ÷ 30°C ±1°C
	Differential	1K
THERMISTOR (ROOM SENSOR) TH4		
Type		STLNGY050
Resistance (at 25° C)	kΩ	4,7 ±2%
as alternative CONTROLLER (HWC)		
Type		078564-00
Controls		Manual
Thermostat	Setting	6°C ±1°C ÷ 30°C ±1°C
	Differential	1K
THERMISTOR (ROOM SENSOR) TH4		
Type		77798
Resistance (at 25° C)	kΩ	6,8 ±2%
LIMIT WATER THERMOSTAT (TM)		
Electrical rating		10(1,6) A - 250Vac
Control		Autoreset
setting		Open : 31°C ±3°C - Close: 42°C±4°C
Differential		11K
WATER ELECTRIC VALVE (EWV)		
Electric Thermal Actuator	Type	VA-7040-23
Supply voltage		230VAC ± 15%
Power consumption:	Continuous	2,5 W
	Start-up	36 W (150 mA) max
Nominal force		125 N
Nominal stroke		4,5 mm
Full stroke time at 50°C	Actuator stem	extends : 60 sec
	Actuator stem	retract : 10 min
3-way Forged brass valve	Type	VG-5510EC
Body Type		3-way NO bypass
Threaded Male Connection		1/2" Gas
Close-Off Pressure	kPa	100
Water HEAT EXCHANGER COIL		
Coil	Type	Aluminium plate fin / Copper tube
Rows		1
Fin pitch	mm	2,0
Face area	m ²	0,102
Threaded Male Connection		1/2" Gas

3) HYDRAULIC CONNECTIONS AND VALVES

- ① HOT WATER COIL
- ② 1/2" GAS CONTROL VALVE
- ③ 1/2" GAS HOLDER
- ④ 1/2" GAS WATER ELECTRIC VALVE

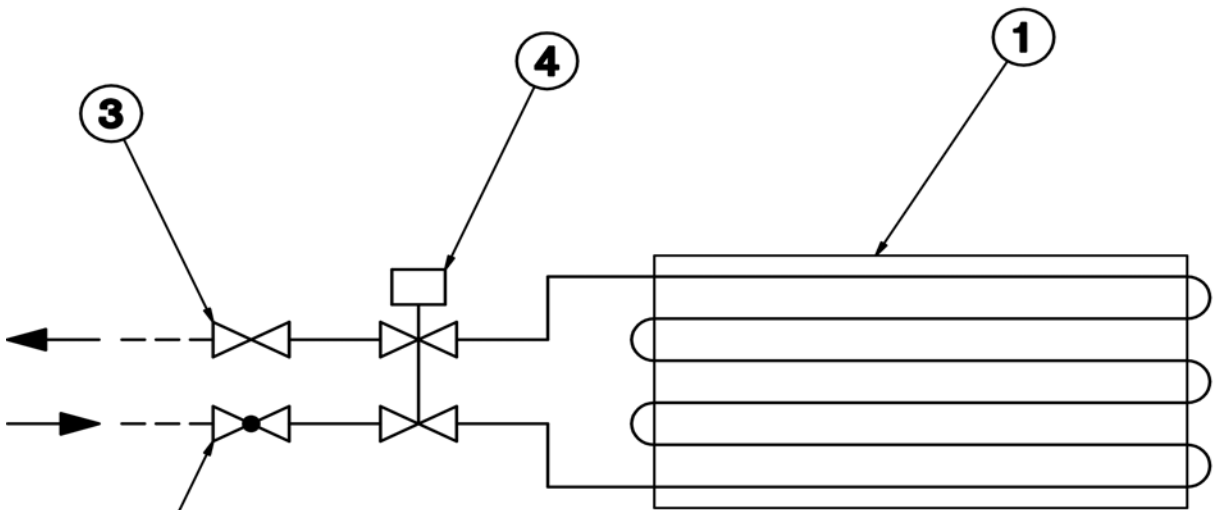

④ Actuator stem down

④ Actuator stem up

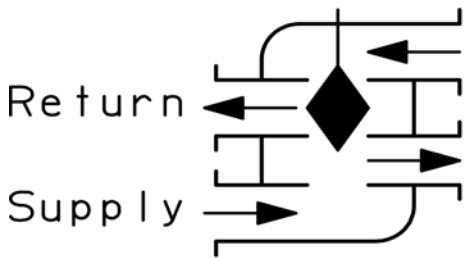

3-way NO ByPass

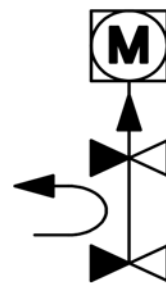

argoclima s.p.a.

Via Varese, 90 - 21013 Gallarate - Va - Italy
Tel. +39 0331 755111 - Fax +39 0331 776240
www.argoclima.it