

# Service Manual

Air Conditioner

CS-F18DTE5 CU-J18DBE5



## ⚠ WARNING

This service information is designed for experienced repair technicians only and is not designed for use by the general public. It does not contain warnings or cautions to advise non-technical individuals of potential dangers in attempting to service a product. Products powered by electricity should be serviced or repaired only by experienced professional technicians. Any attempt to service or repair the product or products dealt with in this service information by anyone else could result in serious injury or death.

## ⚠ PRECAUTION OF LOW TEMPERATURE

In order to avoid frostbite, be assured of no refrigerant leakage during the installation or repairing of refrigeration circuit.

## TABLE OF CONTENTS

	PAGE		PAGE
<b>1 Service Information</b> -----	<b>3</b>	2.3. Wired Remote Control -----	7
1.1. Example of trouble at test operation -----	3	2.4. Wireless Remote Control -----	7
1.2. Caution of test operation-----	3	2.5. Group Control Equipment-----	8
1.3. Caution during automatic address setting-----	3	<b>3 Product Specification</b> -----	<b>9</b>
1.4. Operation range-----	4	3.1. CS-F18DTE5 CU-J18DBE5-----	9
<b>2 Features</b> -----	<b>5</b>	3.2. Safety Devices-----	10
2.1. Ceiling Type-----	5	<b>4 Dimensions</b> -----	<b>11</b>
2.2. Outdoor Unit -----	5	4.1. CS-F18DTE5-----	11

# Panasonic®

© 2006 Panasonic HA Air-Conditioning (M) Sdn Bhd (11969-T). All rights reserved. Unauthorized copying and distribution is a violation of law.

4.2. CU-J18DBE5-----	12	15.1. CS-F18DTE5 -----	103
<b>5 Refrigeration Cycle-----</b>	<b>13</b>	<b>16 Exploded View (Outdoor Unit) -----</b>	<b>105</b>
5.1. CS-F18DTE5 CU-J18DBE5-----	13	16.1. CU-J18DBE5 -----	105
<b>6 Block Diagram -----</b>	<b>14</b>	16.2. CU-J18DBE5 -----	106
6.1. CS-F18DTE5-----	14	<b>17 Replacement Part List (Outdoor Unit)-----</b>	<b>107</b>
6.2. CU-J18DBE5 -----	14	17.1. CU-J18DBE5 -----	107
<b>7 Wiring Diagram -----</b>	<b>15</b>	<b>18 Print Pattern -----</b>	<b>108</b>
7.1. CS-F18DTE5 -----	15	18.1. Indoor Unit Printed (Main)-----	108
7.2. CU-J18DBE5-----	16	18.2. Indoor Unit Printed (Indicator)-----	109
<b>8 Operation Instructions -----</b>	<b>17</b>	18.3. Outdoor Unit (Main)-----	109
8.1. Wired Remote Control-----	17		
8.2. Remote Control - Display -----	18		
8.3. Remote Control - Panel -----	19		
8.4. How to set remote control day and time-----	20		
8.5. How To Select The Timer -----	20		
8.6. Daily Timer Setting-----	21		
8.7. Weekly Timer Setting-----	22		
8.8. Wireless Remote Control-----	24		
<b>9 Operation Details-----</b>	<b>25</b>		
9.1. Cooling Operation-----	25		
9.2. Soft Dry Operation -----	25		
9.3. Auto Operation-----	25		
9.4. Fan Operation-----	25		
9.5. Normal Control-----	26		
9.6. Operation Control -----	27		
9.7. Protection Control-----	28		
9.8. Test Run -----	29		
<b>10 Installation Instruction -----</b>	<b>30</b>		
10.1. Pipe length-----	30		
10.2. Refrigerant additional charge -----	30		
10.3. Position of the centre gravity -----	31		
10.4. Indoor unit installation-----	32		
10.5. Outdoor unit installation -----	42		
10.6. Wired remote control installation -----	54		
10.7. Wireless remote control installation manual-----	62		
<b>11 Installation and Servicing Air Conditioner Using</b>			
<b>R410A -----</b>	<b>69</b>		
11.1. Outline -----	69		
11.2. Tools for installing/servicing refrigerant piping ----	70		
11.3. Refrigerant piping work-----	74		
11.4. Installation, transferring, servicing -----	76		
<b>12 Troubleshooting Guide-----</b>	<b>80</b>		
12.1. For standard installation-----	80		
12.2. During group control operation -----	82		
12.3. Test operation and self-diagnosis -----	83		
12.4. Emergency operation -----	87		
12.5. Self-diagnosis error code table -----	89		
<b>13 Technical Data-----</b>	<b>91</b>		
13.1. Cooling capacity performance data-----	91		
13.2. Capacity and power consumption-----	92		
13.3. Reaching distance -----	95		
13.4. Sound data-----	96		
13.5. Sound measuring point-----	97		
13.6. Fan performance -----	98		
13.7. Discharge and suction pressure-----	99		
13.8. Operating characteristics-----	99		
<b>14 Exploded View (Indoor Unit) -----</b>	<b>100</b>		
14.1. CS-F18DTE5-----	100		
14.2. CS-F18DTE5-----	101		
14.3. CS-F18DTE5-----	102		
<b>15 Replacement Part List (Indoor Unit)-----</b>	<b>103</b>		

# 1 Service Information

<b>Notice of Address setting for NEW Cassette / NEW Outdoor Unit.</b>
---

**The new Cassette / New Outdoor models are possible to have address setting for twin control by automatic when main power supply is switched on.**

(Manual address setting is also possible by using Dip switch on Indoor unit P.C. board.) However, **this address setting is only possible when made proper wiring connection and also Indoor unit should be original virgin unit.**

## 1.1. Example of trouble at test operation

If found out as following phenomenon at test operation on site, it may have possibility of wrong address setting. Therefore, please ensure of the address setting.

1. LCD display of wired remote control had not illuminate although the main power supply switch is 'on'.
2. LCD display had indicated as normal illumination when power supply switch is 'on', however outdoor unit cannot be operated. (But, it is necessary to take 3 to 5 minutes for outdoor unit to start from the timing of remote control ON/OFF switch is 'on'.)
3. P.C. board had memorized wrong setting information.
  - a. If main power supply is switched 'on' with the wrong connection.
  - b. When changing the connection or combination of units due to re-installation etc.
    - When changing the system from group control to normal one to one system.
    - When making the replacement of units as master and slave etc.

## 1.2. Caution of test operation

Do not touch the remote control switch and do not change any wirings for one minute when the main power supply switch is 'on'. (Because the unit is having automatic address setting during the first one minute.)

## 1.3. Caution during automatic address setting

When main power supply switch is 'on', the P.C. board will automatically memorize the connecting system. Consequently, when initial power supply is 'on', there will not be interchangeability of units even of the same type and same capacity unit. Therefore unable to connect the unit to another system.

## 1.4. Operation range

### 1.4.1. Power Supply

The applicable voltage range for each unit is given in the following table. The working voltage among the three phases must be balanced within a 3% deviation from each voltage at the compressor terminals. The starting voltage must be higher than 85% of the rated voltage.

MODEL	Unit Main Power		Applicable Voltage	
	Phase, Volts	Hz	Max.	Min.
CU- J18DBE5	1 ~ 220	50	242	198
	1 ~ 230	50	253	207
	1 ~ 240	50	264	216

### 1.4.2. Indoor and Outdoor Temperature

- Model 50Hz CU-J18DBE5

Operating	Hz	Indoor Temp. (D.B./W.B.) (°C)		Outdoor Temp. (D.B./W.B.) (°C)	
		Max.	Min.	Max.	Min.
Cooling	50	32/23	21/15	43/-	-5/-

## 2 Features

### 2.1. Ceiling Type

#### 2.1.1. Easier Maintenance and Cleaning

- Anti-Mould Long Life Air Filter.
- 3-Direction Pipe Lead-Out.

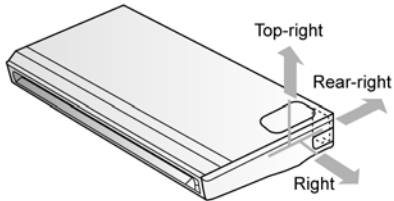

#### 2.1.2. Wide Air Discharge, Comfortable Control

- Wide-Angle Airflow — 100 Degrees Horizontal.
- Auto Swing Louver.

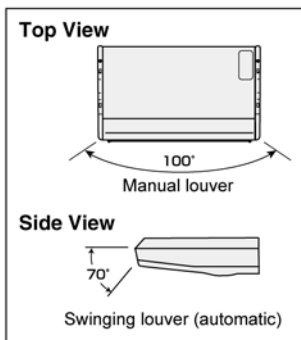

### 2.2. Outdoor Unit

#### 2.2.1. Flexible Installation in Smaller Spaces

- Long Pipe design with maximum piping length of 30m.
- Flexible 4-way piping.

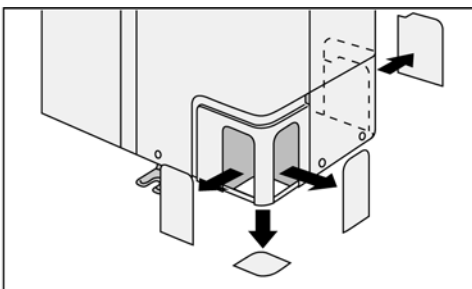

- Centralized Drain Method gathered multiple outdoor unit's drain pipes into a single drain pipe to makes installation easier and also improve appearance.

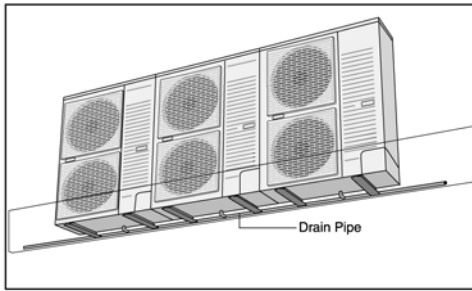

- Side-by-Side Continuous Installation is possible even outdoor units with different capacities.

### 2.2.2. Quiet, Efficient Design

- A host of silencing technologies achieves super-quiet operation.
- The Noise-Suppressing Winglet Fan is a result of new research into vane design theory. The unique curved shaped suppressed the generation of vortices, thus reduces air flows noise.



- Operating efficiency is improved and energy consumption reduced.

### 2.2.3. Low Ambient Cooling Operation

- The unit can set for cooling even when the outdoor temperature drops to  $-10^{\circ}\text{C}$ . This is ideal for location such as non-residential computer room (where the temperature is not less than  $21^{\circ}\text{C}$  and humidity is not more than 45%) that require cooling even in winter.

## 2.3. Wired Remote Control

1. The new design includes an easily-visible red pilot lamp. The power can be turned on and off at a single touch, without opening the cover.
2. Has a built-in thermistor, allowing indoor temperature detection in accordance with indoor conditions by switching with main unit thermistor.
3. Twin non-polar wires make installation work easy. (10 m cable supplied as accessory.)

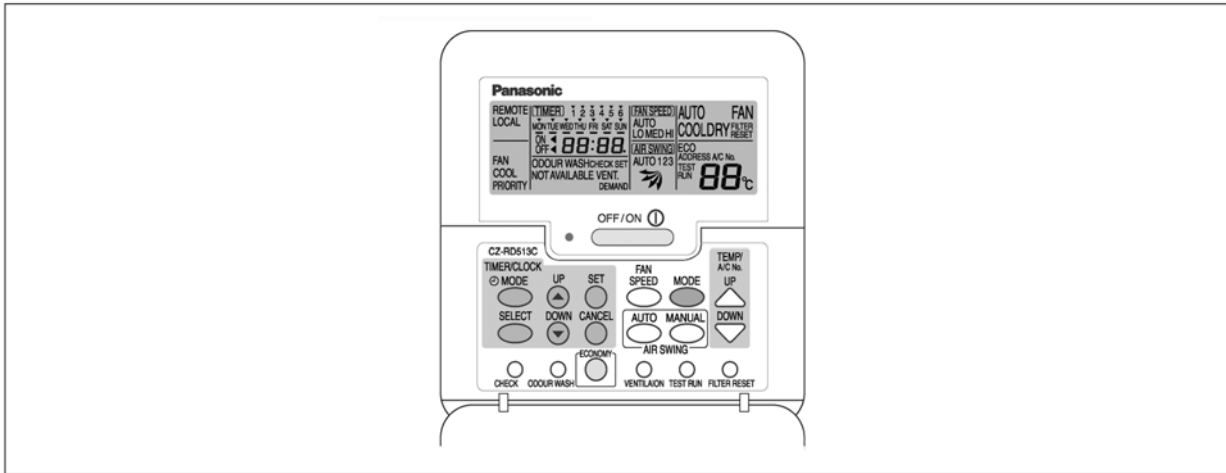

## 2.4. Wireless Remote Control

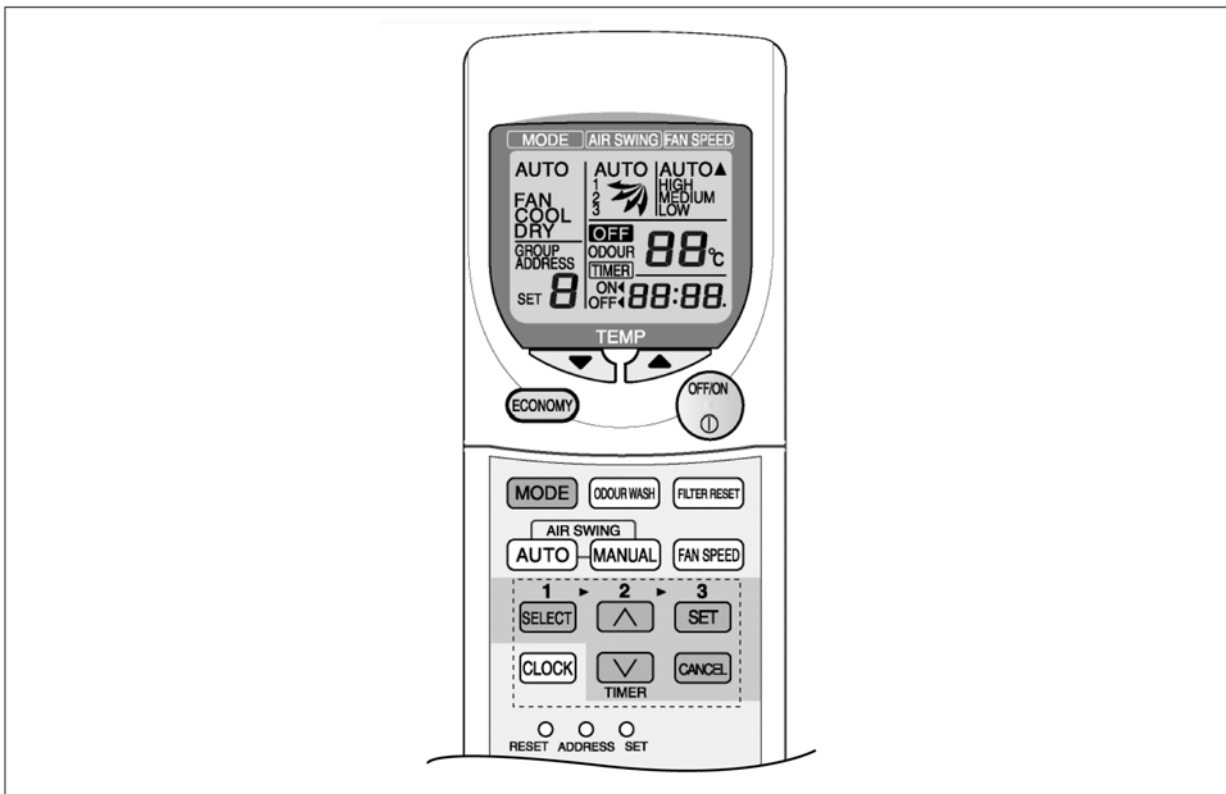

1. New design with compact size. (Operation range within approximately 8 m.)
2. Built-in timer with OFF/ON timer setting (within 24 hours)

Wired	Wireless
CZ-RD513C	CZ-RL513T

NOTE: Both of the above remote control is packed separately from the indoor unit.

## 2.5. Group Control Equipment

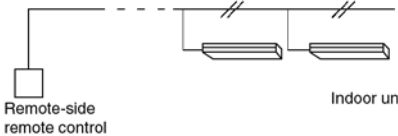
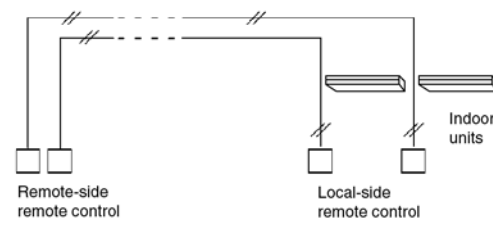
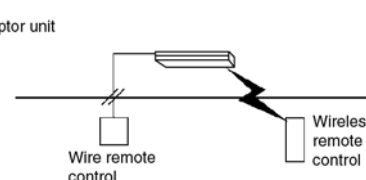
Wired remote control	<p><b>Group control by one remote control</b></p> <ul style="list-style-type: none"> <li>• All air conditioner units are controlled as a whole by remote control.</li> <li>• All indoor units operate in the same mode.</li> </ul>	 <p>Remote-side remote control</p> <p>Indoor units</p>	<p><b>[Remote side]</b></p> <ul style="list-style-type: none"> <li>• Optional wired remote control CZ-RD513C</li> </ul> <p><b>[Local side]</b></p> <p>Not needed</p>
Wired remote control	<p><b>Twin remote control separate control</b></p> <ul style="list-style-type: none"> <li>• Each indoor unit can be operated by either one of the two remote control.</li> <li>• Apart from timer setting time, displays for two remote control are identical.</li> <li>• Last button pressed has priority (main or slave is set at remote control unit).</li> </ul>	 <p>Remote-side remote control</p> <p>Local-side remote control</p> <p>Indoor units</p>	<p><b>[Remote side]</b></p> <ul style="list-style-type: none"> <li>• Optional wired remote control</li> </ul> <p><b>[Local side]</b></p> <ul style="list-style-type: none"> <li>• Optional wired remote control CZ-RD513C</li> </ul>
Common control	<p><b>Common control / group</b></p> <ul style="list-style-type: none"> <li>• Operation is possible using either wired or wireless remote control unit.</li> <li>• Last button pressed has priority.</li> </ul>	 <p>Receptor unit</p> <p>Wire remote control</p> <p>Wireless remote control</p>	<ul style="list-style-type: none"> <li>• Optional wired remote control and wireless remote control</li> </ul> <p>Wired CZ-RD513C</p> <p>Wireless CZ-RL513T</p>



# 3 Product Specification

## 3.1. CS-F18DTE5 CU-J18DBE5

ITEM / MODEL			Indoor Unit		Outdoor Unit	
			Main Body	CS-F18DTE5	CU-J18DBE5	
Cooling Capacity			Remote Control	CZ-RD513C (Wired)		
				CZ-RL513T (Wireless)		
			kW	5.0		
			BTU/h	17,100		
Refrigerant Charge-less			m	20		
Standard Air Volume for High Speed			m <sup>3</sup> /min	14	57	
			cfm	494	2013	
Outside Dimension (H × W × D)			mm	210 × 1245 × 700	795 × 900 × 320	
			inch	8-9/32 × 49-1/64 × 27-9/16	31-5/16 × 35-7/16 × 12-19/32	
Net Weight			kg (lbs)	33 (73)	57 (126)	
Piping Connection	Refrigerant	Gas	mm (inch)	O.D Ø 12.70 (1/2) Flared Type		
		Liquid	mm (inch)	O.D Ø 6.35 (1/4) Flared Type		
	Drain			O.D Ø 20	I.D Ø 20	
Compressor	Type, Number of Set			—		
	Starting Method			—		
	Motor	Type		—		
		Rated Output	kW	—		
				Hermetic, 1		
				Permanent Split Capacitor		
				2-pole 1 phase brushless motor		
				1.5		
Fan	Type, Number of Set			Sirocco fan-4		Mix flow fan-1
	Motor	Type		4-pole single phase induction motor		6-pole single phase induction motor
		Rated Output	kW	0.022		0.07
Air-heat Exchanger (Row × Stage × FPI)				Louver-fin type (2 × 12 × 18)		Corrugate-fin type (1 × 36 × 21)
Refrigerant Control				—		
Refrigerant Oil (Charged)			cm <sup>3</sup>	—		
Refrigerant (Charged) R410A			kg (oz)	—		
Running Adjustment	Control Switch			Wireless or Wired Remote Control		—
	Room Temperature			Thermostat		—
Noise Level			dB (A)	Cooling: 41/37		49/-
			Power level dB	Cooling: 58/54		65/-
Moisture Removal			L/h (Pt/h)	2.8 (5.9)		
EER			W/W	2.81/2.76/2.72		

- Cooling capacities are based on indoor temperature of 27°C D.B. (80.6°F D.B.), 19.0°C W.B. (66.2°F W.B.) and outdoor air temperature of 35°C D.B. (95°F D.B.), 24°C W.B. (75.2°F W.B.)
- Heating capacities are based on indoor temperature of 20°C D.B. (68°F D.B.) and outdoor air temperature of 7°C D.B. (44.6°F D.B.), 6°C W.B. (42.8°F W.B.)

### ELECTRICAL DATA (50 Hz)

ITEM / MODEL			Condition by ISO5151		
Volts	V		220	230	240
Phase			Single	Single	Single
Power Consumption	kW	Cooling	1.78	1.81	1.84
Running Current	A	Cooling	8.15	8.10	8.05
Starting Current	A		26	27	28
Power Factor	%	Cooling	99	97	95
*Power Factor means total figure of compressor, indoor fan motor and outdoor fan motor.					
Panasonic	Power source		AC, 1~220V, 230V, 240V 50Hz		

## 3.2. Safety Devices

### INDOOR UNIT

Indoor Unit	Cooling Only Model		CS-F18DTE5
For fan motor protection			
Internal Protector	OFF	°C	135
	ON	°C	87
For control protection			
Fuse	CUT	A	3.15

### OUTDOOR UNIT

Outdoor Unit	Cooling Only Model	50Hz	CU-J18DBE5
For refrigerant cycle			
High pressure Switch (63H1)	OFF	✕ MPa	4.15
	ON	✕ MPa	3.05
For compressor			
Over current protection			
	Cooling Only Model	OFF	A
		RESET	—
			Automatic
Discharge temp protection			
Discharge temperature thermistor (Th1)	Compressor OFF	°C	114
Liquid compress protection			
Crankcase heater	Input Power	W	37 × 2
Compressor protection			
Internal protector	OFF	°C	160
	ON	50Hz	90
	Trip Time	50Hz	3-10sec/35A
For fan motor protection			
Internal Protector (49F)	OFF	°C	135
	ON	°C	85
Heating control (Heat pump only)			
Pressure switch (Fan speed) (63H2)	OFF	✕ MPa	—
	ON	✕ MPa	—
Cooling control			
Heat exchanger temperature thermistor (Th2)	Control Method	Th ≥ 40°C —— High speed Th < 40°C —— 5 speed step control	
For control protection			
Fuse	CUT	A	6.3

(✕1) 1MPa=10.2kgf/cm<sup>2</sup>

# 4 Dimensions

## 4.1. CS-F18DTE5

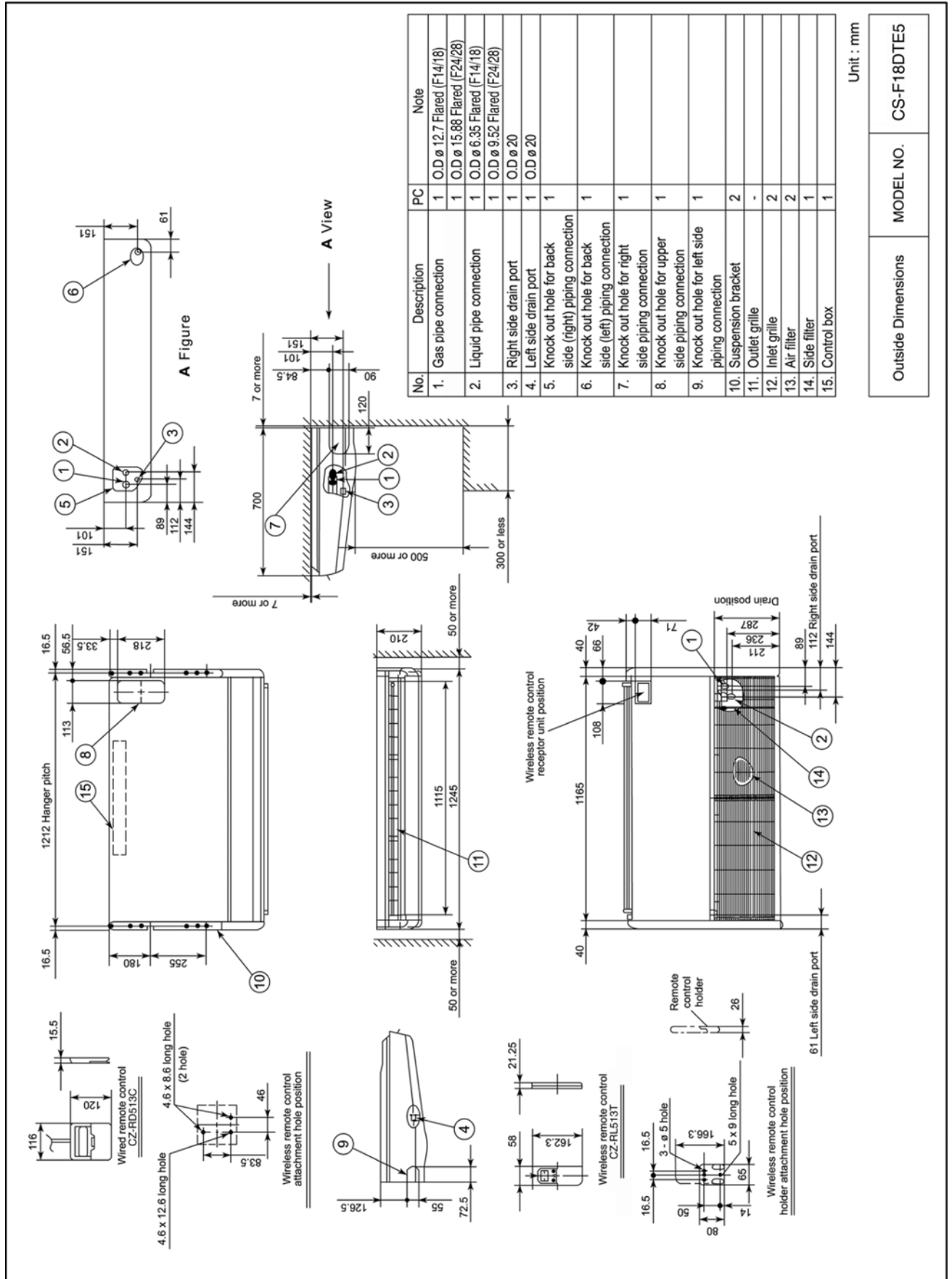

Outside Dimensions	MODEL NO.	CS-F18DTE5
--------------------	-----------	------------

## 4.2. CU-J18DBE5

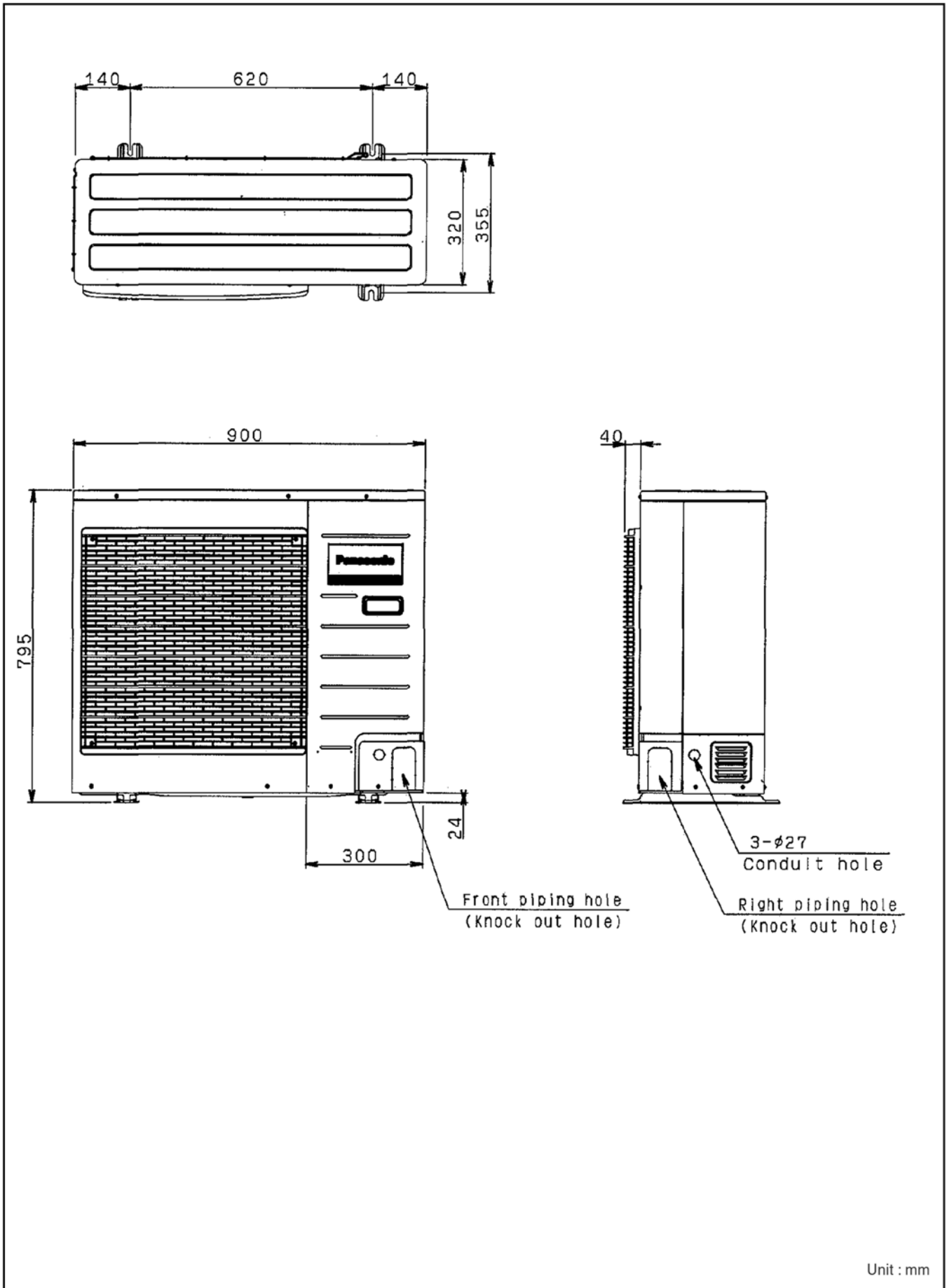

# 5 Refrigeration Cycle

## 5.1. CS-F18DTE5 CU-J18DBE5

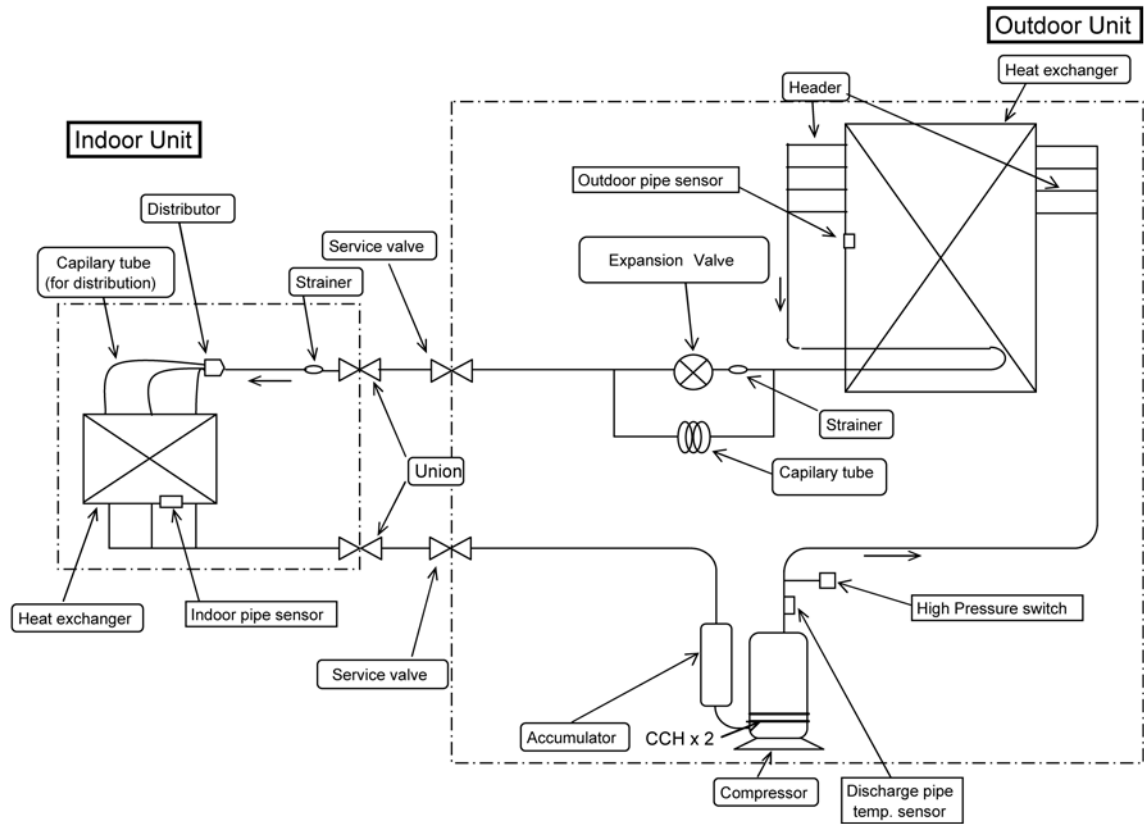

## 6 Block Diagram

### 6.1. CS-F18DTE5

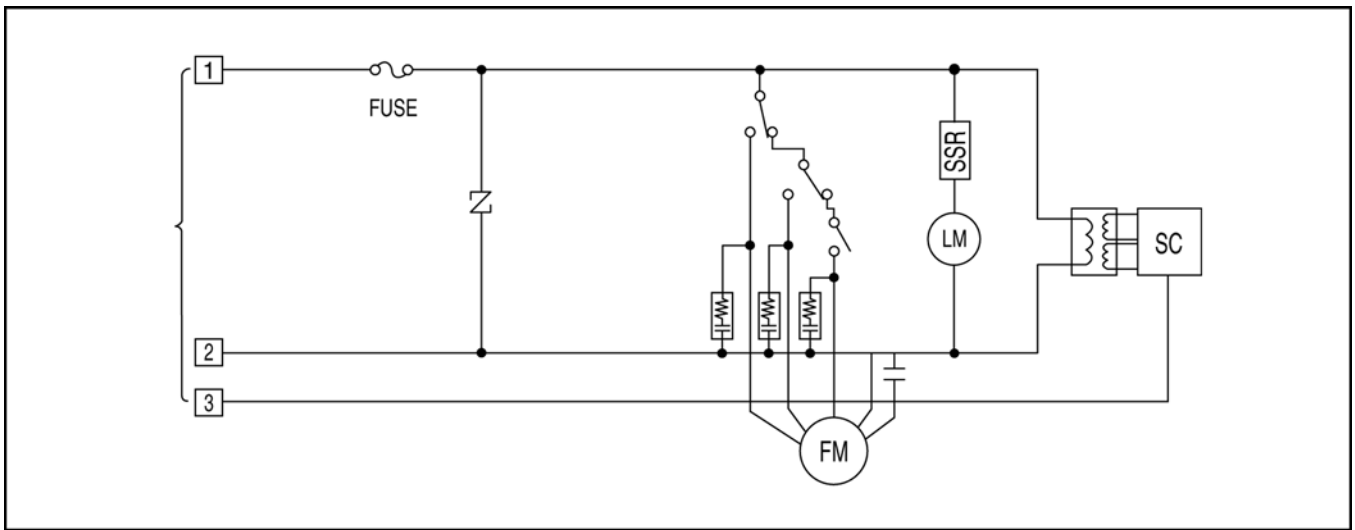

### 6.2. CU-J18DBE5

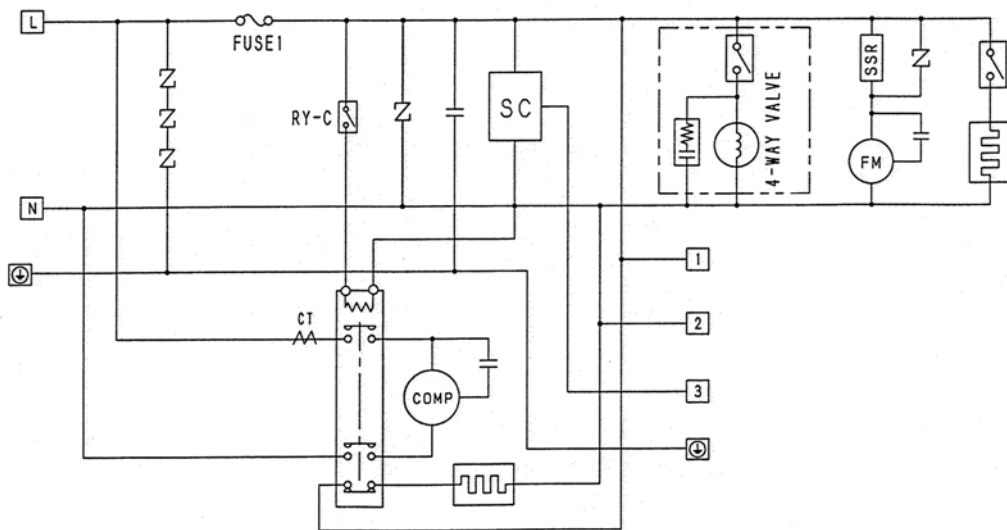

# 7 Wiring Diagram

## 7.1. CS-F18DTE5

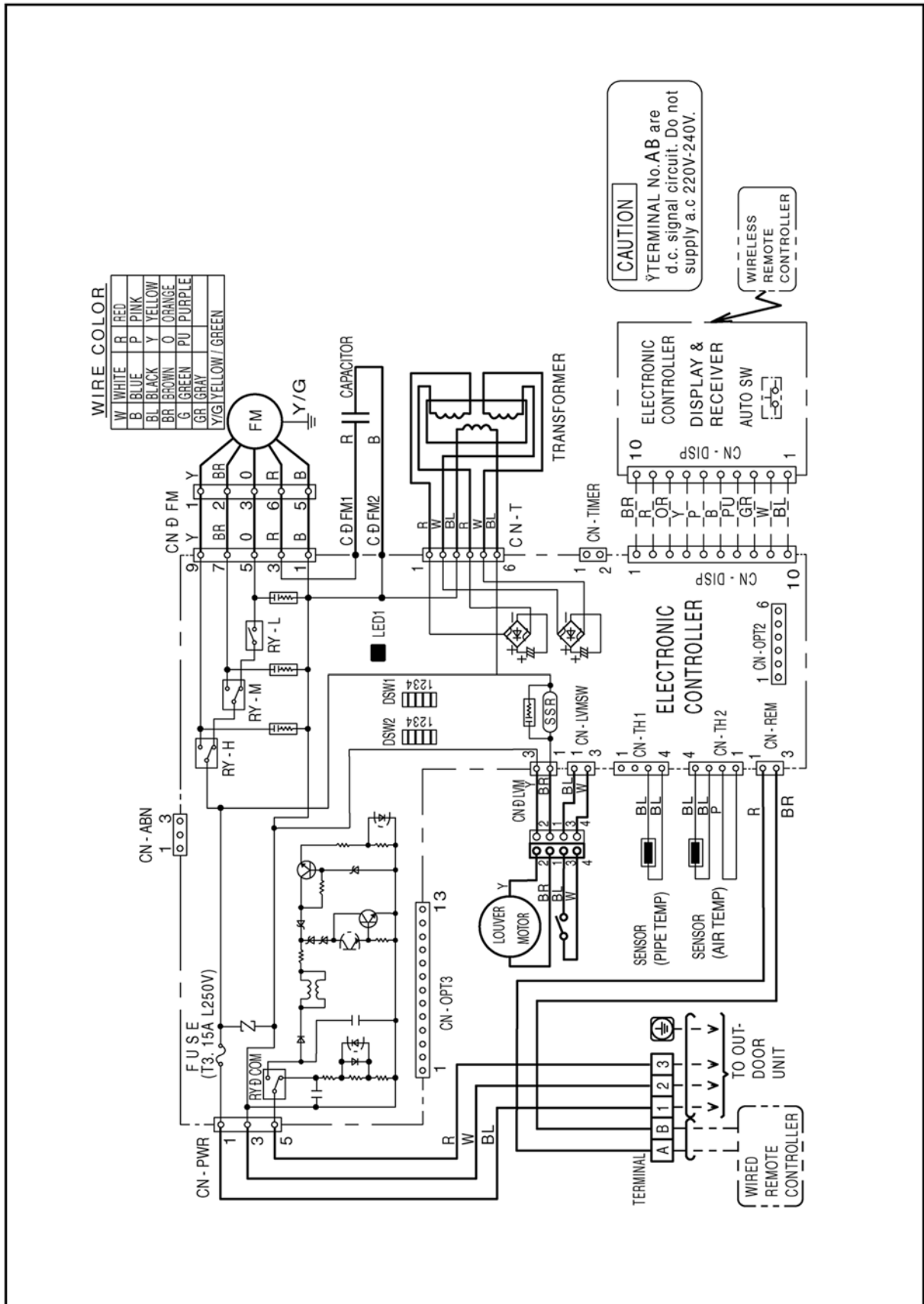

7.2. CU-J18DBE5

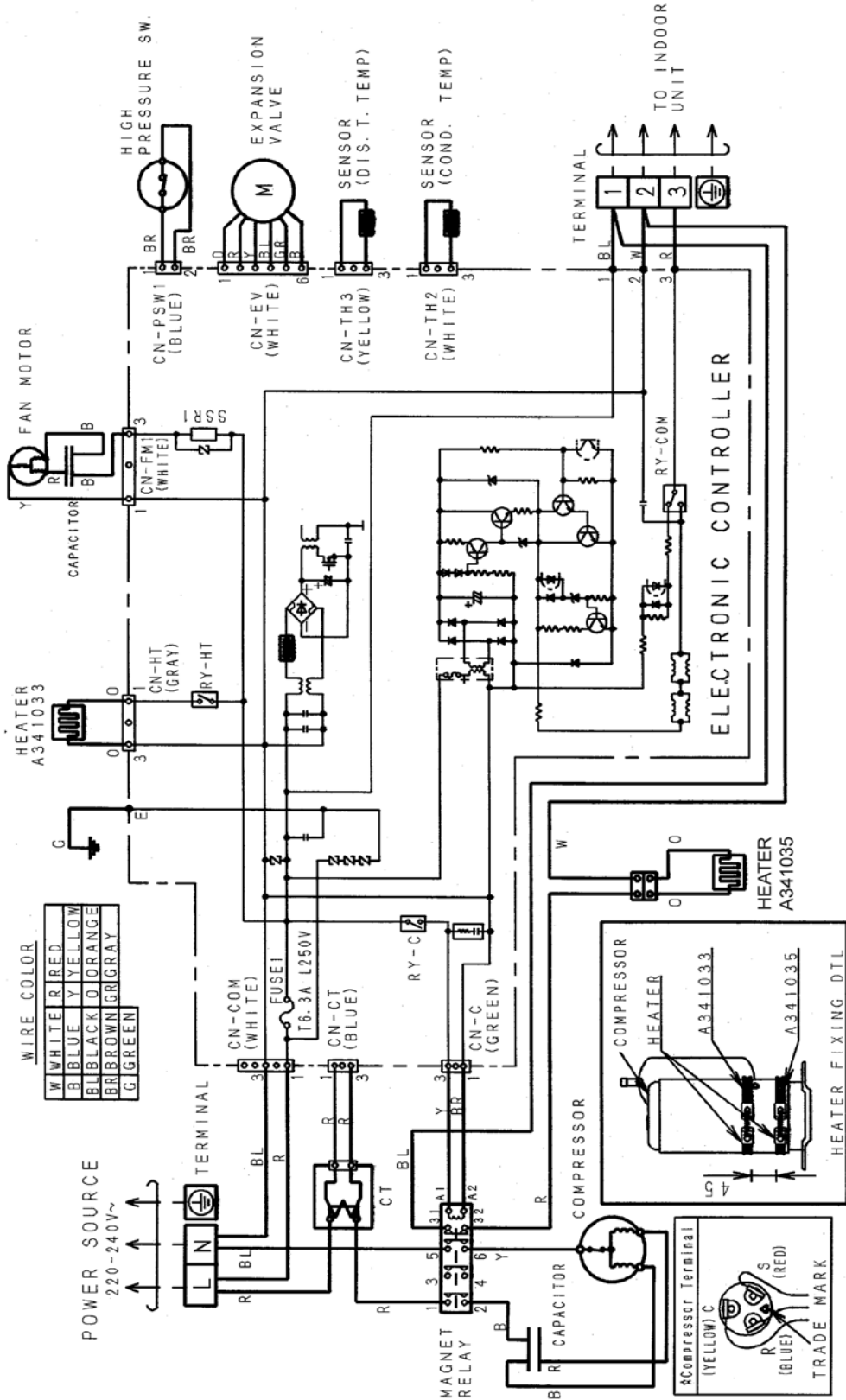



# 8 Operation Instructions

## 8.1. Wired Remote Control

Name and function of each part

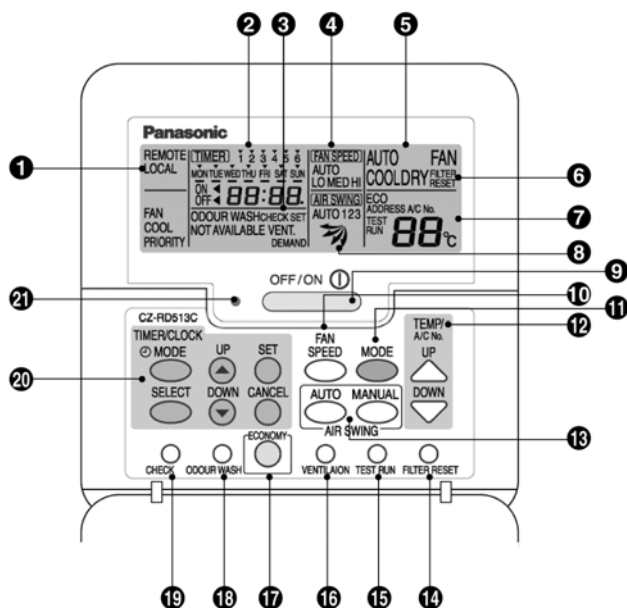

- 8 **Airflow direction setting display**
- 9 **OFF/ON button**  
Used to start and stop the operation.
- 10 **FAN SPEED button**  
Used to select the fan speed of high (HI), medium (MED), low (LO) or auto (AUTO).
- 11 **MODE button**  
Used to select the operation of AUTO, FAN, COOL, or DRY.
- 12 **TEMP (UP/DOWN) buttons**  
Used to select the desired temperature.
- 13 **AIR SWING (AUTO/MANUAL) buttons**  
Used to determine the air swing condition, either auto or manual.
- 14 **FILTER RESET button**  
Press to reset the "FILTER RESET" display after washing the filter.
- 15 **TEST RUN button\***
- 16 **VENTILATION button\***
- 17 **ECONOMY operation button**  
Provides Energy saving function
- 18 **ODOUR WASH button**  
Provides deodorizing function.
- 19 **CHECK button**  
Press this button if the check display is flashing.
- 20 **TIMER/CLOCK SET buttons**  
Used to set the timer operation and the current time.
- 21 **Operation indicator**  
Lights up when the unit in operation.

- 1 **REMOTE LOCAL**  
The OFF/ON button cannot be used.  
All wired remote control buttons can be used.

- 2 **Time/time setting display**
- 3 **Check display**
- 4 **Fan speed display**
- 5 **Operation mode selection display**
- 6 **FILTER RESET display**  
(Appears after the cumulative running time reaches approximately 2,500 hours of operation.)
- 7 **Temperature setting display (16°C - 31°C)**

### NOTES

- Ensure that the correct button is pressed as simultaneous pressing of the multiple buttons will not make the setting correct.
- The illustration above is for explanatory purposes only. The appearance will be different during actual operation.
- Do not operate the remote control with wet hands. Otherwise, electric shock or malfunction may occur.
- Do not press the remote control buttons with sharp object as this may damage the remote control.
- Buttons marked with \* are not needed for normal operation. If one of these buttons is pressed by mistake, press the same button once more to cancel the operation.
- When the power resumed after power failure, the unit will restart automatically with all the previous settings preserved by the memory function. (Auto restart function)

## 8.2. Remote Control - Display

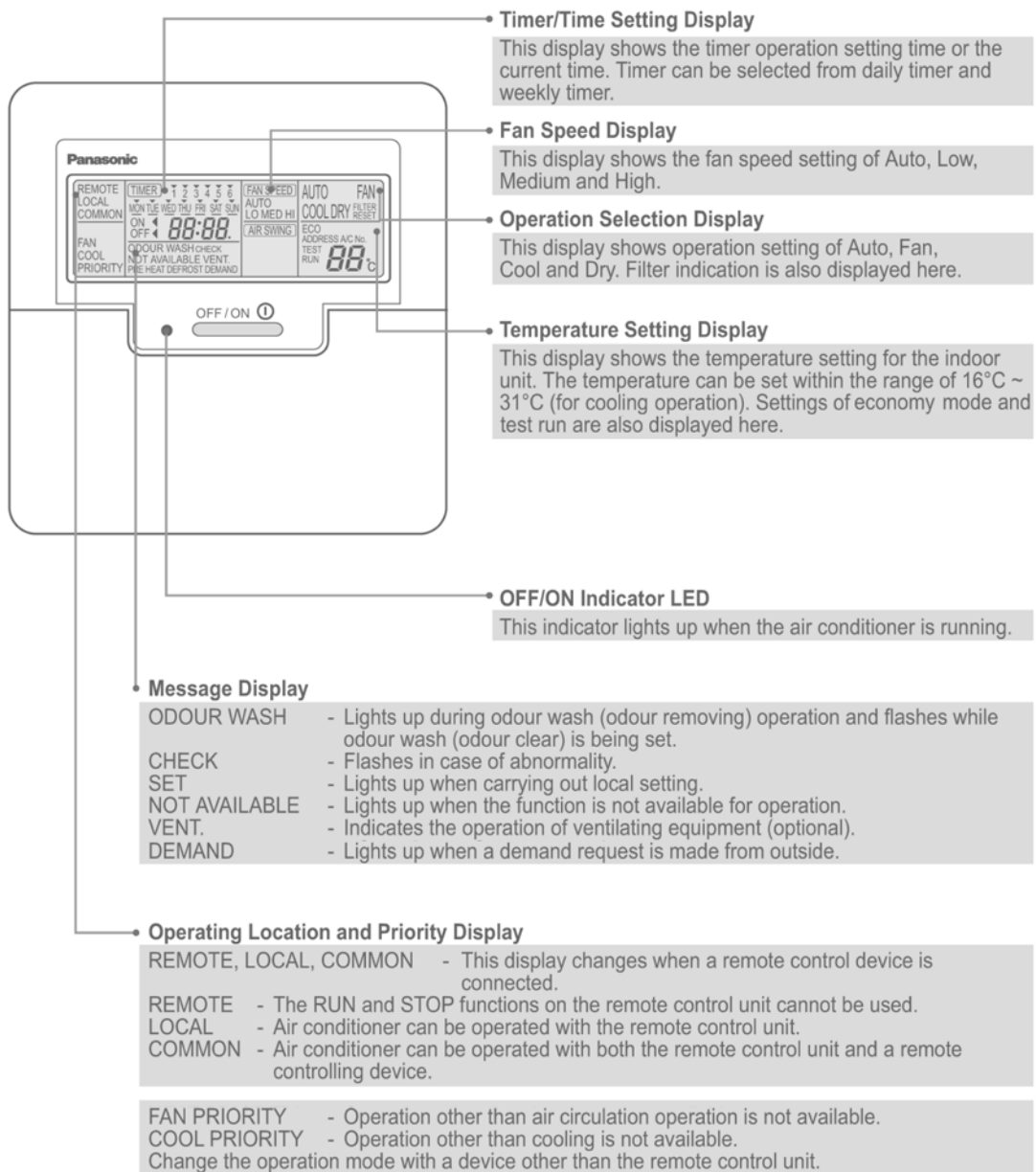

## 8.3. Remote Control - Panel

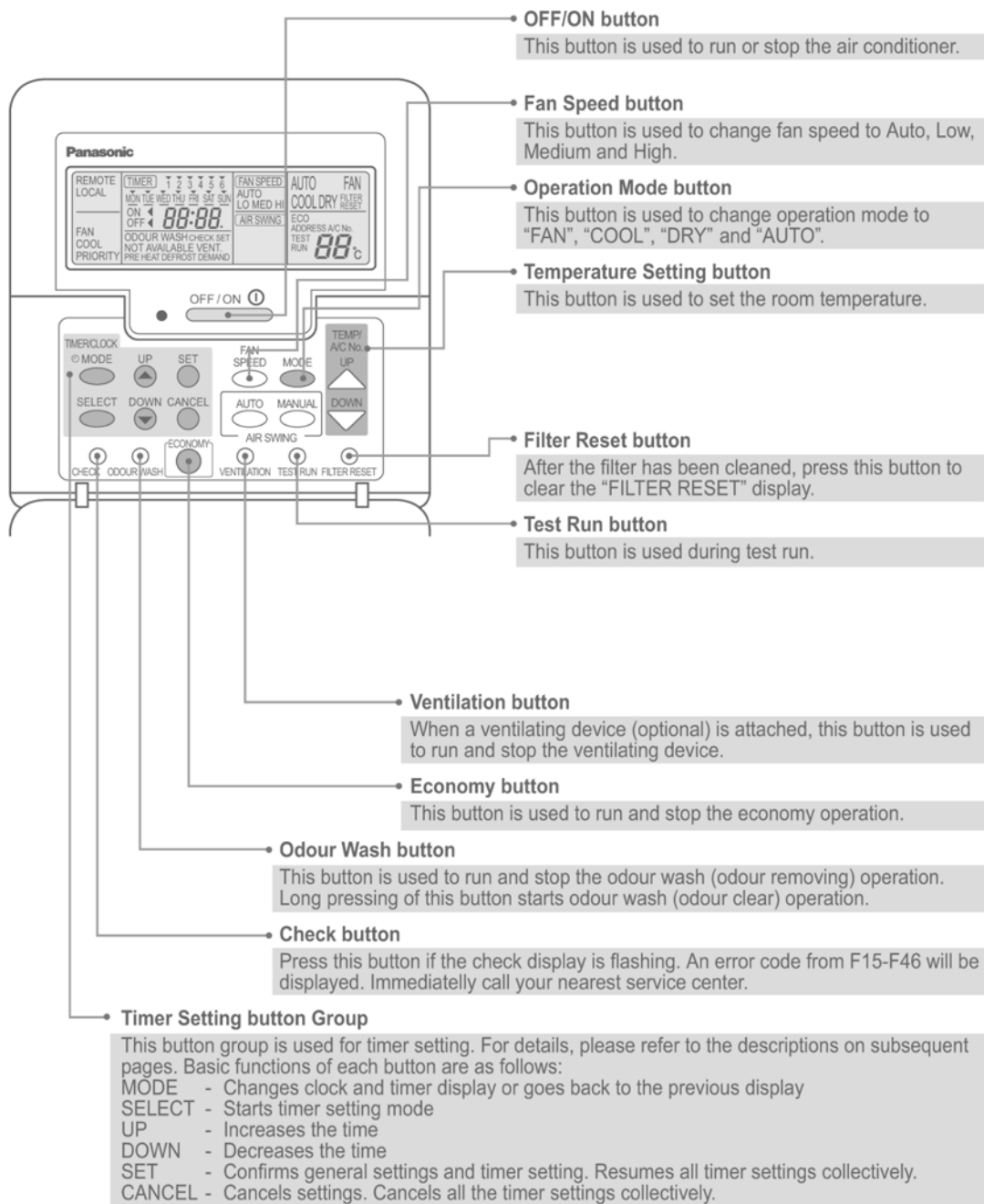

## 8.4. How to set remote control day and time

- The day and time needs to be set when you turn on the power for the first time or after a long time has elapsed since the power was last turned on.
- The day and time becomes the standard time for all the Timer operations.
- Set the day and time accurately.
- Example : Current Day is Wednesday and Current Time is 8:00.

**1** Turn on the power supply

**2** Press "SELECT button"

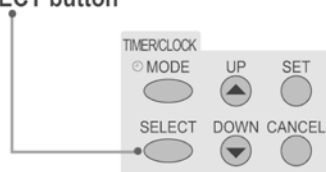

Below displays will appear

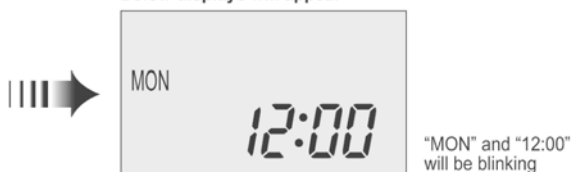

**3** Select Current Day

To set the current day, press "UP or DOWN button" to select current day.  
(Refer to above example; select WED)  
To confirm the selected day, press "SET button".

**4** Select Current Time

To set the current time, press "UP or DOWN button" to select current time.  
(Refer to above example; select 8:00)  
To confirm the selected time, press "SET button".

### Note:

- Press "UP button" to increase or "DOWN button" to decrease (interval 1 minute) or hold the button to change the time faster.
- If the "UP or DOWN button" is not pressed for 30 seconds during the day or time setting or if the "SELECT button" is pressed, the setting at that moment is confirmed and setting will end.

Final CLOCK Display

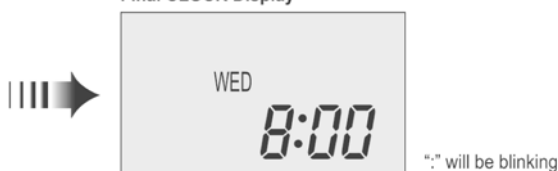

## 8.5. How To Select The Timer

- 2 types of Timer mode can be selected on the remote control.
  - Daily Timer
  - Weekly Timer
- These timers cannot be operated simultaneously.
- Select one of these Timers for your convenience.

### How to Change the Display



- Press once to change the display from CLOCK to Timer or vice-versa.
- Press more than 3 seconds to change the display from Daily Timer to Weekly Timer or vice-versa.

CLOCK Display (To set current Day and Time)

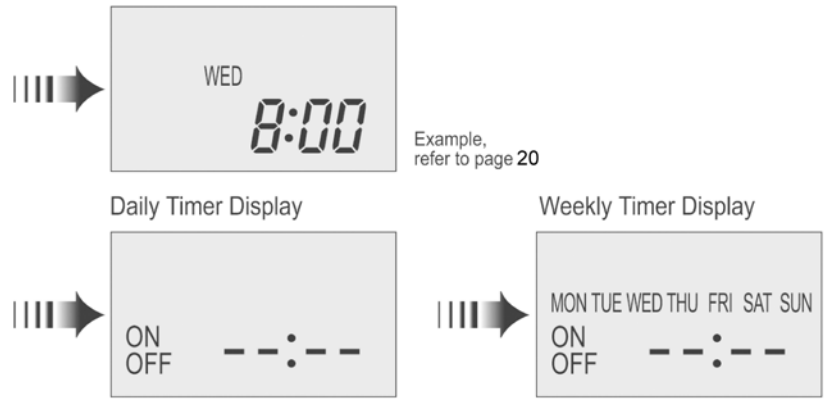

**Note:**

- The above display is shown if no valid timer setting is made.
- If valid timer setting is made.
  - **Timer** and setting will be displayed.
  - If you want to check the current time and day, press “MODE button” once.  
(However, after a few seconds, the display will change back to **Timer** and the setting)

**8.6. Daily Timer Setting**

• Display

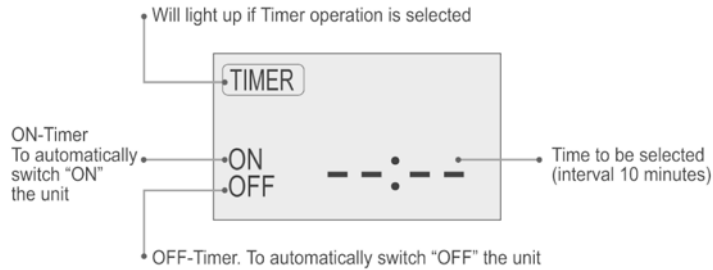

• **How to Set Daily Timer**

- You can set only “ON” or only “OFF” or “ON” and “OFF” in a day.

1. **Change Display**

Press “MODE button” to change the display to daily timer.



2. **ON-Timer, OFF-Timer and select Time**

Press “SELECT button”; ON-Timer setting will be displayed.

Press “UP or DOWN button” to select the desired time, (Example: ON 9:00), then press “SET button” to confirm the selected desired time.

Or press “CANCEL button” if you do not want any setting for ON-Timer.

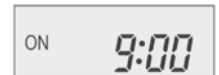

Then OFF-Timer setting will be displayed.

Press “UP or DOWN button” to select the desired time, (Example: OFF 18:30), then press “SET button” to confirm the selected desired time.

Or press “CANCEL button” if you do not want any setting for ON-Timer.

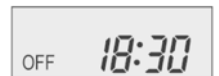

**Note:**

- The setting timer will be activated everyday.
- Timer nearer to the current time will be activated first.

Final Display of Daily Timer:



## 8.7. Weekly Timer Setting

### • Display

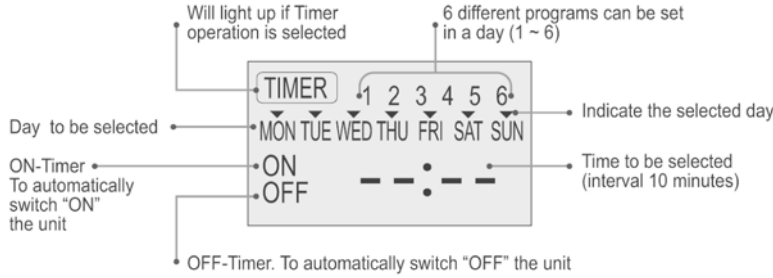

### • How to Set Weekly Timer

- You can set the Timer for 1 week (Monday to Sunday) with 6 programs per day.
- ON-Timer can be set together with your desired temperature. However, this temperature will be used continuously.
- Cannot set 2 programs with same time setting in a day.
- You also may select Collective - many days with same time setting or Individual - single/one day setting.

#### 1. Change Display

Press "MODE button" to change the display to weekly timer.

#### 2. Select Day (please refer to next page for example of setting)

You may select Collective or Individual day setting.

##### • Collective day setting.

Press "SELECT button": display will show day selection setting.

Press "UP or DOWN button" to select the day. Then press "SET button" to delete triangle mark (deselect) or add triangle mark (select).

(Triangle mark on top of each day indicates the day to be selected).

Repeat these steps if you want to deselect or select many days.

To confirm the selected days, press the "SELECT button".

##### • Individual day setting.

Press "UP or DOWN button" to select the day.

Then press "SELECT button".

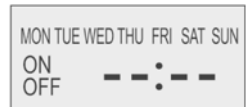
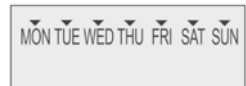

#### 3. Select Time (please refer to next page for example of setting)

For 1st program setting.

Press "UP or DOWN button" to select ON or OFF.

Then press "SET button" to confirm.

Press "UP or DOWN button" again to select the desired time.

(If you want to set them together with your desired temperature, press "TEMP UP/DOWN button" to select the temperature).

Then press "SET button" to confirm.

Or press "CANCEL button" if you do not want to set any time.

For 2nd ~ 6th program you may refer to the above step.

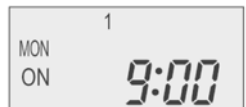

Example:  
Setting 1st program



**For example , if you want to set:**

- A - Monday to Friday: Same time, 1st program ON 9:00 & 2nd program OFF 16:00.
- B - Only Wednesday: Additional 3rd program OFF 12:30 & 4th program ON 13:30.
- C - Only Saturday: 1st program ON 10:00 with 20°C & 2nd program OFF 14:00.
- D - Sunday: Holiday. No need to set any Timer.

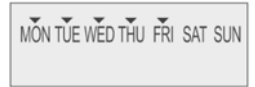

- To set A (Monday to Friday - Collective day setting)
  - Press "SELECT button"
  - To select Monday to Friday, deselect Saturday and Sunday by pressing "UP or DOWN button" to Saturday, press "SET button" (triangle mark on top of Saturday will disappear)
  - Follow the same step to deselect Sunday.
  - Ensure triangle mark appears on top of Monday ~ Friday.
    - To confirm the selected days, press "SELECT button".
    - To set the time, please refer to step 3. Select time at page 22.
      - 1st program - select ON and desired time to 9:00.
      - 2nd program - select OFF and desired time to 16:00.
      - 3rd ~ 6th program - press "CANCEL button".



- To set B (Wednesday - Individual day setting)
  - Press "UP or DOWN button" to select WED (Wednesday).
  - Then press "SELECT button".
  - To set the time, please refer to step 3. Select time at page 22.
    - 1st program - press "SET button" twice (confirm ON and 9:00)
    - 2nd program - also press "SET button" twice. (Confirm OFF and 16:00)
    - 3rd program - select OFF and desired time to 12:30
    - 4th program - select ON and desired time to 13:30
    - 5th ~6th program - press "CANCEL button"

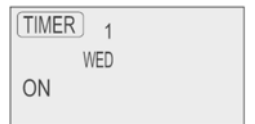

- To set C (Saturday - Individual day setting)
  - Follow the same step as above.
  - To set the time, please refer to step 3. Select time at page 22.
    - 1st program - select ON, desired time to 10:00 and desired temperature to 20°C.
    - 2nd program - select OFF and desired time to 14:00.
    - 3rd ~ 6th program - press "CANCEL button".

- Final Display for Weekly timer may show as:  
(Display is showing, 9:00 ON - Timer on Wednesday will be activated next because it is nearest the current day/time.)

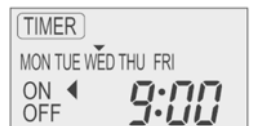

**Note:**

- Timer that has setting nearest to current time and day will be activated first.
- To check the setting timer, press "SELECT button", then "UP or DOWN button" to select day. The display will show each program for the selected day.
- To reset the setting for all, press "SELECT button", then ensure all day setting with triangle mark. Then press "CANCEL button" for all the programs.

## 8.8. Wireless Remote Control

Name and function of each part

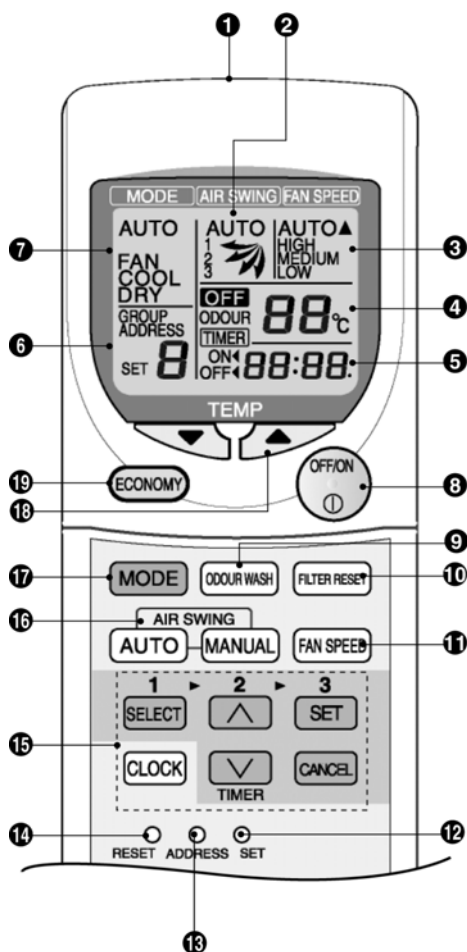

- ① Transmitter  
Transmits the remote control signal.
- ② Airflow direction setting display
- ③ Fan speed display
- ④ Temperature setting display (16°C - 31°C)
- ⑤ Time/time setting display  
Shows the timer operation setting time or the current time.
- ⑥ Address number display
- ⑦ Operation selection display
- ⑧ OFF/ON button  
Used to start and stop the operation.
- ⑨ ODOUR WASH button
- ⑩ FILTER RESET button  
Press to cancel the "FILTER" indicator light on the control panel.
- ⑪ FAN SPEED button  
Used to select the fan speed of high (HI), medium (MED), low (LO) or auto (AUTO).
- ⑫ SET button\*  
Local setting function.
- ⑬ ADDRESS SET button\*  
Used to change the address setting when using more than one indoor unit.
- ⑭ RESET button  
Pressing this button will clear all the settings from memory. You will then need to make the settings again.
- ⑮ TIMER/CLOCK SET buttons  
Used to set the timer operation and the current time.
- ⑯ AIR SWING (AUTO/MANUAL) buttons  
Used to determine the air swing condition, either auto or manual.
- ⑰ MODE button  
Used to select the operation of AUTO, FAN, COOL or DRY.
- ⑱ TEMP (UP/DOWN) buttons  
Used to select the desired temperature.
- ⑲ ECONOMY operation button

### NOTES

- Ensure that the correct button is pressed as simultaneous pressing of the multiple buttons will not make the setting correct.
- The illustration above is for explanatory purpose only. The appearance will be different during actual operation.
- If using the wireless remote control in conjunction with the wired remote control, the settings made from the wireless remote control will appear on the wired remote control display (except when making timer settings).
- Buttons marked with \* are not needed for normal operation. If one of these buttons is pressed by mistake, press the same button once more to cancel the operation.
- When the power resumed after power failure, the unit will restart automatically with all previous settings preserved by the memory function. (Auto restart function)



# 9 Operation Details

## 9.1. Cooling Operation

- Cooling operation can be set using remote control.
- This operation is applied to cool down the room temperature reaches the setting temperature set on the remote control.
- Cooling Operation Time Diagram.

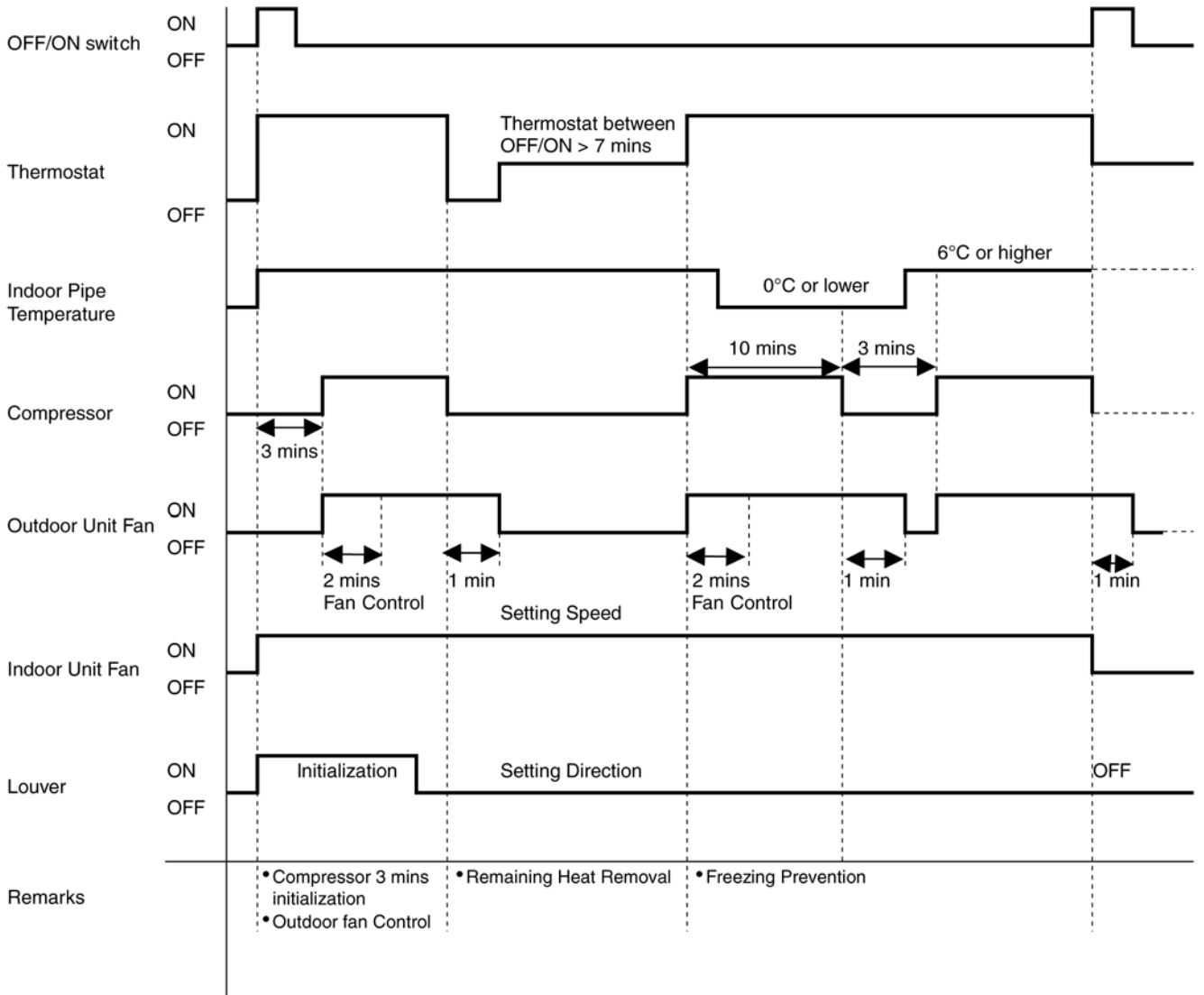

## 9.2. Soft Dry Operation

- Soft Dry Operation can be set using remote control.
- Soft Dry operation is applied to dehumidify the room.
- When operation begins, the fan speed is fixed at Low speed while cooling operation is running until reaches the remote control setting temperature.

## 9.3. Auto Operation

- Automatic Mode can be set using remote control.
- This operation starts to judge the intake air temperature, setting temperature, and outdoor piping temperature. Then the unit starts to operate at determined operation mode.

## 9.4. Fan Operation

- Fan operation can be set using remote control.
- The indoor fan is operated at High, Medium or Low speed according to remote control setting.

## 9.5. Normal Control



### 9.5.1. Cooling Indoor Fan Control

- Manual Fan Speed  
Operation starts at High, Medium or Low speed set by remote control.
- Auto Fan Speed  
When operation start, or shifting to thermostat ON condition from thermostat OFF condition, indoor fan operates as below.

Thermostat & Compressor ON/OFF		Thermostat & Compressor ON			Thermostat & Compressor OFF			Thermostat & Compressor ON		
Time		40 sec.	50 sec.	-	20 sec.	120 sec.	20 sec.	40 sec.	50 sec.	-
Cooling	Auto	Off	Lo	Hi	Lo	Off	Lo	Off	Lo	Me
Soft Dry	Auto	Off	Lo	Lo	Lo	Off	Lo	Off	Lo	Lo

### 9.5.2. Louver control

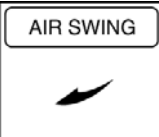
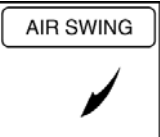
- When power is on, at the same time, louver initialize 2 times.
- During operation, stopping, thermostat is off condition, louver angle change as below table by manual setting or auto setting of remote controller.

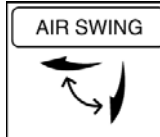
Remote controller setting		Manual				Auto		
Operation mode	Display							
		Set 1	Set 2	Set 3	Set 4	Piping temp (heating)		
Cooling (fan)	Fan	20°	35°	50°	70°	20° - 70°		
	Normal	20°	35°	50°	70°	20° - 70°		
	Dew control	35°						
	Thermostat off	20°	35°	50°	70°	20° - 70°		
Soft Dry	Normal	35°						
	Dew control	35°						
	Thermostat off	20°	35°	50°	70°	20° - 70°		
Operation mode judge		20°	35°	50°	70°	20°		
Stop mode		70°						

### 9.5.3. Cooling Outdoor Fan Control

- During cooling operation, outdoor fan speed changes according to outdoor pipe temperature.
- The fan speed is controlled by the timing of turning the outdoor fan ON and OFF within an interval.
- When outdoor pipe temperature increase, interval timing increased.
- Outdoor fan ON time is a variable with the range of 200ms to 2000ms.
- After 2 minutes, the outdoor pipe temperature is detected and the outdoor unit fan speed is changed automatically.

## 9.6. Operation Control

### 9.6.1. Odour Cut Control

- Odour cut operation removes the odour generated at indoor heat exchanger by using drain water come out from indoor heat exchanger.
- Press "Odour" button at remote control to enable odour cut operation.
- Odour cut operation starts when compressor or thermostat is on.

Thermostat & Compressor ON/OFF	Thermostat & Compressor ON			Thermostat & Compressor OFF			Thermostat & Compressor ON		
	Time	40 sec.	50 sec.	-	20 sec.	120 sec.	20 sec.	40 sec.	50 sec.
Cooling	Off	Lo	Normal Operation	Lo	Off	Lo	Off	Lo	Normal Operation
Soft Dry	Off	Lo	Lo	Lo	Off	Lo	Off	Lo	Lo

### 9.6.2. Energy Saving

- During Operation, press "Economy" button at remote control to enable Energy Saving Operation.
- The air conditioner judges the stable condition, where the different between indoor suction temperature and setting temperature is 1°C for 30 minutes and moderately shifts the set temperature in 0.5°C steps (Maximum 2°C) to control energy saving operation.
- If temperature different is out of range, energy save operation will not start.
- Energy Save Operation is canceled by pressing the "Economy" button again.

Energy save control time chart

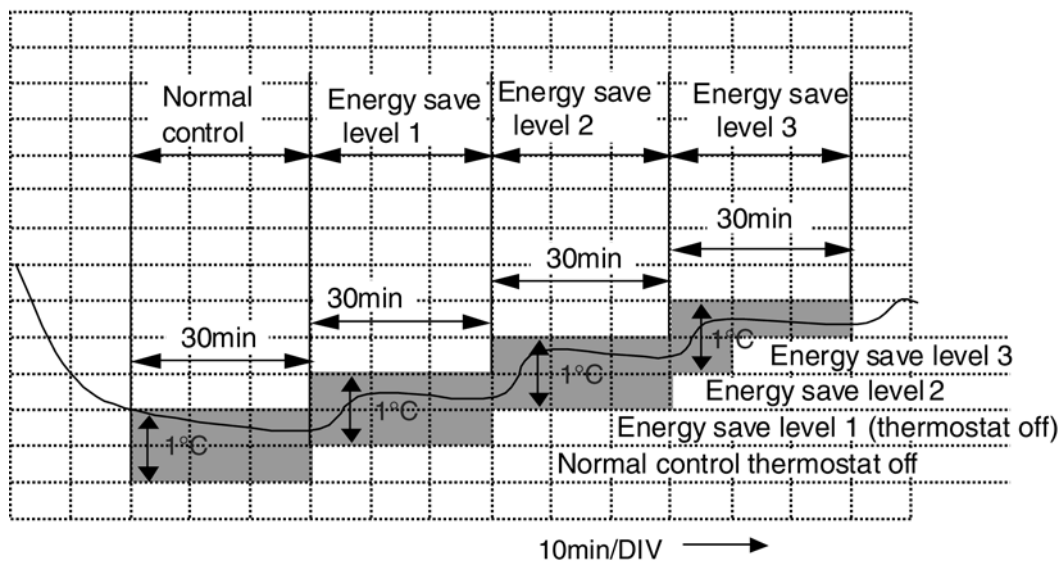

### 9.6.3. Dew Form Prevention Control

- During Cooling or Soft Dry operation, if outdoor temperature is less than 30°C, and indoor fan speed is low or auto setting, indoor heat exchanger temperature become lower, dew form prevention control start to prevention dew form at indoor discharge grille.
- When indoor pipe temperature decrease, the cooling capacity will be reduced and the louver angle will be fixed at certain angle.

### 9.6.4. Freeze Prevention Control

- After compressor starts operation for 4 minutes, the outdoor unit will stop its operation if indoor pipe temperature falls below 0°C for 6 minutes.
- After 3 minutes stops, compressor restarts operation if indoor pipe temperature is 6°C or more.
- This phenomenon is to protect the indoor heat exchanger from freezing and to prevent higher volume of refrigerant in liquid from returning to the compressor.

### 9.6.5. Time Delay Safe Control

- The compressor will not start for three minutes after stop of operation.

### 9.6.6. Outdoor Fan Remaining Heat Removal Control

- When compressor stop, outdoor fan operates at High speed for 1 minute to remove the remaining heat.

### 9.6.7. Thermostat Control

- Depending on differences between room temperature and setting temperature, compressor operation is decided and starts operation.
- If temperature difference matches values shown below, thermostat switches off.

Cooling Mode	-1.5°C
Soft Dry Mode	-2.5°C

## 9.7. Protection Control

### 9.7.1. Outdoor Low-pressure Protection Control

- The purpose of low-pressure protection control is gas leakage detection control.
- The low-pressure protection control starts when low-pressure switch is activated less than 15 minutes after compressor startup.
- During this protection control, compressor is shut down, indoor unit is set to thermo-off status.
- After 6 occasions, suction pressure error is displayed; all operation stopped except outdoor fan remaining heat removal control.

### 9.7.2. Outdoor High-pressure Protection Control

- The high-pressure protection control starts when high-pressure switch is activated less than 15 minutes after compressor startup.
- During this protection control, compressor is shut down. And indoor unit is set to thermo-off status.
- After 6 occasions, high-pressure protection error is displayed; all operation stopped except outdoor fan remaining heat removal control.

### 9.7.3. Discharge Temperature Protection Control

- The discharge temperature protection control starts when abnormal compressor temperature 115°C is detected when outdoor unit is operating in cooling operation.
- During this protection control, compressor is shut down. And indoor unit is set to thermo-off status.
- After 6 occasions, high-pressure protection error is displayed; all operation stopped except outdoor fan remaining heat removal control.

### 9.7.4. Over Current Protection Control

- The purpose of over current protection control is to protect the air conditioner from over current.
- The over current protection control starts when input current from CT is maintained at 20A or more for 2 seconds when the outdoor unit is starting up or during cooling operation.
- During this protection control, compressor is shut down. And indoor unit is set to thermo-off status.
- After 4 occasions, over current protection error is displayed; all operation stopped except outdoor fan remaining heat removal control.

### 9.7.5. CT Disconnection Detection Control

- CT disconnection detection control detects if the CT sensor works normally.
- The CT disconnection detection activates when:
  - CT input value is maintained at compressor shutdown status (1.5A or less) consecutively for 2 seconds when the compressor is operating.
    - During this condition, compressor is shut down and indoor unit is set to thermo-off status.
    - After 4 occasions, CT sensor error is displayed; all operation stopped except outdoor fan remaining heat removal control.
  - CT input value is maintained at compressor operation status (5A or more) consecutively for a period of 60 seconds when the compressor is shut down.
    - During this condition, CT sensor error is displayed.

### 9.7.6. Connection Capacity Protection Control

- The purpose of connection capacity protection control is to ensure the total capacity of connected indoor units is within acceptable range.

Model Number	Min. Capacity (kW)	Max. Capacity (kW)	Model Number	Min. Capacity (kW)	Max. Capacity (kW)
CU-J14DBE5	5.3	6.9	CU-B28DBE8	6.3	9.8
CU-J18DBE5	5.3	6.9	CU-B34DBE8	7.3	12.3
CU-J24DBE5	5.3	6.9	CU-B43DBE8	10.2	13.8
CU-J28DBE5	6.3	9.8	CU-B50DBE8	12.7	15.8
CU-J34DBE5	7.3	12.3			

- During this protection control, connection capacity error is displayed; all operations stopped.

### 9.7.7. Sensor Disconnection Detection Control

- The sensor disconnection detection control activates when the following condition comply:

Sensor	Detection Threshold	Duration (Sec.)	Detection Condition
Discharge Temperature	< -4.5°C or 201.8°C	5	Other than compressor start control and compressor ON
Outdoor Heat Exchanger	< -50.5°C or 103.7°C	5	Regularly

- During sensor disconnection, sensor error is displayed; all operations stops except outdoor fan remaining heat removal control.

### 9.7.8. High-pressure Switch Disconnection Error Detection Control

- High-pressure switch disconnection is detected when high-pressure switch input continuously open for 1 minutes while the compressor shutdown.
- During this error, high-pressure switch error is displayed.

### 9.7.9. Low-pressure Switch Disconnection Error Detection Control

- Low-pressure switch disconnection is detected when low-pressure switch input continuously open for 1 minutes while compressor shutdown.
- During this error, low-pressure switch error is displayed.

## 9.8. Test Run

- Test run is necessary after installation is completed.
- To enable forced cooling test run, at outdoor PCB, set the DS1 to position below:



- To enable forced heating test run, at outdoor PCB, set the DS1 to position below:



- Press Test Run button at outdoor pcb for 1 second.

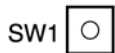

# 10 Installation Instruction

## 10.1. Pipe length

### • CORRECTION OF CAPACITIES

1. Correction of capacities according to the connecting pipe length.

The data of rated capacities (marked on the name plate) are based on 7.5 meters connecting pipe and horizontal installation.

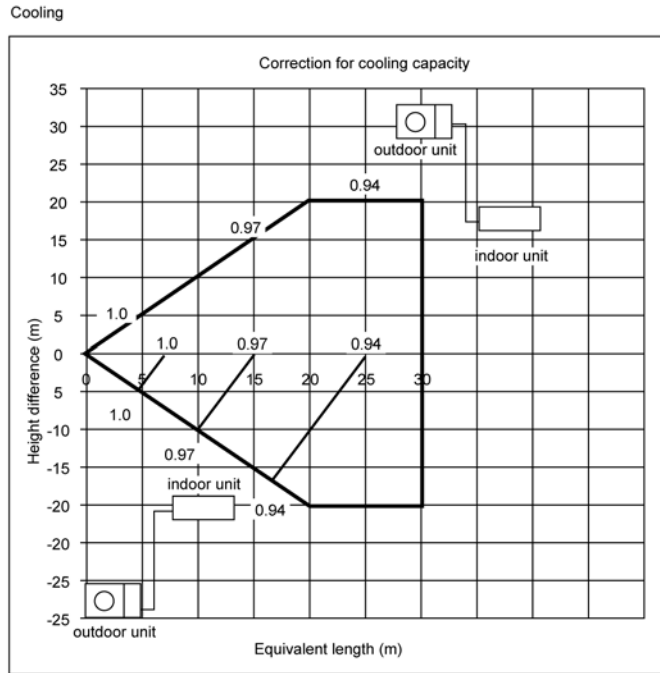

2. For other pipe length of other installation multiply by the following correction factor to determine the revised cooling capacity.

Piping Size / Length & Elevation											
		Model No.	Piping size				Piping length (A)	Piping elevation (B)	Piping elevation (C)	Piping Chargeless	Add Refrigerant
			Liquid / High	Valve	Gas / Low	Valve	Max(m)	Max(m)	Max(m)	Max(m)	(g/m)
Cassette type	R 4 1 0 A	CS-F18DTE5	6.35	3-ways	12.70	3-ways	30	20	20	20	20

#### Note :

Piping elevation B = outdoor unit installed at top

Piping elevation C = outdoor unit installed at bottom

## 10.2. Refrigerant additional charge

### 1. Piping installation by standard piping

- At the time of shipment from the factory, this unit is charged with enough refrigerant for an equivalent pipe length of 20m. (Refer the following table)

But when the piping length exceeds 20m, additional charge is required according to the following table.

#### Example:

#### CU-J18DBE5

In case of 30m long pipe (one way), the amount of refrigerant to be replenished is:  $(30 - 20) \times 20 = 200\text{g}$

Model Name	Standard piping specification			
	Liquid piping (dia.mm)	Gas piping (dia.mm)	Gas chargeless length (m)	Additional gas volume (g/m)
CU-J18DBE5	6.35	12.7	20	20

### 10.3. Position of the centre gravity

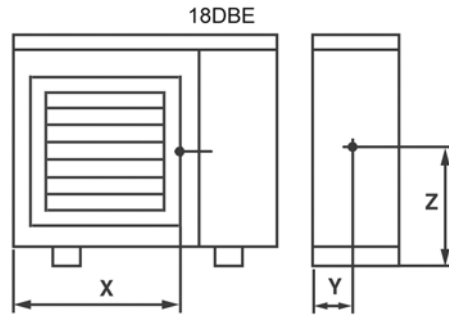

MODEL NAME	OUTSIDE DIMENSIONS			NET WEIGHT kg	CENTRE OF GRAVITY		
	WIDTH (mm)	DEPTH (mm)	HEIGHT (mm)		X (mm)	Y (mm)	Z (mm)
CU-J18DBE5	900	320	795	69	560	150	320

## 10.4. Indoor unit installation

### CEILING TYPE AIR CONDITIONERS INSTALLATION INSTRUCTIONS

**REFRIGERANT  
R410A**

HP	Model name
2 HP	CS-F18DT**
2.5 HP	CS-F24DT**
3 HP	CS-F28DT**
4 HP	CS-F34DT**
5 HP	CS-F43DT**
6 HP	CS-F50DT**

#### Precautions in terms of safety

Carry out installation work with reliability after throughout reading of this "Precautions in terms of safety".

- Precautions shown here are differentiated between ⚠ Warnings and ⚠ Cautions. Those that have much chance for leading to significant result such as fatality or serious injury if wrong installation would have been carried out are listed compiling them especially into the column of ⚠ Warnings.

However, even in the case of items which are listed in the column of ⚠ Cautions, such items also have a chance for leading to significant result depending on the situations.

In either case, important descriptions regarding the safety are listed, then observe them without fail.

- As to indications with illustration



This mark means "Caution" or "Warning".



This mark means "Earth".

- After installation work has been completed, do not only make sure that the unit is free from any abnormal condition through the execution of trial run but also explain how to use and how to perform maintenance of this unit to the customer according to the instruction manual.  
In addition, request the customer to keep this manual for installation work together with instruction manual.

#### ⚠ Warnings

<p>▲ The appliance must be installed by technician, who takes into account the requirements given by ISO5149 or eventual equivalent requirements.</p>	<p>▲ If installing inside a small room, measures should be taken to prevent refrigerant levels from building up to critical concentrations in the event of a refrigerant leak occurring. Please discuss with the place of purchase for advice on what measures may be necessary to prevent critical concentrations being exceeded. If the refrigerant leaks and reaches critical concentration levels, there is the danger that death from suffocation may result.</p>
<p>▲ As to installation, request the distributor or vendor to perform it. Imperfection in installation caused by that having been carried out by the customer himself may lead to water leakage, electric shock, fire, etc.</p>	<p>▲ Securely attach the protective covers for the outdoor unit connection cables and power cord so that they do not lift up after installation. If the covers are not properly attached and installed, the terminal connections may overheat, and fire or electric shock may result.</p>
<p>▲ Carry out the installation work with reliability according to this manual for installation work. Imperfection in installation leads to water leakage, electric shock, fire, etc.</p>	<p>▲ Switch off all supplies before accessing any electrical part.</p>
<p>▲ Carry out the installation work with reliability on the place that can bear the weight of this unit sufficiently. Insufficient strength leads to injury due to falling of the unit.</p>	<p>▲ If refrigerant gas escapes during installation, ventilate the affected area. If the refrigerant gas comes into contact with sparks or naked flames, it will cause toxic gases to be generated.</p>
<p>▲ Carry out predetermined installation work in preparation for strong wind such as typhoon, earthquake. Imperfection in installation work may lead to accidents arisen from overturn, etc.</p>	<p>▲ Once installation work is completed, check that there are no refrigerant gas in the room that can come into contact with sparks or flames from a fan heater, stove or kitchen range, which will cause toxic gases to be generated.</p>



⚠ Warnings	
<p>▲ The unit must be installed in accordance with applicable national and local regulations. Any electrical work should only be carried out by qualified technician and use exclusive circuits without fail. Presence of insufficient capacity in power circuit or imperfection in execution leads to electric shock, fire, etc.</p>	<p>▲ Earth This equipment must be properly earthed. Earth line must not be connected to earth of gas pipe, water pipe, lightning rod and telephone. Otherwise, it may cause electrical shock in case the equipment breakdown or has leakage current.</p> 
<p>▲ Wiring shall be connected using specified cables and fix them securely so that external force of the cables may not transfer to the terminal connection section. Imperfect connection and fixing leads to fire, etc.</p>	<p>▲ Installation of Earth Leakage Current Breaker This equipment must be installed with earth leakage current breaker. Otherwise, it may cause electrical shock and fire in case the equipment breakdown or has leakage current.</p>
<p>▲ When performing piping work do not mix air except for specified refrigerant (R22) in refrigeration cycle. it causes capacity down, and risk of explosion and injury due to high tension inside the refrigerant cycle.</p>	

⚠ Cautions	
<p>▲ Do not install the unit at the place where the possibility of inflammable gas leakage exists. If gas leakage should arise and the gas builds up around the unit, such situation may lead to ignition.</p>	<p>▲ Position the indoor unit and outdoor unit, power cords and indoor/outdoor unit connection cables in a way so that they are at least 1 meter away from televisions and radios. This is to avoid problem such as interference with picture and/or sound. (However, note that depending on the electromagnetic wave conditions, interference may still occur even if the separation distance is more than 1 meter.)</p>
<p>▲ Drain piping should be made to ensure secure drainage according to the manual for installation work and carry out the thermal insulation to prevent the occurrence of condensation. Imperfection in piping work lead to water leakage and may cause the house and property, etc. to become wet.</p>	

### 10.4.1. Accessories packed in the indoor unit container

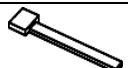
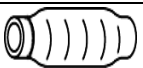
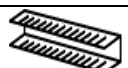
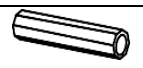
Name	Q'ty	Appearance	Purpose	Name	Q'ty	Appearance	Purpose
Band	4		For fastening the heat insulator	Drain hose	1		For drain piping
Edge protection cover	1		To protect the end surface of the piping holes	Heat insulator	2		For insulating refrigerant pipe joint

### 10.4.2. Selecting the location for indoor unit

Provide a check port on the piping side ceiling for repair and maintenance.

- Install the indoor unit once the following conditions are satisfied and after receiving the customer approval.
  1. The indoor unit must keep a maintenance space.
  2. The indoor unit must be free from any obstacles in path of the air inlet and outlet, and must allow spreading of air throughout the room.

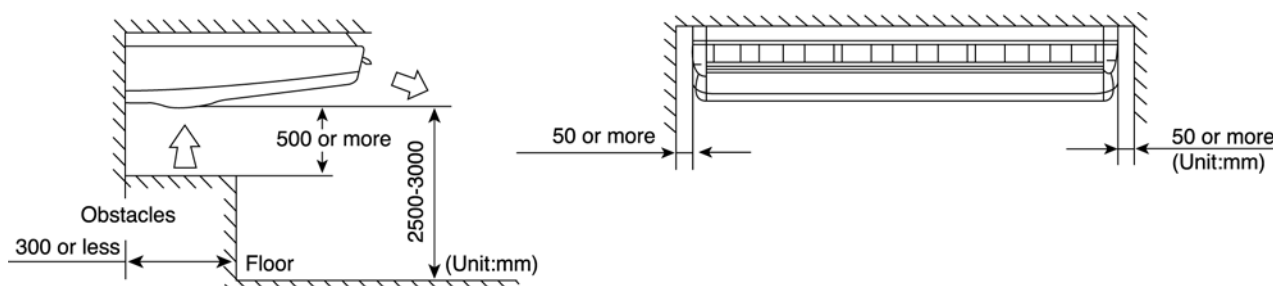

3. The installation position must be able to support a load four times the indoor unit weight. ⚠ Warnings
4. The installation location (surface that the unit is suspended from) must be horizontal (and guaranteed to stay horizontal).
5. The indoor unit must be away from heat and steam sources, but avoid installing it near an entrance.
6. The indoor unit must allow easy draining.
7. The indoor unit must allow easy connection to the outdoor unit.
8. The indoor unit must be at least 3m away from any noise-generating equipment. The electrical wiring must be shielded with a steel conduit.
9. If the power supply is subject to noise generation, add a suppressor.
10. Do not install the indoor unit at a laundry. Electric shocks may result.

**NOTE**

- Study through the following installation locations.
  1. In places such as restaurants and kitchens, considerable amount of oil steam and flour adhere to the fan, and the fin of the heat exchanger may result in heat exchange reduction, spraying or dispersing of water drops, etc.  
In these cases, take the following actions:
    - Make sure the ventilation fan for smoke-collection hood on a cooking table has sufficient capacity so that it draws oily steam which should not flow into the suction of the air conditioner.
    - Make enough distance from cooking room to install the air conditioner in such place where it may not suck in oily steam.

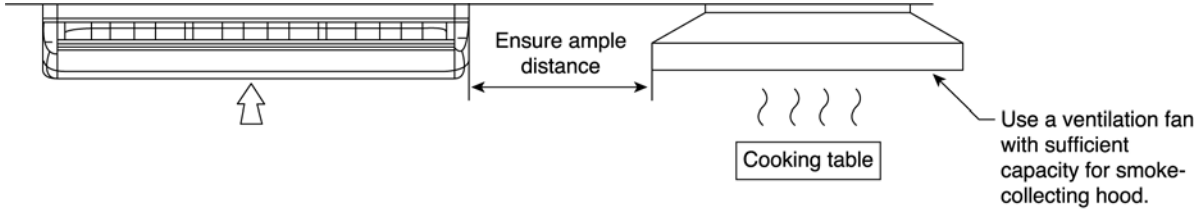

2. Avoid installing the air conditioner in such circumstances where cutting oil mist or iron powder exist especially in factories, etc.
3. Avoid places where inflammable gas can be generated, flows-in, contaminated, or leak.
4. Avoid places where sulphurous acid gas or corrosive gas can be generated.
5. Avoid places near high frequency generators.

**10.4.3. Installation of indoor unit**

The paper template for installation may expand or shrink according to temperature and humidity. Check the dimensions before using it.

**CEILING OPENING DIMENSIONS AND HANGING BOLT LOCATION**

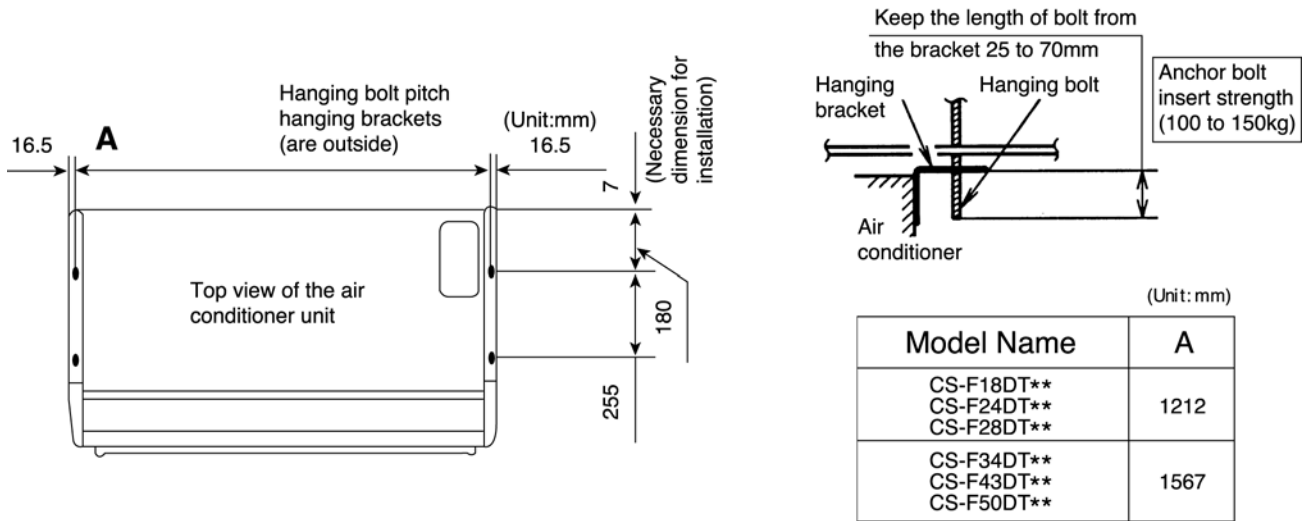

(Unit: mm)	
Model Name	A
CS-F18DT** CS-F24DT** CS-F28DT**	1212
CS-F34DT** CS-F43DT** CS-F50DT**	1567

**Caution** | During the installation, care must be taken not to damage the electric wires.

### REMOVING THE SIDE COVER AND HANGING BRACKET

1. Open the inlet grille, and remove the side cover fixing screw (right and left) from the internal part of the unit.
2. Move the side cover to about 15mm forward to remove it. Use the packing material (Styrene foam) to support, when you reverse the top and bottom of the indoor unit.
3. Remove the hanging bracket
  - a. Remove the slip prevention screws of the brackets (right and left).
  - b. Loosen the hanging bracket fastening bolts to about 10mm, and remove the hanging bracket.

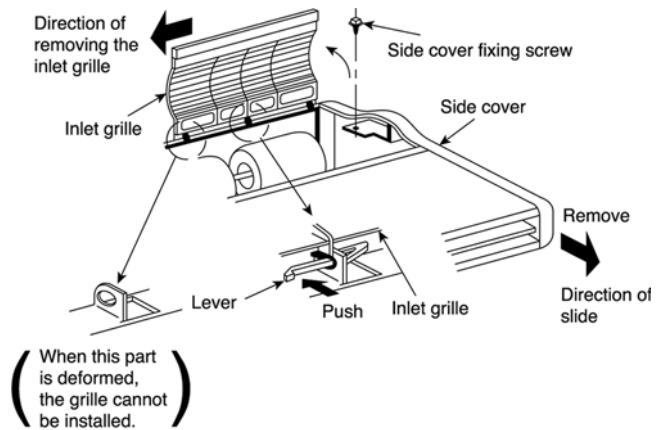

### Fastening the hanging bracket

- \* Use either W3/8 or M10 bolts and nuts (local supplied)
- Fastening the hanging bracket

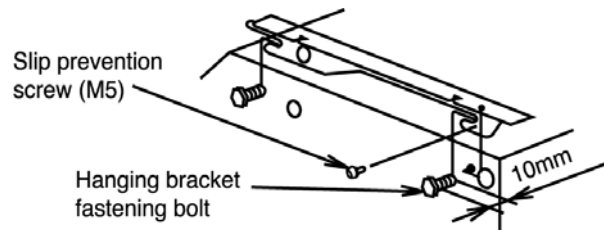
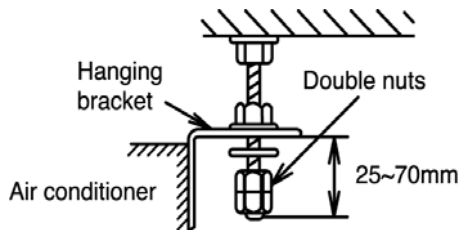

Caution : For safety, you must use washers and double nuts to ensure a secure installation.

**Warning** Be sure to tighten the nut and bolt to prevent the unit from falling.

### Piping hole positions

- The refrigerant piping can be installed on the right, right upper or right rear.
- The drain piping can be installed on the right, right rear, left or left rear (there are connection ports on both right and left sides.)
- Thermally insulate the drain and refrigerant piping to prevent dew condensation.
- After cutting the piping holes, use the edge protection cover (accessory) to protect the end surfaces.

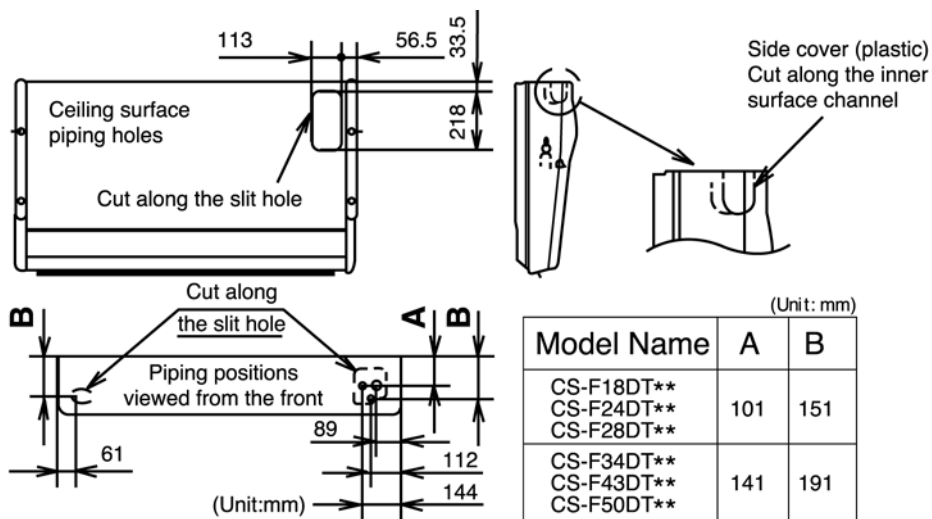

1. Insert the hanging bracket fastening bolts and both sides of the unit into the hanging brackets, and slide the unit to the rear. Fasten the bolts.
2. Tighten the slip prevention screws (M5) for brackets to prevent the unit from shifting.
3. To ensure correct drainage, after hanging the unit, use a level gauge to check the installation angle.

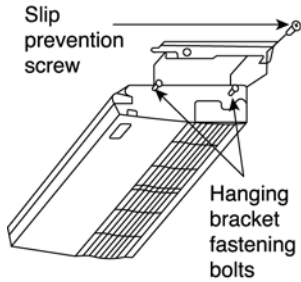

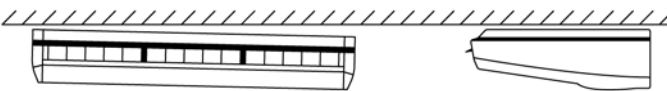
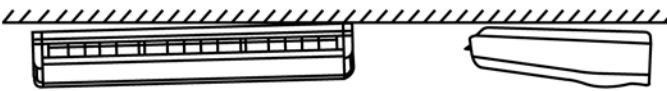
<p>When the drain piping is connected to the right side</p>	 <ul style="list-style-type: none"> <li>• The unit should be level, or the back right should be inclined down. (Within one degree).</li> </ul>
<p>When the drain piping is connected to the left side</p>	 <ul style="list-style-type: none"> <li>• The unit should be level, or the back left sound be inclined down. (Within one degree).</li> </ul>

### 10.4.4. Refrigerant piping

Refrigerant is charged to the outdoor unit. For details, see the manual for installation work of outdoor unit. (Additional charging, etc.)

1. Brazing for piping.
  - a. Execute brazing before tightening the flare nut.
  - b. Brazing must be executed while blowing nitrogen gas.  
(This prevents generation of oxidized scale in copper pipe.)
2. When there is a lot of brazing for long piping, install a strainer at the midway of the piping.  
(The strainer is locally supplied.)
3. Use clean copper pipe with inner wall surface free from mist and dust. Blow nitrogen gas or air to blow off dust in the pipe before connection.
4. Form the piping according to its routing. Avoid bending and bending back the same piping point more than three times.  
(This will result in hardening of the pipe).
5. After deforming the pipe, align centers of the union fitting of the indoor unit and the piping and tighten them firmly with wrenches.
6. Connect pipe to the service valve or ball valve which is located below the outdoor unit.
7. After completed the piping connection, be sure to check if there is gas leakage in indoor and outdoor connection.

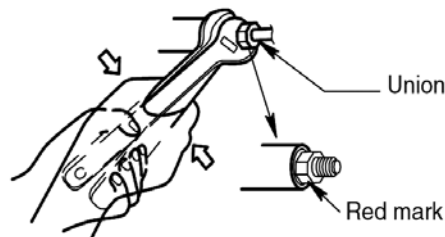

- Confirm the red mark of the union (thin side) is always at lower direction after connecting piping.

### Vacuum drying

After completing the piping connection, execute vacuum drying for the connecting piping and the indoor unit. The vacuum drying must be carried out by using the service ports of both the liquid and gas side valves.

CAUTION Use two wrenches and tighten with regular torque.

Flare nut fastening torque N.m (kgf.cm)			
ø6.35 mm	18 (180)	ø15.88 mm	65 (660)
ø9.52 mm	42 (430)	ø19.05 mm	100 (1020)
ø12.7 mm	55 (560)		

Liquid side piping	Gas side piping
ø9.52 mm	ø15.88 mm

### 10.4.5. Indoor unit drain piping

- Be sure to use the drain hose provided (accessory item.)
- Drain piping must have down-slope (1/50 to 1/100): be sure not to provide up-and-down slope to prevent reversal flow.
- During drain piping connection, be careful not to exert extra force on the drain port at the indoor unit.
- The outside diameter of the drain connection at the indoor unit is 20 mm.

Piping material: Polyvinyl chloride pipe VP-20 and pipe fittings

Heat insulation material: Polyethylene foam with thickness more than 8mm (local supply).

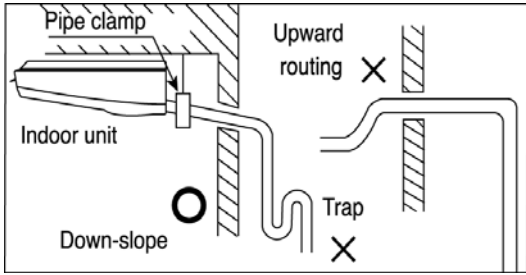

**⚠ Caution** Be sure to perform heat insulation on the drain piping. If insulation is insufficient, dew may form. This causes water leakage.

**⚠ Caution** Prevent the drain hose from floating and hanging down. This causes water leakage. (down figure)

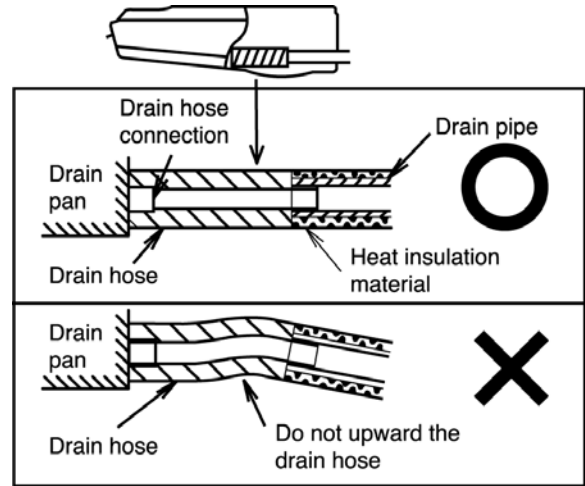

#### In the case of left piping

1. Remove both the internal and external plugs.
2. Use a wrench or pliers to remove the plugs.
  - Putting substitution of rubber plug.

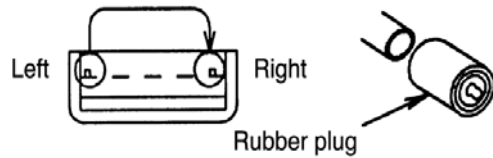

#### Drain Test

- Confirm the drain water flows smoothly after connecting the drain piping.
- Pour water to about 1.5 liters for the drain confirmation from the air inlet part which should gradually flow into the drain pan.

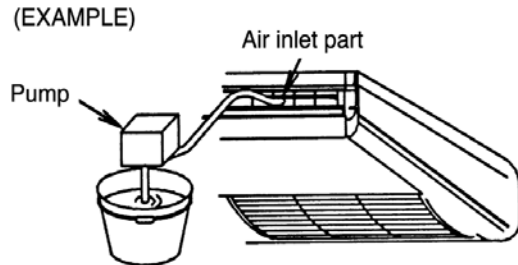

### 10.4.6. Heat insulation

**⚠ Caution** Be sure to perform heat insulation on the drain, liquid and gas piping. Imperfection in heat insulation work leads to water leakage.

1. Use the heat insulation material for the refrigerant piping which has an excellent heat-resistance (over 100°C).

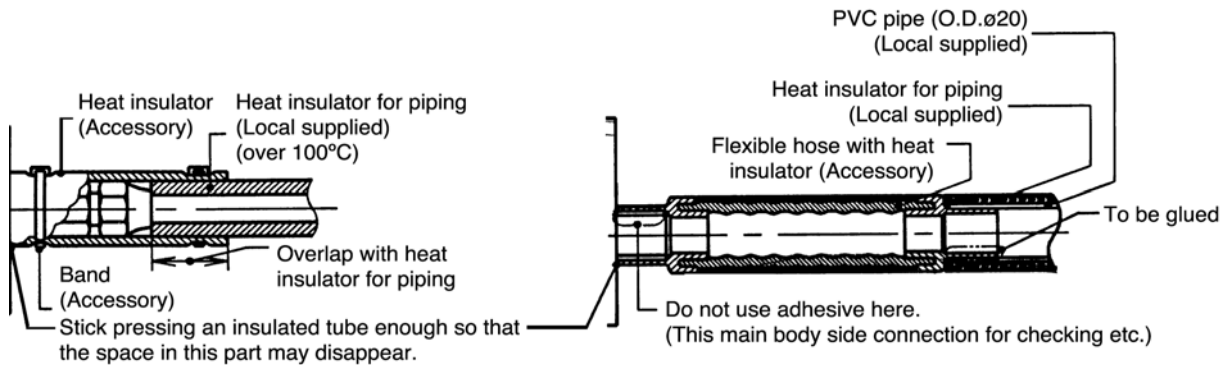

2. Precautions in high humidity circumstance.

This air conditioner has been tested according to the "JIS Standard Conditions with Mist" and have been confirmed that there is no form of any faults. However, if it is operated for a long time in high humid atmosphere (dew point temperature: more than 23°C), water drops are liable to fall.

- In addition to the normal heat insulation (thickness: more than 8 mm) for refrigerant piping (gas piping: thick piping) and drain piping, add a further of 10 mm to 30 mm thickness material.

**Wall seal**

- When the outdoor unit is installed on a higher position than the indoor unit, install the trap so as not to instill rain water into the wall by transmitted in piping.
- Stuff the space among piping, the electric wire, and the drain hose with "Putty" and seal the penetration wall hole. Make sure that rain water do not instill into the wall.

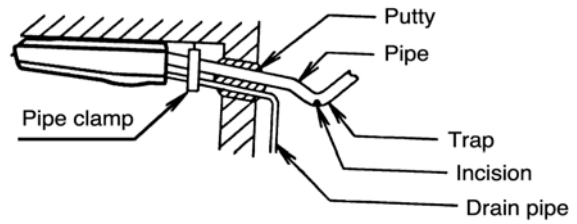

\* Put the incision at the trap part of the heat insulator (for water drainage)

**10.4.7. Electrical wiring**

As to the main power source and cable size of outdoor unit, read the installation manual attached to the outdoor unit.

<b>Warning</b>	The units must be connected to the supply cables for fixed wiring by qualified technician. Feed the power source to the unit via a distribution switch board designed for this purpose, the switch should disconnected all poles with a contact separation of at least 3mm. When the supply cable is damaged, it must be replaced by qualified technician.
	Be sure to install a current leakage breaker, main switch and fuse to the main power supply, otherwise electric shocks may result. Be sure to connect the unit to secure earth connection. If the earthing work is not carried out properly, electric shock may result.
	
	Wiring shall be connected securely using specified cables and fix them securely so that external force of the cables may not transfer to the terminal connection section. Imperfect connection and fixing leads to fire, etc.

1. Select a power source that is capable of supplying the current required by the air conditioner.
2. Be sure to connect the wires correctly to terminal board with connecting the crimp type ring terminal to the wires.
3. Be sure to turn off the main power before installing and connecting the remote controller.

Note	If momentarily turning on the power supply for both the indoor and outdoor units, do not turn the power off after again until at least 1 minute has passed. (for the system's automatic setting.)  Turning off the power supply on the way may cause an abnormal operation.
------	---

- Use the standard power cord for Europe (such as HO5RN-F or HO7RN-F which conforms to CENELEC (HAR) rating specifications) or use the cable based on IEC standard. (245IEC57, 245IEC66)

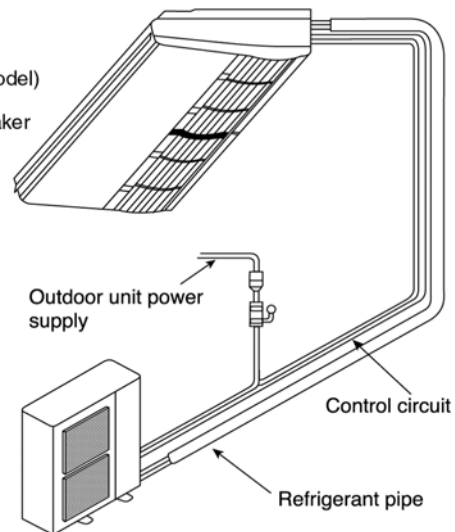
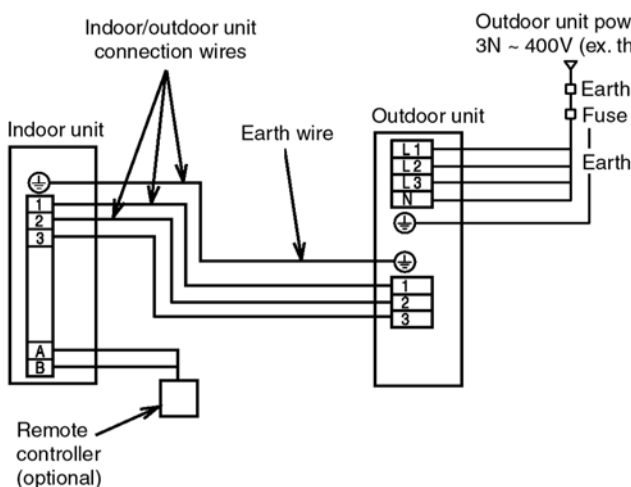

### CONNECTING THE WIRES TO THE CONTROL BOX

- Remove a two mounting screw, remove the control box cover, and then connect the wires by following the procedure given in the illustration.

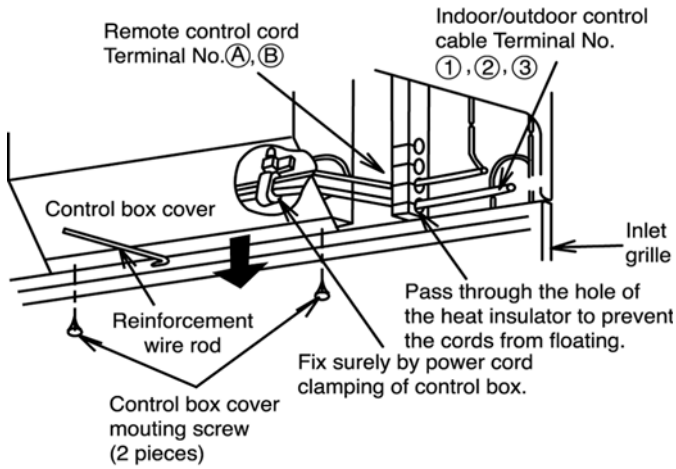

**Caution** Make sure that screws of the terminal are securely tightened.

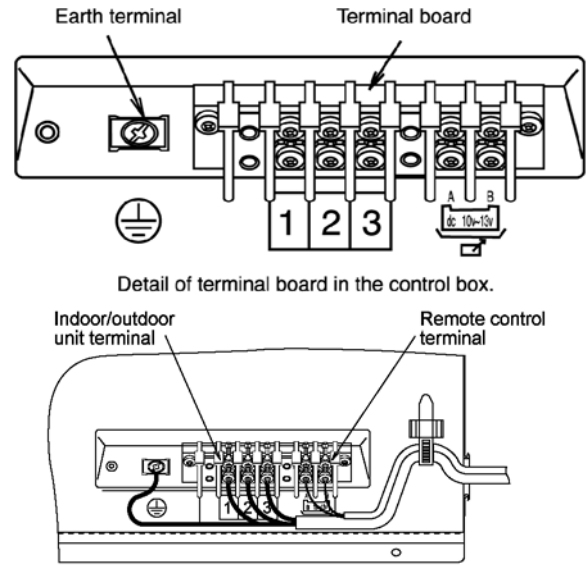

Earth lead wire shall be longer than other lead wires as shown in the figure for the electrical safety in case of the slipping out of the cord from anchorage.

### 10.4.8. Settings

- ⊗ Do not operate the remote controller within 1 minute after turning on the power of the indoor unit.
- ⊗ When using group control with the standard type, at least 1 unit must be set at No.1 at the indoor unit.
- ⊗ Check the settings of the indoor unit in a case where there are no display at remote controller. If there is no problem to the settings, either group control or standard type should be set at No.16 at the indoor unit before turning the power on again.
- All sets in the group which uses the same remote controller thermistor settings can be controlled by the same remote controller thermistor.
- Up to a maximum of 16 indoor units can be connected at the time of group control. (Do not connect heat pump unit with cooling only unit.)
- Indoor unit No. will be set automatically at the time of group control. However, which indoor unit uses which number is unknown. Indoor unit No. is also possible to be set manually with DIP switches. Since manual address setting has priority to automatic address setting. To perform automatic address settings after doing manual setting, turn off all DIP switches from No.1 to No.4, and then stop the operation. Then press three switches such as [AIR SWING AUTO]. [MODE]. [A/C No.] at the same time. (Do not use manual address setting and automatic address setting together.)
- Centralized control is possible for master unit and slave unit at the time of group control.

	Indoor unit No.	1	2	3	4	5	6	7	8
Manual Setting	DIP switch (SW2) address setting on indoor unit printed circuit board.	OFF ON 1 2 3 4	OFF ON 1 2 3 4	OFF ON 1 2 3 4	OFF ON 1 2 3 4	OFF ON 1 2 3 4	OFF ON 1 2 3 4	OFF ON 1 2 3 4	OFF ON 1 2 3 4
	A/C No. setting	Unnecessary operation	1 - ON	2 - ON	1,2 - ON	3 - ON	1,3 - ON	2,3 - ON	1,2,3 - ON
	Indoor unit No.	9	10	11	12	13	14	15	16
	DIP switch (SW2) address setting on indoor unit printed circuit board.	OFF ON 1 2 3 4	OFF ON 1 2 3 4	OFF ON 1 2 3 4	OFF ON 1 2 3 4	OFF ON 1 2 3 4	OFF ON 1 2 3 4	OFF ON 1 2 3 4	OFF ON 1 2 3 4
	A/C No. setting	4 - ON	1,4 - ON	2,4 - ON	1,2,4 - ON	3,4 - ON	1,3,4 - ON	2,3,4 - ON	1,2,3,4 - ON

**(Remote Control Address Setting)**

(Refer to the Operation Manual which is provided with the remote controller for details.)

- Two remote controllers (including the wireless remote controller) can be connected. However, remote control thermistor setting is not possible.
- As for [master/slave] setting of remote controller, the automatic setting and manual setting are possible. Since manual setting is priority.
- Two remote controllers, which both are wireless, cannot be connected.

**10.4.9. As for timer output**

- Connect the timer cord to connector (CN-TIMER) on print circuit board.

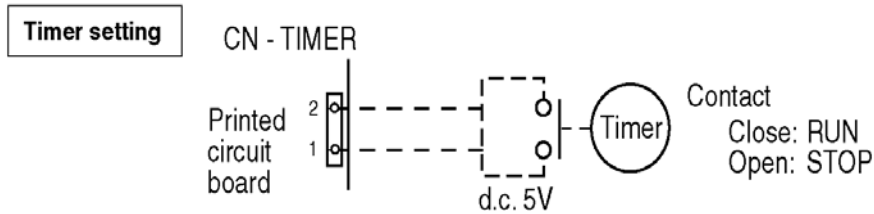

**10.4.10. Precautions in test run**

- The initial power supply must provide at least 90% of the rated voltage. Otherwise, the air conditioner may not operate.
- Test operation can be carried out using the remote control unit or at the outdoor unit. (If carrying out test operation at the outdoor unit, refer to "TEST OPERATION" in the outdoor unit installation manual.)
- If using the remote control unit to carry out test operation, follow the procedure given below.



- First, press the OFF/ON (⓪) button.
- Then press the TEST RUN button within 1 minute of pressing the OFF/ON (⓪) button.
- Next, select the operation modes.
- The temperature of the indoor unit pipes will be shown on the temperature setting display. (At the start of the test operation, it may take up to 1 minute for air conditioner number, switching time and other displays to appear.)
- After operation modes have been selected, stop the compressor for a moment.
- Press the OFF/ON (⓪) button of the TEST RUN button once more to cancel test operation mode.

**NOTE 1** These units are equipped with connection error prevention circuits. If the units do not operate, it is possible that the connection error prevention circuits have operated. In such cases, check that the power wires (connected to terminals ① and ②) and the control wires (③) are connected correctly. If they are connected incorrectly, connect them correctly. Normal operation should then commence.

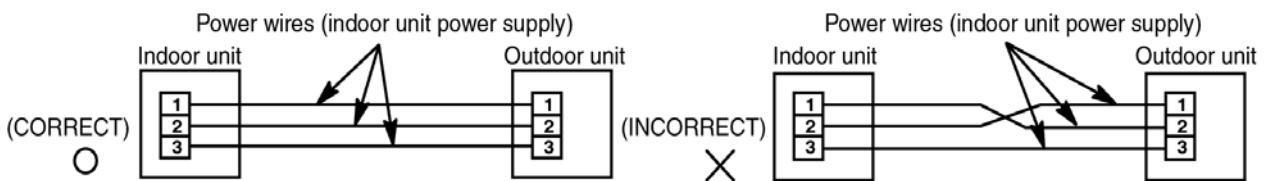

**NOTE 2** Do not short the remote control unit wires to each other. (The protection circuit will be activated and the units will not operate.) Once the cause of the short is eliminated, normal operation will then be possible.

**NOTE 3** When running the units in heating mode during test operation, be sure to run the units in cooling mode first before selecting this mode. If heating mode is selected first, it may cause problems with operation of the compressor. (Heat pump model only.)

**NOTE 4** Test operation should be carried out for a minimum of 5 minutes. (Test operation will be cancelled automatically after 30 minutes.)

**NOTE 5** Test operation mode should always be cancelled once test operation itself has been completed.



#### 10.4.11. Check the following items when installation is complete

- After completing work, be sure to measure and record trial run properties, and store measuring data, etc.
- Measuring items are room temperature, outside temperature, suction temperature, blow out temperature, wind velocity, wind volume, voltage, current, presence of abnormal vibration and noise, operating pressure, piping temperature, compressive pressure, airtight pressure.
- As to the structure and appearance, check the following items.

Is circulation of air adequate?

Is draining smooth?

Is heat insulation complete (refrigerant and drain piping)?

Is there any leakage of refrigerant?

Is remote controller switch operated?

Is there any faulty wiring?

Are the terminal screws loosened?

M3...69-98 N•cm {7-10 kgf•cm}

M4...157-196 N•cm {16-20 kgf•cm}

M5...196-245 N•cm {20-25 kgf•cm}

#### 10.4.12. Hand over

- Teach the customer the operation and maintenance procedures, using the operation manual (air filter cleaning, temperature control, etc.)

#### As to parts to be sold separately

- With regards to installation of the parts sold separately, follow the installation manual which is provided with the parts sold separately

**As for work specifications of the outdoor unit, read the OUTDOOR UNIT INSTALLATION MANUAL attached to the outdoor unit.**

## 10.5. Outdoor unit installation

### AIR CONDITIONERS OUTDOOR UNIT INSTALLATION INSTRUCTIONS

**REFRIGERANT  
R410A**

HP	Model name	
1.5 HP	CU-B14DB**	CU-J14DB**
2 HP	CU-B18DB**	CU-J18DB**
2.5 HP	CU-B24DB**	CU-J24DB**
3 HP	CU-B28DB**	CU-J28DB**
4 HP	CU-B34DB**	CU-J34DB**
5 HP	CU-B43DB**	CU-J43DB**
6 HP	CU-B50DB**	CU-J50DB**

#### Precautions in terms of safety

Carry out installation work with reliability after thorough reading of this "Precautions in terms of safety".

- Precautions shown here are differentiated between ⚠ Warnings and ⚠ Cautions. Those that have much chances for leading to significant result such as fatality or serious injury if wrong installation would have been carried out are listed compiling them especially into the column of ⚠ Warnings.

However, even in the case of items which are listed in the column of ⚠ Cautions, such items also have a chance for leading to significant result depending on the situations.

In either case, important descriptions regarding the safety are listed, then observe them without fail.

- As to indications with illustration

 This mark means "Caution" or "Warning".

 This mark means "Earth".

- After installation work has been completed, do not only make sure that the unit is free from any abnormal condition through the execution of try run but also explain how to use and how to perform maintenance of this unit to the customer according to the instruction manual.

In addition, request the customer to keep this manual for installation work together with instruction manual.

#### ⚠ Warnings

<p>▲ The appliance must be installed by technician, who takes into account the requirements given by ISO5149 or eventual equivalent requirements.</p>	<p>▲ Wiring shall be connected securely using specified cables and fix them securely so that external force of the cables may not transfer to the terminal connection section. Imperfect connection and fixing leads to fire, etc.</p>
<p>▲ As to installation, request the distributor or vendor to perform it. Imperfection in installation caused by that having been carried out by the customer himself may lead to water leakage, electric shock, fire, etc.</p>	<p>▲ If installing inside a small room, measures should be taken to prevent refrigerant levels from building up to critical concentrations in the event of a refrigerant leak occurring. Please discuss with the place of purchase for advice on what measures may be necessary to prevent critical concentrations being exceeded. If the refrigerant leaks and reaches critical concentration levels, there is the danger that death from suffocation may result.</p>
<p>▲ Carry out the installation work with reliability according to this manual for installation work. Imperfection in installation leads to water leakage, electric shock, fire, etc.</p>	<p>▲ Securely attach the protective covers for the outdoor unit connection cables and power cord so that they do not lift up after installation. If the covers are not properly attached and installed, the terminal connections may overheat, and fire or electric shock may result.</p>
<p>▲ Carry out the installation work with reliability on the place that can bear the weight of this unit sufficiently. Insufficient strength leads to injury due to falling of the unit.</p>	<p>▲ Switch off all supplies before accessing any electrical part.</p>
<p>▲ Carry out predetermined installation work in preparation for strong wind such as typhoon, earthquake. Imperfection in installation work may lead to accidents arisen from overturn, etc.</p>	<p>▲ If refrigerant gas escapes during installation, ventilate the affected area. If the refrigerant gas comes into contact with sparks or naked flames, it will cause toxic gases to be generated.</p>

**⚠ Warnings**

<p>▲ The unit must be installed in accordance with applicable national and local regulations. Any electrical work should only be carried out by qualified technician and use exclusive circuits without fail. Presence of insufficient capacity in power circuit or imperfection in execution leads to electric shock, fire, etc.</p>	<p>▲ Once installation work is completed, check that there are no refrigerant gas in the room that can come into contact with sparks or flames from a fan heater, stove or kitchen range, which will cause toxic gases to be generated.</p>
<p>▲ When performing piping work do not mix air except for specified refrigerant (R410A) in refrigeration cycle. It causes capacity down, and risk of explosion and injury due to high tension inside the refrigerant cycle.</p>	<p>▲ Earth This equipment must be properly earthed. Earth line must not be connected to earth of gas pipe, water pipe, lightning rod and telephone. Otherwise, it may cause electrical shock in case the equipment breakdown or has leakage current.</p>
<p>▲ Installation of Earth Leakage Current Breaker. This equipment must be installed with earth leakage current breaker. Otherwise, it may cause electrical shock and fire in case the equipment breakdown or has leakage current.</p>	



**⚠ Cautions**

<p>▲ Do not install the unit at the place where the possibility of inflammable gas leakage exists. If such gas leakages should arise and the gas builds up around the unit, such situation may lead to ignition.</p>	<p>▲ Drain piping should be made to ensure secure drainage according to the manual for installation work and carry out the thermal insulation to prevent the occurrence of condensation. Imperfection in piping work leads to water leakage and may cause the house and property, etc. to become wet</p>
<p>▲ Position the indoor unit and outdoor unit, power cords and indoor/outdoor unit connection cables in a way so that they are at least 1 meter away from televisions and radios. This is to avoid problem such as interference with picture and/or sound. (However, note that depending on the electromagnetic wave conditions, interference may still occur even if the separation distance is more than 1 meter.)</p>	

### 10.5.1. Accessories supplied with outdoor unit

- The following parts are supplied as accessories with each outdoor unit.  
Check that all accessory parts are present before installing the outdoor unit.

Part name	Q'ty	Diagram	Application
Protective bushing	2		For protecting electrical wires
Banding strap	3		For tying electrical wires together

Heat pump-types only			
Part name	Q'ty	Diagram	Application
Drain elbow AS	1		For connecting the drain pipe (with ring seat)

### 10.5.2. Before installation work

- This product is using new refrigeration (R410A). The basic way of installation work is the same as usual, but water and impurities should be controlled more strictly than before due to characteristic of refrigerating machine oil. Therefore, selection of materials to use and processing, storing and brazing need appropriate construction and control.

1. Tools and materials

There are tools and materials for both new refrigeration and usual refrigeration you can use together and for either two of them you can use. Use the below for new refrigeration.

- Vacuum pump (with back flow preventor system)
- Gas leakage detection warning device
- Gauge manifold
- Charge hose

2. Installation work

a. Brazing work

Brazing work needs replacing air inside pipe with nitrogen gas in order to prevent oxidation scale from occurring. This is called nitrogen replacement, and one of very important work in brazing refrigerant piping. (Oxidation preventive is not possible to use)

(Work method)

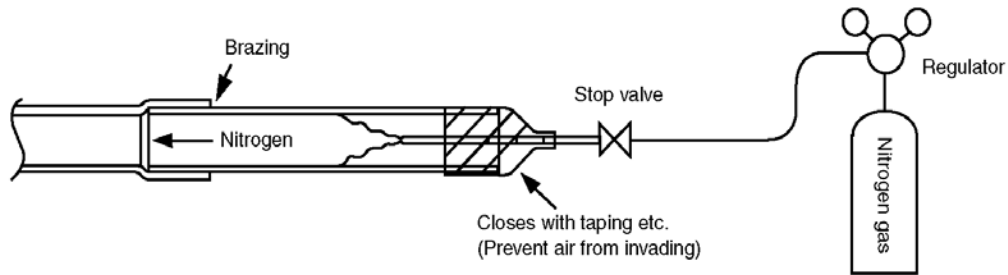

b. Prevention measure for refrigerant piping

Prevention measure for refrigerant piping is very important work to prevent water-dust-rubbish from getting in. All piping terminals needs sealing such as shown below.

Place	Period of work	Method of seal
Outside	More than 1 month	Pinch
	Less than 1 month	Pinch or taping
Inside	Not specified	

• How to pinch

Close terminal part of piping with pliers and seal the gap with brazing.

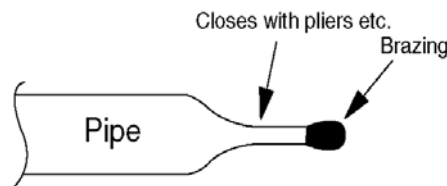

• How to tape

Seal terminal part of piping with vinyl tape.

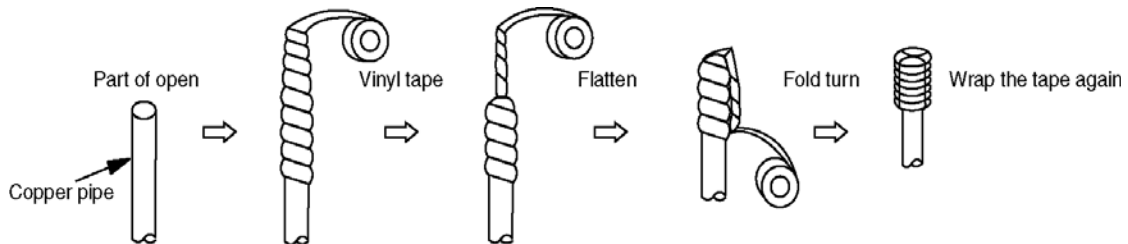

3. Vacuum pumping

The purpose of vacuum pumping work is to remove and dry air inside the piping or nitrogen at air tightness test. Perform the work carefully.

**⚠ Caution** Use the vacuum pump with the backflow prevention mechanism to prevent backflow of oil.

Vacuuming time      60 minutes or more

⊗ Vacuum pump capacity  
60 l/min or more

#### 4. Refrigerant filling

Refrigerant filling must be done in the state of liquid refrigerant. If this is done in gas refrigerant, the balance of refrigerant composition will collapse and damage the operation.

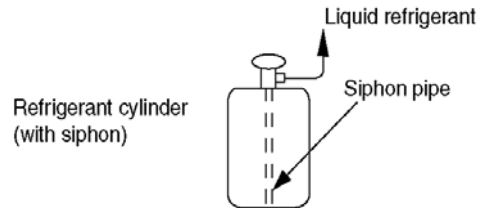

For the use of a gas cylinder without siphon inside, turn it upside down and use it.  
(We recommend manifold with sight glass.)

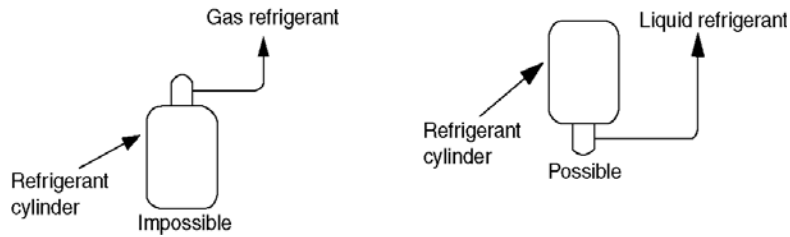

<b>Caution</b>	Do not use a "CHARGE CYLINDER".
----------------	---------------------------------

<b>Caution</b>	As a rule, please collect all existing refrigerants in the system outside the system when the refrigerant leakage occurs by the system. After that, please fill new refrigerant of a regulated amount again.
----------------	---

#### DRY VACUUMING

- If vacuum pump possible vacuuming until less than -100.7kpa.
  1. Running vacuum pump at both liquid and gas side for more than 1 hour and vacuuming until -100.7kpa.
  2. After that keep the pressure -100.7kpa for 1 hour and confirm the vacuum gauge value not increasing.
  3. If vacuum gauge value is increase, there is possibility of water inside the unit or there is any leakage.

#### 10.5.3. Regarding handling

Handling the unit by hold the handle at compressor side and hold the basepan bottom at fan side.

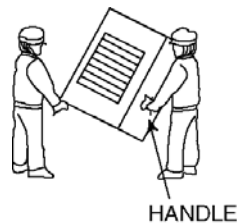

#### 10.5.4. Selecting the outdoor unit installation locations

- Select location which satisfies the following condition, and then confirm with the customer that such a place is satisfactory before installing the outdoor unit.
  1. There should be sufficient ventilation.
  2. The outdoor unit should be sheltered as much as possible from rain and direct sunlight, and the air should be able to move around so that hot and cold air do not build up.

3. There should not be animals or plants near the air outlet which could be adversely affected by hot or cold air coming out from the unit.
4. The outlet air and operating noise should not be a nuisance to other occupants nearby.
5. The location should be able to withstand the full weight and vibration of the outdoor unit, and it should also be level and safe for the unit to be installed.
6. The intake and outlet should not be covered.
7. There should not be danger of flammable gas or corrosive gas leaks.
8. There should be as little back-ventilation (air blowing directly onto the fan) as possible.

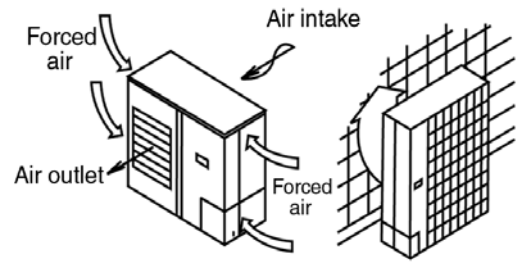

(If strong wind blows directly onto the fan, it may cause problems with normal operation.)

- If you know which direction the prevailing wind comes from during the operating season, set the outdoor unit at a right-angle to this wind direction, or so that air outlet faces toward a wall or fence.
  - If there are obstructions near the outdoor unit and the wind direction is not constant, install an optional air guider.
9. Do not allow any obstacles near the outdoor unit which will interfere with air flow around the air intake and air outlet.
  10. If installing in a location which is prone to snowfall, place the installation base as high as possible, and be sure to install a roof or enclosure which does not allow snow to accumulate.
  11. Avoid installing the unit in places where petroleum products (such as machine oil), salinity, sulphurous, gases or high-frequency noise are present.
  12. Be sure to leave enough space around the outdoor unit to maintain proper performance and to allow access for routine maintenance.
    - Allow enough space from any obstacles as shown in Fig. 1.2 below in order to prevent short-circuits from occurring. (If installing more than one outdoor unit, make the necessary space available as outlined in 13.) However, there should be at least 1 meter of free space above the unit.
    - The height of any obstacles at the air intake and outlet sides should not be greater than the height of the outdoor unit.

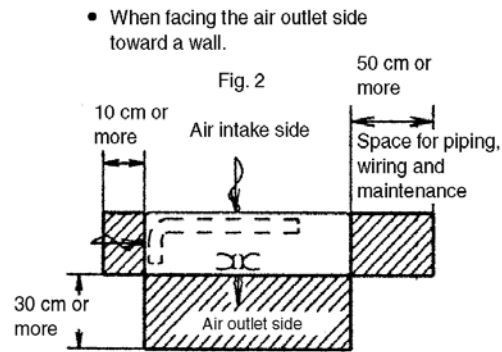
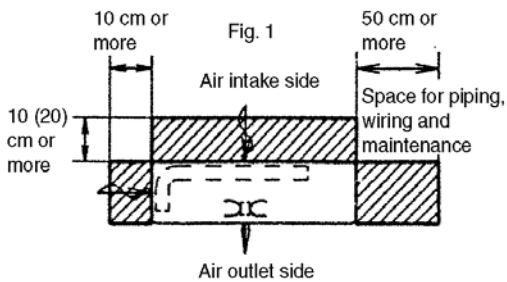

13. If installing more than one outdoor unit, allow enough space around each unit as shown below.

- When installing units side by side

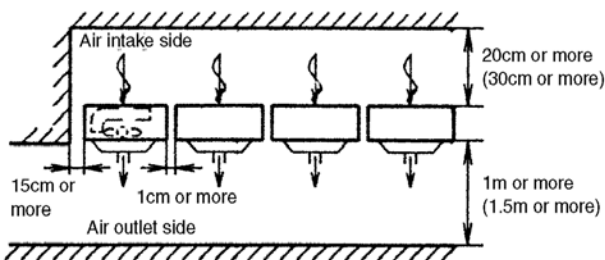

- When installing units facing each other

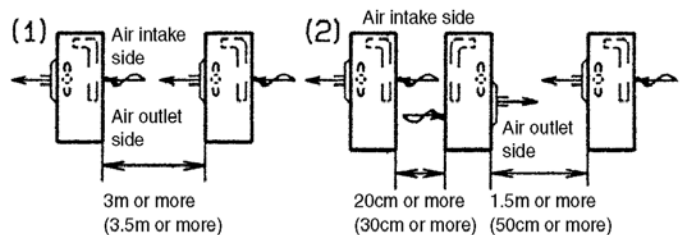

⊗ Maintain sufficient space above the unit.

Values inside brackets indicate distances when installing the 4HP - 6HP.

- The distance given above are the minimum distance required in order to maintain proper performance. Allow as much space as possible in order to get the best performance from the units.

### 10.5.5. Transporting and installing the outdoor unit

- Transporting
  1. The outdoor unit should be transported in its original packaging as close to the installation location as possible.
  2. If suspending the outdoor unit, use a rope or belt, and use cloth or wood as padding in order to avoid damaging the unit.
- Installation
  1. Read the “Selecting the outdoor unit installation location” section thoroughly before installing the outdoor unit.
  2. If installing the unit to a concrete base or other solid base, use M10 or W3/8 bolts and nuts to secure the unit, and ensure that the unit is fully upright and level.  
(The anchor bolt positions are shown in the diagram at the right side.)  
In particular, install the unit at a distance from the neighbouring building which conforms to regulations specified by local noise emission regulation standards.
  3. Do not install the outdoor unit to the building’s roof.
  4. If there is a possibility that vibration may be transmitted to the rooms of the building, place rubber insulation between the unit and the installation surface.
  5. Drain water will be discharged from the outdoor unit when operating the system in heating or defrosting modes. Select an installation location which will allow the water to drain away properly, or provide a drainage channel so that the water can drain away.  
(If this is not done, the drain water may freeze during winter, or the water may spill down to areas underneath the installation location.)

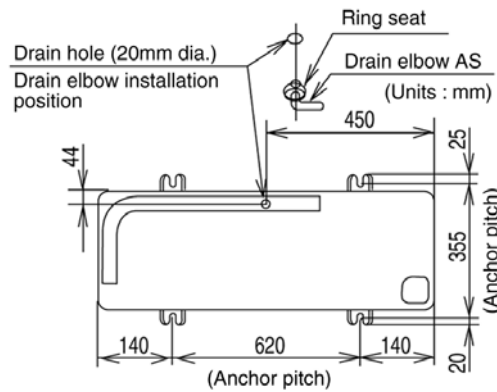

- If a drain pipe needs to be installed, insert the accessory drain elbow into the mounting hole at the bottom of the outdoor unit, and connect a hose with an inside diameter of 15mm to this drain elbow.  
(The hose is not supplied.)
- ✗ If using the drain elbow, install the outdoor unit on a base which is at least 5cm high.

**NOTE** In cold regions (where the outdoor air temperature can drop to 0°C or below continuously for 2-3 days), the drain water may freeze, and this may prevent the fan from operating. Do not use the drain elbow in such cases.

### 10.5.6. Connecting the pipes

- Use a clean pipe which does not include water or dust for inside of piping.
- When cutting the refrigerant pipes, a piping cutter must be used. Before connecting the refrigerant pipes, blow nitrogen and blow off dust in the pipes.  
(Never use tools which cause a lot of dust such as a saw and a magnet.)
- When waxing replace nitrogen inside the piping after removing dirt and dust. (In order to prevent oxidation scale from forming inside the piping).
- The refrigerant pipes are of particular importance.  
The installation work for refrigerant cycles in separate-type air conditioners must be carried out perfectly.

1. Refer to the table below for the pipe diameters equivalent lengths and indoor/outdoor unit difference of elevation.

Model	Pipe diameter (mm)		Equivalent length (m)	Difference of elevation (m)
	Liquid-side pipes	Gas-side pipes		
1.5 HP • 2 HP	ø6.35 × t0.8	ø12.7 × t0.8	30	20
2.5 HP ~ 6 HP	ø9.52 × t0.8	ø15.88 × t1.0	50	30

2. Local pipes can project in any of four directions.

- Make holes in the pipe panels for the pipes to pass through.
- Be sure to install the pipe panels to prevent rain from getting inside the outdoor unit.  
[Removing the service panel].

- (1) Remove the two mounting screws.
- (2) Slide the service panel downward to release the pawls. After this, pull the service panel toward you to remove it.

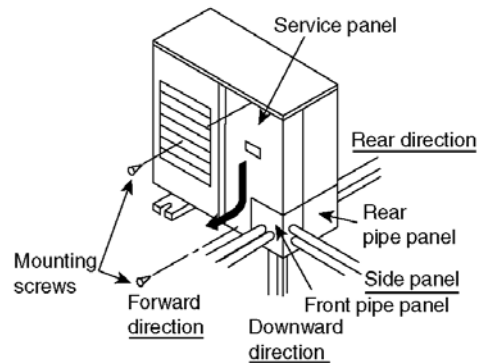

3. Notes when connecting the refrigerant pipes.

- Use clean copper, pipes with no water or dust on the insides.
- Use phosphorus-free, unjointed copper pipes for the refrigerant pipes.
- If it is necessary to cut the refrigerant pipes, be sure to use a pipe cutter, and use compressed nitrogen or an air blower to clean out any foreign particles from inside the pipe.
- Be careful not to let any dust, foreign materials or water get inside the pipes during connection.
- If bending the pipes, allow as large a bending radius as possible. Do not flex the pipes any more than necessary.
- If joining pipe ends, do so before tightening the flare nut.
- Always blow the pipe end with nitrogen while joining pipe ends.  
(This will prevent any oxide scaling from occurring inside the pipe.)
- If using long pipe lengths with several joined pipe ends, insert strainers inside the pipes. (Strainers are not supplied.)
- When tightening the flare nuts, coat the flare (both inside surfaces) with a small amount of refrigerator oil, and screw in about 3-4 turns at first by hand.
- Refer to the following table for the tightening torques. Be sure to use two spanners to tighten.  
(If the nuts are overtightened, it may cause the flares to break or leak.)

Flare nut fastening torque N•m (kgf•cm)			
ø6.35 mm	18 (180)	ø15.88 mm	65 (660)
ø9.52 mm	42 (430)	ø19.05 mm	100 (1020)
ø12.7 mm	55 (560)		

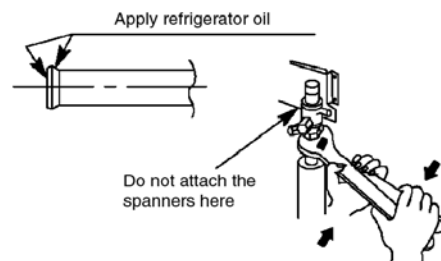

4. After piping connection has been completed, make sure that the joint areas of the indoor and outdoor units are free from gas leakage by the use of nitrogen, etc.
5. Air purge within connection piping shall be carried out by evacuation.
6. Close the tube joining area with putty heat insulator (local supply) without any gap as shown in below figure.  
(To prevent insects or small animal entering)

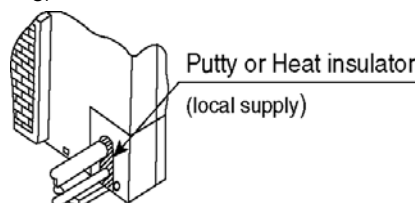



### 10.5.7. Heat insulation

⚠ Caution	Use a material with good heat-resistant properties as the heat insulation for the pipes. Be sure to insulate both the gas-side and liquid-side pipes. If the pipes are not adequately insulated, condensation or water leakages may occur.
-----------	--

Liquid-side pipes	Material that can withstand 120°C or higher
Gas-side pipes	

### 10.5.8. Charging with refrigerant

#### 1.5 HP • 2 HP (14 • 18 type)

- At the time of shipment from the factory, this unit is charged with enough refrigerant for an equivalent pipe length of 20m. If the equivalent pipe length used will be 20m or less, no additional charging will be necessary.
- If the equivalent pipe length will be between 20 and 30m, charge with additional refrigerant according to the equivalent length given in the table below.

#### 2.5 HP ~ 6 HP (24 ~ 50 type)

- At the time of shipment from the factory, this unit is charged with enough refrigerant for an equivalent pipe length of 30m. If the equivalent pipe length used will be 30m or less, no additional charging will be necessary.
- If the equivalent pipe length will be between 30 and 50m, charge with additional refrigerant according to the equivalent length given in the table below.

Model	Additional charging amount	Equivalent length
1.5 HP • 2 HP (14 • 18 type)	0.02 kg/m	30m
2.5 HP ~ 6 HP (24 ~ 50 type)	0.05 kg/m	50m

- Pump down operation
  - Operate the pump down according to the following procedures.

Procedure	Notes
1. Confirm the valve on the liquid side and the gas side is surely open.	
2. Press the PUMP DOWN switch on outdoor printed board for 1 second or more.	Perform the cooling operation for five minutes or more.
3. Shut the valve on the liquid side surely.	When the valve is shut halfway, the compressor is occasionally damaged.

### 10.5.9. Electrical wiring

⚠ Warning	The units must be connected to the supply cables for fixed wiring by qualified technician. Feed the power source to the unit via a distribution switch board designed for this purpose, the switch should disconnected all poles with a contact separation of at least 3mm. When the supply cable is damaged, it must be replaced by qualified technician.
	Be sure to install a current leakage breaker, main switch and fuse to the main power supply, otherwise electric shocks may result.
	Be sure to connect the unit to secure earth connection. If the earthing work is not carried out properly, electric shocks may result.
	Wiring shall be connected securely by using specified cables and fix them securely so that external force of the cables may not transfer to the terminal connection section. Imperfect connection and fixing leads to fire, etc.



- Connect the power supply wiring and indoor/outdoor unit connection wiring according to the electrical circuit diagram instructions.
- Clamp the wires securely to the terminal connections using cord clamps so that no undue force is placed on the wires.
- Once all wiring work has been completed, tie the wires and cords together with the binding strap so that they do not touch other parts such as the compressor and pipes.

1. Connect the power supply line to a 3-phase/380-415V (or single-phase 220-240V) power supply.
2. The equipment shall be connected to a suitable mains network with a main impedance less than the value indicated in the table of power supply specifications.
3. Be sure to connect the wires correctly to terminal board with connecting the crimp type ring terminal to the wires.
4. The binding screws inside the power supply box may become loosened due to vibration during transportation, so check that they are tightened securely.
5. Tighten the binding screws to the specified torque while referring to the table below.
6. If connecting two separate wires to a single crimped terminal, place the two crimped terminal wires together as shown in Fig. A. (If the arrangement shown in Fig. B is used, poor contacts or contact damage may result.)

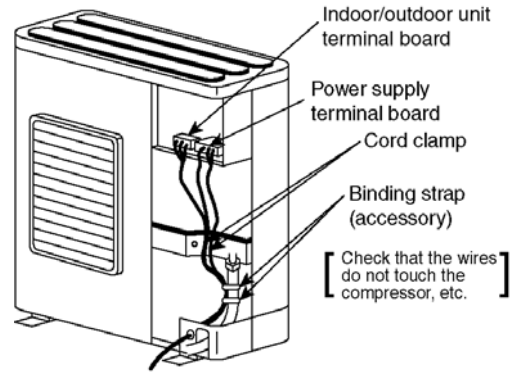

7. If momentarily turning on the power supply for both the indoor and outdoor units, do not turn the power off again until at least 1 minute has passed (except when a reversed phase has been detected).

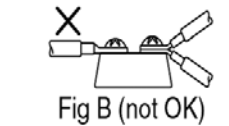
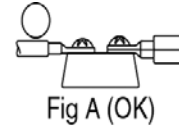

<b>Warning</b>	Use only the specified cables for wiring connections. Connect the cable securely, and secure them properly so that no undue force will be applied to the terminal connections. If the terminals are loose or if the wires are not connected securely, fire may result.
----------------	---

Terminal screw	Tightening torque N.cm {kgf.cm}
M3	69 ~ 98 {7 ~ 10}
M4	157 ~ 196 {16 ~ 20}
M5	196 ~ 245 {20 ~ 25}

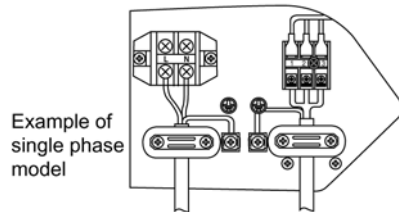

Earth lead wire shall be longer than other lead wires as shown in the figure for the electrical safety in case of the slipping out of the cord from the anchorage.

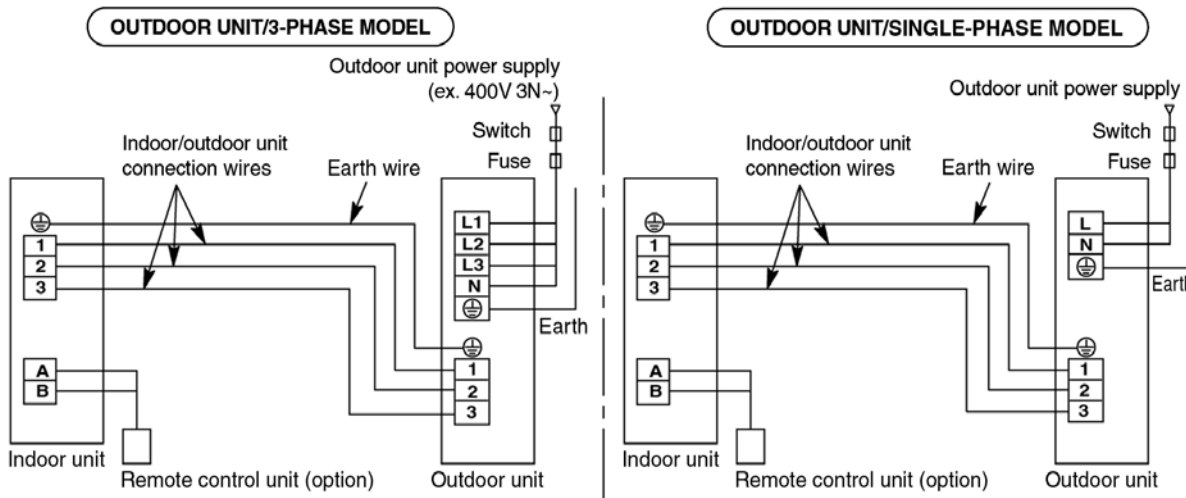

• Power supply specifications

Model name			Leakage current breaker (A)	Circuit breaker (Minimum Capacity)		Minimum power supply cables	4mm <sup>2</sup> cable based on length (m)	Maximum permissible impedance (Ω)	Indoor/outdoor unit connection power cables (terminals ①, ②, ③, ④)
				Switch (A)	Fuse (A)				
CU-B14DBE5	CU-J14DBE5	220V-240V~	15	15	15	4 mm <sup>2</sup>	35	0.0374	2.5 mm <sup>2</sup> × 4
CU-B18DBE8	CU-J18DBE8	220V-240V~	20	20	20		24	0.0374	
CU-B24DBE5	CU-J24DBE5	220V-240V~	30	30	20		16	0.0374	
CU-B24DBE8	CU-J24DBE8	380V-415V 3N~	15	15	15		68	0.1017	
CU-B28DBE5	CU-J28DBE5	220V-240V~	30	30	30		16	0.0374	
CU-B28DBE8	CU-J28DBE8	380V-415V 3N~	15	15	15		59	0.1017	
CU-B34DBE5	CU-J34DBE5	220V-240V~	40	40	40		10	0.0374	
CU-B34DBE8	CU-J34DBE8	380V-415V 3N~	20	20	20		38	0.1017	
CU-B43DBE8	CU-J43DBE8	380V-415V 3N~	20	20	20		27	0.1017	
CU-B50DBE8	CU-J50DBE8	380V-415V 3N~	20	20	20		25	0.1017	

**NOTE**



1. Where ground work (earth) is carried out, do not connect the ground return to the gas pipe, water line pipe, grounded circuit of the telephone and lightning rod, or ground circuit of other product in which earth leakage breaker is incorporated. (Such action is prohibited by statute, etc.)

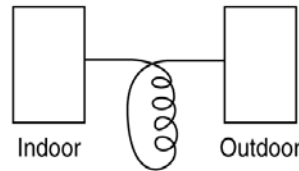

- Make sure the indoor and outdoor connection wires are detangled. (There might be effect to received outside noise.)
2. Use the standard power supply cables for Europe (such as H05RN-F or H07RN-F which conforms to CENELEC (HAR) rating specifications) or use the cables based on IEC standard. (245IEC57, 245IEC66)
  3. Select the particular size of electrical wire for power supply cables in accordance with the standards of the given nation and region.

**10.5.10. Connecting power supply cables**

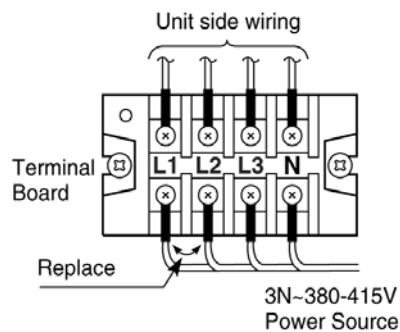

**CAUTION**

- For three phase model, never operate the unit by pressing the electromagnetic switch.
- Never correct the phase by switching over any of the wires inside the unit.

## 10.5.11. Precautions with regard to test operation

- Use only insulation tool to the switch on the microswitch on the electric circuit board. (Do not use your finger or a metallic tool.)
- Do not switch on power before all installation is completed.
- For 3 phase power, make sure the phases are connected correctly. (If the phases are connected incorrectly, LED indicator on the electric circuit board will start flashing.)
- After power on, make sure the voltage is 90% - 110% of the rated voltage.
- May use remote control or corresponding switches on the control panel of the outdoor unit to initiate "Test run". If "Test Run" is initiated using remote control, refer to indoor unit installation.
- Test run consists of ① cooling and ② heating modes (Single mode unit does not have heating function).
- Press and hold SW1 more than 1 second. In DS1, under different setting condition, outdoor unit will perform "cooling" test run or "heating" test run.

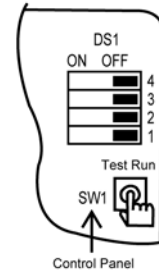

DS1				Operation mode
1	2	3	4	
ON	OFF	×	×	"Cooling" test run
ON	ON	×	×	"Heating" test run
OFF	OFF	×	×	PUMP DOWN

(Must first select "cooling" mode.)

\* When operation mode changes, the compressor stops operation momentary.

- Press SW1 again to cancel test run.
- If outdoor temperature is high during "heating" test run, or low during "cooling" test run, the protection system in the system will be activated within several minutes.

**NOTE 1** These units are equipped with connection error prevention circuits. If the units do not operate, it is possible that the connection error prevention circuits have been operated. In such cases, check that the Indoor/outdoor unit connection wire (connected to terminals ①, ② and ③) is connected correctly. If they are connected incorrectly, connect them correctly. Normal operation should then commence.

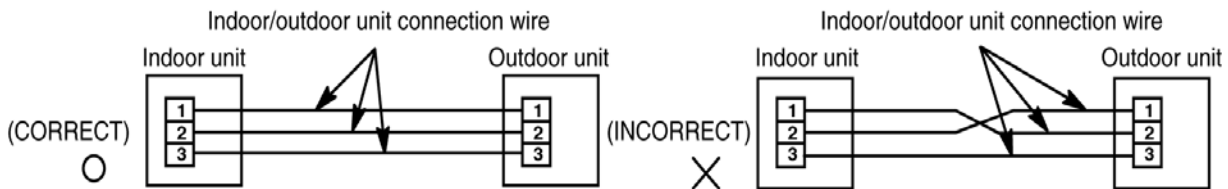

**NOTE 2** Do not short the remote control unit wires to each other. (The protection circuit will be activated and the units will not operate.) Once the cause of the short is eliminated, normal operation will then be possible.

**NOTE 3** When running the units in heating mode during test operation, be sure to run the units in cooling mode first before selecting this mode. If heating mode is selected first, it may cause problems with operation of the compressor.

**NOTE 4** Be sure to select cooling mode first, and run the unit in this mode for 5 minutes or more. If the cooling operation is not executed first for five minutes or more, the heating operation can not be executed. (Test operation will be cancelled automatically after 30 minutes.)

**NOTE 5** Test operation mode should always be cancelled once test operation itself has been completed.

**NOTE 6** If the self-diagnosis function reports a problem but more than one problem has developed at the indoor and/or outdoor units, the problem display on the remote control unit may not match the LED display on the outdoor unit printed circuit board. In such cases, check both locations and remove the causes of the problems.

### 10.5.12. As to making the inspection after completion of work fully understood

- At the time when the work has been completed, measure and record the characteristics of test run without fail and keep the measuring date, etc.
- Carry out the measurement regarding room temperature outside air temperature, suction and air discharge temperatures, wind velocity, wind volume, voltage current, presence of abnormal vibration, operating pressure, piping temperature, compressive pressure, airtight pressure as items to be measured.
- As to the structure and appearance, check following items.

- Short circuit of the blow-out air
- Smooth flow of the drain
- Reliable thermal insulation
- Leakage of refrigerant
- Mistake in wiring

- Reliable connection of the ground wire
- Looseness in terminal screw, fastening torque  
M3... 69-98N•cm {7-10kgf•cm} M4... 157-196N.cm {16-20kgf•cm}  
M5... 196-245N•cm {20-25kgf•cm}

### 10.5.13. As to delivery to the customer





- Request the customer to operate this air conditioner viewing instruction manual come with indoor unit in practice and explain how to operate.
- Deliver the instruction manual to the customer without fail.

## 10.6. Wired remote control installation

### Wired Remote Control Installation Manual

- Before installing the wired remote controller, be sure to thoroughly read the “Notes with regard to safety” section of the installation manual provided with the indoor unit.
- After installing the wired remote controller, carry out a test operation to check that the remote controller functions properly, and also explain the operation and cleaning procedures to the customer in accordance with the details in instruction manual. Furthermore, ask the customer to keep this installation manual and the instruction manual in a safe place for later reference.

### 10.6.1. Accessories supplied with wired remote controller

Name	Q'ty	Diagram	Remark
Remote controller	1		
Remote control cable	1		Length (10m)
4mm screw	3		Installing the remote controller to the wall
M4 screw	3		Installing the remote controller to an outlet box
Round terminal	2		Connecting to indoor unit terminal block

### 10.6.2. Notes regarding wired remote controller setting-up location

- Select a place where the remote controller can be operated easily (after obtaining approval from the building's owner).
- Install in a place which is away from direct sunlight and as free from humidity as possible.
- Install in a place which is as flat as possible to avoid warping of the remote controller.  
(If installed to a wall an uneven surface, damage to the LCD case or operation problems may result.)
- Install in a place where the LCD can be seen easily. If the remote controller is installed somewhere which is too low or too high, it may be difficult to read the LCD. (Standard height from the floor is 1.2 to 1.5 meters.)
- Avoid installing the remote control cable near refrigerant pipes or drain pipes.
- Install the remote control cable at least 5cm away from other electric wires (including stereo and TV cables) to avoid mis-operation (electromagnetic noise).
- If passing the remote control cable through a wall, be sure to install a water trap above the cable.
- Allow sufficient space around the remote controller as shown in the illustration at right.  
Secure the remote controller lower case to the wall or to an outlet.

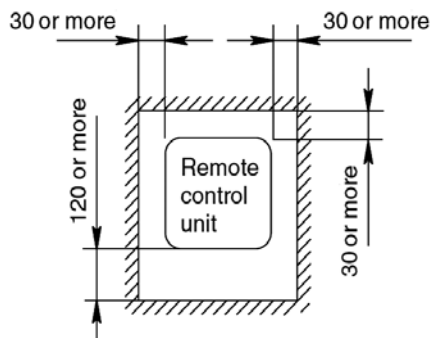

### 10.6.3. Remote controller installation

- Be sure to turn off the main power before installing and connecting the remote controller.  
(If the remote controller is connected while the power is still turned on, the remote controller displays may not appear.)  
If no displays appear on the remote controller, check while referring to “If no remote controller displays appear” in “5 Test operation”.
- The remote control cable is live during use, so please be careful with it.

### Remote controller wiring

- Connect the indoor unit and the remote controller as shown in the illustration below.
- The remote control cable is non-polar.
- At the time of shipment from the factory, the connector cable used to connect the terminal block and connector CN1 is disconnected. When connecting the remote controller wiring and installing the remote controller, be sure to connect the cord to the connector CN1.

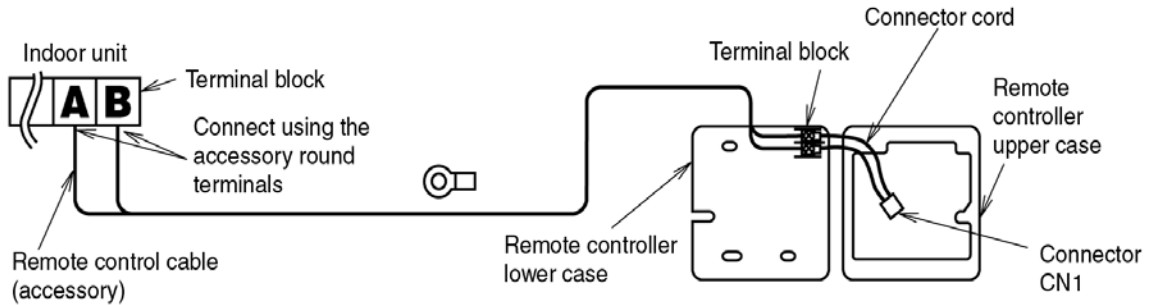

### Extending the remote control cable

- Solder a sheathed PVC cord or cable (0.5 - 2 mm<sup>2</sup>) with specifications among those given below to the remote controller end of the accessory remote control cable (10 m).

- |   |           |
|---|-----------|
| * PVC round cable cord                        | IEC 502   |
| * 600V PVC-insulated PVC sheathed round cable | IEC 227-4 |
| * 600V PVC-insulated PVC sheathed flat cable  | IEC 227-4 |

**NOTE** The maximum possible length for the remote control cable is 200 m.

### Remote controller installation procedure

- Remove the remote controller lower case.  
(Insert a flat-tipped screw driver or similar 2 to 3 mm into one of the gaps at the bottom of the case, and then twist the screw driver to open. [Refer to the illustration below.])  
Be careful not to damage the lower case.

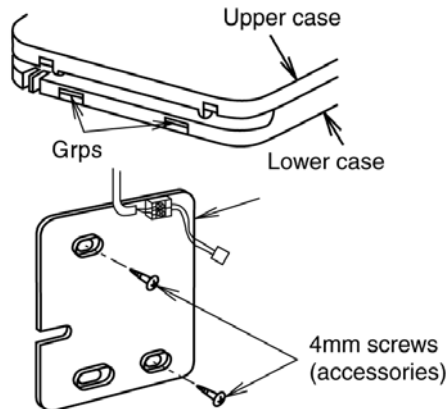

- Secure the lower case to the wall or outlet box.  
(Refer to the illustration at right for the embedded and exposed positions for remote control cable.)

#### **NOTE**

- Be sure to use only the accessory screws.
- Do not bend the lower case when tightening the screws.  
(If the screws are overtightened, damage may result.)
- Do not remove the protective tape which is affixed to the upper case circuit board.

- If installing the remote controller with the remote control cable exposed, use pliers to cut a notch into the upper case. (The feeding-out direction can be either up or to the left or right)
- Strip the end of the remote control cable which is to be connected to the remote controller. (Refer to the illustration below)

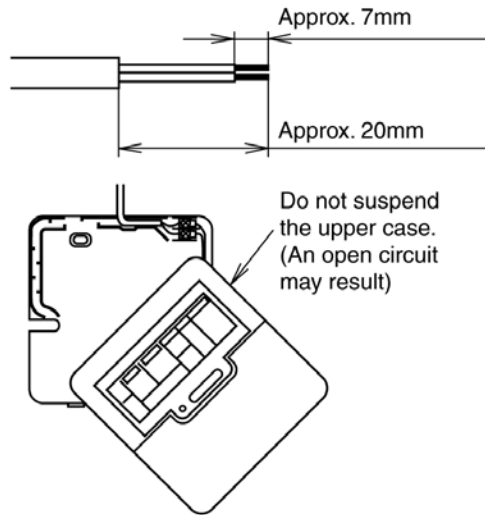

- Route the remote control cable inside the lower case in accordance with the intended feeding-out direction. (Refer to the illustration below.)
- Securely connect connector CN1. (If it is not connected the remote controller will not operate.)

**NOTE** After connecting the connector, do not suspend the upper case by its own weight, otherwise the connector cord may break.

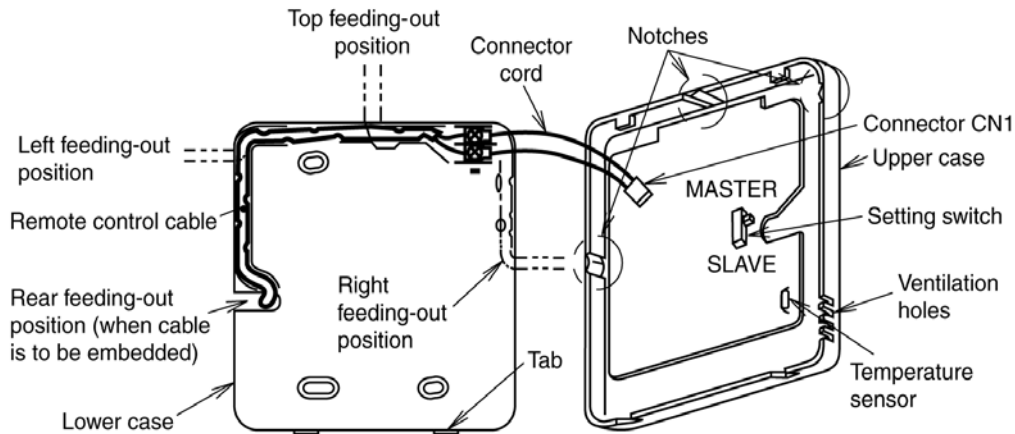

- If controlling using two remote controllers, refer to "Control using two remote controllers" in "4 Settings".
- Secure the upper case to the lower case.  
(Hook the upper tab of the upper case into the lower case, and then push the upper case until it snaps shut onto the lower case tab, while being careful not to clamp the remote control cable and the connector cord.)

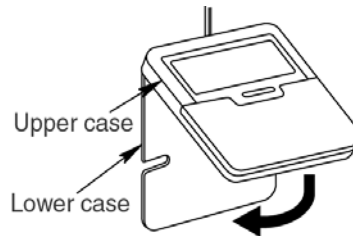

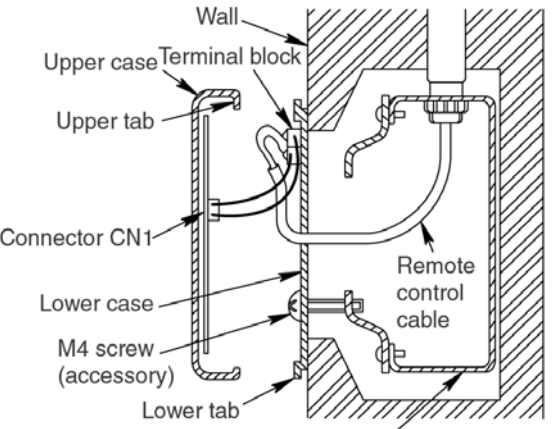
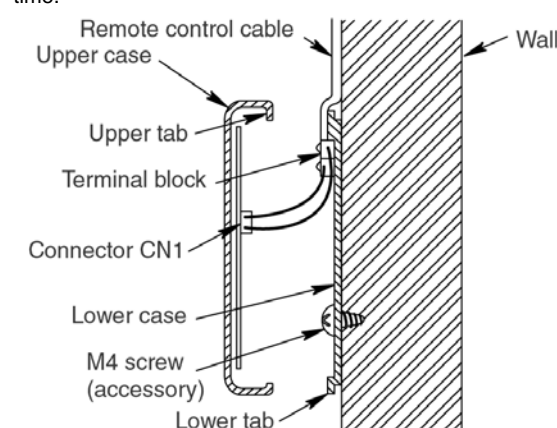

If remote control cable is embedded	If installing with the remote control cable exposed
<p>1. Embed an outlet box (JIS C 8336) into the wall, and then secure the remote controller base plate to the outlet box with the two accessory M4 screws. Make sure that the base plate is flat against the wall at this time, with no bending (looseness)</p> <p>2. Pass the remote control cable into the box and then install the remote controller.</p>  <p>Medium-sized square outlet box (JIS C 8336) (obtain locally) Part No. DS3744 (Matsushita Electric Industrial Co., Ltd.) or equivalent</p>	<p>1. Secure the remote controller base plate to the wall with two accessory 4 mm screws.</p> <p>2. The feeding-out direction for the remote control cable can be either up or to the left or right. (Refer to the illustration above.) After determining the feeding-out direction, use nippers to make a notch in the cover.</p> <p>3. Route the remote control cable as shown in the illustration above. Pull the cord firmly around the outside of the base plate at this time.</p> 

## 10.6.4. Settings

### Control using two remote controllers

- Up to two remote controllers can be installed for a single indoor unit, and either remote controller can be used to operate the indoor unit.
- The indoor unit can be operated with the last switch pressed having priority.
  - Decide which is to be the master and which is to be the slave remote controller.
 

The master or slave states of the remote controller are set automatically. The MASTER/SLAVE setting switch can also be used to make the setting manually, however if a manual setting is made, that manual setting has priority. Be sure to turn off the main power before making a manual setting.
  - Connect the remote controllers.
 

Connect both remote controller to terminals (A) and (B) on the indoor unit terminal block (non-polar).

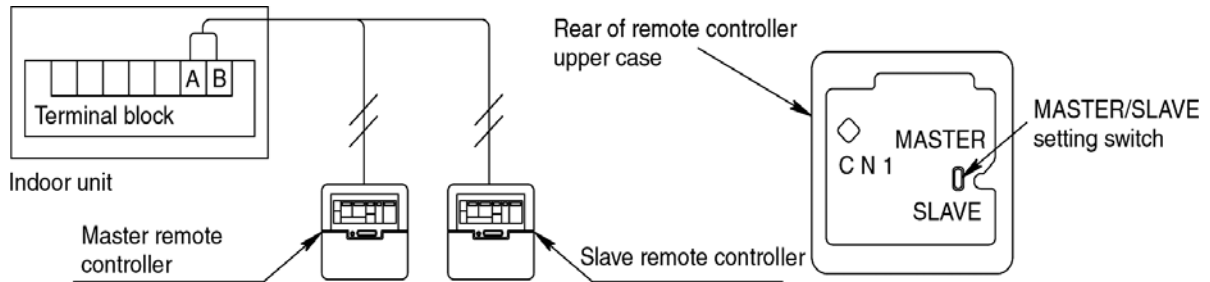

### Group control

- All in group will be remote controller thermistor setting when using the remote controller thermistor.
- Up to a maximum of 16 indoor units can be connected at the time of group control. (Do not connect heat pump unit with cooling only unit.)
- Indoor unit No. is possible to set automatically at the time of group control. However, what number would be assigned to which indoor units is unknown.
 

Indoor unit No. is also possible to set manually with DIP switches. Since manual address setting is priority during performing automatic address setting. (Do not use manual address setting and automatic address setting together.)

Indoor unit No.	1	2	3	4	5	6	7	8
DIP switch (SW2) address setting on indoor unit printed circuit board.								
A/C No. setting	Unnecessary operation	1 - ON	2 - ON	1, 2 - ON	3 - ON	1, 3 - ON	2, 3 - ON	1, 2, 3 - ON
Indoor unit No.	9	10	11	12	13	14	15	16
DIP switch (SW2) address setting on indoor unit printed circuit board.								
A/C No. setting	4 - ON	1, 4 - ON	2, 4 - ON	1, 2, 4 - ON	3, 4 - ON	1, 3, 4 - ON	2, 3, 4 - ON	1, 2, 3, 4 - ON

Automatic address resetting for group control

- The address settings for group control (air conditioner Nos. 1 to 16) can be reset automatically.
  - When operation is stopped, press for 5 seconds, continue the TEST RUN switch to display "00" (will be LOCAL MODE).
  - Press the UP (TEMP) DOWN (TEMP) switch to display 10.
  - Press the SELECT switch to display "000". It would blink.
  - Press the UP (TIMER) DOWN (TIMER) switch to display "001". It would blink.
  - Press the SET switch.

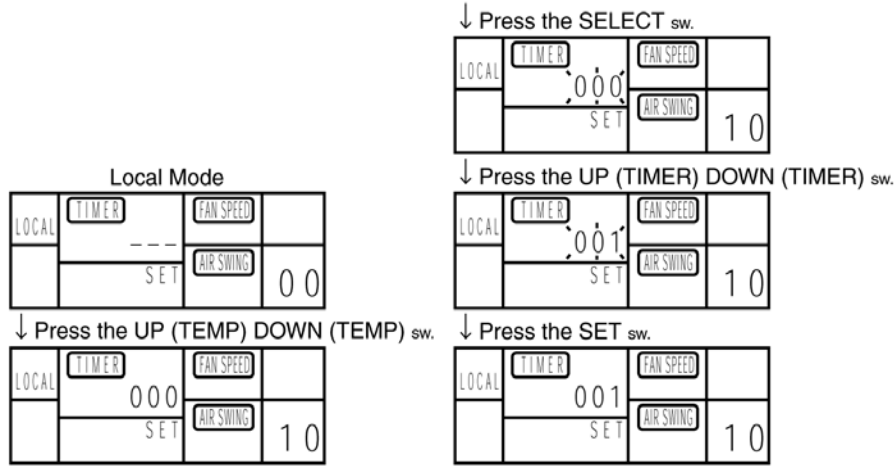

Switching the thermistor

- The temperature detection thermistor can be switched between the thermistor at the indoor unit and the thermistor at the remote controller. However, do not switch to the remote controller thermistor if using two remote controllers.
  - When operation is stopped, press for 5 seconds, continue the TEST RUN switch to display "00" (will be LOCAL MODE).
  - Press the UP (TEMP) DOWN (TEMP) switch to display 11.
  - Press the SELECT switch to display "000". It would blink.
  - Press the UP (TIMER) DOWN (TIMER) switch to choose display "000" or "001".
    - "000"... Indoor unit setting (factory default)
    - "001"... Remote controller setting
  - Press the SET switch. (Be sure to press the SET switch so that normal operation mode can be resumed.)
- Repeat the procedure in steps (1) to (5) to change the setting again.

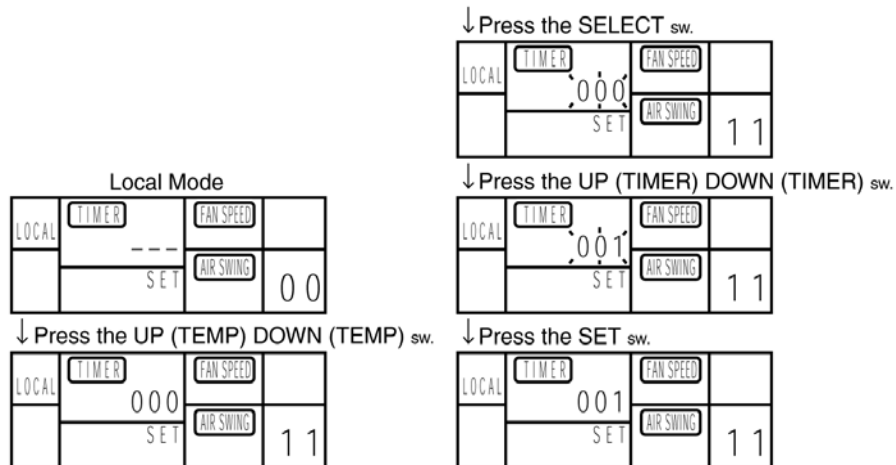

## 10.6.5. Test operation

- Turn on the main power.
- After 3 minutes have passed since the power was turned on, press the OFF/ON switch on the remote controller. (No operation occurs within 3 minutes after the power was turned on.)
- Press the TEST RUN switch within 1 minute of pressing the OFF/ON switch.
- Next, select the operation mode. (Be sure to select cooling mode first, and run the unit in this mode for 5 minutes or more.)
- Press the OFF/ON switch or the TEST RUN switch to cancel test operation.
- Test operation will be cancelled automatically after 30 minutes.



If remote controller displays nothing

- Check once more that the remote control cable is securely connected. (Check for loose terminals, poor contacts, connection positions terminal block, etc.)
- If the above checks show that nothing is wrong but nothing appears on the remote controller display.
- It is possible that the remote controller was connected while the main power was still turned on. If such is the case, carry out the following.
- Set DIP switch (SW2) No. 1 to 4. The ON position, and then turn on the main power. If the display appears after about 30 seconds, turn DIP switches 2 to 4 to OFF position.

## 10.6.6. Self-diagnosis function

If "CHECK" is blinking on the timer

- If the "CHECK" display on the wired remote controller is blinking, the details of the problems are displayed on the timer display screen each time the CHECK switch is pressed.
- Further details of the problem can be displayed by pressing the SET switch while the general problem details are being displayed.

Example of current problem display

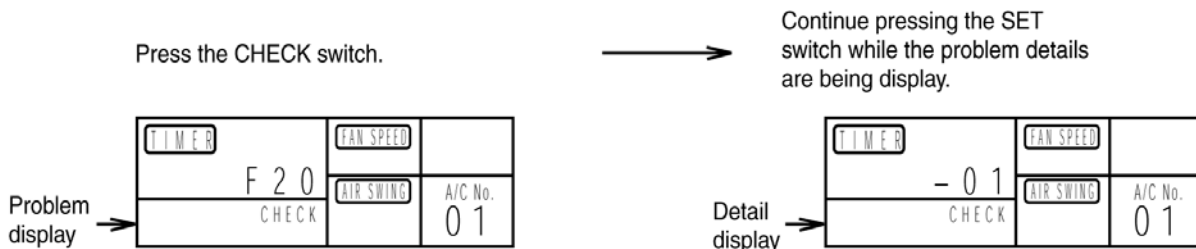

If "CHECK" is not blinking on the timer

- If the "CHECK" display on the wired remote controller is not blinking, press the CHECK switch continuously for 5 seconds or more to display the problem details for the last problem or the problem before that.
- You can then switch between the display for the previous problem and the problem before that by pressing the UP (TIMER) DOWN (TIMER) switches.
- Press the CHECK switch once more to return to the normal display.

Example of previous problem display

Press the CHECK switch for 5 seconds or more.

Problem display →

TIMER	FAN SPEED	
1 F 2 0	AIR SWING	A/C No.
CHECK		0 1



Continue pressing the SET switch while the problem details are being display.

Detail display →

TIMER	FAN SPEED	
1 - 0 1	AIR SWING	A/C No.
CHECK		0 1

Example of abnormality display before previous display

While the previous display still appears, press the UP (TIMER) DOWN (TIMER) switch.

Problem display →

TIMER	FAN SPEED	
2 F 2 0	AIR SWING	A/C No.
CHECK		0 1



Continue pressing the SET switch while the problem details are being display.

Detail display →

TIMER	FAN SPEED	
2 - 0 1	AIR SWING	A/C No.
CHECK		0 1

- The display can be switched between the previous problem and the one before that by pressing the UP (TIMER) DOWN (TIMER) switches.
- After eliminating the cause of the problem, press the CHECK switch once more to return to the normal display.

## 10.7. Wireless remote control installation manual

### Wireless Remote Control Installation Manual

- Before installing the wireless remote controller, be sure to thoroughly read the “Notes with regard to safety” section of the installation manual provided with the indoor unit.
- After installing the wireless remote controller, carry out a test operation to check that the remote controller functions properly, and also explain the operation and cleaning procedures to the customer in accordance with the details in the instruction manual. Furthermore, ask the customer to keep this installation manual and the instruction manual in a safe place for later reference.

#### 10.7.1. Accessories supplied with the wireless remote controller

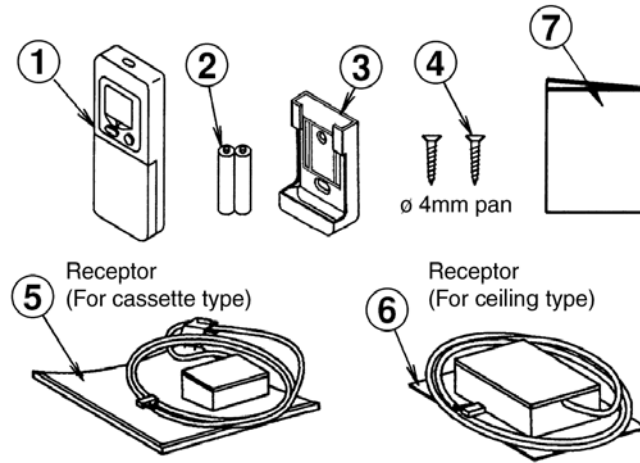

No.	Name	Q'ty	
		Cassette	Ceiling
1.	Wireless Remote Controller	1	1
2.	R03 battery	2	2
3.	Holder (For securing remote controller)	1	1
4.	Holder fixing screw	2	2
5.	Receptor unit (For Cassette Type)	1	-
6.	Receptor unit (For Ceiling Type)	-	1
7.	Installation manual	1	1

#### 10.7.2. Points and notes regarding wireless remote controller setting-up location

- The wireless remote controller can be used to operate indoor units at a maximum range of 8 metres from directly facing in front of the indoor unit.
- If the remote controller is at an angle to the receptor unit, the operation range may become shortened.
- The accessory receptor unit must be attached to the veneer panel.
- The receptor unit for the wireless remote controller should be in a place where it will not be affected by direct light from fluorescent lights. (Refer to the illustration below.)

(If using an inverter-type fluorescent light, keep the receptor unit at least 1m away from the light, otherwise remote control operation may not work properly.)

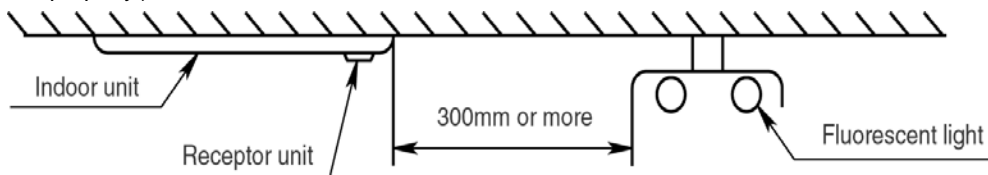

- If installing in a place where a power supply is generating electromagnetic noise, take measures such as installing a noise filter.
- Install at least 3m away from any noise sources, and shield the electric cables using an iron conduit pipe.
- Install at least 1m away from equipment such as TVs and radios. (Otherwise picture distortion or static may occur.)

## Wireless remote control installation procedure

- Installing the wireless remote controller to a wall (for remote control storage).

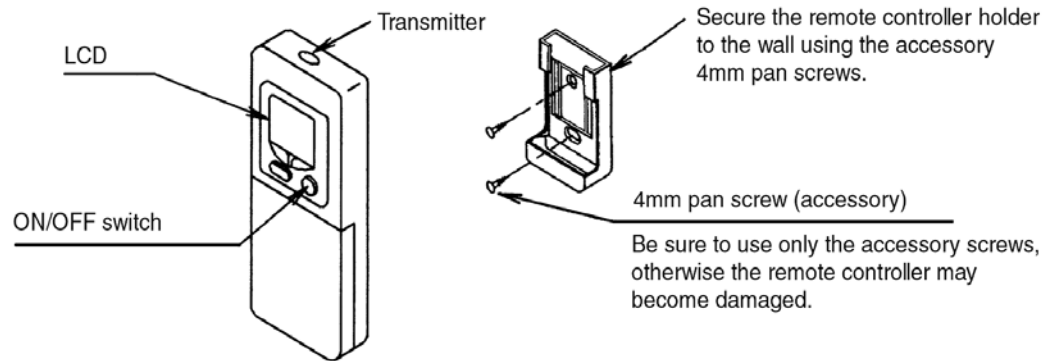

- If using a single remote controller to operate several air conditioners, address setting will be required. (Refer to later in this manual.)
- For twin and triple types, install to the main unit only. (Accordingly, the installation and wiring operations described later in this manual are for the main unit only.)

## Inserting the batteries

- Remove the battery compartment cover of the wireless remote controller, and then insert the two accessory R03 size batteries. (Be sure not to make a mistake with the polarities.)

### NOTE

The accessory batteries are to be used when checking operation. They should be replaced with new batteries as soon as possible. (Be sure not to make a mistake with the polarities.)

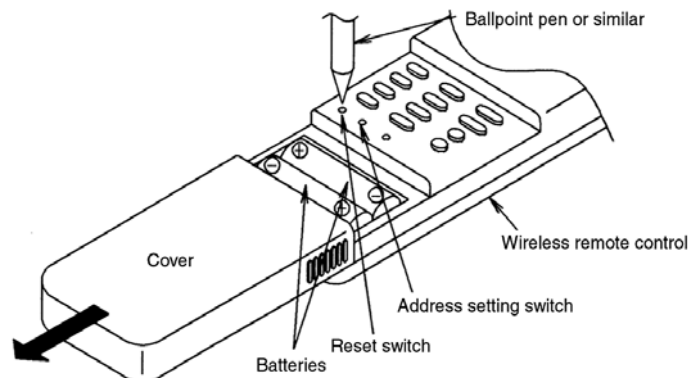

### NOTE

- When inserting the batteries for the first time, or when replacing the batteries, the remote controller may stop working. In such case, use a ballpoint pen or similar object to push the reset switch. The remote controller should then start working normally.
- Replace the batteries with two new batteries of the same kind.
- Rechargeable (Ni-Cd) batteries differ in aspects such as shape and performance, and thus cannot be used.

## 10.7.3. Installing the receptor unit

### Receptor unit (for four-way cassette type) assembly procedure

1 Attach the receptor unit onto the decorative panel of the indoor unit as shown in the figure below.

1. Remove the "corner cover" at the decorative panel indicate "Panasonic" logo left side.
2. Attach the receptor unit which same position.

2 Route the joint cord for wiring and connect it to P.C.B connector <CN-DISP> in the control box of the indoor unit.

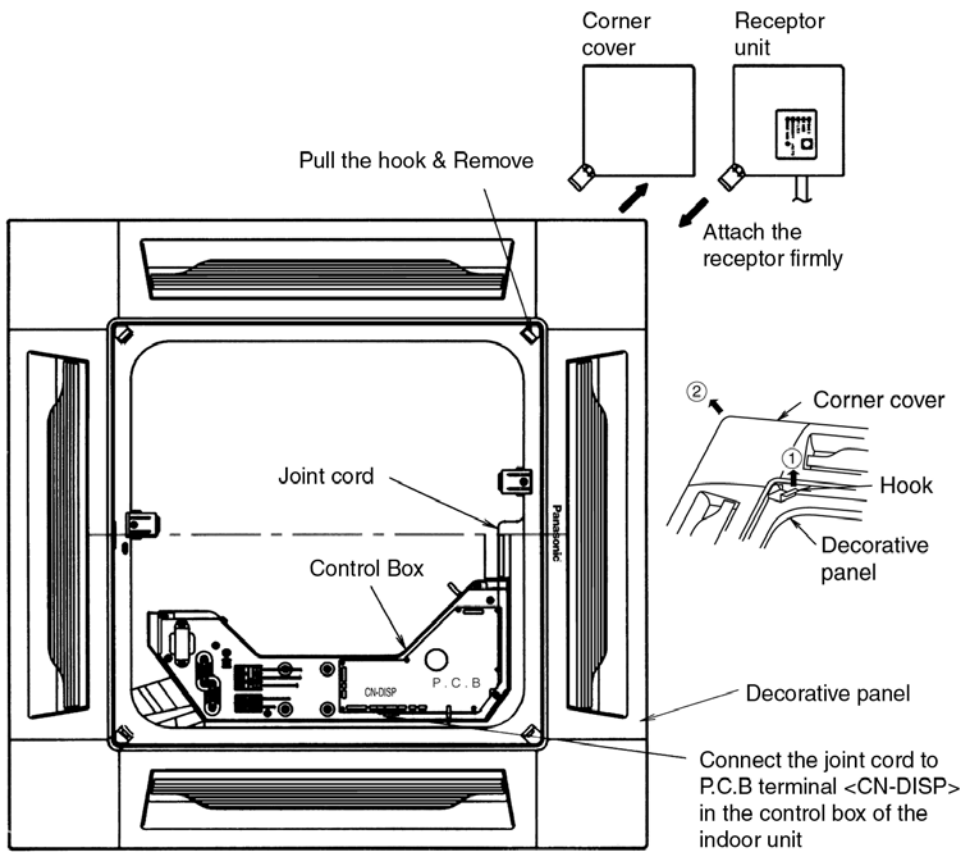

1. Route the joint cord for wiring as shown in the figure (figure of the back of decorative panel) below.  
Pass the cord through the hook of the decorative panel, taking care that the cord does not run on the heat insulator, etc.

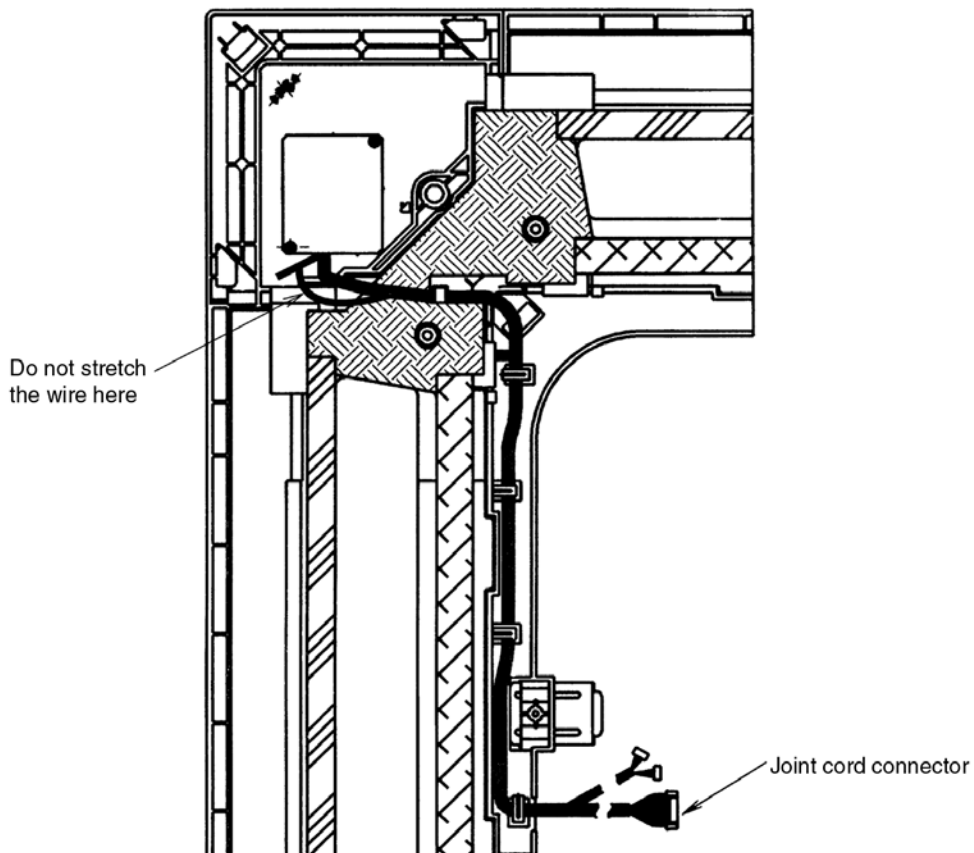

2. Remove the control box cover by removing the two fixing screws and connect the joint cord to P.C.B terminal <CN-DISP> in the control box.



## Receptor unit (for ceiling type) assembly procedure

1	Attach the receptor unit onto the indoor main unit as shown in the figure below.
---	--

1. Remove the air-intake grille and the side cover.  
To remove the side cover, remove the fixing screw each on the left and the right and pull the side cover towards you.  
(Refer to the installation Manual supplied with the indoor main unit.)

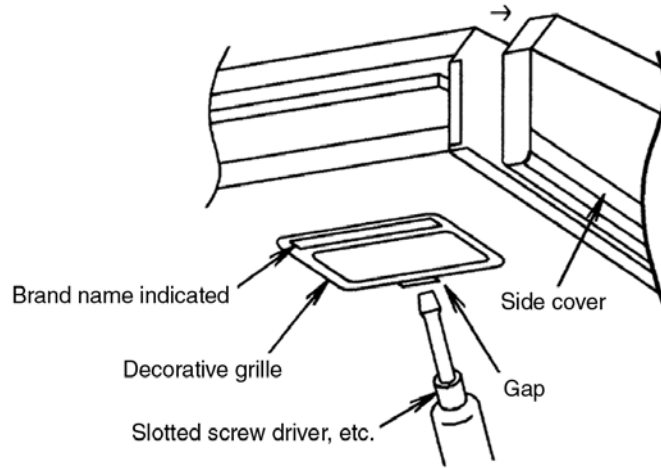

2. Remove the Decorative grille (component on which the brand name is shown) to the right on the air-blow opening. (Fixed with three tabs.)  
(There is a gap at the rear center of the decorative grille. Insert the tip of a slotted screwdriver, etc., 2 to 3mm into the gap and pry of the decorative grille to remove.)
3. Draw out the cord of the receptor unit through the feed-through hole toward the side plate and attach the receptor unit onto the main unit.  
Hook the three tabs onto the receptor unit to attach the receptor unit on the main unit. (Press in the receptor unit until a click sound is heard.)

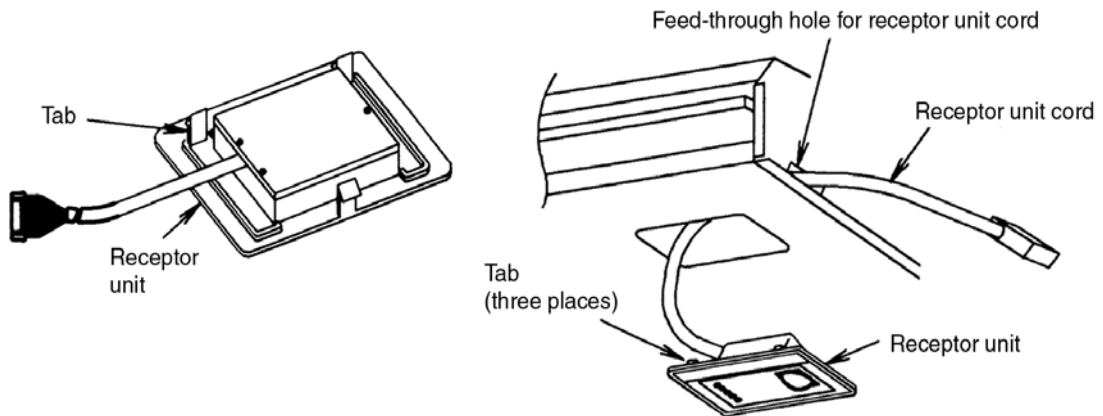

2 Route the joint cord for wiring and connect it to P.C.B terminal <CN-DISP> in the control box of the indoor unit.

1. Route for wiring the cord as shown in the figure to the right.
2. Remove the control box cover by removing the two fixing screws and connect the joint cord to P.C.B terminal <CN-DISP> in the control box.

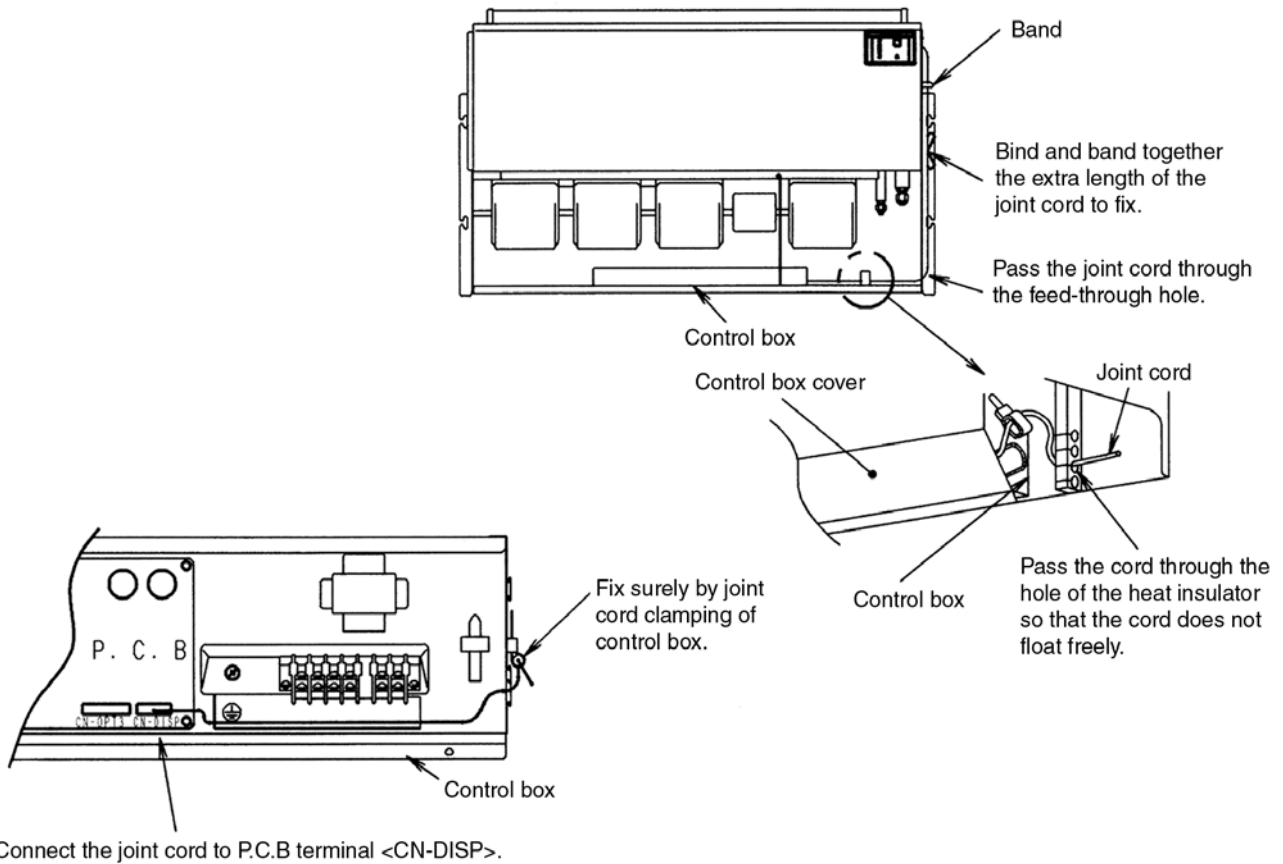

#### 10.7.4. Address setting for wireless remote controller and receptor unit (only when using more than one indoor unit)

- Only the air conditioner units which receptor unit address numbers match the remote controller address number can be operated.
- At the time of shipment from the factory, the address numbers for both the wireless remote controller and the receptor unit are set to "1". (When using only one indoor unit, the indoor unit can be used without changing the factory default settings.)

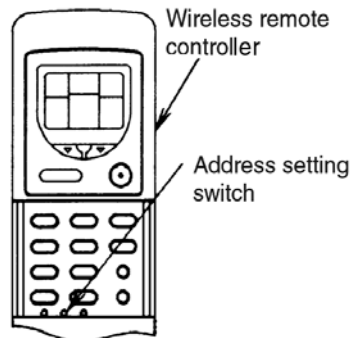

Press the address setting switch with a ballpoint pen or similar object to change the address setting.

The address number displayed on the LCD change in the order [ADDRESS 1] → [ADDRESS 2] → [ADDRESS 3] → [GROUP] → [ADDRESS 1] each time the switch is pressed.

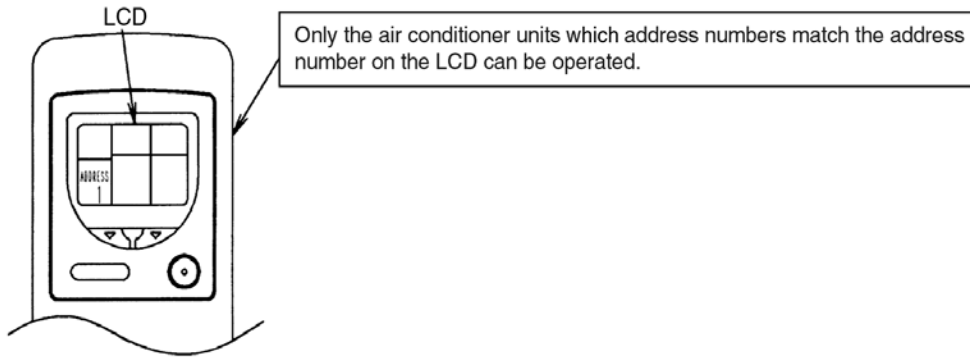

**NOTE**

- If the batteries are replaced or the remote controller is reset, the address setting will return to ADDRESS1, so you will need to repeat the address setting again.  
All setting details which are stored in memory will be cleared, so you will need to repeat the setting.
- If the address is set to GROUP, more than one indoor unit can be operated at the same time.

**Example:** If the address numbers for all indoor units are changed, other indoor units may operate accidentally due to signal interference.

**Control using two remote controllers**

- If both the wireless remote controller and the optional wired remote controller are being used together, either remote controller can be used to operate the indoor units.
- The optional wired remote controller can be connected to only one other indoor unit besides the one with the receptor unit.
- Two wireless remote controller cannot be connected at the same time.
- When using the wireless remote controller and the optional wired remote controller, the MASTER/SLAVE setting is not needed.

**Group control**

- When using group control, be sure to install the receptor unit to indoor unit No. 1. (Refer to the illustration below.)

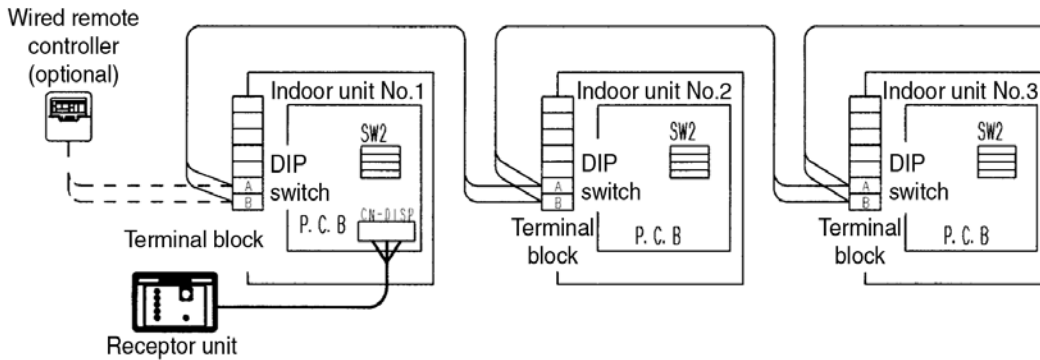

- When using group control, up to a maximum of 16 indoor units can be connected. (Do not mix heat pump units and cooling only units.)
- When using group control, the indoor unit address numbers can be set automatically. However, you will not know at this time which address number corresponds to which indoor unit.
- Setting of address numbers can be carried out manually using the DIP switches. Manual settings have priority. (Do not combine both manual settings and automatic settings.)

**[Manual setting]**

Indoor unit No.	1	2	3	4	5	6	7	8
DIP switch (SW2) address setting on indoor unit printed circuit board.								
A/C No. setting	Unnecessary operation	1 ~ ON	2 ~ ON	1, 2 ~ ON	3 ~ ON	1, 3 ~ ON	2, 3 ~ ON	1, 2, 3 ~ ON
Indoor unit No.	9	10	11	12	13	14	15	16
DIP switch (SW2) address setting on indoor unit printed circuit board.								
A/C No. setting	4 ~ ON	1, 4 ~ ON	2, 4 ~ ON	1, 2, 4 ~ ON	3, 4 ~ ON	1, 3, 4 ~ ON	2, 3, 4 ~ ON	1, 2, 3, 4 ~ ON

**10.7.5. Emergency operation**

- If you do not have the wireless remote controller (because the batteries are weak, or some other reason prevents the wireless remote controller from being used), emergency operation can be carried out at receptor unit.

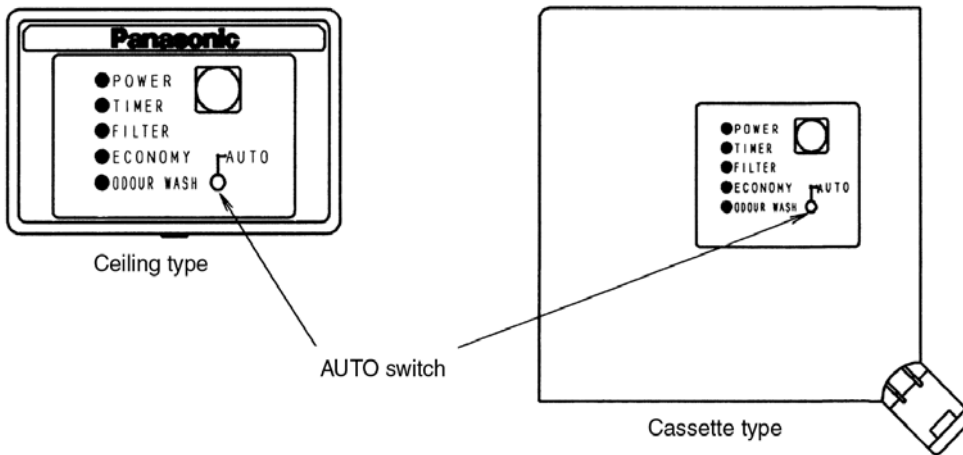

- Press the AUTO switch to start emergency operation.  
Press the AUTO switch once more to stop emergency operation.
- Press the AUTO switch continue 5 seconds to start cooling operation.  
Again press the AUTO switch continue 5 seconds to start heating operation.
- The setting temperature, fan speed and louver control will be fixed at the settings shown in the table below.
- While the indoor unit is running, the OPERATION indicator on the receptor unit will illuminate, and it will switch off when the indoor units stops.
- Heating operation is not available for indoor units which are for cooling only. (If set to HEAT, the setting will change to FAN instead.)

Operation mode	Fan speed	Louver
Cooling	Hi	Previous setting
Heating	Hi	Previous setting

Instructions for users

Please refer to the instruction manual provided with the indoor unit for instruction on how to use the wireless remote controller.

# 11 Installation and Servicing Air Conditioner Using R410A

## 11.1. Outline

### 11.1.1. About R410A refrigerant

#### 1. Converting air conditioners to R410A

Since it was declared in 1974 that chlorofluorocarbons (CFC), hydro chlorofluorocarbons (HCFC) and other substances pose a destructive danger to the ozone layer in the earth's upper stratosphere (20 to 40 km above the earth), measures have been taken around the world to prevent this destruction.

The R22 refrigerant which has conventionally been used in ACs is an HCFC refrigerant and, therefore, possesses this ozone-destroying potential. International regulations (the Montreal Protocol on Ozone-Damaging Substances) and the domestic laws of various countries call for the early substitution of R22 by a refrigerant which will not harm the ozone layer.

- In ACs, the HFC refrigerant which has become the mainstream alternative is called R410A. Compared with R22, the pressure of R410A is approximately 1.6 times as high at the same refrigerant temperature, but the energy efficiency is about the same. Consisting of hydrogen (H), fluorine (F) and carbon (C), R410A is an HFC refrigerant. Another typical HFC refrigerant is R407C. While the energy efficiency of R407C is somewhat inferior to that of R410A, it offers the advantage of having pressure characteristics which are about the same as those of R22, and is used mainly in packaged ACs.

#### 2. The characteristics of HFC (R410A) refrigerants

##### a. Chemical characteristics

The chemical characteristics of R410A are similar to those of R22 in that both are chemically stable, non-flammable refrigerants with low toxicity.

However, just like R22, the specific gravity of R410A gas is heavier than that of air. Because of this, it can cause an oxygen deficiency if it leaks into a closed room since it collects in the lower area of the room. It also generates toxic gas when it is directly exposed to a flame, so it must be used in a well ventilated environment where it will not collect.

Table 1 Physical comparison of R410A and R22

	R410A	R22
Composition (wt%)	R32/R125 (50/50)	R22 (100)
Boiling point (°C)	-51.4	-40.8
Vaporizing pressure (25°C)	1.56 MPa (15.9 kgf/cm <sup>2</sup> )	0.94 MPa (9.6 kgf/cm <sup>2</sup> )
Saturated vapor density	64.0 kg/m <sup>3</sup>	44.4 kg/m <sup>3</sup>
Flammability	Non-flammable	Non-flammable
Ozone-destroying point (ODP)	0	0.055
Global-warming point (GWP)	1730	1700

##### b. Compositional change (pseudo-azeotropic characteristics)

R410A is a pseudo-azeotropic mixture comprising the two components R32 and R125. Multi-component refrigerants with these chemical characteristics exhibit little compositional change even from phase changes due to vaporization (or condensation), which means that there is little change in the circulating refrigerant composition even when the refrigerant leaks from the gaseous section of the piping.

Accordingly, R410A can be handled in almost the same manner as the single-component refrigerant R22. However, when charging, because there is a slight change in composition between the gas phase and the liquid phase inside a cylinder or other container, charging should basically begin with the liquid side.

##### c. Pressure characteristics

As seen in Table 2, the gas pressure of R410A is approximately 1.6 times as high as that of R22 at the same refrigerant temperature, which means that special R410A tools and materials with high-pressure specifications must be used for all refrigerant piping work and servicing.

Table 2 Comparison of R410A and R22 saturated vapor density

Unit: MPa

Refrigerant Temperature (°C)	R410A	R22
-20	0.30	0.14
0	0.70	0.40
20	1.35	0.81
40	2.32	1.43
60	3.73	2.33
65	4.15	2.60

d. R410A refrigerating machine oil

Conventionally, mineral oil or a synthetic oil such as alkylbenzene has been used for R22 refrigerating machine oil. Because of the poor compatibility between R410A and conventional oils like mineral oil, however, there is a tendency for the refrigerating machine oil to collect in the refrigerating cycle. For this reason, polyester and other synthetic oils which have a high compatibility with R410A are used as refrigerating machine oil.

Because of the high hygroscopic property of synthetic oil, more care must be taken in its handling than was necessary with conventional refrigerating machine oils. Also, these synthetic oils will degrade if mixed with mineral oil or alkylbenzene, causing clogging in capillary tubes or compressor malfunction. Do not mix them under any circumstances.

### 11.1.2. Safety measures when installing/servicing refrigerant piping

Cause the gas pressure of R410A is approximately 1.6 times as high as that of R22, a mistake in installation or servicing could result in a major accident. It is essential that you use R410A tools and materials, and that you observe the following precautions to ensure safety.

1. Do not use any refrigerant other than R410A in ACs that have been used with R410A.
2. If any refrigerant gas leaks while you are working, ventilate the room. Toxic gas may be generated if refrigerant gas is exposed to a direct flame.
3. When installing or transferring an AC, do not allow any air or substance other than R410A to mix into the refrigeration cycle. If it does, the pressure in the refrigeration cycle can become abnormally high, possibly causing an explosion and/or injury.
4. After finishing the installation, check to make sure there is no refrigerant gas leaking.
5. When installing or transferring an AC, follow the instructions in the installation instructions carefully. Incorrect installation can result in an abnormal refrigeration cycle or water leakage, electric shock, fire, etc.
6. Do not perform any alterations on the AC unit under any circumstances. Have all repair work done by a specialist. Incorrect repairs can result in a water leakage, electric shock, fire, etc.

## 11.2. Tools for installing/servicing refrigerant piping

### 11.2.1. Necessary tools

In order to prevent an R410A AC from mistakenly being charged with any other refrigerant, the diameter of the 3-way valve service port on the outdoor unit has been changed. Also, to increase its ability to withstand pressure, the opposing dimensions have been changed for the refrigerant pipe flaring size and flare nut. Accordingly, when installing or servicing refrigerant piping, you must have both the R410A and ordinary tools listed below.

Table 3 Tools for installation, transferring or replacement

Type of work	Ordinary tools	R410A tools
Flaring	Flaring tool (clutch type), pipe cutter, reamer	Copper pipe gauge for clearance Adjustment, flaring tool (clutch type)*1)
Bending, connecting pipes	Torque wrench (nominal diameter 1/4, 3/8, 1/2). Fixed spanner (opposing sides 12 mm, 17 mm, 19 mm). Adjustable wrench, Spring bender	
Air purging	Vacuum pump. Hexagonal wrench (opposing sides 4 mm)	Manifold gauge, charging hose, vacuum pump adaptor
Gas leak inspection	Gas leak inspection fluid or soapy water	Electric gas leak detector for HFC refrigerant*2)

\*1) You can use the conventional (R22) flaring tool. If you need to buy a new tool, buy the R410A type.

\*2) Use when it is necessary to detect small gas leaks.

For other installation work, you should have the usual tools, such as screwdrivers (+,-), a metal-cutting saw, an electrical drill, a hole core drill (65 or 70 dia.), a tape measure, a level, a thermometer, a clamp meter, an insulation tester, a voltmeter, etc.

Table 4 Tools for serving

Type of work	Ordinary tools	R410A tools
Refrigerant charging		Electronic scale for refrigerant charging. Refrigerant cylinder. Charging orifice and packing for refrigerant cylinder
Brazing (Replacing refrigerating cycle part*1)	Nitrogen blow set (be sure to use nitrogen blowing for all brazing), and brazing machine	

\*1) Always replace the dryer of the outdoor unit at the same time. The replacement dryer is wrapped in a vacuum pack. Replace it last among the refrigerating cycle parts. Start brazing as soon as you have opened the vacuum pack, and begin the vacuuming operation within 2 hours.

## 11.2.2. R410A tools

1. Copper tube gauge for clearance adjustment  
(used when flaring with the conventional flaring tool (clutch type))
  - This gauge makes it easy to set the clearance for the copper tube to 1.0-1.5 mm from the clamp bar of the flaring tool.

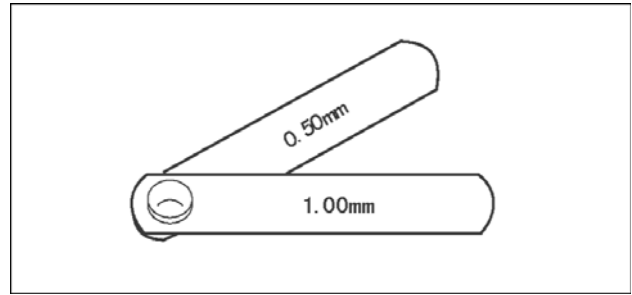

Fig. 1 Copper tube gauge for clearance adjustment

2. Flaring tool (clutch type)
  - In the R410A flaring tool, the receiving hole for the clamp bar is enlarged so the clearance from the clamp bar can be set to 0-0.5 mm, and the spring inside the tool is strengthened to increase the strength of the pipe-expanding torque. This flaring tools can also be used with R22 piping, so we recommend that you select it if you are buying a new flaring tool.

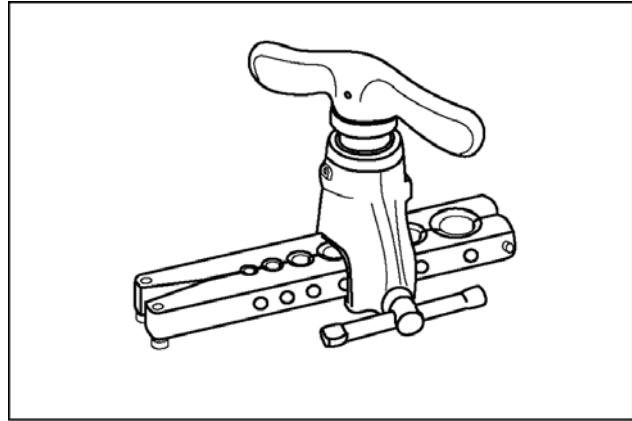

Fig. 2 Flaring tool (clutch type)

3. Torque wrenches

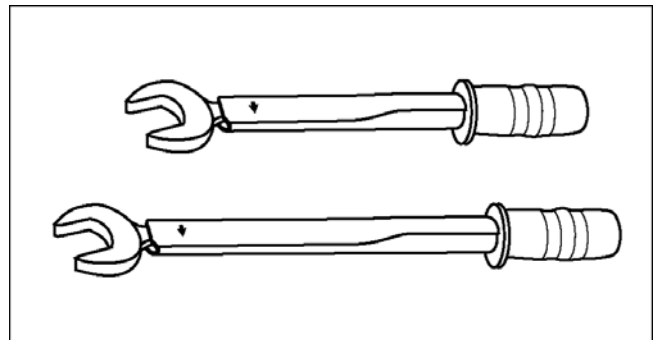

Fig. 3 Torque wrenches

Table 5

	Conventional wrenches	R410A wrenches
For 1/4 (opposite side x torque)	17 mm x 18 N.m (180 kgf.cm)	17 mm x 18 N.m (180 kgf.cm)
For 3/8 (opposite side x torque)	22 mm x 42 N.m (420 kgf.cm)	22 mm x 42 N.m (420 kgf.cm)
For 1/2 (opposite side x torque)	24 mm x 55 N.m (550 kgf.cm)	26 mm x 55 N.m (550 kgf.cm)
For 5/8 (opposite side x torque)	27 mm x 65 N.m (650 kgf.cm)	29 mm x 65 N.m (650 kgf.cm)

4. Manifold gauge

- Because the pressure is higher for the R410A type, the conventional type cannot be used.

Table 6 Difference between R410A and conventional high/low-pressure gauges

	Conventional gauges	R410A gauges
High-pressure gauge (red)	-76 cmHg - 35 kgf/cm <sup>3</sup>	-0.1 - 5.3 MPa -76 cmHg - 53 kgf/cm <sup>3</sup>
Low-pressure gauge (blue)	-76 cmHg - 17 kgf/cm <sup>3</sup>	-0.1 - 3.8 MPa -76 cmHg - 38 kgf/cm <sup>3</sup>

- The shape of the manifold ports has been changed to prevent the possibility of mistakenly charging with another type of refrigerant.

Table 7 Difference between R410A and conventional manifold port size

	Conventional gauges	R410A gauges
Port size	7/16 UNF 20 threads	1/2 UNF 20 threads

### 5. Charging hose

- The pressure resistance of the charging hose has been raised to match the higher pressure of R410A. The hose material has also been changed to suit HFC use, and the size of the fitting has been changed to match the manifold ports.

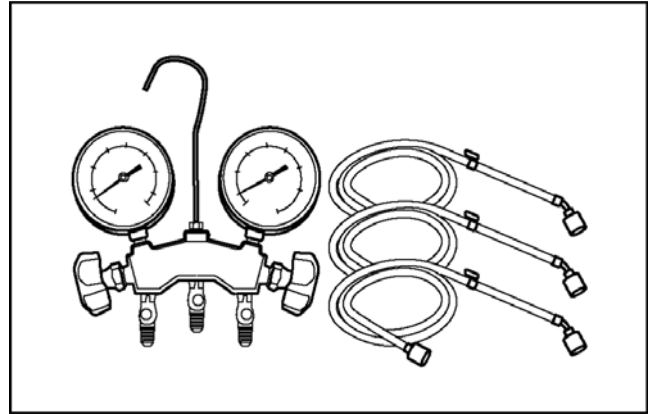

Fig. 4 Manifold gauge charging hose

Table 8 Difference between R410A and conventional charging hoses

		Conventional hoses	R410A hoses
Pressure resistance	Working pressure	3.4 MPa (35 kgf/cm <sup>3</sup> )	5.1 MPa (52 kgf/cm <sup>3</sup> )
	Bursting pressure	17.2 MPa (175 kgf/cm <sup>3</sup> )	27.4 MPa (280 kgf/cm <sup>3</sup> )
Material		NBR rubber	HNBR rubber Nylon coating inside

### 6. Vacuum pump adaptor

- When using a vacuum pump for R410A, it is necessary to install an electromagnetic valve to prevent the vacuum pump oil from flowing back into the charging hose. The vacuum pump adaptor is installed for that purpose. If the vacuum pump oil (mineral oil) becomes mixed with R410A, it will damage the unit.

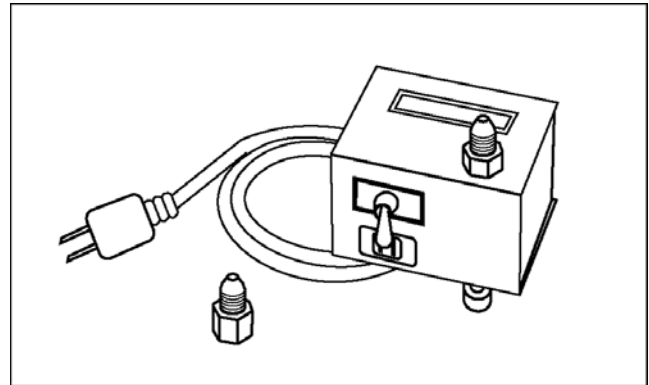

Fig. 5 Vacuum pump adaptor

### 7. Electric gas leak detector for HFC refrigerant

- The leak detector and halide torch that were used with CFC and HCFC cannot be used with R410A (because there is no chlorine in the refrigerant).
- The present R134a leak detector can be used, but the detection sensitivity will be lower (setting the sensitivity for R134a at 1, the level for R410A will drop to 0.6).
- For detecting small amounts of gas leakage, use the electric gas leak detector for HFC refrigerant. (Detection sensitivity with R410A is about 23 g/year).

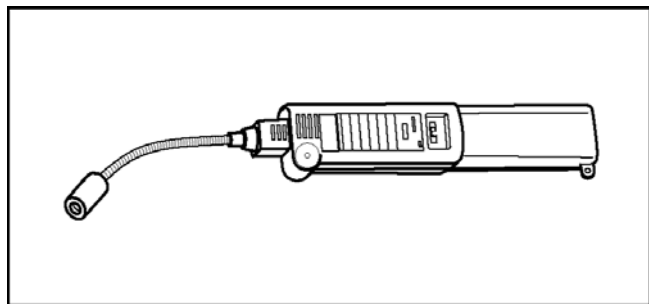

Fig. 6 Electric gas leak detector for HFC refrigerant



8. Electronic scale for refrigerant charging

- Because of the high pressure and fast vaporizing speed of R410A, the refrigerant cannot be held in a liquid phase inside the charging cylinder when charging is done using the charging cylinder method, causing bubbles to form in the measurement scale glass and making it difficult to see the reading. (Naturally, the conventional R22 charging cylinder cannot be used because of the differences in the pressure resistance, scale gradation, connecting port size, etc.)
- The electronic scale has been strengthened by using a structure in which the weight detector for the refrigerant cylinder is held by four supports. It is also equipped with two connection ports, one for R22 (7/16 UNF, 20 threads) and one for R410A (1/2 UNF, 20 threads), so it can also be used for conventional refrigerant charging.
- There are two types of electronic scales, one for 10-kg cylinders and one for 20-kg cylinders. (The 10-kg cylinder is recommended.)  
Refrigerant charging is done manually by opening and closing the valve.

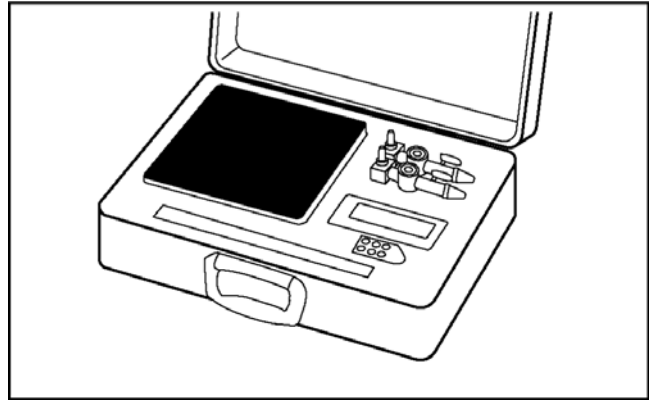

Fig. 7 Electronic scale for refrigerant charging

9. Refrigerant cylinders

- The R410A cylinders are labeled with the refrigerant name, and the coating color of the cylinder protector is pink, which is the color stipulated by ARI of the U.S.
- Cylinders equipped with a siphon tube are available to allow the cylinder to stand upright for liquid refrigerant charging.

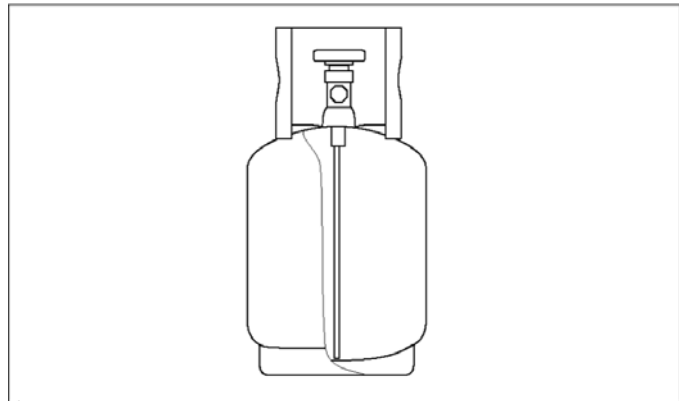

Fig. 8 Refrigerant cylinders

10. Charging orifice and packing for refrigerant cylinders

- The charging orifice must match the size of the charging hose fitting (1/2 UNF, 20 threads).
- The packing must also be made of an HFC-resistant material.

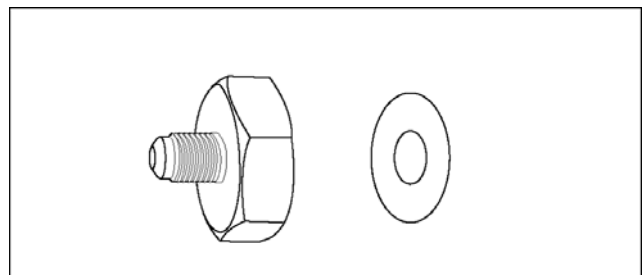

Fig. 9 Charging orifice and packing

11.2.3. R410A tools which are usable for R22 models

Table 9 R410A tools which are usable for R22 models

	R410A tools	Usable for R22 models
(1)	Copper tube gauge for clearance adjustment	OK
(2)	Flaring tool (clutch type)	OK
(3)	Manifold gauge	NG
(4)	Charging hose	NG
(5)	Vacuum pump adaptor	OK
(6)	Electric gas leak detector for HFC refrigerant	NG
(7)	Electronic scale for refrigerant charging	OK
(8)	Refrigerant cylinder	NG
(9)	Charging orifice and packing for refrigerant cylinder	NG

## 11.3. Refrigerant piping work

### 11.3.1. Piping materials

It is recommended that you use copper and copper alloy jointless pipes with a maximum oil adherence of 40 mg/10m. Do not use pipes that are crushed, deformed, or discolored (especially the inside surface). If these inferior pipes are used, impurities may clog the expansion valves or capillaries.

Because the pressure of ACs using R410A is higher than those using R22, it is essential that you select materials that are appropriate for these standards.

The thickness of the copper tubing used for R410A is shown in Table 10. Please be aware that tubing with a thickness of only 0.7 mm is also available on the market, but this should never be used.

Table 10 Copper tube thickness (mm)

Soft pipe		Thickness (mm)	
Nominal diameter	Outside diameter (mm)	R410A	(Reference) R22
1/4	6.35	0.80	0.80
3/8	9.52	0.80	0.80
1/2	12.7	0.80	0.80
5/8	15.88	1.00	1.00

### 11.3.2. Processing and connecting piping materials

When working with refrigerant piping, the following points must be carefully observed: no moisture or dust must be allowed to enter the piping, and there must be no refrigerant leaks.

#### 1. Procedure and precautions for flaring work

##### a. Cut the pipe

Use a pipe cutter, and cut slowly so the pipe will not be deformed.

##### b. Remove burrs and clean shavings from the cut surface

If the shape of the pipe end is poor after removing burrs, or if shavings adhere to the flared area, it may lead to refrigerant leaks.

To prevent this, turn the cut surface downward and remove burrs, then clean the surface, carefully.

##### c. Insert the flare nut (be sure to use the same nut that is used on the AC unit)

##### d. Flaring

Check the clamp bar and the cleanliness of the copper pipe.

Be sure to use the clamp bar to do the flaring with accuracy. Use either an R410A flaring tool, or a conventional flaring tool. Flaring tools come in different sizes, so be sure to check the size before using. When using a conventional flaring tool, use the copper pipe gauge for clearance adjustment, etc., to ensure the correct A dimension (see Fig. 10)

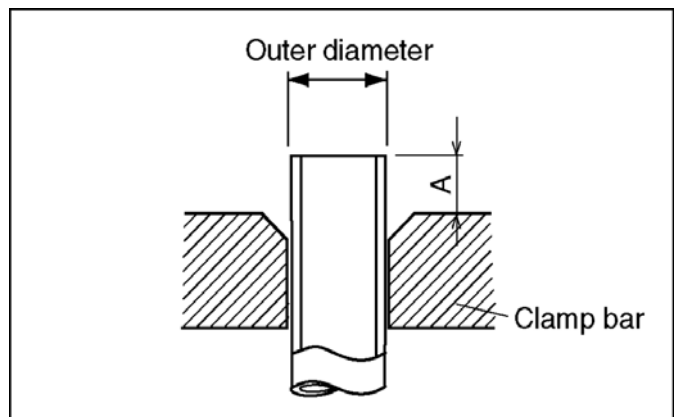

Fig. 10 Flaring dimensions

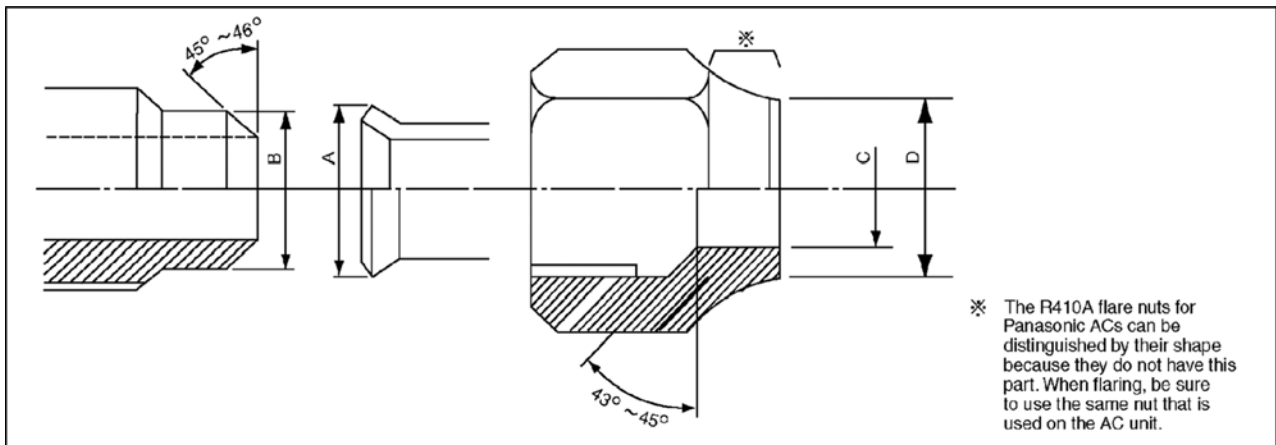

Fig. 11 Relation between the flare nut structure and flaring tool end

Table 11 R410A flaring dimensions

Nominal diameter	Outside diameter (mm)	Wall thickness (mm)	A (mm)		
			R410A flaring tool, clutch type	Conventional flaring tool	
				Clutch type	Wing-nut type
1/4	6.35	0.8	0 - 0.5	1.0 - 1.5	1.5 - 2.0
3/8	9.52	0.8	0 - 0.5	1.0 - 1.5	1.5 - 2.0
1/2	12.70	0.8	0 - 0.5	1.0 - 1.5	2.0 - 2.5
5/8	15.88	1.0	0 - 0.5	1.0 - 1.5	2.0 - 2.5

Table 12 R22 flaring dimensions

Nominal diameter	Outside diameter (mm)	Wall thickness (mm)	A (mm)		
			R22 flaring tool, clutch type	Conventional flaring tool	
				Clutch type	Wing-nut type
1/4	6.35	0.8	0 - 0.5	0.5 - 1.0	1.0 - 1.5
3/8	9.52	0.8	0 - 0.5	0.5 - 1.0	1.0 - 1.5
1/2	12.70	0.8	0 - 0.5	0.5 - 1.0	1.5 - 2.0

Table 13 R410A flare and flare nut dimensions Unit: mm

Nominal diameter	Outside diameter (mm)	Wall thickness (mm)	A +0, -0.4	B dimension	C dimension	D dimension	Flare nut width
1/4	6.35	0.8	9.1	9.2	6.5	13	17
3/8	9.52	0.8	13.2	13.5	9.7	20	22
1/2	12.70	0.8	16.6	16.0	12.9	23	26
5/8	15.88	1.0	19.7	19.0	16.0	25	29

Table 14 R22 flare and flare nut dimensions Unit: mm

Nominal diameter	Outside diameter (mm)	Wall thickness (mm)	A +0, -0.4	B dimension	C dimension	D dimension	Flare nut width
1/4	6.35	0.8	9.0	9.2	6.5	13	17
3/8	9.52	0.8	13.0	13.5	9.7	20	22
1/2	12.70	0.8	16.2	16.0	12.9	20	24

2. Procedure and precautions for flare connection

- a. Check to make sure there is no scratches, dust, etc., on the flare and union.
- b. Align the flared surface with the axial center of the union.
- c. Use a torque wrench, and tighten to the specified torque. The tightening torque for R410A is the same as the conventional torque value for R22. Be careful, because if the torque is too weak, it may lead to a gas leak. If it is too strong, it may split the flare nut or make it impossible to remove the flare nut.

Table 15 R410A tightening torque

Nominal diameter	Outside diameter (mm)	Tightening torque N.m (kgf.cm)	Torque wrench tightening torque N.m (kgf.cm)
1/4	6.35	14 - 18 (140 - 180)	18 (180)
3/8	9.52	33 - 42 (330 -420)	42 (420)
1/2	12.70	55 (550)	55 (550)
5/8	15.88	65 (650)	65 (650)

11.3.3. Storing and managing piping materials

1. Types of piping and their storage

The following is a general classification of the refrigerant pipe materials used for ACs.

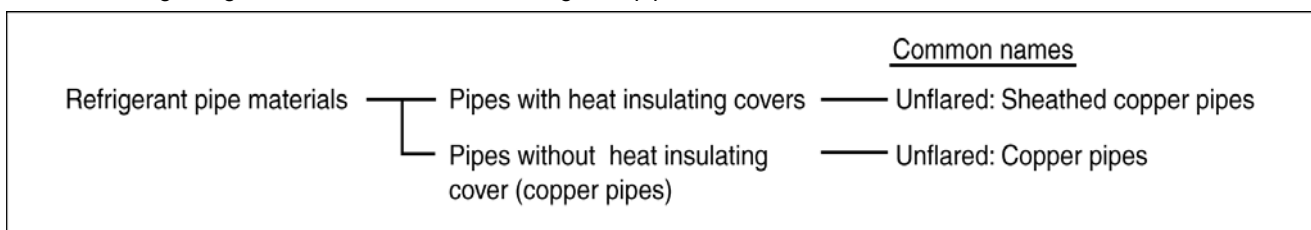

Because the gas pressure of R410A is approximately 1.6 times as high as that of R22, copper pipes with the thickness shown in Table 10, and with minimal impurities must be used. Care must also be taken during storage to ensure that pipes are not crushed, deformed, or scratched, and that no dust, moisture or other substance enters the pipe interior. When storing sheathed copper pipes or plain copper pipes, seal the openings by pinching or taping them securely.

2. Makings and management

- a. Sheathed copper pipes and copper-element pipes

When using these pipes, check to make sure that they are the stipulated thickness. For flare nuts, be sure to use the same nut that is used on the AC unit.

b. Copper pipes

Use only copper pipes with the thickness given in table 10, and with minimal impurities. Because the surface of the pipe is exposed, you should take special care, and also take measures such as marking the pipes to make sure they are easily distinguished from other piping materials, to prevent mistaken use.

3. Precautions during refrigerant piping work

Take the following precautions on-site when connecting pipes. (Keep in mind that the need to control the entry of moisture and dust is even more important than in conventional piping).

- a. Keep the open ends of all pipes sealed until connection with AC equipment is complete.
- b. Take special care when doing piping work on rainy days. The entering of moisture will degrade the refrigerating machine oil, and lead to malfunctions in the equipment.
- c. Complete all pipe connections in as short a time as possible. If the pipe must be left standing for a long time after removing the seal, it must be thoroughly purged with nitrogen, or dried with a vacuum pump.

## 11.4. Installation, transferring, servicing

### 11.4.1. Inspecting gas leaks with a vacuum pump for new installations (Using new refrigerant piping)

1. From the viewpoint of protecting the global environment, please do not release refrigerant into the atmosphere.
  - a. Connect the projecting side (pin-pushing side) of the charging hose for the manifold gauge to the service port of the 3-way valve. (1)
  - b. Fully open the handle Lo of the manifold gauge and run the vacuum pump. (2) (If the needle of the low-pressure gauge instantly reaches vacuum, re-check step a.)
  - c. Continue the vacuum process for at least 15 minutes, then check to make sure the low-pressure gauge has reached -0.1 MPa (-76 cmHg). Once the vacuum process has finished, fully close the handle Lo of the manifold gauge and stop the vacuum pump operation, then remove the charging hose that is connected to the vacuum pump adaptor. (Leave the unit in that condition for 1-2 minutes, and make sure that the needle of the manifold gauge does not return.) (2) and (3)
  - d. Turn the valve stem of the 2-way valve 90° counter-clockwise to open it, then, after 10 seconds, close it and inspect for a gas leak (4)
  - e. Remove the charging hose from the 3-way valve service port, then open both the 2-way valve and 3-way valve. (1) (4) (Turn the valve stem in the counter-clockwise direction until it gently makes contact. Do not turn it forcefully).
  - f. Tighten the service port cap with a torque wrench (18 N.m (1.8 kgf.m)). (5) Then tighten the 2-way valve and 3-way valve caps with a torque wrench (42 N.m (4.2 kgf.m)) or (55 N.m (5.5 kgf.m)). (6)
  - g. After attaching each of the caps, inspect for a gas leak around the cap area. (5) (6)

#### Precautions

- Be sure to read the instructions for the vacuum pump, vacuum pump adaptor and manifold gauge prior to use, and follow the instructions carefully.
- Make sure that the vacuum pump is filled with oil up to the designated line on the oil gauge.
- The gas pressure back flow prevention valve on the charging hose is generally open during use. When you are removing the charging hose from the service port, it will come off more easily if you close this valve.

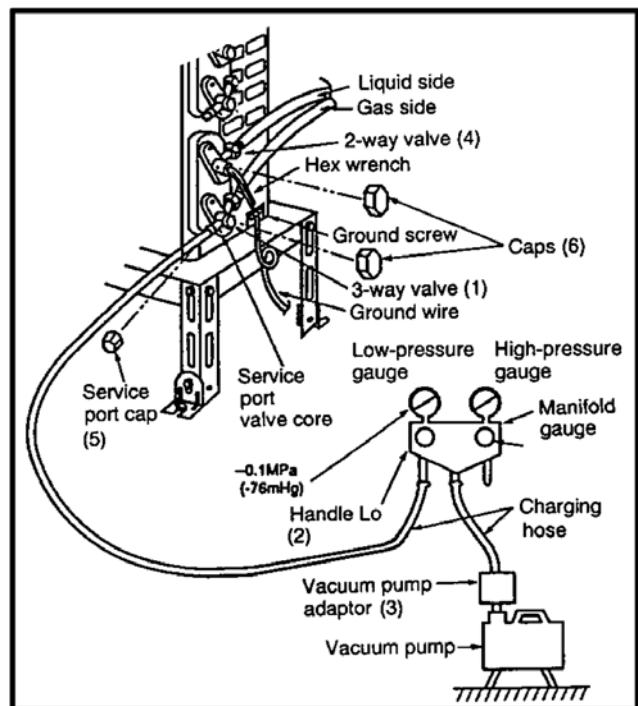

Fig. 12 Vacuum pump air purging configuration

## 11.4.2. Transferring (Using new refrigerant piping)

### 1. Removing the unit

#### a. Collecting the refrigerant into the outdoor unit by pumping down

The refrigerant can be collected into the outdoor unit (pumping down) by pressing the TEST RUN button, even when the temperature of the room is low.

- Check to make sure that the valve stems of the 2-way valve and 3-way valve have been opened by turning them counter-clockwise. (Remove the valve stem caps and check to see that the valve stems are fully opened position. Always use a hex wrench (with 4-mm opposing sides) to operate the valve stems.)
- Press the TEST RUN button on the indoor unit, and allow preliminary operation for 5-6 minutes. (TEST RUN mode)
- After stopping the operation, let the unit sit for about 3 minutes, then close the 2-way valve by turning the valve stem in the clockwise direction.
- Press the TEST RUN button on the indoor unit again, and after 2-3 minutes of operation, turn the valve stem of the 3-way valve quickly in the clockwise direction to close it, then stop the operation.
- Tighten the caps of the 2-way valve and 3-way valve to the stipulated torque.
- Remove the connection pipes (liquid side and gas side).

#### b. Removing the indoor and outdoor units

- Disconnect the pipes and connecting electric cables from between the indoor and outdoor units.
- Put capped flare nuts onto all of the pipe connections of the indoor and outdoor units, to make sure no dust or other foreign matter enters.
- Remove the indoor and outdoor units.

### 2. Installing the unit

Install the unit using new refrigerant piping. Follow the instructions in section 4.1 to evacuate the pipes connecting the indoor and outdoor units, and the pipes of the indoor unit, and check for gas leaks.

## 11.4.3. AC units replacement (Using existing refrigerant piping)

When replacing an R410A AC unit with another R410A AC unit, you should re-flare the refrigerant piping. Even though the replacement AC unit uses the R410A, problems occur when, for example, either the AC unit maker or the refrigerating machine oil is different.

When replacing an R22 AC unit with an R410A AC unit, the following checks and cleaning procedures are necessary but are difficult to do because of the chemical characteristics of the refrigerating machine oil (as described in items c) and d) of section **About R410A Refrigerant**). In this case, you should use new refrigerant piping rather than the existing piping.

### 1. Piping check

Because of the different pressure characteristics of R22 and R410A, the design pressure for the equipment is 1.6 times different. The wall thickness of the piping must comply with that shown in Table 10, but this is not easy to check. Also, even if the thickness is correct, there may be flattened or bent portions midway through the piping due to sharp curves. Buried sections of the piping also cannot be checked.

### 2. Pipe cleaning

A large quantity of refrigerating machine oil (mineral oil) adheres to existing pipes due to the refrigeration cycle circulation. If the pipes are used just as they are for the R410A cycle, the capacity will be lowered due to the incompatibility of this oil with the R410A, or irregularities may occur in the refrigeration cycle. For this reason, the piping must be thoroughly cleaned, but this is difficult with the present technology.

## 11.4.4. Refrigerant compatibility (Using R410A refrigerant in R22 ACs and vice versa)

Do not operate an existing R22 AC with the new R410A refrigerant. Doing so would result in improper functioning of the equipment or malfunction, and might lead to a major accident such as an explosion in the refrigeration cycle. Similarly, do not operate an R410A AC with R22 refrigerant. The chemical reaction between the refrigerating machine oil used in R410A ACs and the chlorine that is contained in R22 would cause the refrigerating machine oil to degrade and lead to malfunction.

## 11.4.5. Recharging refrigerant during servicing

When recharging is necessary, insert the specified amount of new refrigerant in accordance with the following procedure.

1. Connect the charging hose to the service port of the outdoor unit.
2. Connect the charging hose to the vacuum pump adaptor. At this time, fully open the 2-way valve and 3-way valve.
3. Fully open the handle Lo of the manifold gauge, turn on the power of the vacuum pump and continue the vacuum process for at least one hour.
4. Confirm that the low pressure gauge shows a reading of -0.1 MPa (-76 cmHg), then fully close the handle Lo, and turn off the vacuum pump. Wait for 1-2 minutes, then check to make sure that the needle of the Low pressure gauge has not returned. See Fig. 13 for the remaining steps of this procedure.
5. Set the refrigerant cylinder onto the electronic scale, then connect the hose the cylinder and to the connection port for the electronic scale. (1)(2)

**Precaution:**

Be sure to set up the cylinder for liquid charging. If you use a cylinder equipped with a siphon tube, you can charge the liquid without having to turn the cylinder around

6. Remove the charging hose of the manifold gauge from the vacuum pump adaptor, and connect it to the connection port of the electronic scale. (2)(3)
7. Open the valve of the refrigerant cylinder, then open the charging valve slightly and close it. Next, press the check valve of the manifold gauge and purge the air. (2)(4) (Watch the liquid refrigerant closely at this point.)
8. After adjusting the electronic scale to zero, open the charging valve, then open the valve Lo of the manifold gauge and charge with the liquid refrigerant. (2)(5) (Be sure to read the operating instructions for the electronic scale.)
9. If you cannot charge the stipulated amount, operate the unit in the cooling mode while charging a little of the liquid at a time (about 150 g/time as a guideline). If the charging amount is insufficient from one operation, wait about one minute, then use the same procedure to do the liquid charging again.

**Precaution:**

Never use the gas side to allow a larger amount of liquid refrigerant to be charged while operating the unit.

10. Close the charging valve, and after charging the liquid refrigerant inside the charging hose, fully close the valve Lo of the manifold gauge, and stop the operation of the unit. (2)(5)
11. Quickly remove the charging hose from the service port. (6) If you stop midway through, the refrigerant that is in the cycle will be discharged.
12. After putting on the caps for the service port and operating valve, inspect around the caps for a gas leak. (6)(7)

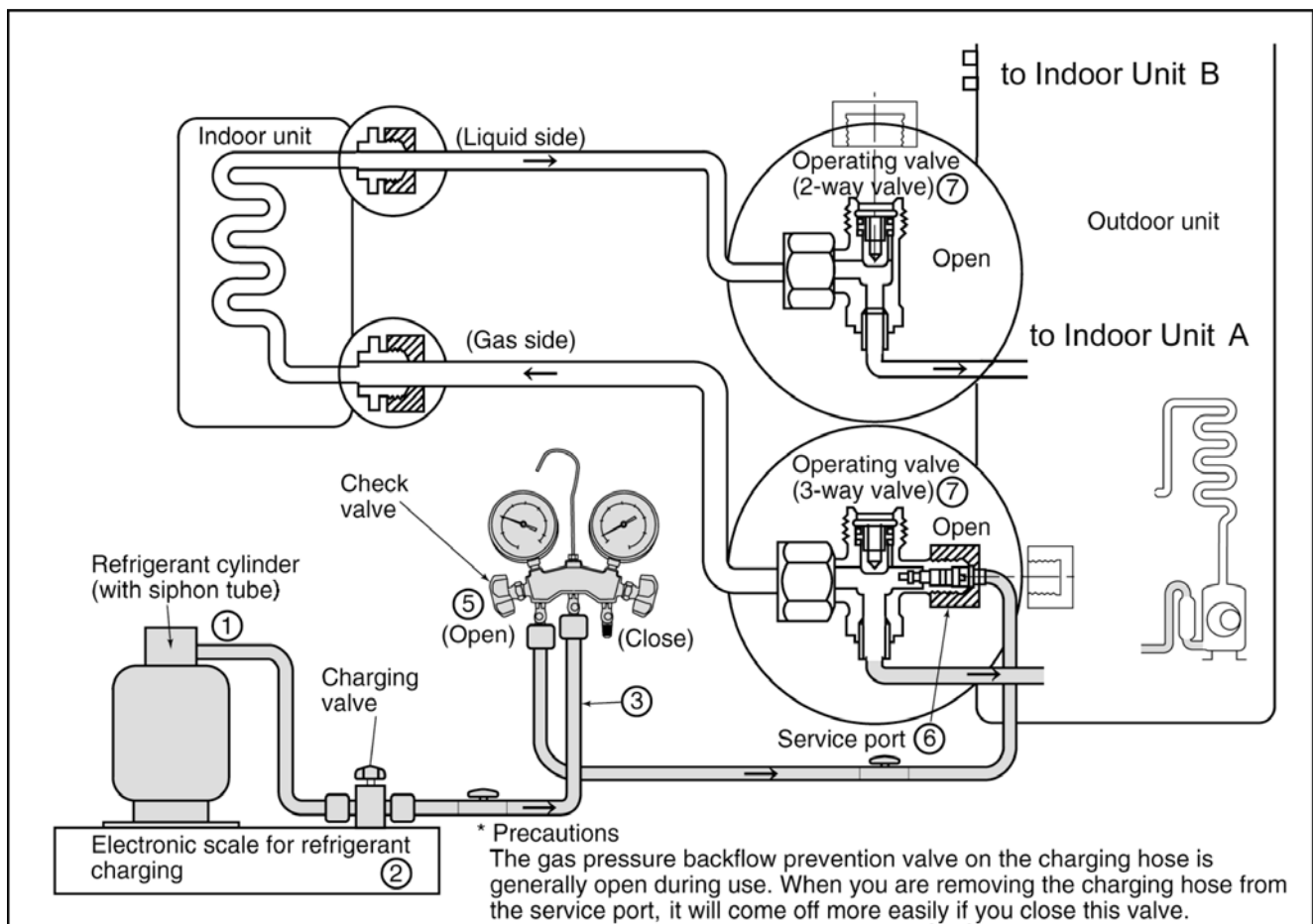

Fig. 13 Re-charging refrigerant

### 11.4.6. Brazing

As brazing requires sophisticated techniques and experiences, it must be performed by a qualified person.

In order to prevent the oxide film from occurring in the pipe interior during brazing, it is effective to proceed with brazing while letting dry nitrogen gas (N<sub>2</sub>) flow.

#### <Brazing Method for Preventing Oxidation>

1. Attach a reducing valve to the nitrogen gas cylinder.
2. Apply a seal onto the clearance between the piping and inserted pipe for the nitrogen gas in order to prevent the nitrogen gas from flowing backward.
3. When the nitrogen gas is flowing, be sure to keep the piping end open.
4. Adjust the flow rate of nitrogen gas so that it is lower than 0.05 m<sup>3</sup>/h, or 0.02 MPa (0.2 kgf/cm<sup>2</sup>) by means of the reducing valve.
5. After taking the steps above, keep the nitrogen gas flowing until the piping cools down to a certain extent (i.e. temperature at which pipes are touchable with finger).
6. Completely remove the flux after brazing.

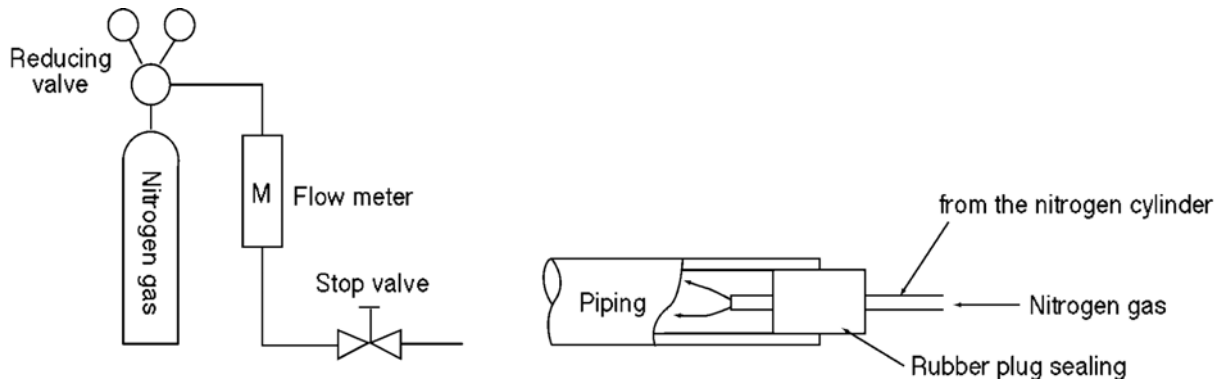

Fig. 14 Prevention of Oxidation during Brazing

#### Cautions during brazing

1. General Cautions
  - a. The brazing strength should be high as required.
  - b. After operation, airtightness should be kept under pressurized condition.
  - c. During brazing do not allow component materials to become damaged due to overheating.
  - d. The refrigerant pipe work should not become blocked with scale or flux.
  - e. The brazed part should not restrict the flow in the refrigerant circuit.
  - f. No corrosion should occur from the brazed part.

#### 2. Prevention of Overheating

Due to heating, the interior and exterior surfaces of treated metal may oxidize. Especially, when the interior of the refrigerant circuit oxidizes due to overheating, scale occurs and stays in the circuit as dust, thus exerting a fatally adverse effect. So, make brazing at adequate brazing temperature and with minimum of heating area.

#### 3. Overheating Protection

In order to prevent components near the brazed part from overheating damage or quality deterioration due to flame or heat, take adequate steps for protection such as (1) by shielding with a metal plate, (2) by using a wet cloth, and (3) by means of heat absorbent.

#### 4. Movement during Brazing

Eliminate all vibration during brazing to protect brazed joints from cracking and breakage.

#### 5. Oxidation Preventative

In order to improve the brazing efficiency, various types of antioxidant are available on the market. However, the constituents of these are widely varied, and some are anticipated to corrode the piping materials, or adversely affect HFC refrigerant, lubricating oil, etc. Exercise care when using an oxidation preventative.

### 11.4.7. Servicing tips

**The drier must also be replaced whenever replacing the refrigerant cycle parts. Replacing the refrigerant cycle parts first before replacing the drier. The drier is supplied in a vacuum pack. Perform brazing immediately after opening the vacuum pack, and then start the vacuum within two hours. In addition, the drier also needs to be replaced when the refrigerant has leaked completely. (Applicable for drier models only)**

# 12 Troubleshooting Guide

If test operation does not proceed correctly

Carry out test operation after approximately 12 hours have passed since the power was turned on (crankcase heater is energized). If operation is started by using the remote control within 1 minute of turning on the power, the outdoor unit settings will not be made correctly and correct operation will not be possible.

If the following symptoms occur after turning on the power, check the wiring connections once more.

## 12.1. For standard installation

### System example

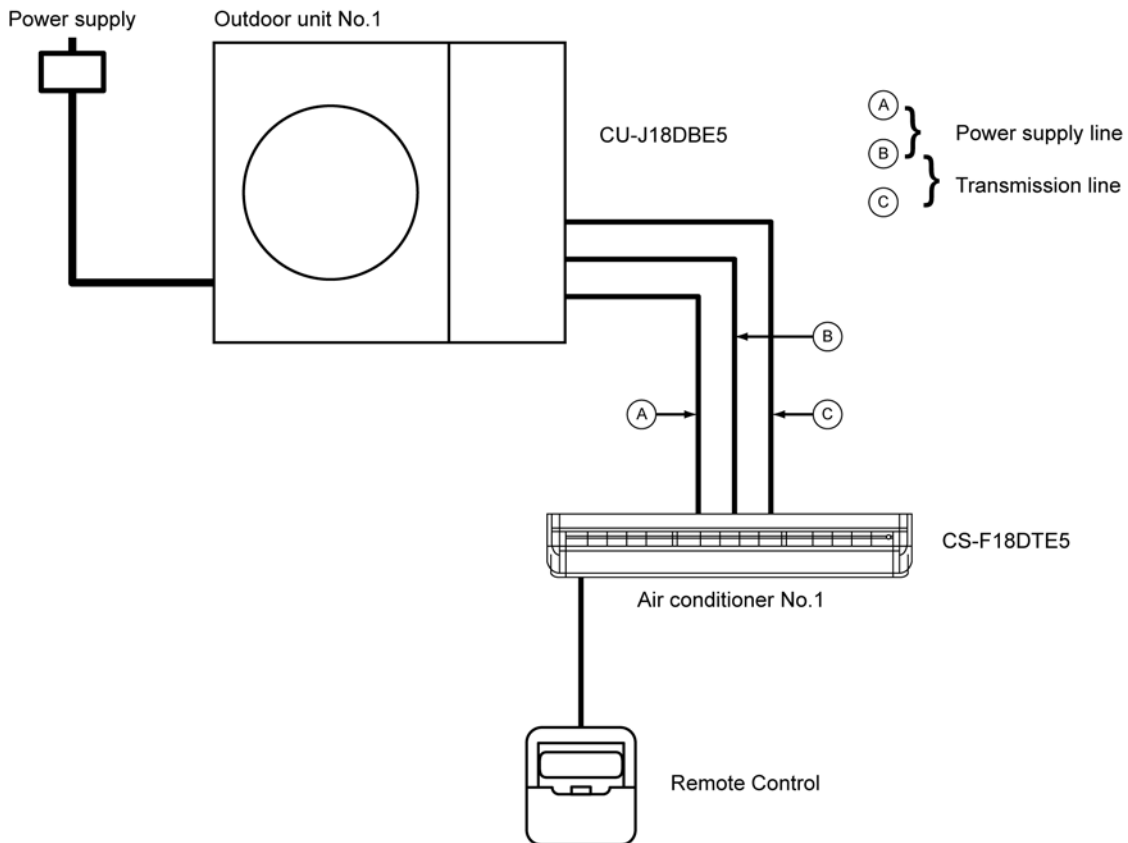

1. The main power is turned on while the indoor-outdoor transmission wires are not connected.  
(open circuit at A: power line)  
Symptom  
Indoor unit: no power supply  
Remote control unit: no power supply  
Outdoor unit: LED2, 4, 6 on P.C.B flashes
2. The main power is turned on while the indoor-outdoor transmission wires are not connected.  
(open circuit at B: power/transmission line)  
Symptom  
Indoor unit: no power supply  
Remote control unit: no power supply  
Outdoor unit: LED2, 4, 6 on P.C.B flashes
3. The main power is turned on while the indoor-outdoor transmission wires are not connected.  
(open circuit at C: transmission line)  
Symptom  
Remote control unit: "check" flashes  
Error code: F27-01 (indoor/outdoor transmission error)  
Indoor unit: LED1 on P.C.B flashes  
Outdoor unit: LED2, 4, 6 on P.C.B flashes



(When remote control display shows "power supply")  
Clock setting, and no timer setting



(When remote control display shows "No power supply")

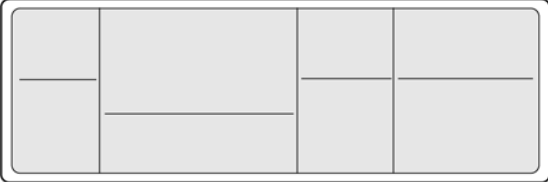

## 12.2. During group control operation

### System example

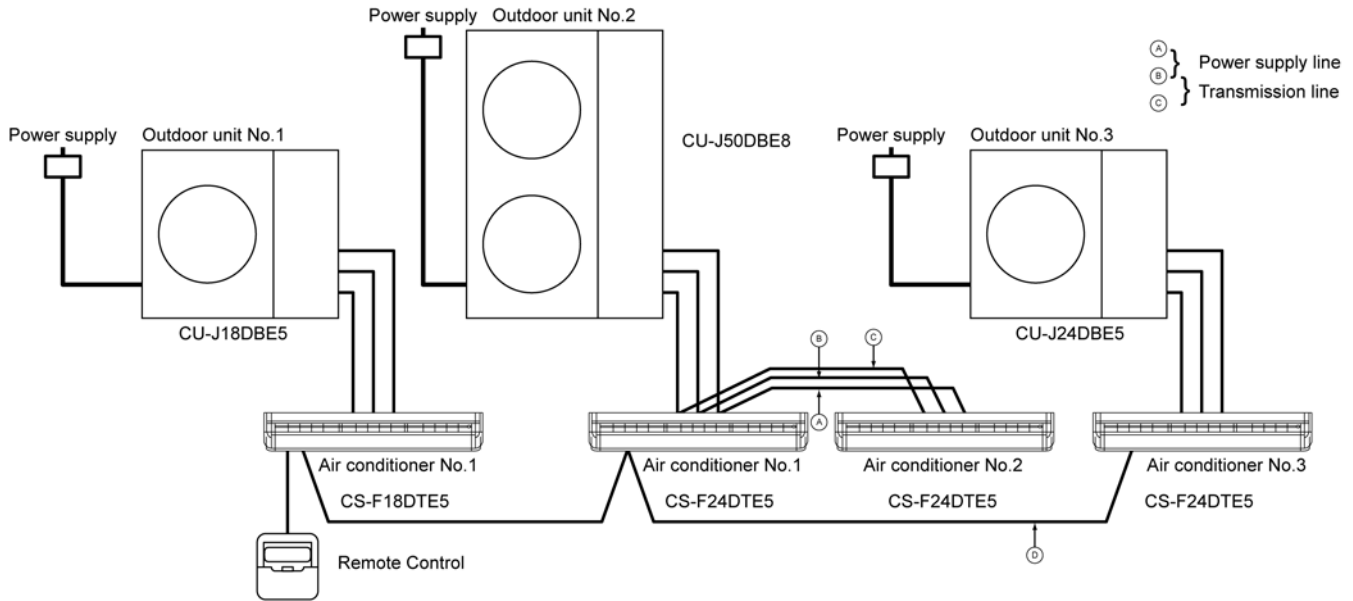

1. The main power is turned on while the transmission wires between the indoor units are not connected. (open circuit at A or B or C)

Symptom

Operation of indoor unit No.1 and No.3 is possible.

However "check" flashes in the remote control display for 3-5 minutes after main power is turned on.

Remote control unit: "check" flashes

Error code: F30-01 (indoor capacity error)

Indoor unit: LED1 on P.C.B flashes

Outdoor unit: LED6, 7 on P.C.B flashes

2. The main power is turned on while the remote control connection wire is not connected. (open circuit at section D)

Symptom

Nothing abnormal appears on the remote control display.

Operation of indoor unit No.1 and No.2 is possible.

However indoor unit No.3 cannot be operated.

### Remedy

1. Turn off the main power.  
↓
2. Connect the disconnected wire correctly.  
↓
3. Turn on the main power.  
↓
4. After 1 minute, start the operation using the remote control.  
(Indoor unit operation will start according to the remote control setting.)  
(Outdoor unit operation will start after 3-5 minutes.)

## 12.3. Test operation and self-diagnosis

### 12.3.1. Test Run (Forced Cooling mode and Heating mode)

1. Always use a properly-insulated tool to operate the switch on the circuit board.  
(Do not use your finger or any metallic object.)
2. Never turn on the power supply unit until all installation work has been completed.
3. Turn on the circuit breaker before test operation extends past 12 hours.
4. Check that the voltage is -10% of the rated voltage (198V) or higher when starting the unit.  
The unit will not operate if the voltage is less than -10% of the rated voltage (198V).
5. If test operation continue more than 30 minutes, test operation finishes and shift to normal operation.

### 12.3.2. Test operation from the outdoor unit

Press SW1 for 1 second,  
Test Run (Forced Cooling Mode)

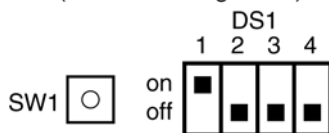

Press SW1 for 1 second,  
Test Run (Forced Heating Mode)

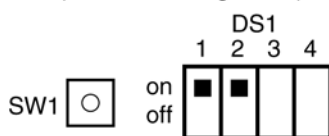

Press SW1 for 1 second,  
Pump down

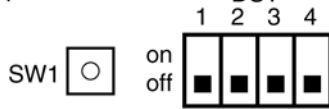

Self-diagnosis LED 2~8

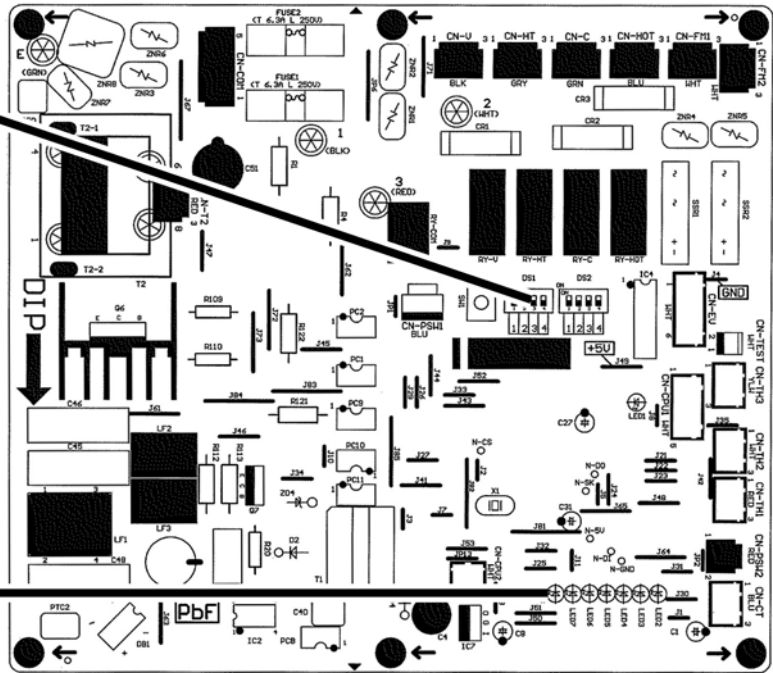

During emergency operation or when test operation is carried out, the LED on the P.C.B. will turn on.

### 12.3.3. Test operation using the wired remote control

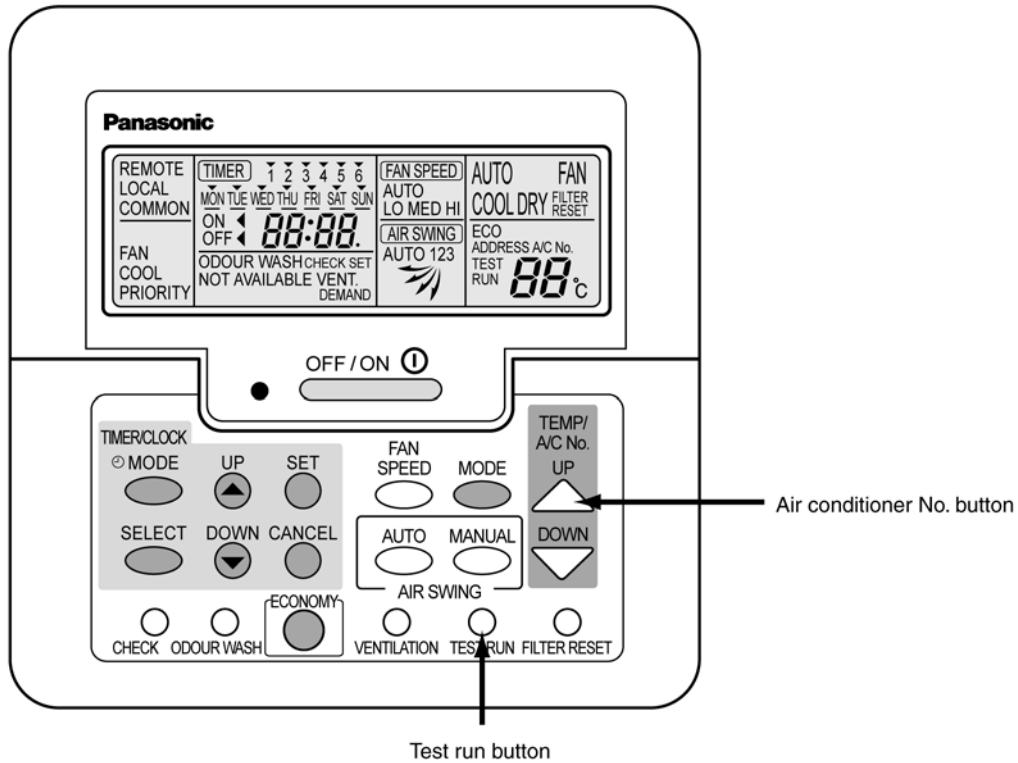

1. Check that "COOL" is displayed on the LCD, and then press the OFF/ON button to start test operation.
2. After pressing the OFF/ON button, press the TEST RUN button within 1 minute.
3. Then, the pipe temperature (gas pipe) will be displayed in the LCD of the remote control.
4. Check that the pipe temperature in the display of the remote control starts dropping after operation has been continuing for sometime.

### 12.3.4. Self-diagnosis function

The wired remote control display and the self-diagnosis LEDs (green) on the outdoor unit printed circuit board indicate where the abnormality has occurred.

Recalling the error display.

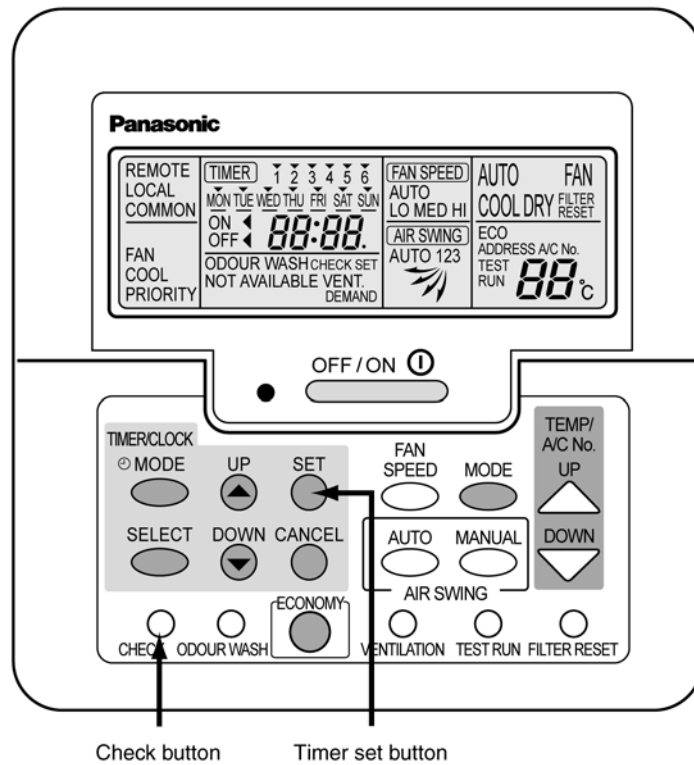

The air conditioner No."01" appears during normal installation and use.  
 When using group control, a different number may appear.  
 The air conditioner No. can be displayed by pressing the air conditioner No. button.  
 (= same as Temp. up and down button)

When an abnormality occurs at this unit, "check" flashes in the display.

- Press the check button while the display is flashing.



The timer display will change and an error code from F15 to F44 will appear in place of time.  
 (the temperature setting display will also change to show the air conditioner. No.)

- Press the timer set button while the error is displayed.

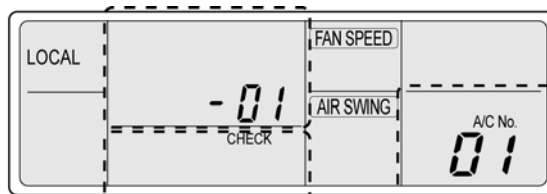

The F15-44 display will change to the detail display.

• **How to display the past error message.**

If the CHECK display on the wired remote control is not flashing, press the CHECK button continuously for 5 seconds or more to display the past problem details.

**12.3.5. Test operation using the receiver auto button  
(If using wireless remote controller)**

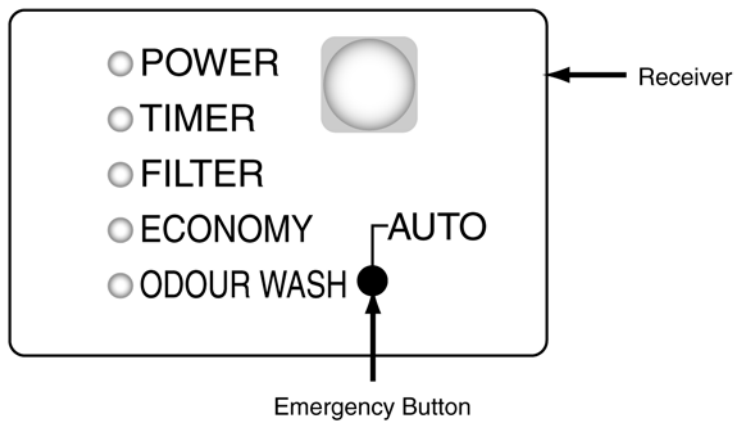

## 12.4. Emergency operation

When using the wireless remote control and losing the remote controller, emergency operation can be operated by pressing auto button in the receiver.

- Press the auto button continuously within 5 seconds

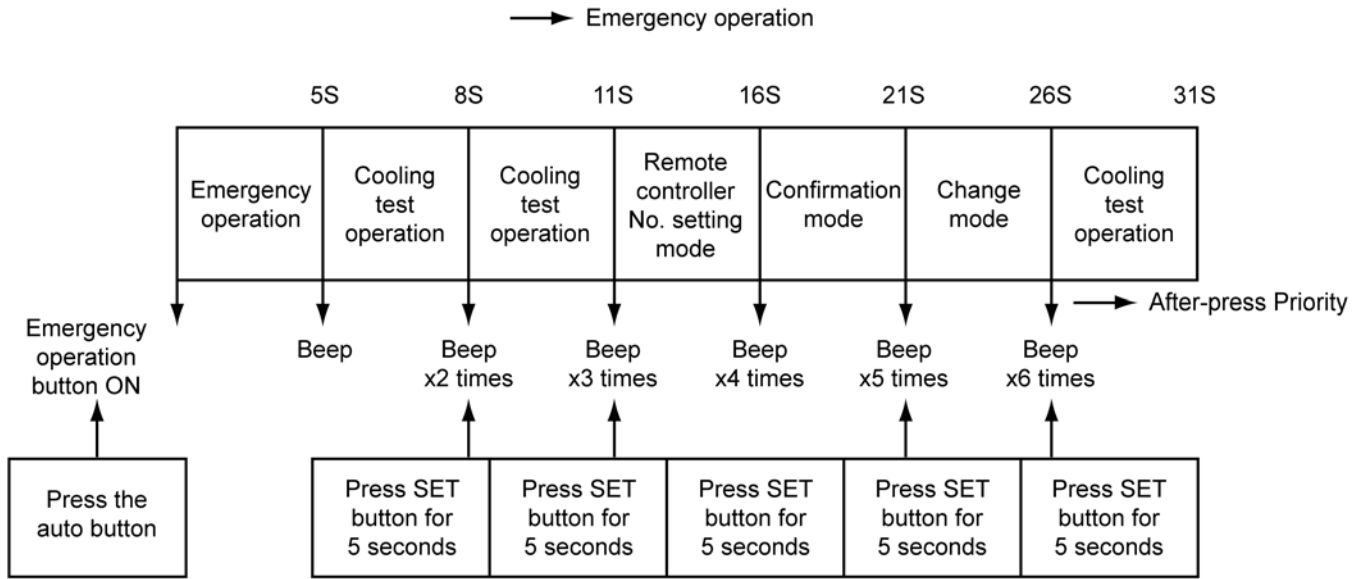

Press the auto button continuously within 5 seconds

→ emergency operation

- Press the auto button continuously for more than 5 seconds to less than 8 seconds

→ cooling test operation

- Press the auto button continuously for more than 8 seconds to less than 11 seconds

→ cooling test operation

Press the auto button continuously for more than 11 seconds to less than 16 seconds

→ set remote controller address

Press the auto button continuously for more than 16 seconds to less than 21 seconds

→ remote controller address confirmation mode

Press the auto button continuously for more than 21 seconds to less than 26 seconds

→ change address of branch unit

Press the auto button continuously for more than 26 seconds to less than 31 seconds

→ individual change mode

During the above each stage, finally press the SET button, then the operation mode can be decided.

If there is an abnormality in the temperature thermistor (disconnect or shorted), indoor unit cannot be operated.

If abnormality detected in the indoor or outdoor unit, turn off the main power supply and find the cause.

Check the resistance of each thermistor of both indoor and outdoor units by referring the resistance table as follows.

### Thermistor resistance table

Temperature °C	Resistance value (kΩ)±5%			
	Indoor		Outdoor	
	Room temperature thermistor	Pipe temperature thermistor	Discharge temperature thermistor	Pipe temperature thermistor
-20	158.5	211.3	528.3	47.9
-10	87.5	116.7	291.8	27.1
-5	66.1	88.2	220.5	20.7
0	50.5	67.3	168.3	15.9
5	38.9	51.9	129.8	12.4
10	30.3	40.4	100.9	9.8
15	23.8	31.7	79.2	7.7
20	18.8	25.1	62.7	6.2
25	15	20	50	5
30	12.1	16.1	40.2	4
40	8	10.6	26.5	2.7
50	5.4	7.2	17.9	1.9
60	3.7	5	12.4	1.3

Temperature °C	Resistance value (kΩ)±5%			
	Indoor		Outdoor	
	Room temperature thermistor	Pipe temperature thermistor	Discharge temperature thermistor	Pipe temperature thermistor
70	-	3.5	8.8	0.9
80	-	2.5	6.3	-
90	-	1.9	4.7	-
100	-	1.4	3.5	-

During outdoor unit emergency operation or test operation, the LED on the P.C.B. will flash.



## 12.5. Self-diagnosis error code table

- The display screen on the wired remote control unit and the self-diagnosis LEDs (green) on the outdoor unit printed circuit board in the outdoor unit can be used to indicate where the location of a problem is. Refer to the table below to remove the cause of the problem, and then re-start the air conditioner system.
- If the problem disappears and operation returns to normal, the CHECK display on the remote control unit will switch off, but the self-diagnosis LED will remain illuminated until operation is resumed. ○... illuminated.

LED Symbol	Description
	Off
○	Illuminated

Wired remote control unit display		Outdoor unit printed circuit board LED								Location or problem	Check location
Abnormal display	Detail display	2	3	4	5	6	7	8			
F15	-01		○	○	○	○		×	Drain level Float switch problem	Drain pump and drain pipe, indoor unit connectors	
F16	-01							○	×	Louver switch problem	Louver motor, decorative panel connection terminal, or indoor unit louver motor connectors
F17	-02	○	○					○	×	D.C. Fan motor problem	Indoor unit D.C.Fan motor or connection terminals
F20	-01				○			○	×	Indoor temperature sensor problem	Indoor temperature sensor lead wire or indoor unit connector
	-02	○			○			○	×	Remote control thermistor problem	Remote control thermistor
F21	-01		○		○			○	×	Pipe temp. sensor problem (indoor unit)	Pipe temperature sensor lead wire or indoor unit connector
F26	-01			○		○		○	×	Remote control transmission problem	Remote control unit cable and connection terminals
F27	-01		○	○		○		○	×	Indoor/outdoor unit disconnection problem	Indoor/outdoor unit connection cable and connection terminals, or indoor unit power supplies (indoor side)
	-05	○	○	○		○		○	×	Indoor/outdoor unit connection error problem	Indoor/outdoor unit connection wire (indoor side)
	-01	○		○		○				Indoor/outdoor unit disconnection problem	Indoor/outdoor unit connection cable and connection terminals, or outdoor unit power supplies (outdoor side)
	-05					○				Indoor/outdoor unit connection error problem	Indoor/outdoor unit connection wire (outdoor side)
F30	-01				○	○				System problem	Total capacity for the number of indoor units is insufficient, or over. Check the total capacity and the number of indoor units
	-02			○	○	○				Open phase, or reversed phase of supply	Check the main power supply terminal board connections, or switch over any two of the power supply wires.
F31	-01		○							Suction pressure protection	Insufficient refrigerant or valve operation (closed)
	-02	○								High-pressure cut-off	Check the Refrigeration system
	-06			○	○					4 way valve problem	Check the 4 way valve or lead wire
	-10		○	○			○			Refrigerant system problem	Valve operation (closed), or refrigerant system
F32	-05	○	○							Compressor overcurrent protection	Open phase or lock in compressor
	-06	○	○		○					Compressor discharge temp. protection	Insufficient refrigerant
F40	-21	○		○						Outdoor heat exchanger outlet temperature sensor problem	Outdoor heat exchanger outlet temperature sensor (COND TEMP) lead wire, connector
	-51		○	○						Compressor discharge temperature sensor problem	Compressor discharge temperature sensor (DIS T. TEMP) lead wire, connector
F41	-02	○	○		○	○				High pressure switch open circuit problem	High-pressure switch lead wire, connector
	-12	○		○	○	○				Low pressure sensor problem	Low pressure sensor lead wire, connector or valve operation (closed)

Wired remote control unit display		Outdoor unit printed circuit board LED								Location or problem	Check location
Abnormal display	Detail display	2	3	4	5	6	7	8			
F42	-11		○		○					Current detector open circuit Compressor internal protector worked	Outdoor unit current detector fault or connector Compressor fault or refrigeration system

(※2)

LED8	Unit No. (when twin operation)
●	Master unit problem
○	Slave unit problem

- The LED1 (green) illuminates to indicate that the microprocessor on the printed circuit board is operating normally.  
If the LED1 is switched off or blinking irregularly, check the power supply, and turn it off and then back on again.

# 13 Technical Data

## 13.1. Cooling capacity performance data

Model (CS-)	Power Source	Ambient Return Air		Temperature Air Entering Condenser (°C D.B.)																
				25°C			30°C			35°C			40°C			43°C				
		D.B.	W.B.	kW	SHC	IPT	kW	SHC	IPT	kW	SHC	IPT	kW	SHC	IPT	kW	SHC	IPT		
F18DTE5	220V, 50Hz, 1 phase	23	17	5.21	3.41	1.42	5.00	3.38	1.53	4.71	3.27	1.67	4.35	3.13	1.83	4.12	3.03	1.94		
			19	5.50	2.80	1.50	5.33	2.82	1.63	5.05	2.78	1.77	4.71	2.69	1.94	4.47	2.64	2.06		
			22	6.00	2.16	1.62	5.84	2.22	1.76	5.57	2.23	1.91	5.22	2.19	2.10	4.97	2.19	2.23		
		25	17	5.14	3.93	1.42	4.94	3.88	1.53	4.66	3.75	1.67	4.32	3.61	1.82	4.10	3.50	1.93		
			19	5.50	3.47	1.51	5.31	3.45	1.63	5.03	3.37	1.78	4.68	3.25	1.94	4.46	3.19	2.06		
			22	6.00	2.73	1.63	5.82	2.76	1.76	5.53	2.74	1.92	5.15	2.65	2.09	4.95	2.65	2.22		
		27	17	5.08	4.52	1.42	4.89	4.45	1.53	4.61	4.29	1.67	4.29	4.12	1.81	4.10	4.06	1.92		
			19	5.51	4.08	1.52	5.30	4.03	1.64	5.00	3.90	1.78	4.69	3.77	1.95	4.45	3.69	2.05		
			22	5.99	3.30	1.64	5.79	3.30	1.77	5.49	3.24	1.92	5.10	3.11	2.09	4.93	3.11	2.21		
		29	17	5.07	4.97	1.41	4.89	4.84	1.53	4.60	4.60	1.65	4.32	4.32	1.77	4.13	4.13	1.84		
			19	5.50	4.67	1.51	5.30	4.61	1.63	5.00	4.45	1.76	4.69	4.29	1.89	4.47	4.21	1.97		
			22	5.97	3.91	1.66	5.77	3.89	1.80	5.45	3.79	1.94	5.11	3.68	2.08	4.89	3.62	2.17		
		32	17	5.06	4.96	1.41	4.89	4.89	1.53	4.28	4.28	1.63	4.34	4.34	1.74	4.14	4.14	1.79		
			19	5.49	5.44	1.50	5.30	5.30	1.63	5.00	5.00	1.74	4.71	4.71	1.86	4.49	4.49	1.91		
			22	5.96	4.88	1.68	5.75	4.83	1.80	5.40	4.69	1.95	5.11	4.55	2.07	4.87	4.43	2.14		
		F18DTE5	230V, 50Hz, 1 phase	23	17	5.21	3.41	1.44	5.00	3.38	1.56	4.71	3.27	1.70	4.35	3.13	1.86	4.12	3.03	1.98
					19	5.50	2.80	1.53	5.33	2.82	1.65	5.05	2.78	1.80	4.71	2.69	1.98	4.47	2.64	2.10
					22	6.00	2.16	1.65	5.84	2.22	1.79	5.57	2.23	1.95	5.22	2.19	2.13	4.97	2.19	2.26
25	17			5.14	3.93	1.44	4.94	3.88	1.56	4.66	3.75	1.70	4.32	3.61	1.85	4.10	3.50	1.96		
	19			5.50	3.47	1.54	5.31	3.45	1.66	5.03	3.37	1.81	4.68	3.25	1.97	4.46	3.19	2.09		
	22			6.00	2.73	1.66	5.82	2.76	1.79	5.53	2.74	1.95	5.15	2.65	2.13	4.95	2.65	2.26		
27	17			5.08	4.52	1.44	4.89	4.45	1.56	4.61	4.29	1.69	4.29	4.12	1.84	4.10	4.06	1.95		
	19			5.51	4.08	1.54	5.30	4.03	1.66	5.00	3.90	1.81	4.69	3.77	1.98	4.45	3.69	2.09		
	22			5.99	3.30	1.67	5.79	3.30	1.80	5.49	3.24	1.95	5.10	3.11	2.12	4.93	3.11	2.25		
29	17			5.07	4.97	1.44	4.89	4.84	1.55	4.60	4.60	1.67	4.32	4.32	1.80	4.13	4.13	1.89		
	19			5.50	4.67	1.53	5.30	4.61	1.66	5.00	4.45	1.79	4.69	4.29	1.92	4.47	4.21	2.02		
	22			5.97	3.91	1.69	5.77	3.89	1.83	5.45	3.79	1.97	5.11	3.68	2.12	4.89	3.62	2.23		
32	17			5.06	4.96	1.43	4.89	4.89	1.55	4.28	4.28	1.66	4.34	4.34	1.77	4.14	4.14	1.85		
	19			5.49	5.44	1.53	5.30	5.30	1.66	5.00	5.00	1.77	4.71	4.71	1.89	4.49	4.49	1.98		
	22			5.96	4.88	1.71	5.75	4.83	1.80	5.42	4.69	1.98	5.11	4.55	2.11	4.87	4.43	2.21		
F18DTE5	240V, 50Hz, 1 phase			23	17	5.21	3.41	1.46	5.00	3.38	1.59	4.71	3.27	1.73	4.35	3.13	1.90	4.12	3.03	2.01
					19	5.50	2.80	1.55	5.33	2.82	1.68	5.05	2.78	1.83	4.71	2.69	2.01	4.47	2.64	2.13
					22	6.00	2.16	1.68	5.84	2.22	1.82	5.57	2.23	1.98	5.22	2.19	2.17	4.97	2.19	2.30
		25	17	5.14	3.93	1.47	4.94	3.88	1.58	4.66	3.75	1.72	4.32	3.61	1.88	4.10	3.50	2.00		
			19	5.50	3.47	1.56	5.31	3.45	1.69	5.03	3.37	1.84	4.68	3.25	2.00	4.46	3.19	2.12		
			22	6.00	2.73	1.69	5.82	2.76	1.82	5.53	2.74	1.98	5.15	2.65	2.16	4.95	2.65	2.29		
		27	17	5.08	4.52	1.47	4.89	4.45	1.58	4.61	4.29	1.72	4.29	4.12	1.87	4.10	4.06	1.98		
			19	5.51	4.08	1.57	5.30	4.03	1.69	5.00	3.90	1.84	4.70	3.77	2.02	4.45	3.69	2.12		
			22	5.99	3.30	1.70	5.79	3.30	1.83	5.49	3.24	1.99	5.10	3.11	2.16	4.93	3.11	2.29		
		29	17	5.07	4.97	1.46	4.89	4.84	1.58	4.60	4.60	1.70	4.32	4.32	1.83	4.13	4.13	1.92		
			19	5.50	4.67	1.56	5.30	4.61	1.69	5.00	4.45	1.82	4.69	4.29	1.95	4.47	4.21	2.05		
			22	5.97	3.91	1.72	5.77	3.89	1.86	5.45	3.79	2.00	5.11	3.68	2.15	4.89	3.62	2.26		
		32	17	5.06	4.96	1.45	4.89	4.89	1.58	4.28	4.28	1.69	4.34	4.34	1.80	4.14	4.14	1.88		
			19	5.49	5.44	1.55	5.30	5.30	1.68	5.00	5.00	1.80	4.71	4.71	1.92	4.49	4.49	2.01		
			22	5.96	4.88	1.73	5.75	4.83	1.86	5.42	4.69	2.01	5.11	4.65	2.14	4.87	4.43	2.24		

TC: Cooling Capacity  
 SHC: Sensible Heat Capacity  
 IPT: Cooling Power Consumption

## 13.2. Capacity and power consumption

### 13.2.1. Cooling Performance

Model	Cooling capacities are based on conditions
CS-F18DTE5	Single phase, 50Hz 220V
Cooling capacity	Indoor temp. 27°C D.B. 19°C W.B.
5.0kW	Outdoor temp. 35°C D.B.
	Standard air volume 14 m <sup>3</sup> /min

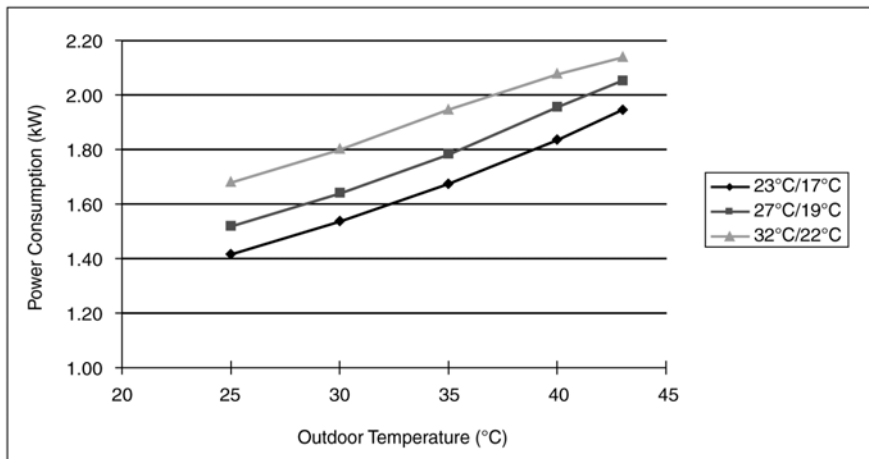
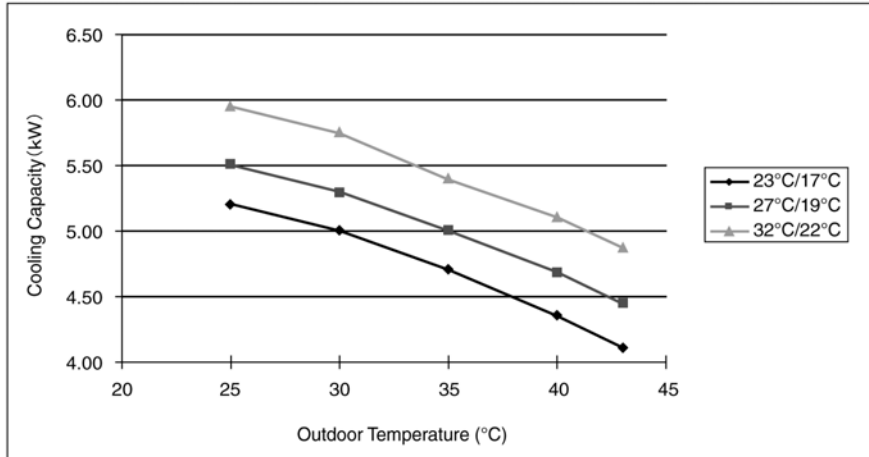

Model	Cooling capacities are based on conditions
CS-F18DTE5	Single phase, 50Hz 230V
Cooling capacity	Indoor temp. 27°C D.B. 19°C W.B.
5.0kW	Outdoor temp. 35°C D.B.
	Standard air volume 14 m <sup>3</sup> /min

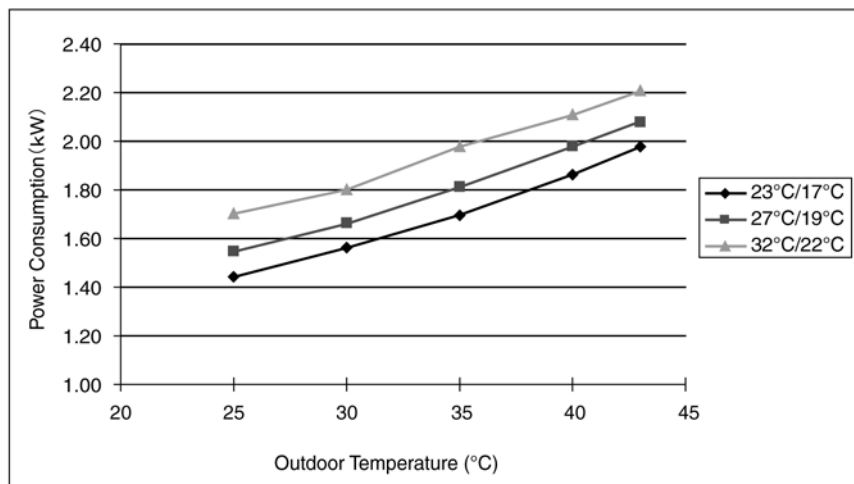
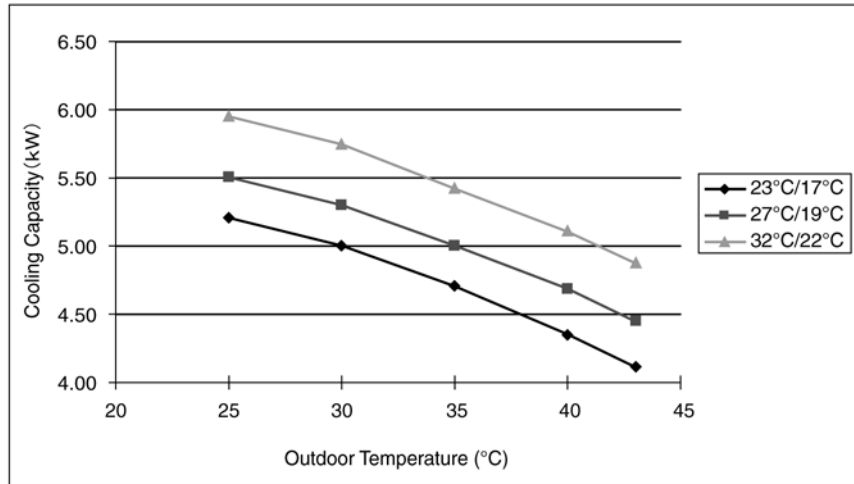

Model	Cooling capacities are based on conditions
CS-F18DTE5	Single phase, 50Hz 240V
Cooling capacity	Indoor temp. 27°C D.B. 19°C W.B.
5.0kW	Outdoor temp. 35°C D.B.
	Standard air volume 14 m <sup>3</sup> /min

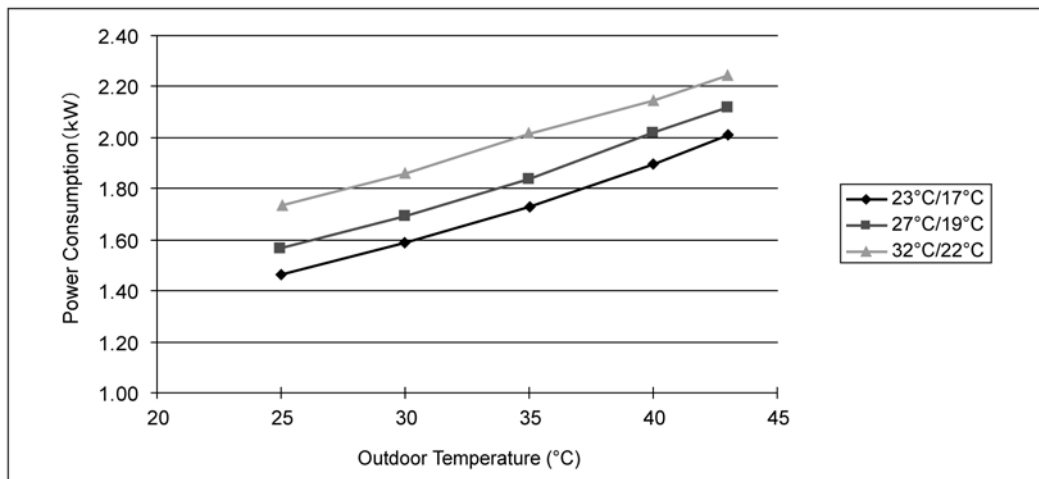
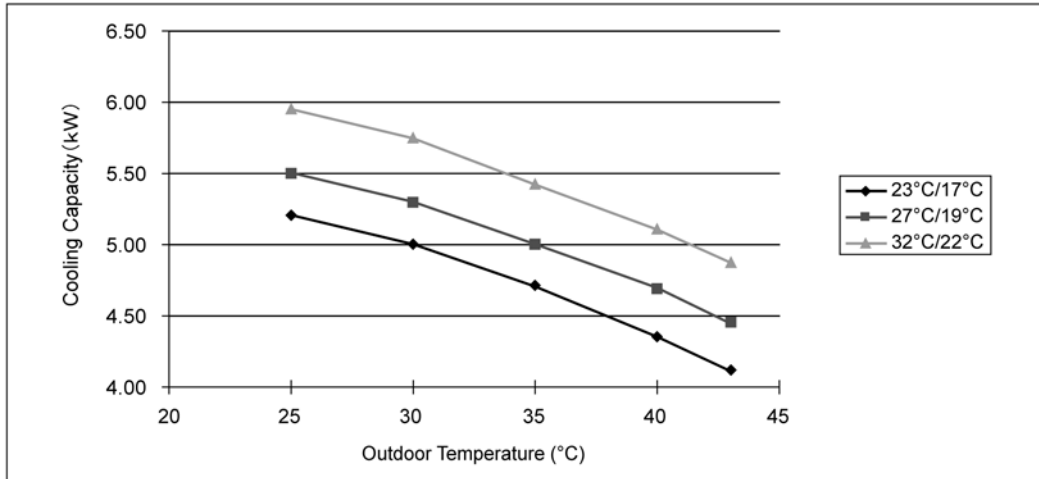

### 13.3. Reaching distance

• CS-F18DTE5

<Cooling>

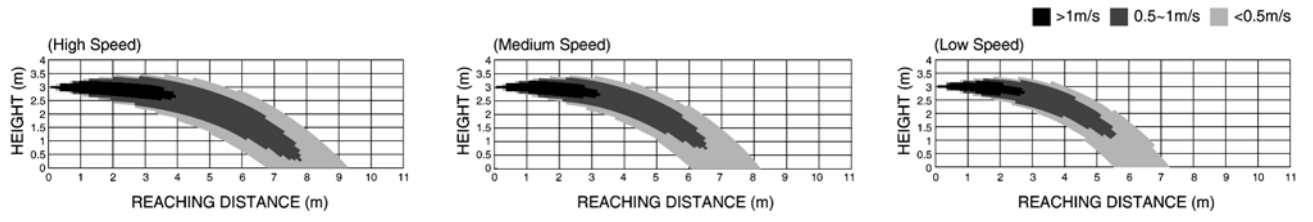

# 13.4. Sound data

CS-F18DTE5

Octave Band Central Frequency(Hz)

H ○—○  
M △—△  
L □—□

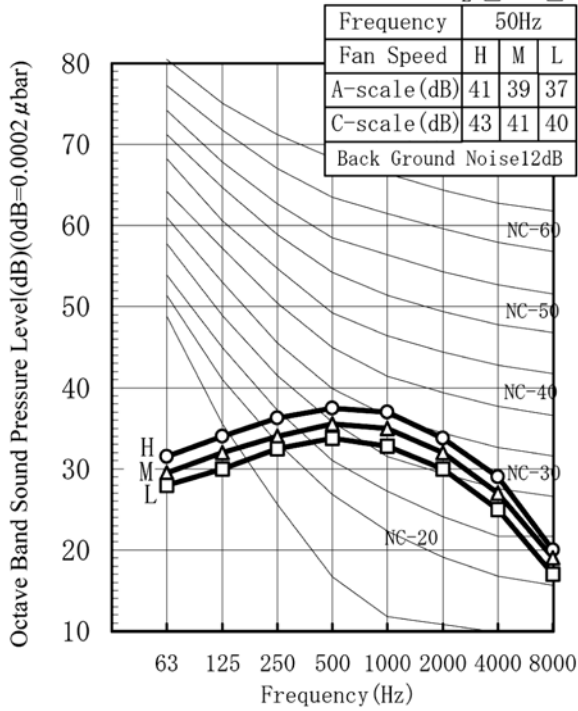

CU-J18DBE5 (Cooling)

Octave Band Central Frequency(Hz)

H ○—○

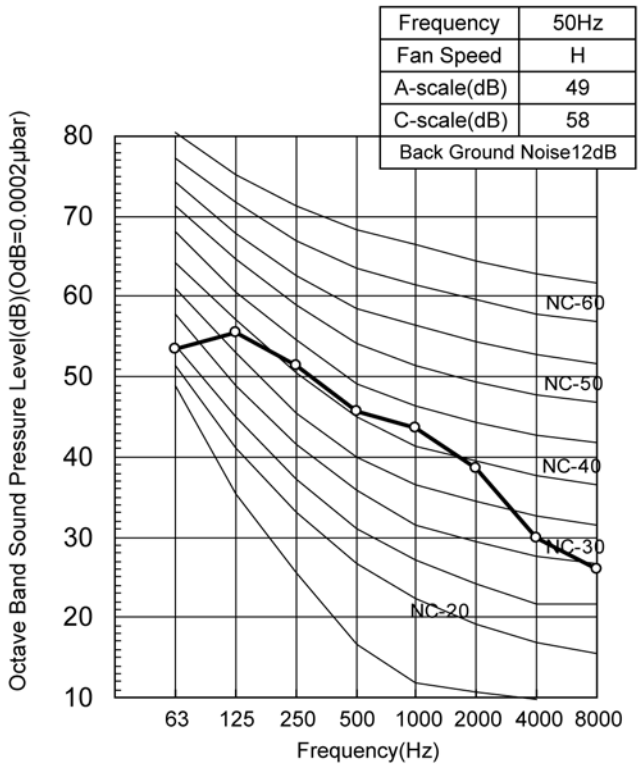



## 13.5. Sound measuring point

### 13.5.1. Indoor Unit

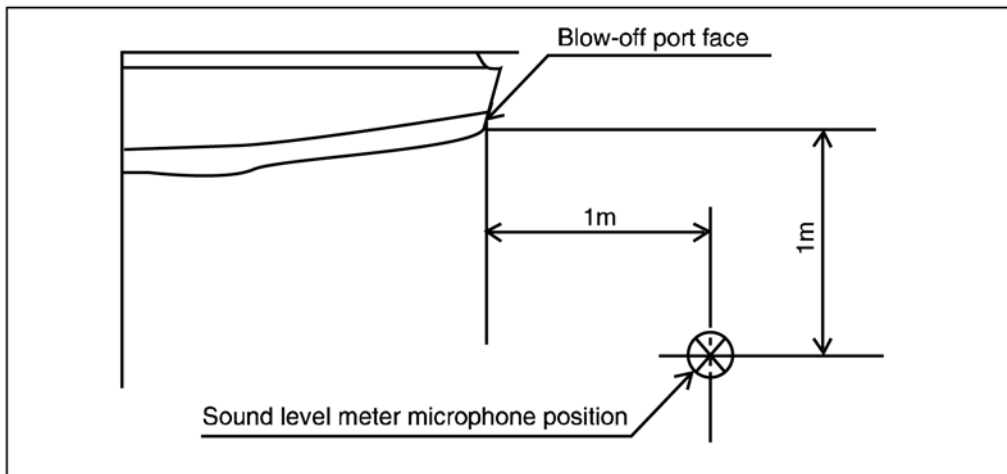
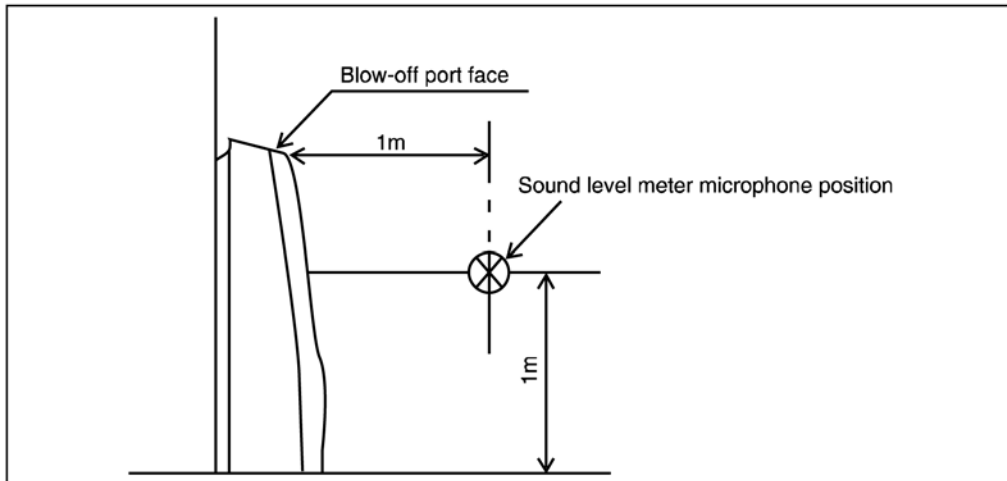

### 13.5.2. Outdoor Unit

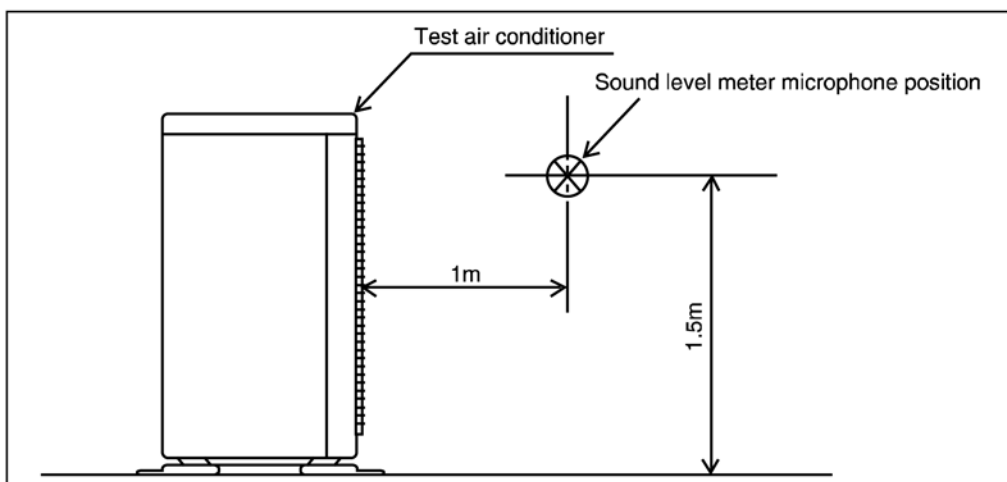

## 13.6. Fan performance

CS-F18DTE5 (220/230/240V)

ITEM/MODEL		Indoor Unit			Outdoor Unit
		CS-F18DTE5			CU-J18DBE5
MODE		Hi	Me	Lo	Hi
Air Volume	m <sup>3</sup> /min	16	14	12	57
Running Current	A	0.35	0.28	0.28	0.57/0.58/0.59
Power Consumption	kW	0.07	0.06	5	0.124/0.130/0.135
Fan Speed	r/min	1100	950	880	656/676/696

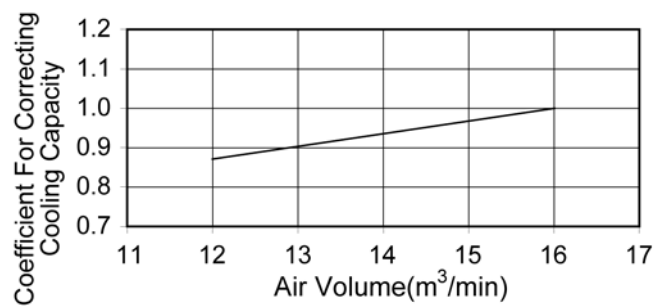

# 13.7. Discharge and suction pressure

## SATURATION TEMPERATURE OF DISCHARGE AND SUCTION PRESSURE

### COOLING

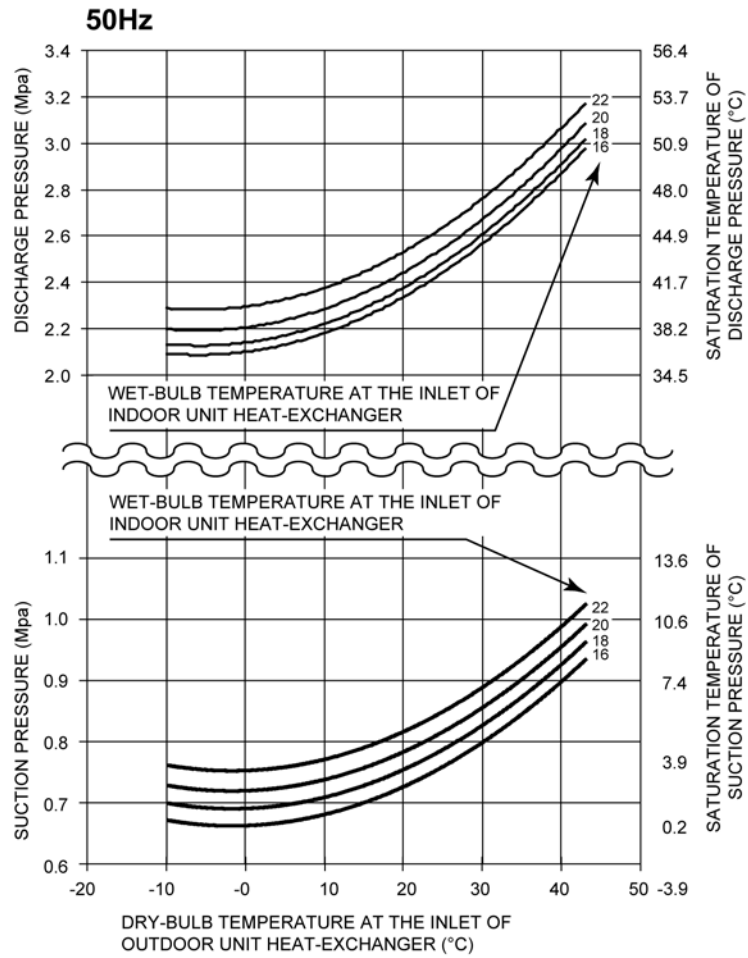

# 13.8. Operating characteristics

## COOLING ONLY MODEL

Model	Main Power Source		Compressor Motor			Indoor Unit Fan Motor		Outdoor Unit Fan Motor		Electrical Data (50Hz)	
	Voltage	Frequency	S.C.	R.C. (A)	IPT (kW)	R.C.	IPT	R.C.	IPT	Current. (A)	Power Consumption (kW)
	(V)	(Hz)	(A)	COOL	COOL	(A)	(kW)	(A)	(kW)	COOL	COOL
CS-F18DTE5	220	50	26	7.30	1.59	0.28	0.06	0.57	0.12	8.15	1.78
CU-J18DBE5	230	50	27	7.23	1.62	0.29	0.07	0.58	0.13	8.10	1.81
	240	50	28	7.17	1.64	0.29	0.07	0.59	0.14	8.05	1.84

Legend : S.C. : Starting Current  
 R.C. : Running Current  
 IPT : Power Consumption

# 14 Exploded View (Indoor Unit)

## 14.1. CS-F18DTE5

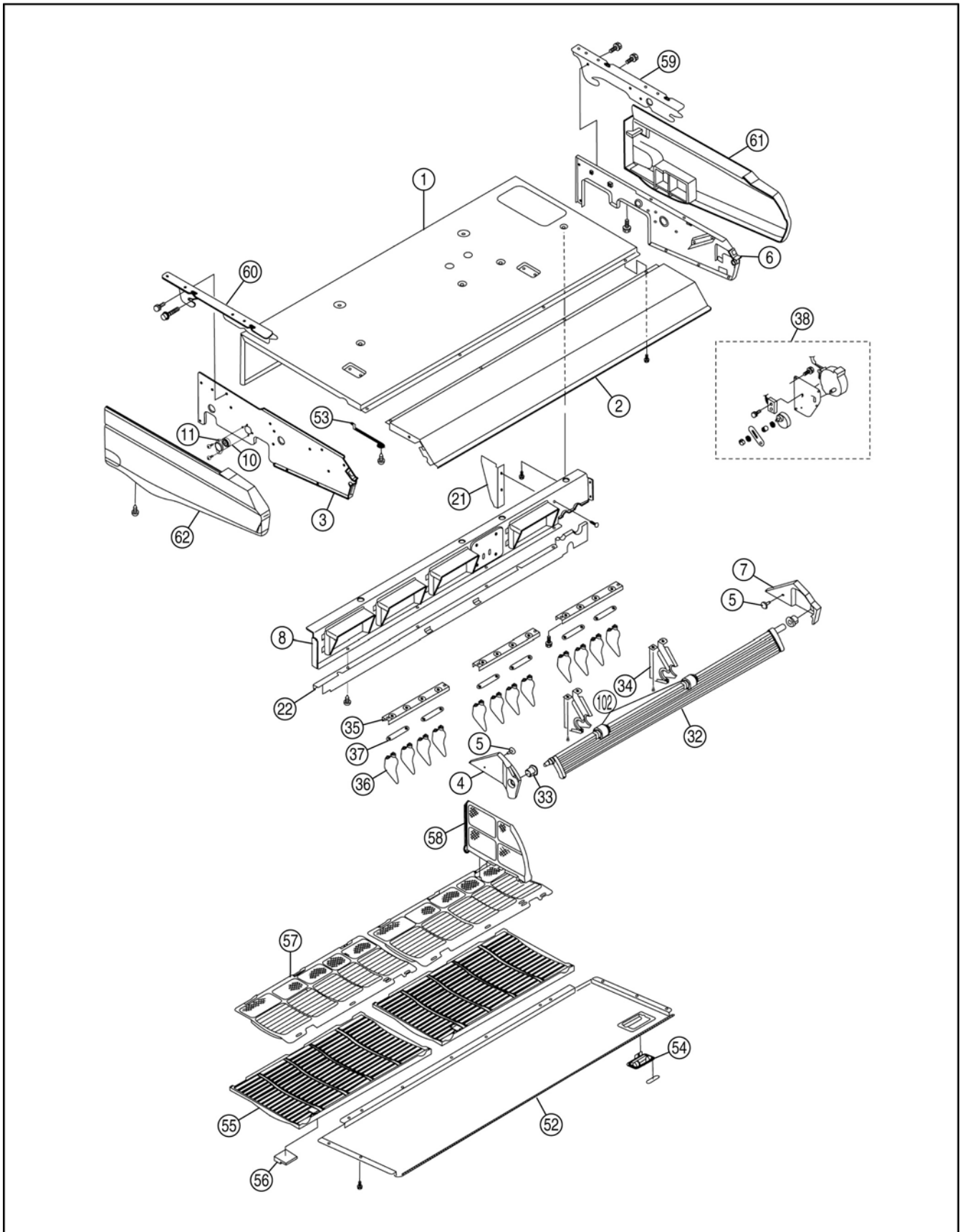

## 14.2. CS-F18DTE5

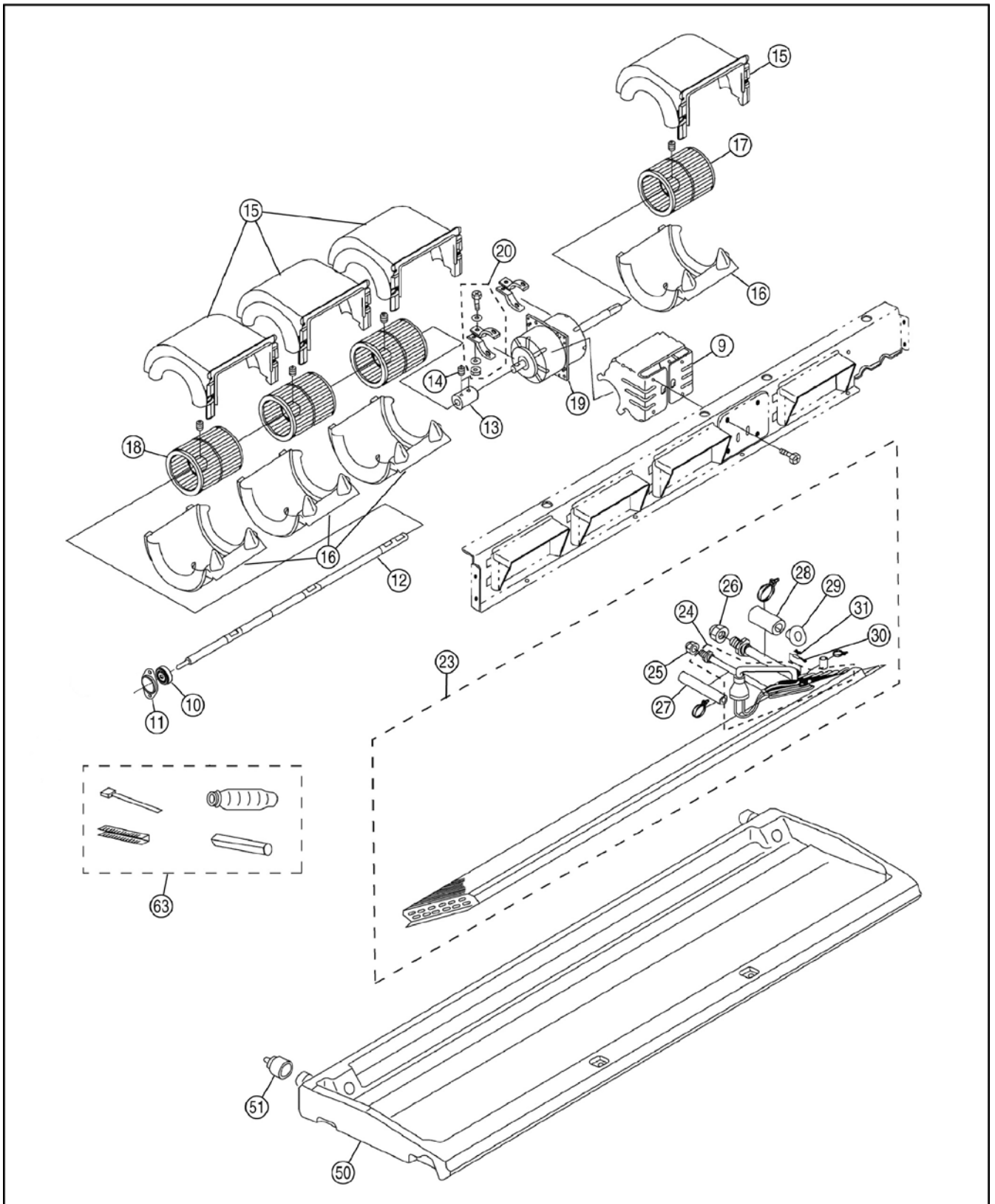

### 14.3. CS-F18DTE5

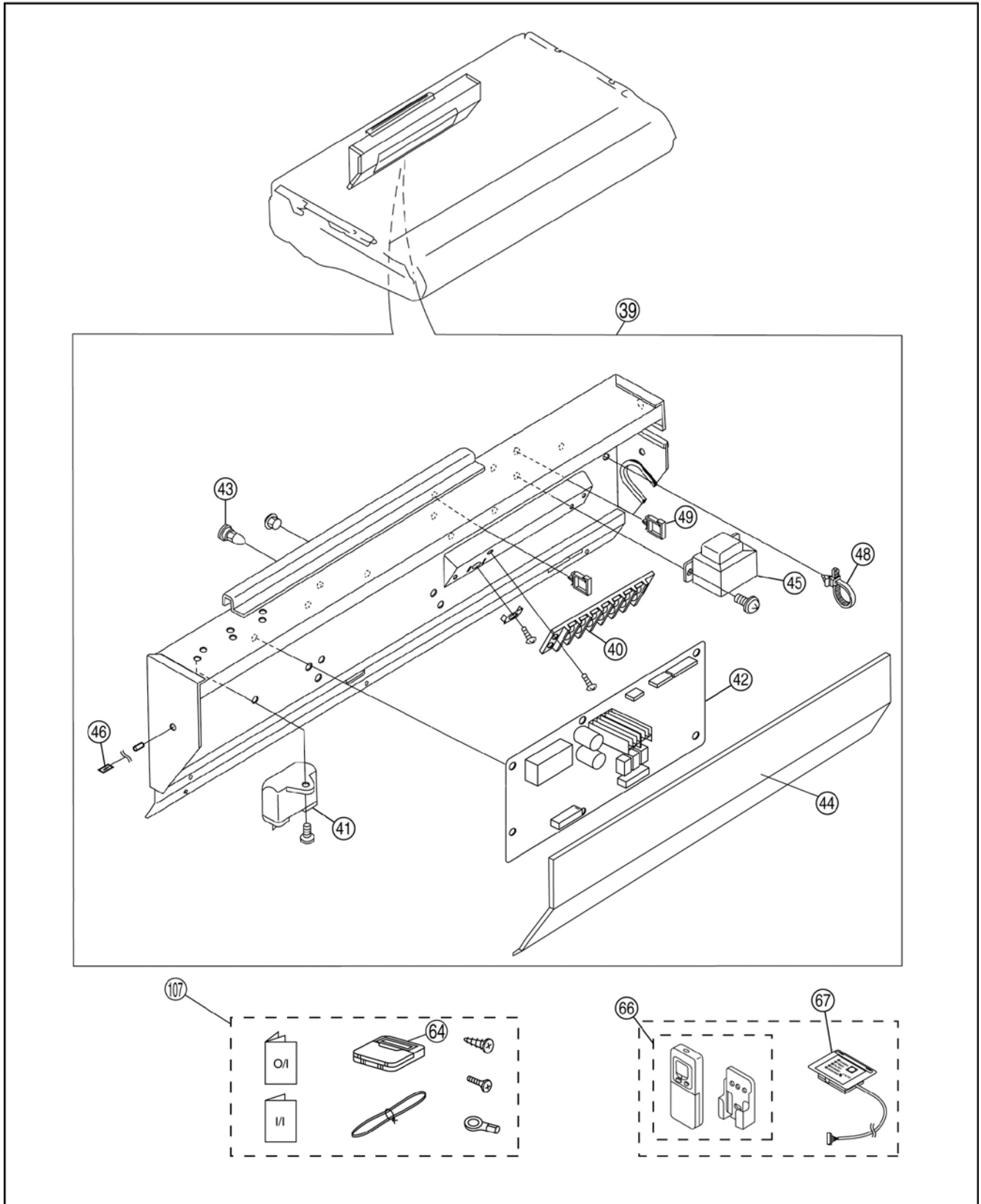

# 15 Replacement Part List (Indoor Unit)

## 15.1. CS-F18DTE5

NO.	PART DESCRIPTION	QTY.	CS-F18DTE5
1	CABINET TOP PLATE	1	CWE001015
2	CABINET FRONT PLATE	1	CWG07K1009
3	CABINET SIDE PLATE (L)	1	CWD63K1001
4	VANE SUPPORTER (L)	1	CWG071146
5	CATCHER	1	CWH601005
6	CABINET SIDE PLATE (R)	1	CWD63K1002
7	VANE SUPPORTER (R)	1	CWG071147
8	BLOWER WHEEL BASE ASS'Y	1	CWD90K1007
9	BRACKET FAN MOTOR ASS'Y	1	CWD54K1006
10	BEARING	1	CWH64C1001
11	BEARING COVER	1	CWD911196
12	FAN SHAFT	1	CWH631030
13	COUPLING SHAFT COMPLETE	1	CWH08C1001
14	SCREW-COUPLING SHAFT COMPLETE	2	CWH55424
15	AIR GUIDER B. WHEEL (TOP)	4	CWD321026
16	AIR GUIDER B. WHEEL (BOTTOM)	4	CWD321027
17	BLOWER WHEEL	1	CWH011004
18	BLOWER WHEEL	3	CWH011009
19	FAN MOTOR	1	CWA921052
20	FAN MOTOR SUPPORTER	2	CWD93C1027
21	SIDE FILTER SEAL	1	CWD911158
22	SEPARATOR	1	CWD911106
23	EVAPORATOR COMPLETE	1	CWB30C1750
24	TUBE ASS'Y (CAPIL. TUBE-EVA)	1	CWT07K1246
25	FLARE NUT (1/4")	1	CWT251032
26	FLARE NUT (1/2")	1	CWT251026
27	HEATPROOF TUBE [LIQUID]	1	CWG021024
28	HEATPROOF TUBE [GAS]	1	CWG021022
29	WATERPROOF COVER	1	CWG251006
30	SENSOR-EVAPORATOR	1	CWA50C2232
31	HOLDER SENSOR	1	CWH32137
32	VANE COMPLETE	1	CWE24C1016
33	VANE SIDE HOLDER	2	CWH511027
34	FULCRUM	2	CWH621008A
35	VERTICAL VANE HOLDER (MANUAL)	3	CWD911107
36	VERTICAL VANE (HORIZ.AIR FLOW)	12	CWE241051
37	CONNECTING BAR	6	CWE261019
38	AIR SWING MOTOR COMPLETE	1	CWA98C1004
39	CONTROL BOARD ASS'Y	1	CWH10K1050
40	TERMINAL BOARD	1	CWA281031
41	CAPACITOR-FAN MOTOR (MF/V)	1	DS451125BPQB
42	ELECTRONIC CONTROLLER-MAIN	1	CWA73C1694
43	LOCKING GUARD SPACER	6	CWH541026
44	CONTROL BOARD COVER-COMPLETE	1	CWH13C1106
45	TRANSFORMER	1	CWA40C1031
46	SENSOR COMPLETE	1	CWA50C2233
48	CABLE CLIP (CORD CLAMPER)	1	CWH88133
49	WIRE SADDLE	4	CWH881016
50	DRAIN PAN ASS'Y	1	CWH40K1014
51	DRAIN PLUG	1	CWB821002
52	CABINET BOTTOM PLATE	1	CWE051001A
53	CURVED WIRE	1	CWH751002
54	RAY RECEIVER HOLDER	1	CWD911428
55	INTAKE GRILLE (LARGE)	2	CWE221029
56	GRILLE SLIDE HOOK	4	CWH891001
57	AIR FILTER (MAIN)	2	CWD001169
58	AIR FILTER (SIDE)	1	CWD001041
59	BRACKET HANGER (R)	1	CWD601014
60	BRACKET HANGER (L)	1	CWD601015
61	CABINET SIDE COVER (R)	1	CWE041022
62	CABINET SIDE COVER (L)	1	CWE041023

NO.	PART DESCRIPTION	QTY.	CS-F18DTE5
63	FLEXIBLE PIPE-ACCESSORY	1	CWH82C1297
64	WIRED REMOTE CONTROL COMPLETE	1	CWA75C2586
66	WIRELESS REMOTE CONTROL COMP.	1	CWA75C2588
67	RAY RECEIVER	1	CWD76C1030
102	BEARING	2	CWH641004
107	WIRED REMOTE CONTROL CO. (ACCESSORY)	1	CWG50C2604
	OPERATING INSTRUCTION	1	CWF564868
	OPERATING INSTRUCTION	1	CWF564869
	OPERATING INSTRUCTION	1	CWF564870
	OPERATING INSTRUCTION	1	CWF564871
	OPERATING INSTRUCTION	1	CWF564882
	INSTALLATION INSTRUCTION	1	CWF612642
	INSTALLATION INSTRUCTION	1	CWF612836

All parts are supplied from PHAAM, Malaysia (Vendor Code: 061)



# 16 Exploded View (Outdoor Unit)

## 16.1. CU-J18DBE5

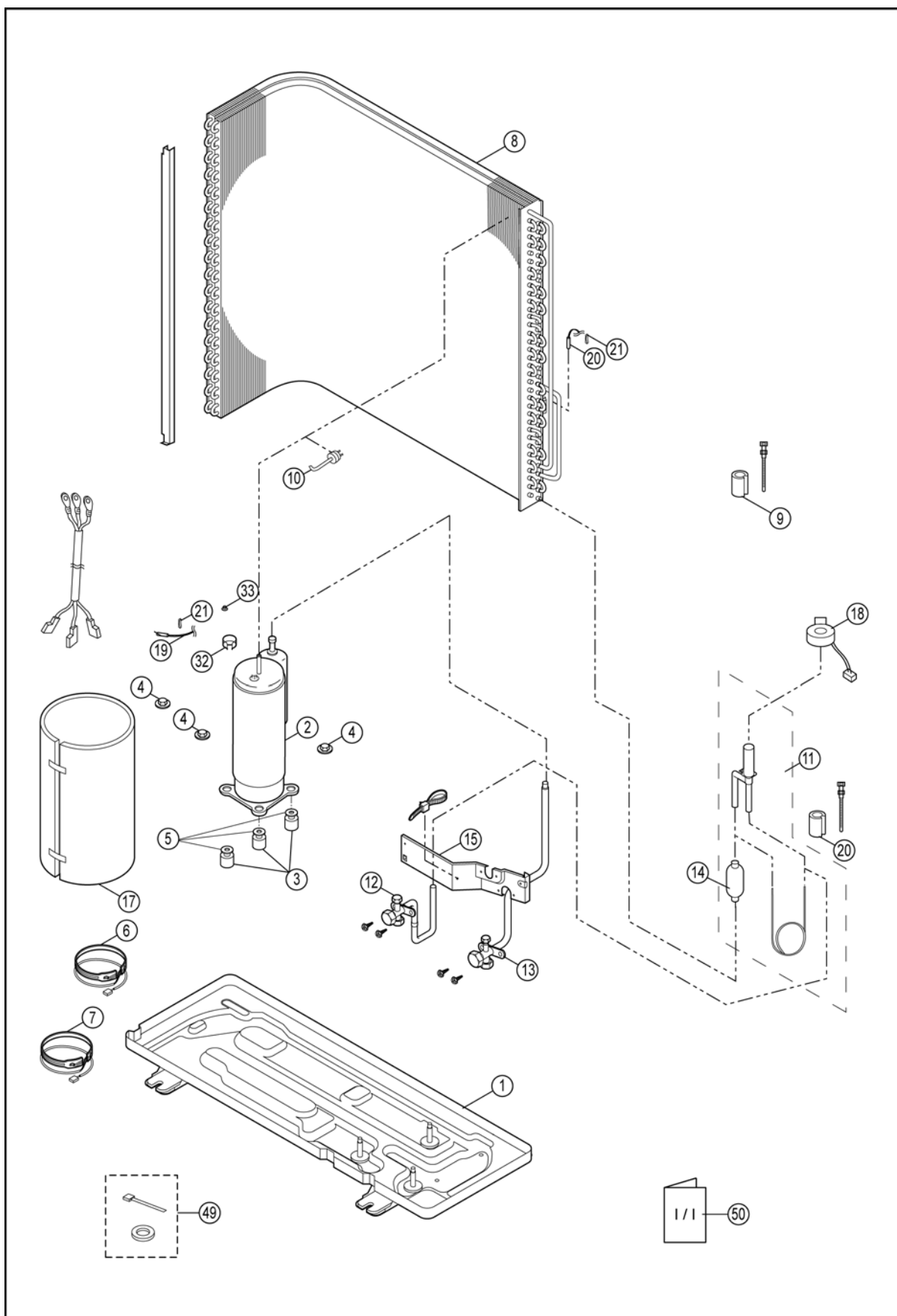

## 16.2. CU-J18DBE5

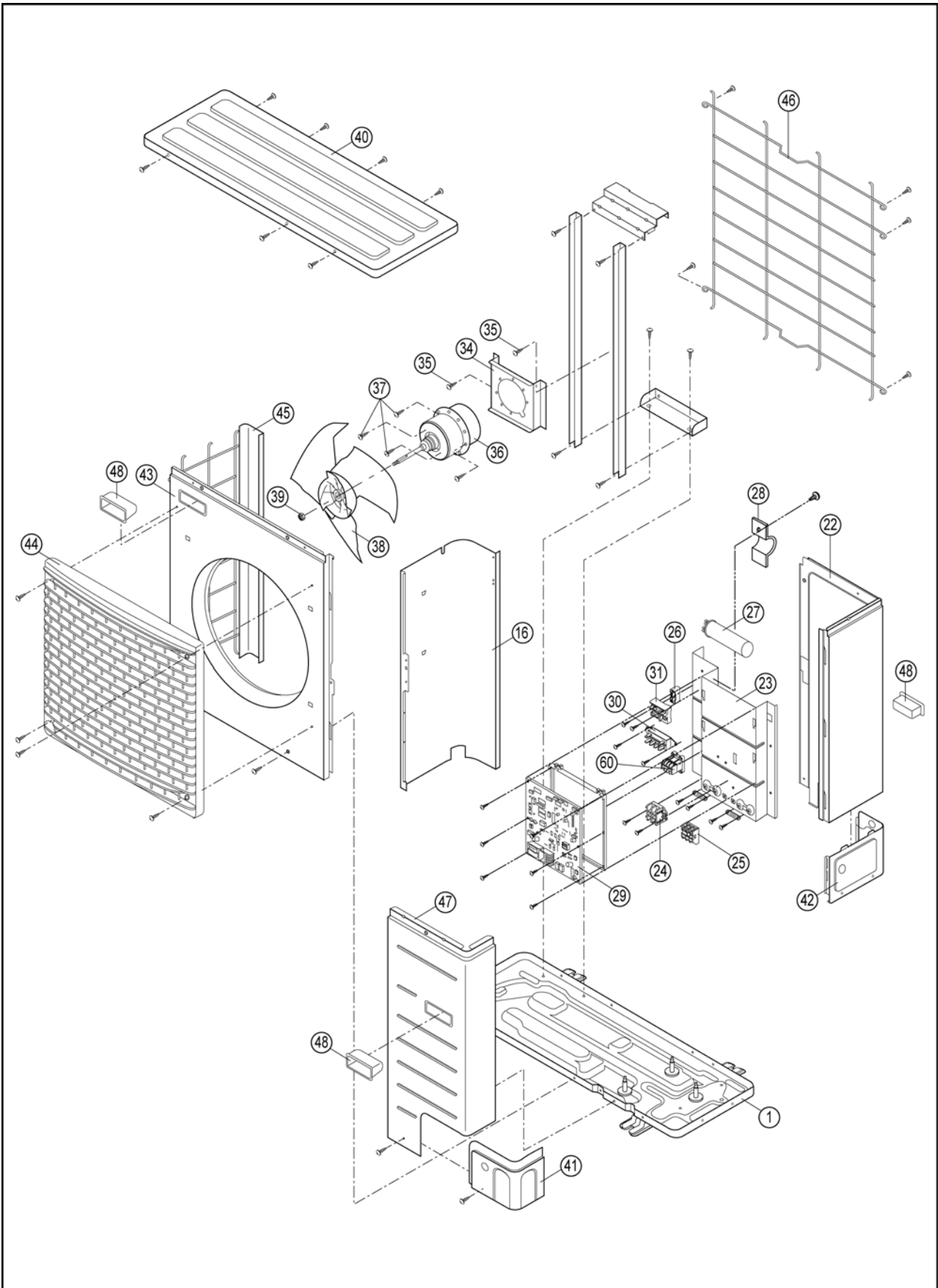

# 17 Replacement Part List (Outdoor Unit)

## 17.1. CU-J18DBE5

NO.	PART DESCRIPTION	QTY.	CU-J18DBE5
1	BASE PAN ASS'Y	1	CWD52K1159
2	COMPRESSOR	1	5KS205DAH21
3	ANTI-VIBRATION BUSHING	3	CWH50055
4	NUT COMPRESSOR MOUNT	3	CWH561049
5	GASKET FOR TERMINAL COVER	3	CWB811017
6	CRANKCASE HEATER	1	CWA341033
7	CRANKCASE HEATER	1	CWA341035
8	CONDENSER COMPLETE	1	CWB32C1810
9	PIPE HOLDER RUBBER	1	CWG251022
10	HEATING PRESSURE SWITCH	1	CWA101007
11	TUBE ASS'Y(EXP.VALVE AND STRAINER)	1	CWT024345
12	3-WAYS VALVE(LIQUID)	1	CWB011423
13	3-WAYS VALVE(GAS)	1	CWB011425
14	STRAINER	2	CWB111032
15	HOLDER-SERVICE VALVE	1	CWD911425
16	SOUND PROOF BOARD	1	CWH151078
17	SOUND PROOF MATERIAL	1	CWG302338
18	V-COIL COMPLETE	1	CWA43C2128J
19	PIPING SENSOR	1	CWA50C2292
20	PIPING SENSOR	1	CWA50C2293
21	SPRING FOR SENSOR	2	CWH711010
22	CABINET REAR PLATE COMPLETE	1	CWE02C1035
23	CONTROL BOARD ASS'Y	1	CWH10K1063
24	TERMINAL BOARD ASS'Y	1	CWA28K1085J
25	TERMINAL BOARD ASS'Y	1	CWA28K1076J
26	CAPACITOR-FM (2.0μF/460V) (2.5μF/460V)	1	DS461255QP-A
27	CAPACITOR-COMP. (30μF/370V) (50μF/370V)	1	DS371506CPNA
28	HOLDER CAPACITOR	1	CWH30060
29	ELECTRONIC CONTROLLER (MAIN)	1	CWA73C1891
30	MAGNETIC RELAY	1	K6C4E8A00003
31	TRANSFORMER	1	CWA401060
32	TERMINAL COVER	1	CWH171012
33	NUT FOR TERMINAL COVER	1	CWH7080300J
34	BRACKET FAN MOTOR ASS'Y	1	CWD54K1025
35	SCREW-FAN MOTOR BRACKET	2	CWH551040J
36	FAN MOTOR AC 70W SINGLE	1	CWA951366J
37	SCREW-FAN MOTOR	4	CWH551040J
38	PROPELLER FAN	1	CWH001019
39	NUT-PROPELLER FAN	1	CWH561038J
40	CABINET TOP PLATE COMPLETE	1	CWE03C1039
41	PIPE COVER (FRONT)	1	CWD601074A
42	PIPE COVER (BACK)	1	CWD60K1003A
43	CABINET FRONT PLATE	1	CWE061118A
44	DISCHARGE GRILLE	1	CWE201073
45	CABINET SIDE PLATE ASSY	1	CWE04K1019A
46	WIRE NET	1	CWD041063A
47	CABINET FRONT PLATE COMPLETE	1	CWE06C1131
48	HANDLE	3	CWE161008
49	WIRING COVER AND BAND	1	CWH82C1105
50	INSTALLATION INSTRUCTION	1	CWF613006

All parts are supplied from PHAAM, Malaysia (Vendor Code: 061)

# 18 Print Pattern

## 18.1. Indoor Unit Printed (Main)

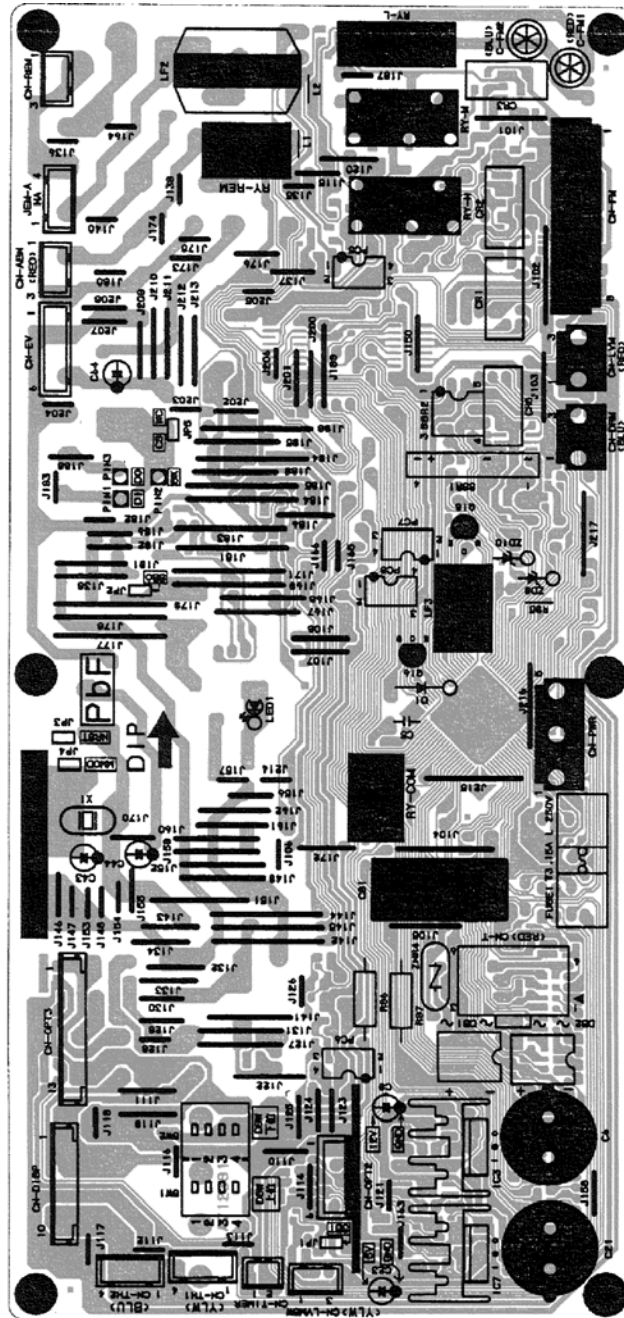

## 18.2. Indoor Unit Printed (Indicator)

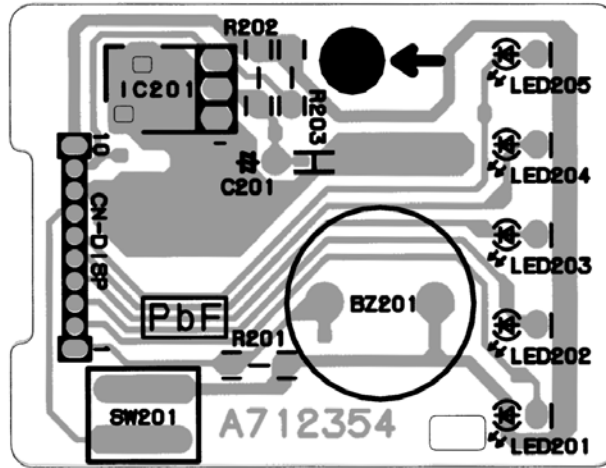

### 18.2.1. Outdoor Unit (Main)

