

Service Manual

Air Conditioner



Indoor Unit
CS-RE9JKE
CS-RE12JKE
CS-RE15JKE

Outdoor Unit
CU-RE9JKE
CU-RE12JKE
CU-RE15JKE



WARNING

This service information is designed for experienced repair technicians only and is not designed for use by the general public. It does not contain warnings or cautions to advise non-technical individuals of potential dangers in attempting to service a product. Products powered by electricity should be serviced or repaired only by experienced professional technicians. Any attempt to service or repair the products dealt with in this service information by anyone else could result in serious injury or death.

TABLE OF CONTENTS

1. Safety Precautions	3	9. Printed Circuit Board	19
2. Specification	5	10. Installation Instruction	23
2.1 CS-RE9JKE CU-RE9JKE	5	10.1 Select the Best Location	23
2.2 CS-RE12JKE CU-RE12JKE	7	10.2 Indoor Unit.....	24
2.3 CS-RE15JKE CU-RE15JKE	9	10.3 Outdoor Unit.....	26
3. Features	11	11. Service Mode	29
4. Location of Controls and Components	12	11.1 Auto OFF/ON Button	29
4.1 Indoor Unit.....	12	11.2 Select Remote Control Transmission Code	29
4.2 Outdoor Unit.....	12	11.3 Operate and Display of Remote Control ...	30
4.3 Remote Control	12	12. Operation Control	32
5. Dimensions	13	12.1 Basic Function.....	32
5.1 Indoor Unit.....	13	12.2 Indoor Fan Motor Operation.....	33
5.2 Outdoor Unit.....	14	12.3 Outdoor Fan Motor Operation	33
6. Refrigeration Cycle Diagram	15	13. Protection control	36
7. Block Diagram	16	13.1 Protection Control For All Operations	36
8. Wiring Connection Diagram	17	13.2 Protection Control For Cooling and Soft Dry Operation.....	37
		13.3 Outdoor Air Temperature Control.....	38

14. Troubleshooting Guide	40
14.1 Refrigeration Cycle System	40
14.2 Break Down self Diagnosis Function.....	40
15. Disassembly and Assembly Instructions	43
16. Exploded View and Replacement Pars List...46	
16.1 Indoor Unit	46
16.2 Outdoor Unit	48

1. Safety Precautions

- Read the following “SAFETY PRECAUTIONS” carefully before perform any servicing.
- Electrical work must be installed or serviced by a licensed electrician. Be sure to use the correct rating of the power plug and main circuit for the model installed.
- The caution items stated here must be followed because these important contents are related to safety. The meaning of each indication used is as below. Incorrect installation or servicing due to ignoring of the instruction will cause harm or damage, and the seriousness is classified by the following indications.







	WARNING	This indication shows the possibility of causing death or serious injury
	CAUTION	This indication shows the possibility of causing injury or damage to properties.













- The items to be followed are classified by the symbols:

	Symbol with white background denotes item that is PROHIBITED from doing.
	Symbol with dark background denotes item that must be carried out.

- Carry out test run to confirm that no abnormality occurs after the servicing. Then, explain to user the operation, care and maintenance as stated in instructions. Please remind the customer to keep the operating instructions for future reference.

WARNING	
	1. Engage dealer or specialist for installation. If installation done by the user is defective, it will cause water leakage, electrical shock or fire.
	2. Install according to this installation instructions strictly. If installation is defective, it will cause water leakage, electrical shock or fire.
	3. Use the attached accessories parts and specified parts for installation. Otherwise, it will cause the set to fall, water leakage, fire or electrical shock.
	4. Install at a strong and firm location which is able to withstand the set's weight. If the strength is not enough or installation is not properly done, the set will drop and cause injury.
	5. Do not install outdoor unit near handrail of veranda. When installing air-conditioner unit at veranda of high rise building, child may climb up to outdoor unit and cross over the handrail and causing accident.
	6. For electrical work, follow the local national wiring standard, regulation and this installation instruction. An independent circuit and single outlet must be used. If electrical circuit capacity is not enough or defect found in electrical work, it will cause electrical shock or fire.
	7. This equipment is strongly recommended to be installed with Earth Leakage Circuit Breaker (ELCB) or Residual Current Device (RCD). Otherwise, it may cause electrical shock and fire in case equipment breakdown or insulation breakdown.
	8. This equipment must be properly earthed. Earth line must not be connected to gas pipe, water pipe, earth of lightning rod and telephone. Otherwise, it may cause electrical shock in case equipment breakdown or insulation breakdown.
	9. Use the specified cable (1.5 mm ²) and connect tightly for indoor/outdoor connection. Connect tightly and clamp the cable so that no external force will be acted on the terminal. If connection or fixing is not perfect, it will cause heat-up or fire at the connection.
	10. Wire routing must be properly arranged so that control board cover is fixed properly. If control board cover is not fixed perfectly, it will cause fire or electrical shock.
	11. When carrying out piping connection, take care not to let air substances other than the specified refrigerant go into refrigeration cycle. Otherwise, it will cause lower capacity, abnormal high pressure in the refrigeration cycle, explosion and injury.
	12. Do not damage or use unspecified power supply cord. Otherwise, it will cause fire or electrical shock.
	13. Do not modify the length of the power supply cord or use extension cord, and do not share the single outlet with other electrical appliances. Otherwise, it will cause fire or electrical shock.
	14. • For R410A models, when connecting the piping, do not use any existing (R22) pipes and flare nuts. Using such same may cause abnormally high pressure in the refrigeration cycle (piping), and possibly result in explosion and injury. Use only R410A materials. • Thickness of copper pipes used with R410A must be more than 0.8 mm. Never use copper pipes thinner than 0.8 mm • It is desirable that the amount of residual oil is less than 40 mg/10 m.
	15. During installation, before run the compressor, confirm the refrigeration pipes are fixed. Operation of compressor without fixing the piping, setting the 2 way valve and 3-way valve at open condition, a burst may occur and cause injury.
	16. During pump down operation, stop the compressor before remove the refrigeration piping. When remove piping while 2-way valve, 3 way valve at open condition, burst may occur and cause injury.

	17. After completion of installation, confirm there is no leakage of refrigerant gas. It may generate toxic gas when the refrigerant contacts with fire.
	18. Ventilate if there is refrigerant gas leakage during operation. It may cause toxic gas when the refrigerant contacts with fire.
	19. Recommended installation height for indoor unit shall be at least 2.5 m.
	20. The appliance shall be installed in accordance with national wiring regulations.
	21. Keep away from small children, the thin film may cling to nose and mouth and prevent breathing.
	22. Do not insert your fingers or other objects into the unit, high speed rotating fan may cause injury.

 CAUTION	
	1. Do not install the unit at place where leakage of flammable gas may occur. In case gas leaks and accumulates at surrounding of the unit, it may cause fire.
	2. Carry out drainage piping as mentioned in installation instructions. If drainage is not perfect, water may enter the room and damage the furniture.
	3. Tighten the flare nut with torque wrench according to specified method. If the flare nut is over-tightened, after a long period, the flare may break and cause refrigerant gas leakage.
	4. Do not touch outdoor unit air inlet and aluminums fin. It may cause injury.
	5. Select an installation location which is easy for maintenance.
	6. Power supply connection to the air conditioner. Connect the power supply cord of the air conditioner to the mains using one of the following methods. Power supply point should be in easily accessible place for power disconnection in case of emergency. In some countries, permanent connection of this air conditioner to the power supply is prohibited. 1) Power supply connection to the receptacle using a power plug. Use an approved 15/16A power plug with earth pin for the connection to the receptacle. 2) Power supply connection to a circuit breaker for the permanent connection. Use an approved 16A circuit breaker for the permanent connection. It must be a double pole switch with a minimum 3.5 mm contact gap.
	7. Do not release refrigerant. Do not release refrigerant during piping work for installation, re-installation and during repairing a refrigeration parts. Take care of the liquid refrigerant, it may cause frostbite.
	8. Installation work. It may need two people to carry out the installation work.
	9. Do not install this appliance in a laundry room or other location where water may drip from the ceiling, etc.
	10. Do not sit or step on the unit, you may fall down accidentally.
	11. Do not touch the sharp aluminium fin, sharp parts may cause injury.
	12. Thermal fuse specification for indoor unit: 250V 3.15A T3.15AL; outdoor unit: 205V 3.15A T3.15AL, 205V 20A T20AL.

2. Specification

2.1 CS-RE9JKE CU-RE9JKE

Item		Unit	Indoor Unit	Outdoor Unit	
COOLING	Capacity	kW	2.50(0.90~3.00)		
		BTU/h	8530(3070~10230)		
	EER	W/W	3.57(4.74~3.00)		
		BTU/hW	12.18(16.16~10.23)		
	Noise Level	dB(A)	Hi: 42 Lo: 27 QLo: 22	Hi: 47	
Power level dB		53	60		
HEATING	Capacity	kW	3.30(0.90~4.10)		
		BTU/h	11250(3070~13980)		
	COP	W/W	4.02(5.29~3.57)		
		BTU/hW	13.71(18.06~12.16)		
	Noise Level	dB(A)	Hi: 42 Lo: 27 QLo: 25	Hi: 48	
Power level dB		53	61		
Moisture Removal		l/h	1.4		
		(pt/h)	2.4		
Air Volume	Lo	m ³ /m (ft ³ /m)	8.51 (300)	-	
	Me	m ³ /m (ft ³ /m)	10.81 (381)	-	
	Hi	m ³ /m (ft ³ /m)	13.8 (487)	28.9 (1020)	
Refrigerant Control Device			-	Capillary Tube	
Refrigerant Oil (Charged)		cm ³	-	RB68A or Freol Alpha68M	
Refrigerant (Charged) R410A		kg (oz)	-	0.81 (28.5)	
Dimension	Height	mm (inch)	290 (11-15/32)	540 (21-1/4)	
	Width	mm (inch)	848 (33-13/32)	780 (30-23/32)	
	Depth	mm (inch)	204 (8-1/32)	289 (11-3/8)	
Net Weight		kg (lbs)	9.0 (20)	28 (62)	
Pipe Diameter	Gas	mm (inch)	9.52 (3/8)		
	Liquid	mm (inch)	6.35 (1/4)		
Pipe Length		m (ft)	3 (9.8) - 15(49.2)		
Height Difference		m (ft)	5 (16.4)		
Additional Gas Amount		g/m (oz/ft)	20 (0.2)		
Refrigerant Charge Less		m (ft)	7.5 (24.6)		
Drain Hose	Inner diameter	mm	14	-	
	Length	mm	500	-	
Compressor	Type		-	Rotary	
	Motor Type		-	Induction (6-poles)	
	Rated Output	W	-	750	
Fan	Type		Cross-Flow Fan	Propeller Fan	
	Material		AS	PP	
	Motor Type		Induction (8-poles)	Induction (6-poles)	
	Input power	W	-	-	
	Output power	W	30	15	
	Fan Speed	Lo	rpm	740	-
		Me	rpm	940	-
Hi		rpm	1200	750	
Heat Exchanger	Fin material		Aluminium (Pre Coated)	Aluminum (Pre Coated)	
	Fin type		Slit Fin	Slit Fin	
	Row x stage x FPI		2 x 15 x 19	1 x 24 x 17	
	Size (W x H x L)	mm	610 x 315 x 25.4	709 x 504 x 18.2	
Air Filter Type	Material		P.P.HONEY COMB	-	
	Style		One-Touch	-	

1. Cooling capacities are based on indoor temperature of 27°C Dry Bulb (80.6°F Dry Bulb), 19°C Wet Bulb (66.2°F Wet Bulb) and outdoor air temperature of 35°C Dry Bulb (95.0°F Dry Bulb), 24°C Wet Bulb (75.2°F Wet Bulb).
2. Heating capacities are based on indoor temperature of 20°C Dry Bulb (80.6°F Dry Bulb) and outdoor air temperature of 7°C Dry Bulb (44.6°F Dry Bulb), 6°C Wet Bulb (42.8°F Wet Bulb).

Item		Unit	
Power Source (Phase, Voltage, Cycle)		φ	Single
		V	230
		Hz	50
Input Power	COOLING	W	700(190~1000)
	HEATING	W	820(170~1150)
Starting Current		A	3.70
Running Current	COOLING	A	3.45
	HEATING	A	3.70
Maximum Current		A	6.00
Power Factor	COOLING	%	88
	HEATING	%	96
Power factor means total figure of compressor, indoor fan motor and outdoor fan motor.			
Power Cord	Number of core		3 (1.5mm)
	Length	m	1.9
Thermostat			Electronic Control
Protection Device			Electronic Control

Note

Specification is subject to change without prior notice for further improvement.

2.2 CS-RE12JKE CU-RE12JKE

Item		Unit	Indoor Unit	Outdoor Unit	
COOLING	Capacity	kW	3.50(0.90~3.90)		
		BTU/h	11940(3070~13300)		
	EER	W/W	3.47(5.29~3.25)		
		BTU/hW	11.82(18.06~11.08)		
	Noise Level	dB(A)	Hi: 42 Lo: 30 QLo: 22	Hi: 48	
Power level dB		Hi: 53 Lo: -	Hi: 61		
HEATING	Capacity	kW	4.25(0.90~5.10)		
		BTU/h	14490(3070~17390)		
	COP	W/W	3.79(6.00~3.49)		
		BTU/hW	12.94(20.47~11.91)		
	Noise Level	dB(A)	Hi: 42 Lo: 33 QLo: 28	Hi: 50	
Power level dB		Hi: 53 Lo: -	Hi: 63		
Moisture Removal		l/h	2.0		
		(pt/h)	3.5		
Air Volume	Lo	m ³ /m (ft ³ /m)	9.6 (338)	-	
	Me	m ³ /m (ft ³ /m)	11.6 (409)	-	
	Hi	m ³ /m (ft ³ /m)	13.8 (487)	30.5 (1076)	
Refrigerant Control Device			-	Capillary Tube	
Refrigerant Oil (Charged)		cm ³	-	RB68A or Freol Alpha68M	
Refrigerant (Charged) R410A		kg (oz)	-	0.97 (34.2)	
Dimension	Height	mm (inch)	290 (11-15/32)	540 (21-1/4)	
	Width	mm (inch)	848 (33-13/32)	780(30-23/32)	
	Depth	mm (inch)	204 (8-1/32)	289 (11-3/8)	
Net Weight		kg (lbs)	9.0 (20)	30 (66)	
Pipe Diameter	Gas	mm (inch)	9.52 (3/8)		
	Liquid	mm (inch)	6.35 (1/4)		
Pipe Length		m (ft)	3 (9.8) - 15 (49.2)		
Height Difference		m (ft)	5 (16.4)		
Additional Gas Amount		g/m (oz/ft)	20 (0.2)		
Refrigerant Charge Less		m (ft)	7.5 (24.6)		
Drain Hose	Inner diameter	mm	14	-	
	Length	mm	500	-	
Compressor	Type		-	Rotary	
	Motor Type		-	Induction (6-poles)	
	Rated Output	W	-	900	
Fan	Type		Cross-Flow Fan	Propeller Fan	
	Material		AS	PP	
	Motor Type		Induction (8-poles)	Induction (6-poles)	
	Input power	W	-	-	
	Output power	W	30	25	
	Fan Speed	Lo (Cool)	rpm	840	-
		Me (Cool)	rpm	1020	-
Hi (Cool)		rpm	1210	870	
Heat Exchanger	Fin material		Aluminum (Pre Coated)	Aluminum (Pre Coated)	
	Fin type		Slit Fin	Slit Fin	
	Row x stage x FPI		2 x 15 x 19	2 x 24 x 17	
	Size (W x H x L)	mm	610 x 315 x 25.4	709 x 540 x 36.4	
Air Filter Type	Material		P.P.HONEY.COMP	-	
	Style		One-Touch	-	

1. Cooling capacities are based on indoor temperature of 27°C Dry Bulb (80.6°F Dry Bulb), 19°C Wet Bulb (66.2°F Wet Bulb) and outdoor air temperature of 35°C Dry Bulb (95.0°F Dry Bulb), 24°C Wet Bulb (75.2°F Wet Bulb).

2. Heating capacities are based on indoor temperature of 20°C Dry Bulb (80.6°F Dry Bulb) and outdoor air temperature of 7°C Dry Bulb (44.6°F Dry Bulb), 6°C Wet Bulb (42.8°F Wet Bulb).

Item		Unit	
Power Source (Phase, Voltage, Cycle)			Single
		V	230
		Hz	50
Input Power	COOLING	W	1010(170~1200)
	HEATING	W	1120(150~1460)
Starting Current		A	5.20
Running Current	COOLING	A	4.70
	HEATING	A	5.20
Maximum Current		A	6.80
Power Factor	COOLING		93
	HEATING	%	93
Power factor means total figure of compressor, indoor fan motor and outdoor fan motor.			
Power Cord	Number of core		3 (1.5mm)
	Length	m	1.9
Thermostat			Electronic Control
Protection Device			Electronic Control

Note

Specification is subject to change without prior notice for further improvement.

2.3 CS-RE15JKE CU-RE15JKE

Item		Unit	Indoor Unit	Outdoor Unit	
COOLING	Capacity	kW	4.20(1.00~4.60)		
		BTU/h	14330(3410~15700)		
	EER	W/W	3.33(4.76~2.87)		
		BTU/hW	11.37(16.23~9.81)		
	Noise Level	dB(A)	Hi: 46 Lo: 31 QLo: 29	Hi: 50	
Power level dB		Hi: 57 Lo: -	Hi: 63		
HEATING	Capacity	kW	5.30(0.90~7.60)		
		BTU/h	18080(3070~25930)		
	COP	W/W	3.44(4.28~3.16)		
		BTU/hW	11.74(14.61~10.80)		
	Noise Level	dB(A)	Hi: 47 Lo: 34 QLo: 28	Hi: 51	
Power level dB		Hi: 58 Lo: -	Hi: 64		
Moisture Removal		l/h	2.4		
		(pt/h)	4.2		
Air Volume	Lo	m ³ /m (ft ³ /m)	10.3 (363)	-	
	Me	m ³ /m (ft ³ /m)	12.2 (430)	-	
	Hi	m ³ /m (ft ³ /m)	14.4 (508)	31 (1094)	
Refrigerant Control Device			-	Expansion Valve	
Refrigerant Oil (Charged)		cm ³	-	RB68A or Freol Alpha68M / (400)	
Refrigerant (Charged) R410A		kg (oz)	-	0.97 (34.2)	
Dimension	Height	mm (inch)	290 (11-15/32)	540 (21-1/4)	
	Width	mm (inch)	848 (33-13/32)	780(30-23/32)	
	Depth	mm (inch)	204 (8-1/32)	289 (11-3/8)	
Net Weight		kg (lbs)	9.0 (20)	3 (79)	
Pipe Diameter	Gas	mm (inch)	12.70 (1/2)		
	Liquid	mm (inch)	6.35 (1/4)		
Pipe Length		m (ft)	3 (9.8) - 15 (49.2)		
Height Difference		m (ft)	5 (16.4)		
Additional Gas Amount		g/m (oz/ft)	20 (0.2)		
Refrigerant Charge Less		m (ft)	7.5 (24.6)		
Drain Hose	Inner diameter	mm	14	-	
	Length	mm	500	-	
Compressor	Type		-	Scroll	
	Motor Type		-	Burshless motor (4-poles)	
	Rated Output	W	-	900	
Fan	Type		Cross-Flow Fan	Propeller Fan	
	Material		AS	PP	
	Motor Type		Induction (8-poles)	Induction (8-poles)	
	Input power	W	-	-	
	Output power	W	30	40	
	Fan Speed	Lo (Cool)	rpm	890	-
		Me (Cool)	rpm	1050	-
Hi (Cool)		rpm	1240	830	
Heat Exchanger	Fin material		Aluminum (Pre Coated)	Aluminum (Pre Coated)	
	Fin type		Slit Fin	Slit Fin	
	Row x stage x FPI		2 x 15 x 20	2 x 20 x 19	
	Size (W x H x L)	mm	610 x 315 x 25.4	813 x 508 x 44	
Air Filter Type	Material		P.P.HONEY.COMP	-	
	Style		One-Touch	-	

1. Cooling capacities are based on indoor temperature of 27°C Dry Bulb (80.6°F Dry Bulb), 19°C Wet Bulb (66.2°F Wet Bulb) and outdoor air temperature of 35°C Dry Bulb (95.0°F Dry Bulb), 24°C Wet Bulb (75.2°F Wet Bulb).
2. Heating capacities are based on indoor temperature of 20°C Dry Bulb (80.6°F Dry Bulb) and outdoor air temperature of 7°C Dry Bulb (44.6°F Dry Bulb), 6°C Wet Bulb (42.8°F Wet Bulb).

Item		Unit	
Power Source (Phase, Voltage, Cycle)			Single
		V	230
		Hz	50
Input Power	COOLING	W	1260 (210~1600)
	HEATING	W	1540 (210~2400)
Starting Current		A	7.10
Running Current	COOLING	A	6.05
	HEATING	A	7.10
Maximum Current		A	9.70
Power Factor	COOLING		90
	HEATING	%	94
Power factor means total figure of compressor, indoor fan motor and outdoor fan motor.			
Power Cord	Number of core		3 (1.5mm)
	Length	m	1.9
Thermostat			Electronic Control
Protection Device			Electronic Control

Note

Specification is subject to change without prior notice for further improvement.

3. Features

- Inverter Technology
 - Wider output power range
 - Energy saving
 - Quick Cooling
 - More precise temperature control
- Long Installation Piping
 - CS/CU-RE9/12/15JKE, long piping up to 15 meters.
- Easy to use remote control
- Quality Improvement
 - Random auto restart after power failure for safety restart operation
 - Gas leakage protection
 - Prevent compressor reverse cycle
 - Inner protector to protect compressor
- Operation Improvement
 - Quiet mode to reduce the indoor unit operating sound
 - Powerful mode to reach the desired room temperature quickly
 - 12-hour timer
- Serviceability Improvement
 - Breakdown Self Diagnosis Function.
- SUPER ALLERU-BUSTER Filter supplied..

4. Location of Controls and Components

4.1 Indoor Unit

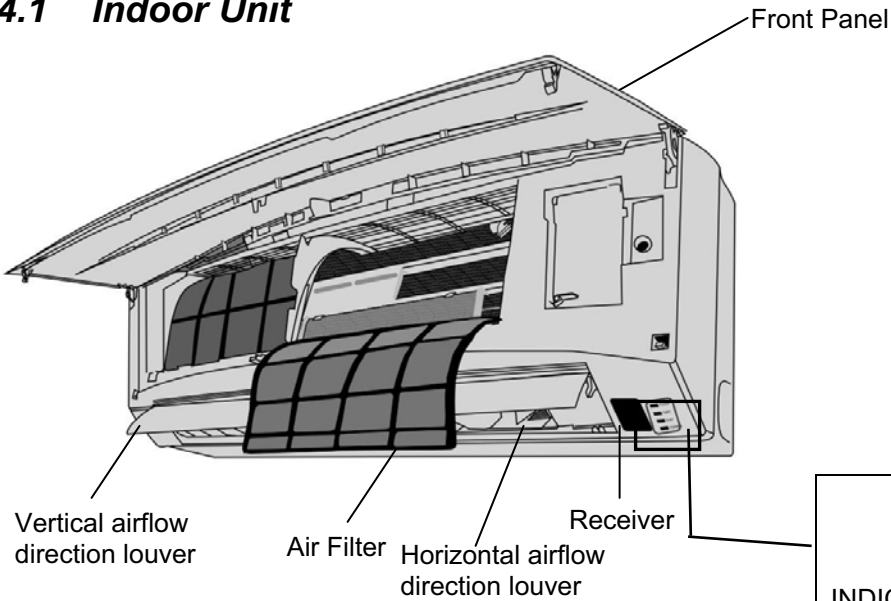

INDICATOR	POWER	GREEN
	TIMER	ORANGE
	QUIET	GREEN
	POWERFUL	RED

4.2 Outdoor Unit

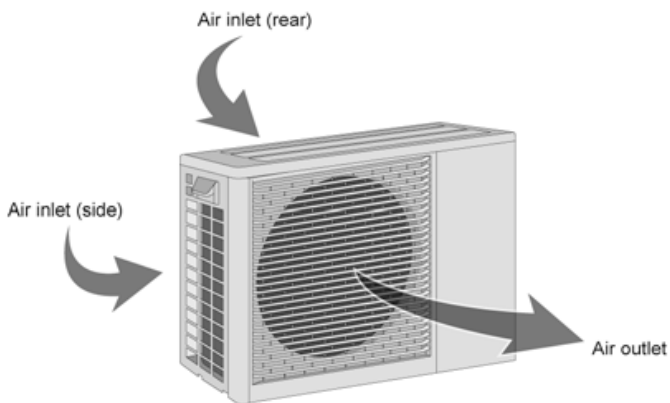

4.3 Remote Control

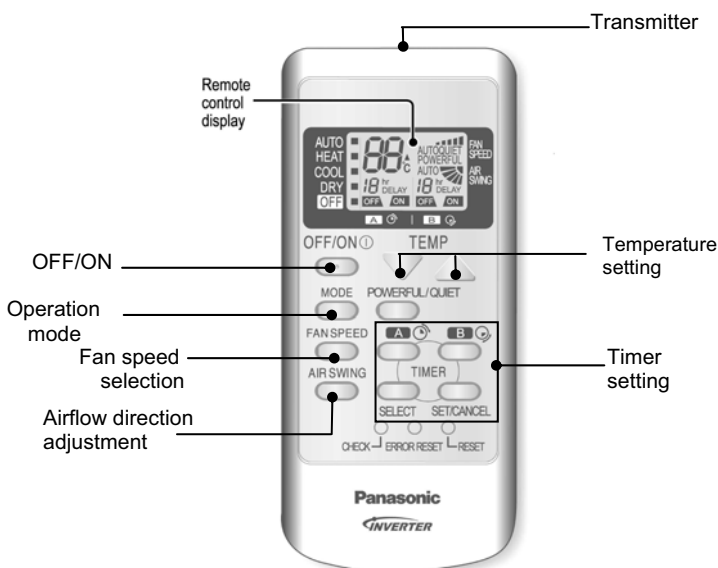

- For normal operation, the ERROR RESET button is not in use.
- Press RESET button to restore the remote control's default setting.

5. Dimensions

5.1 Indoor Unit

Unit: mm

FRONT VIEW

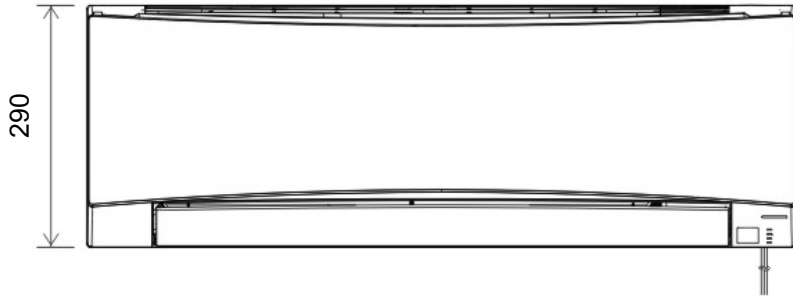

SIDE VIEW

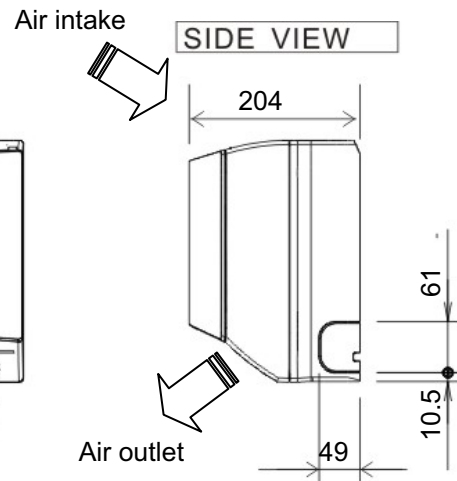

BOTTOM VIEW

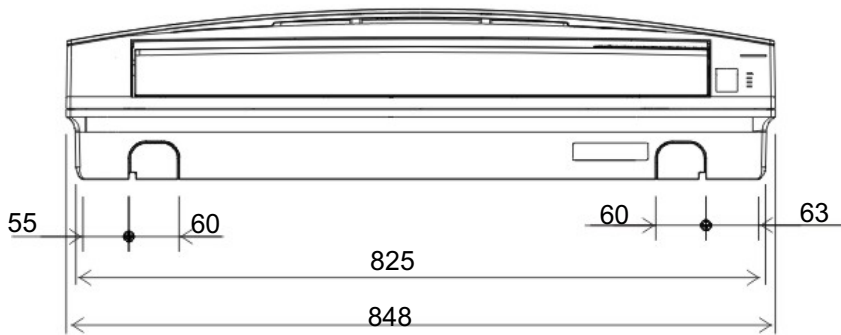

REAR VIEW

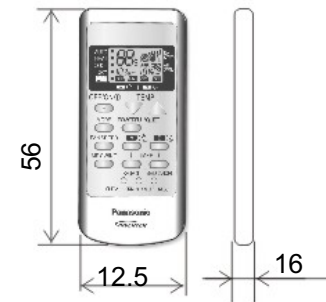
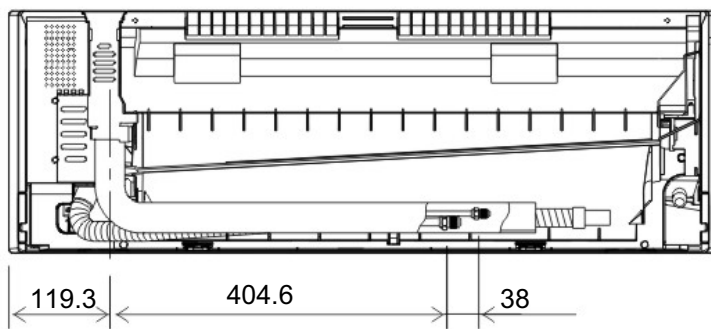

Installation plate

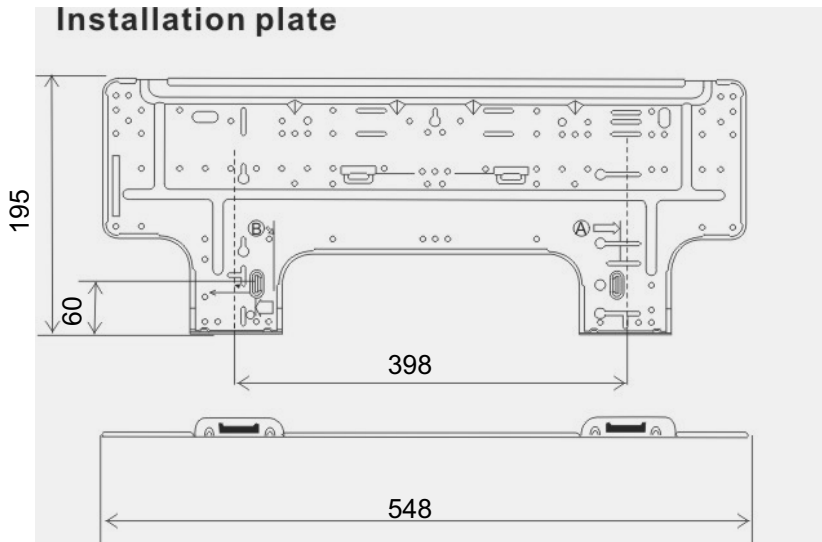

5.2 Outdoor Unit

Unit: mm

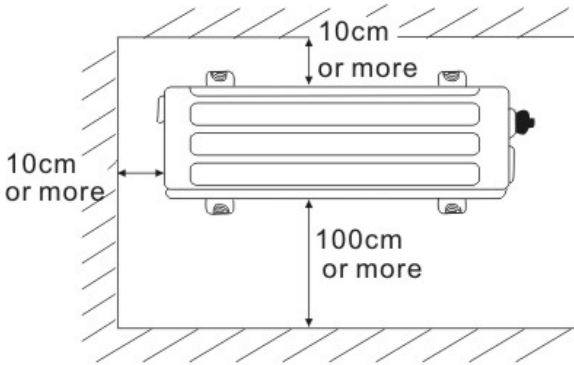

TOP VIEW

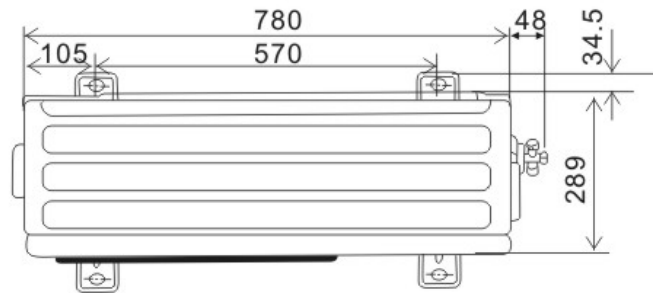

FRONT VIEW

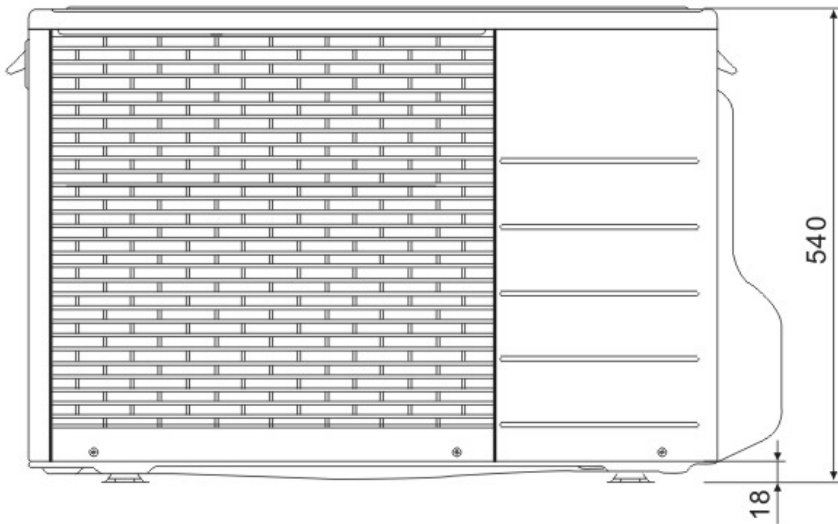

SIDE VIEW

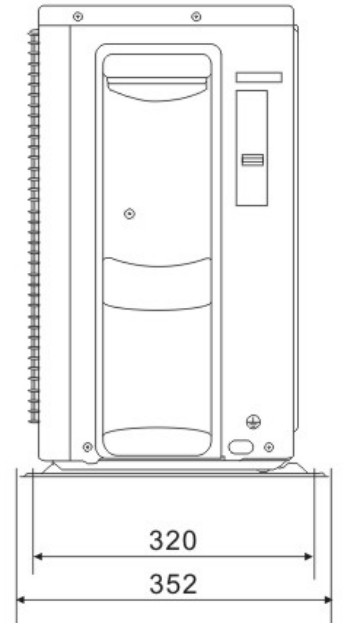

6. Refrigeration Cycle Diagram

CS/CU-RE9JKE, CS/CU-RE12JKE

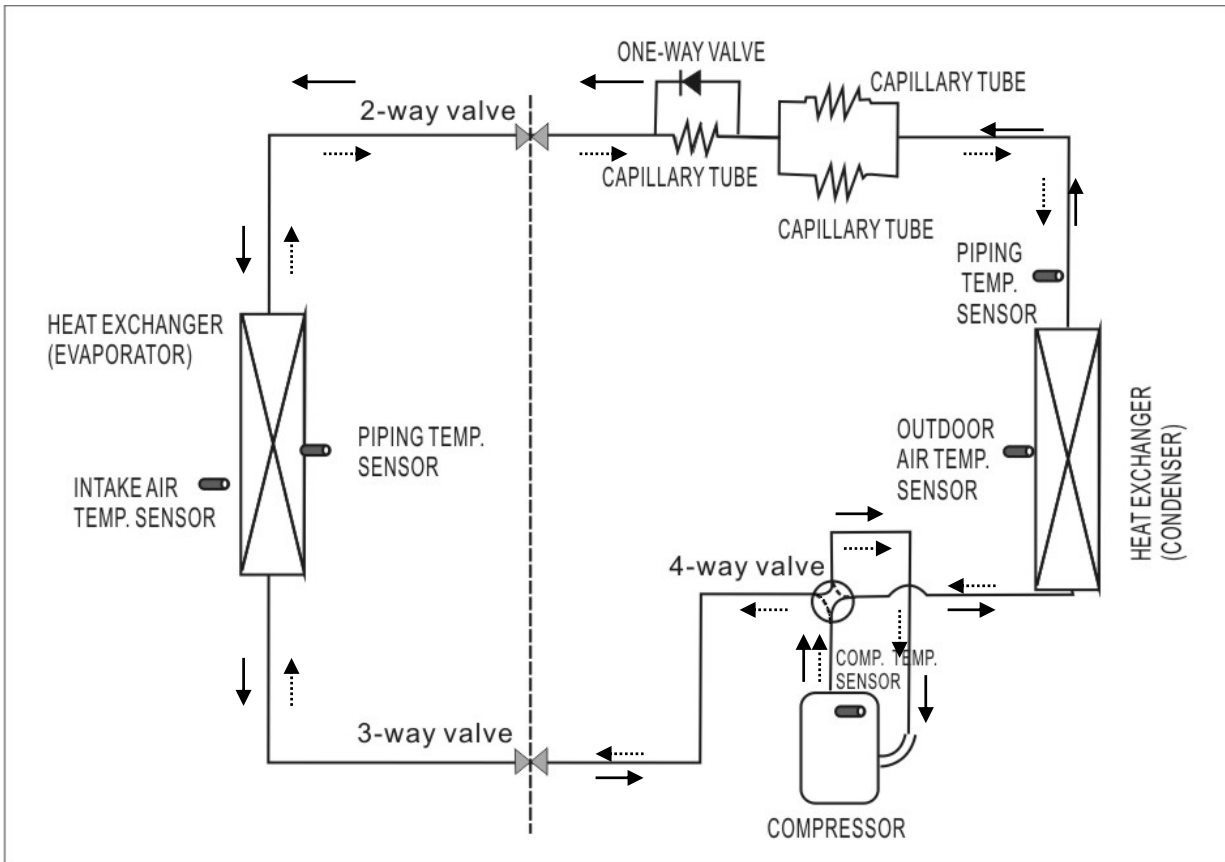

————→ COOLING

- - - - -> HEATING

CS/CU-RE15JKE

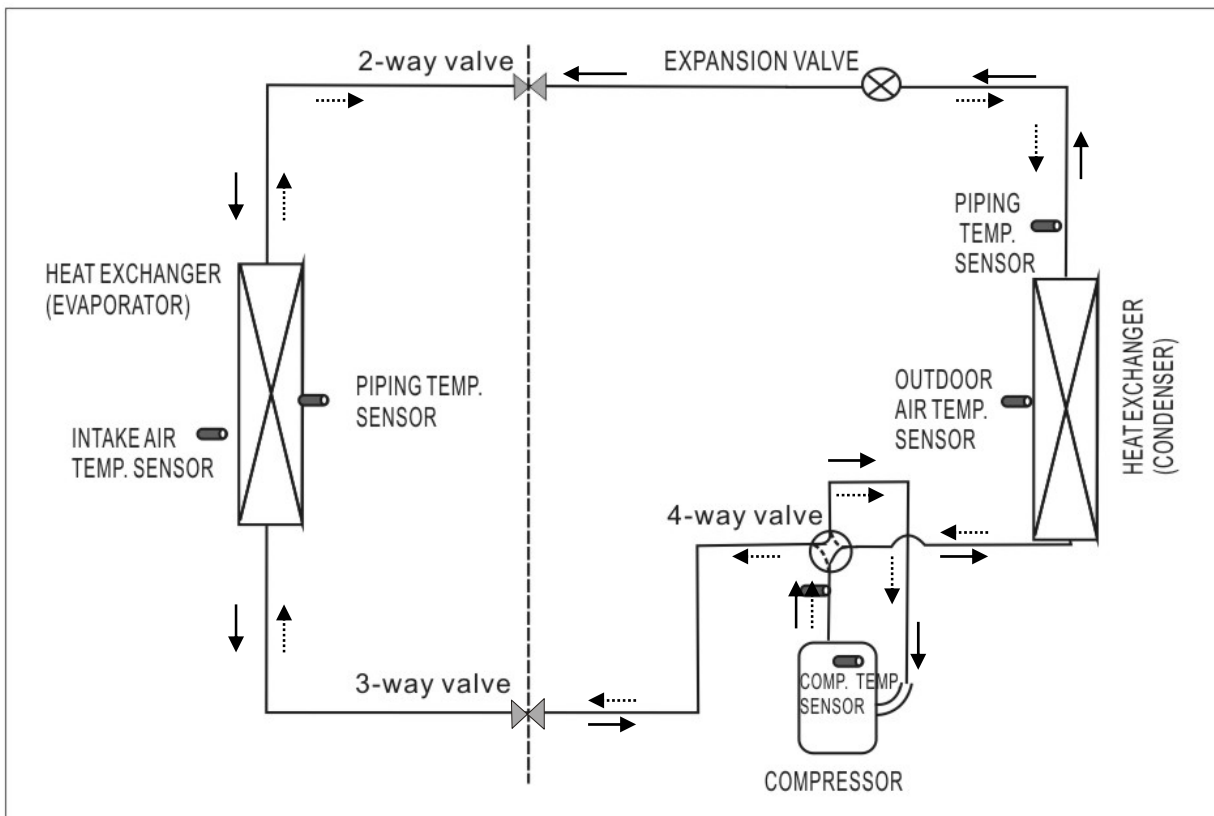

7. Block Diagram

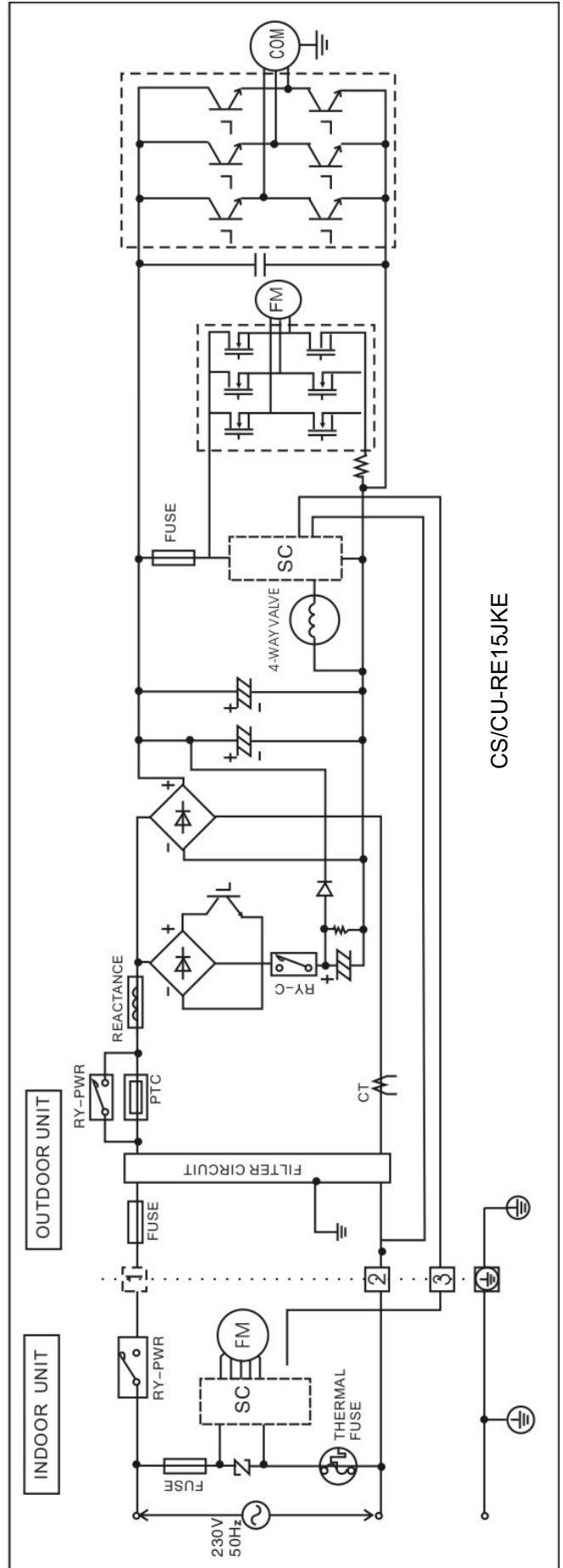
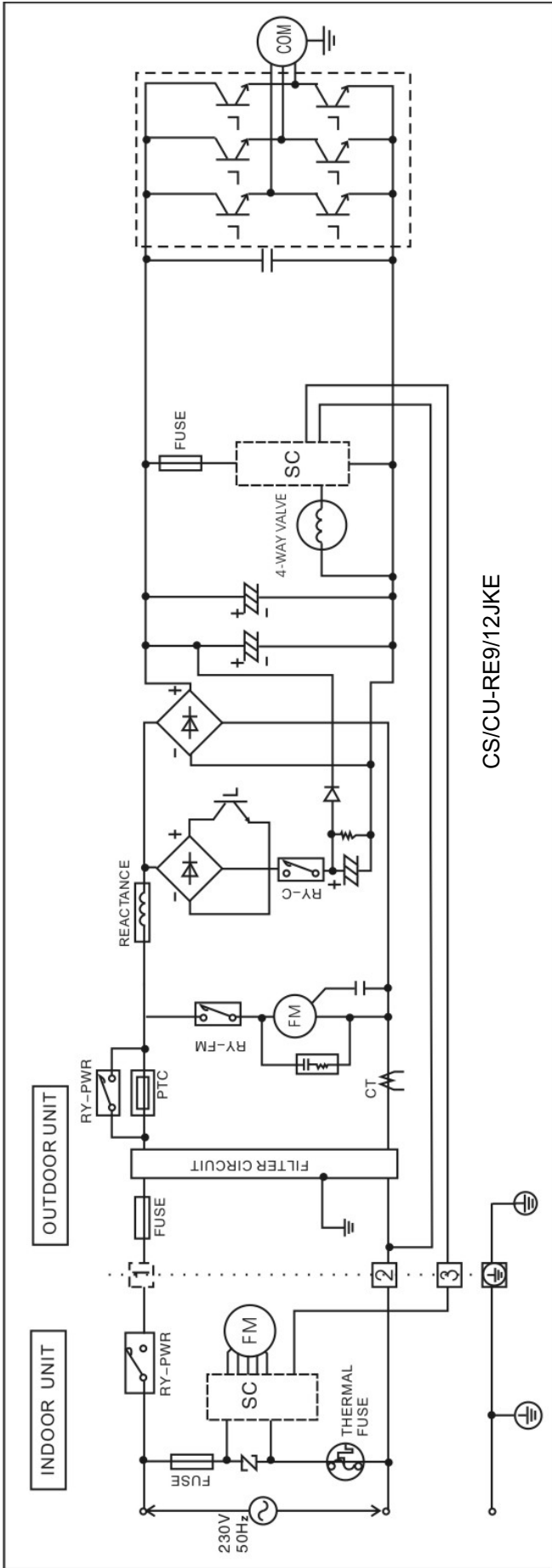

8. Wiring Diagram

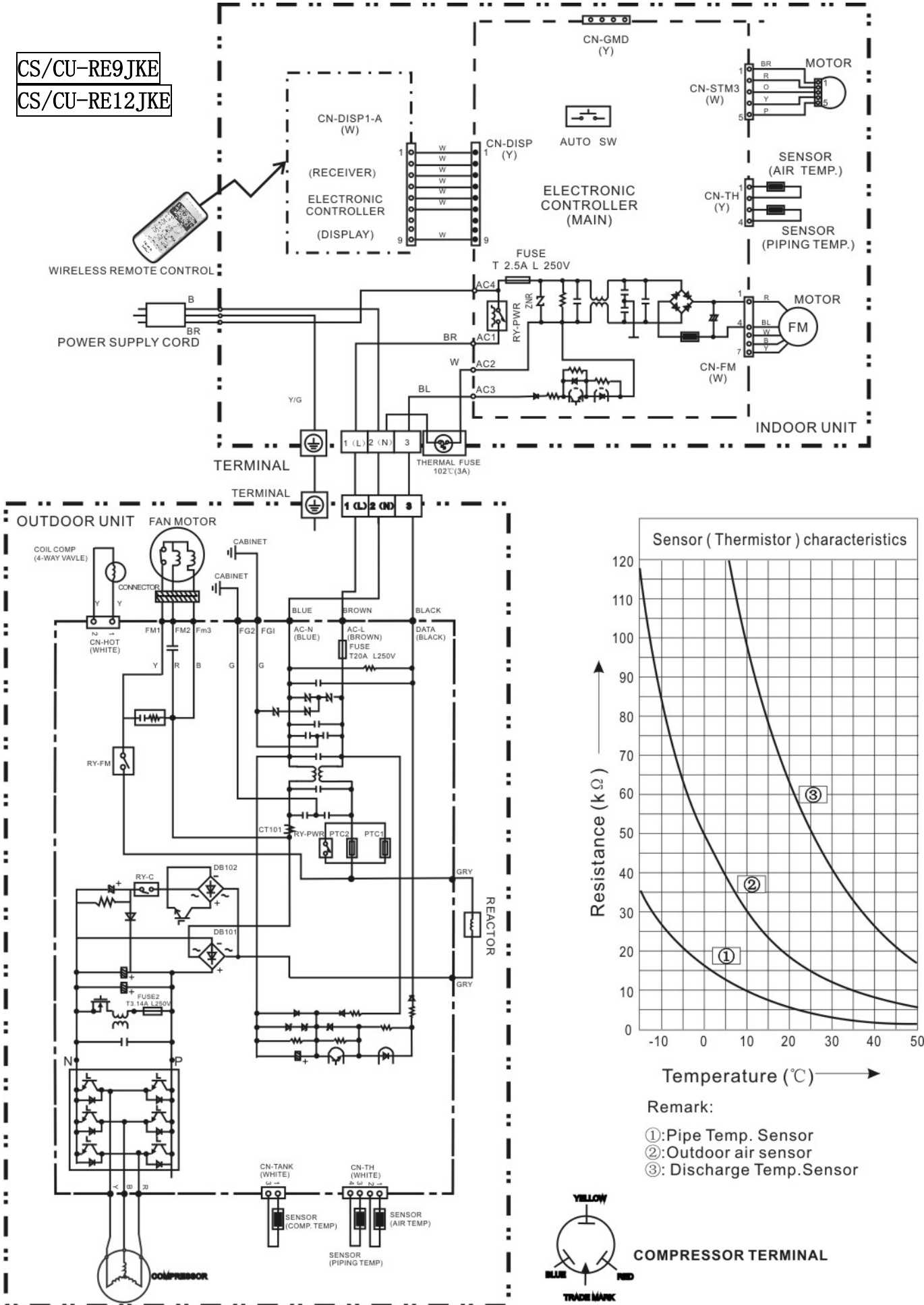

CS/CU-RE15JKE

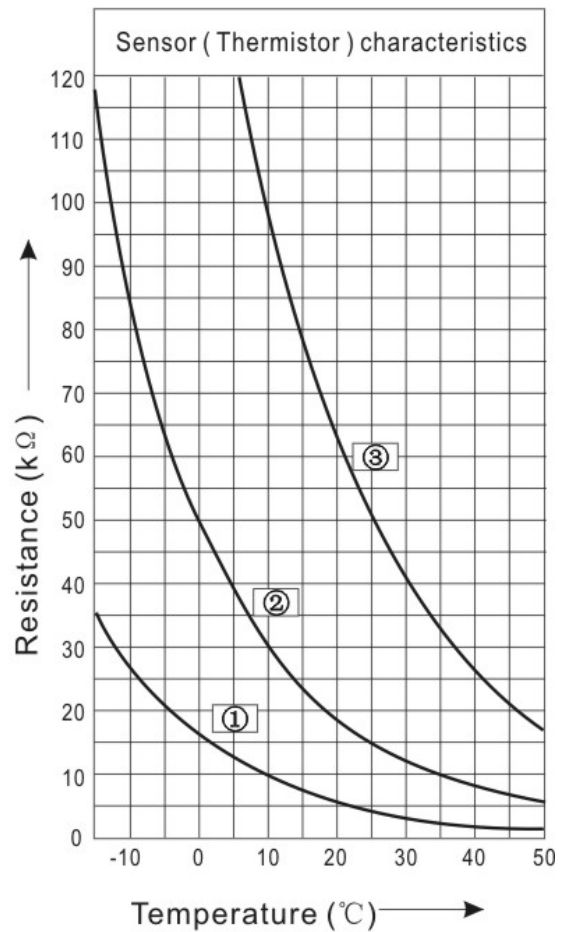
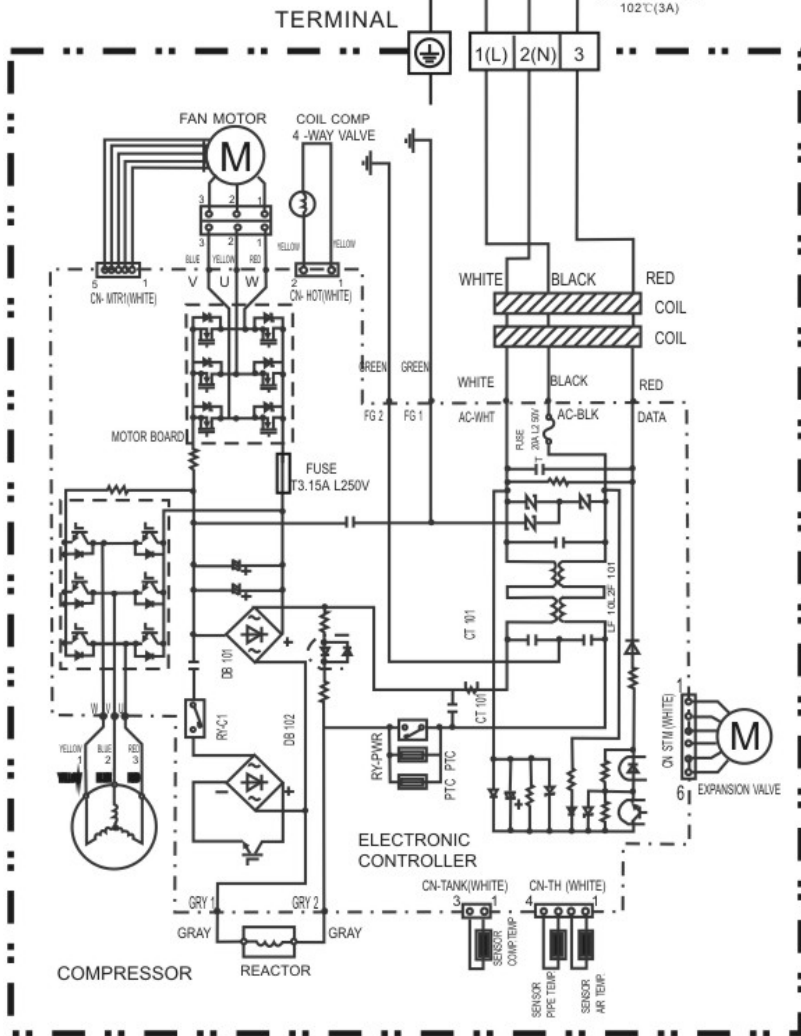
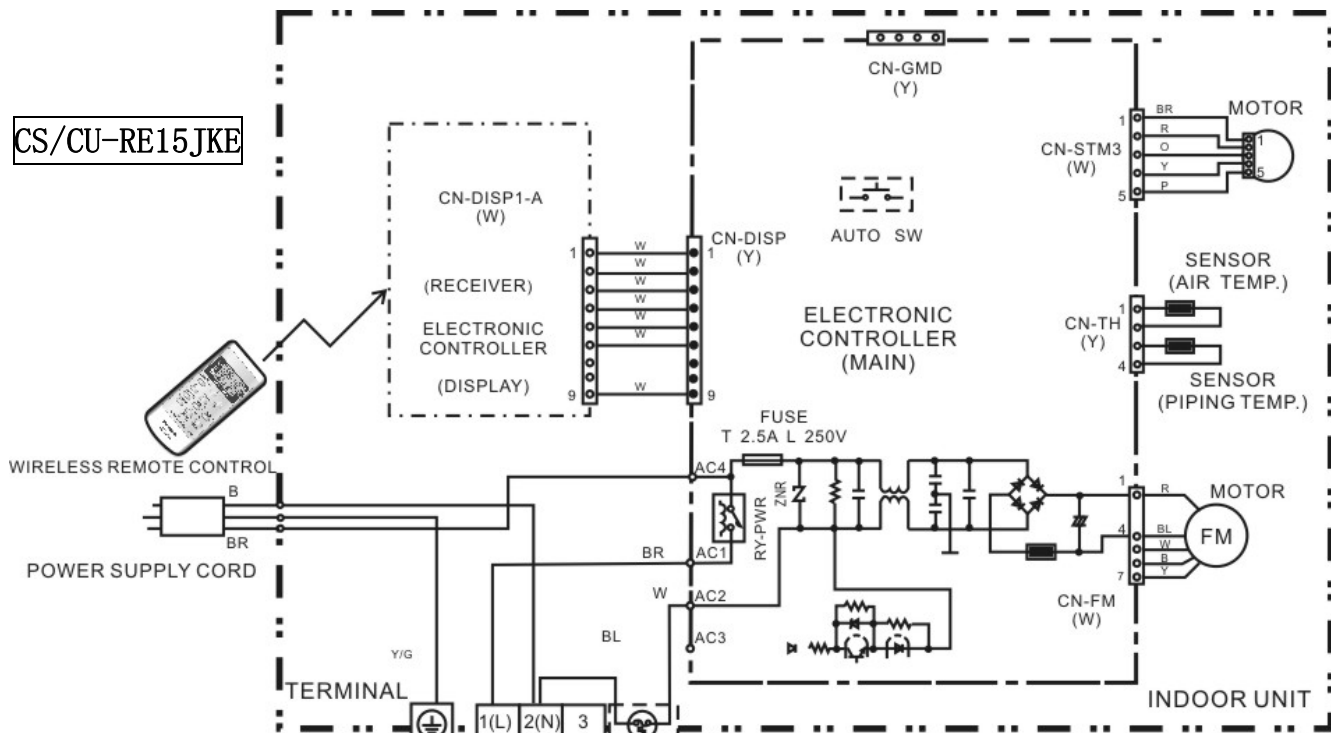

Remark:

- ①: Pipe Temp. Sensor
- ②: Outdoor air sensor
- ③: Discharge Temp. Sensor

COMPRESSOR TERMINAL

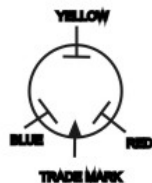

9. Printed Circuit Board

9.1 Indoor Unit

9.1.1 Main Printed Circuit Board

TOP VIEW

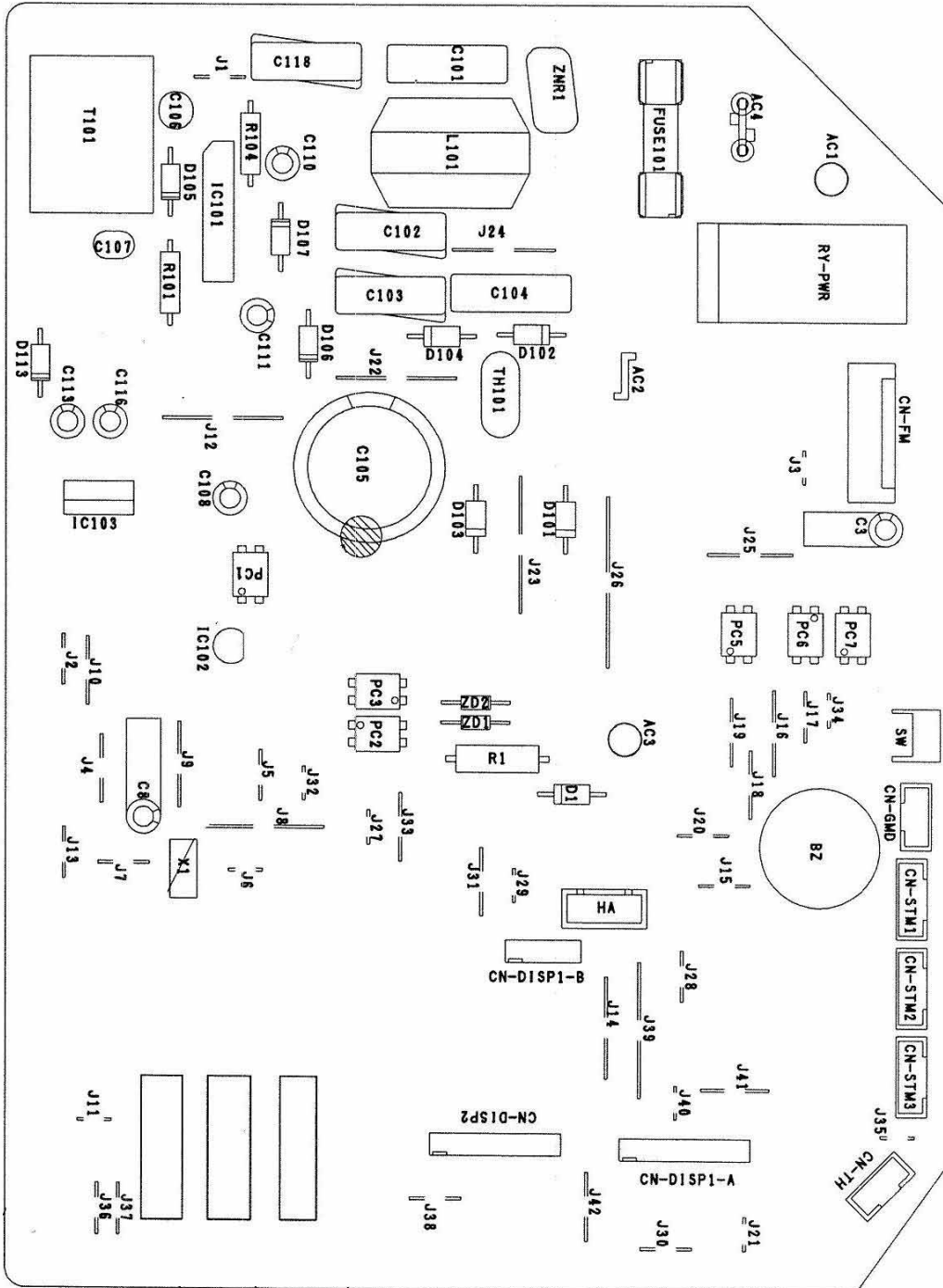

BOTTOM VIEW

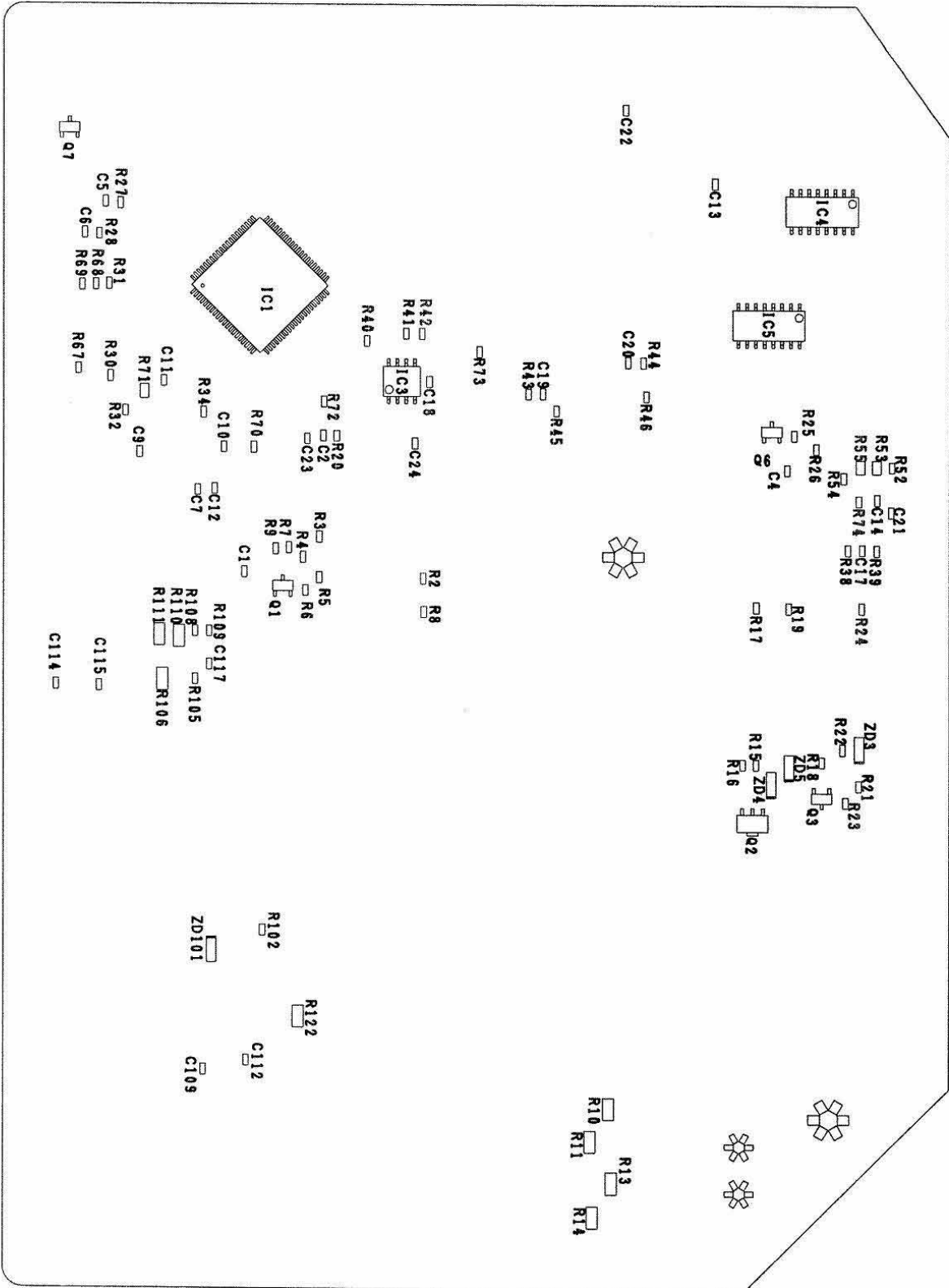

9.1.2 Indicator & receiver

TOP VIEW

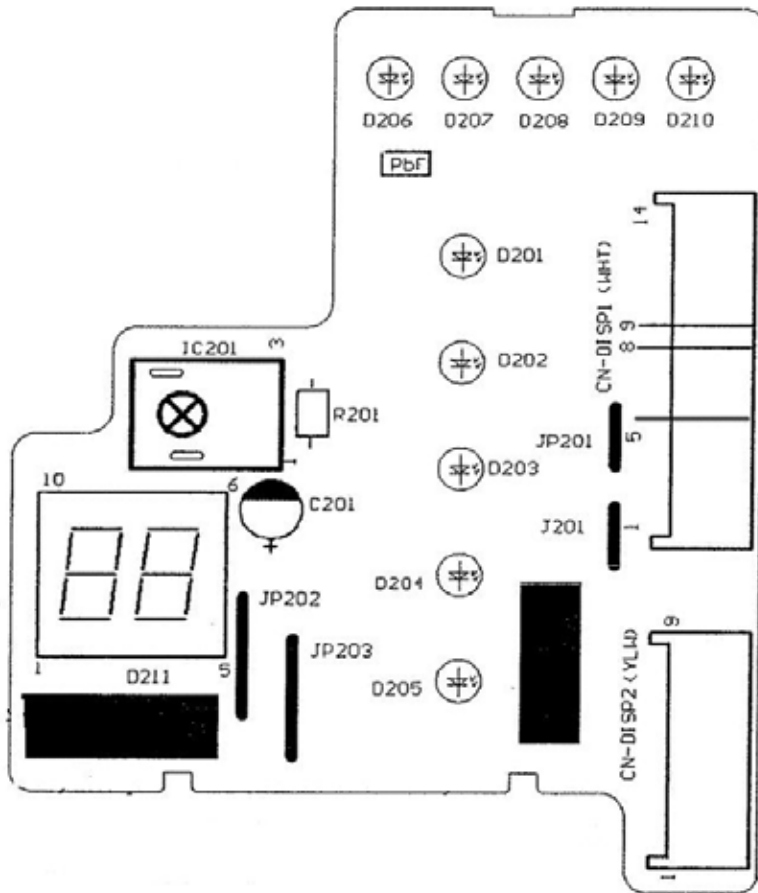

BOTTOM VIEW

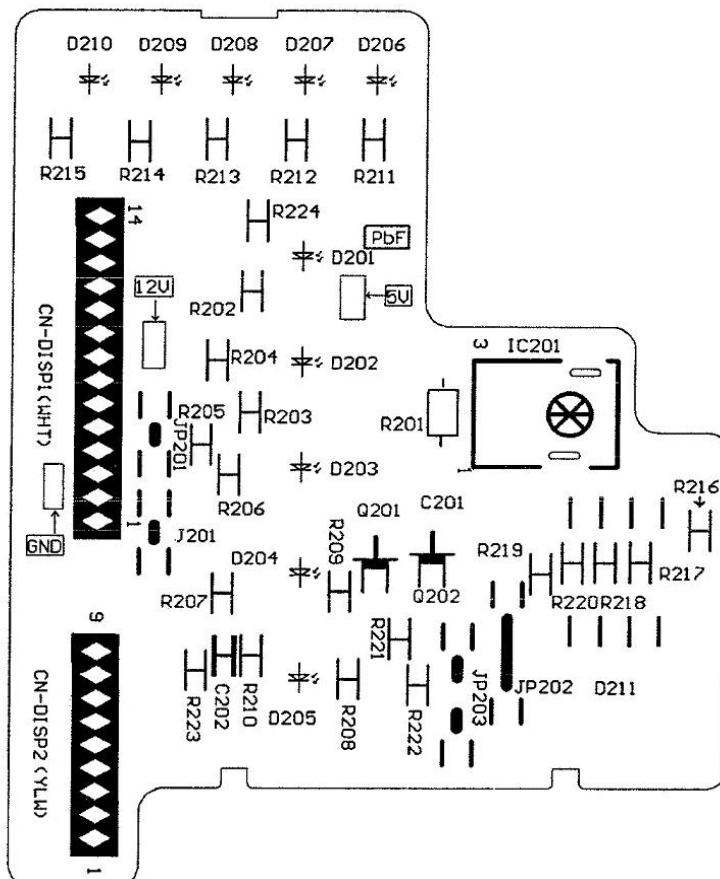

9.2 Outdoor Unit

9.2.1 CU-RE9JKE, CU-RE12JKE

TOP VIEW

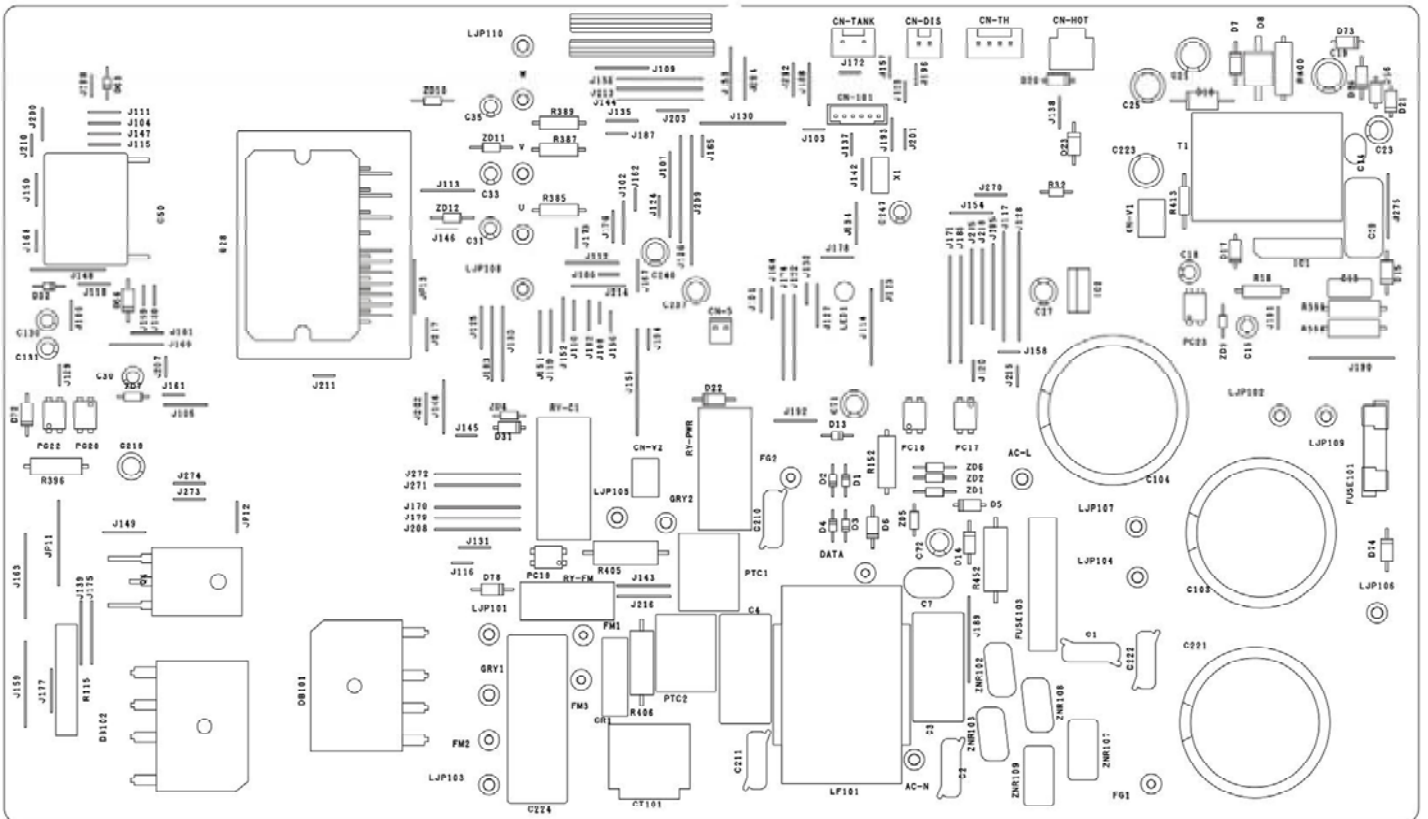

BOTTOM VIEW

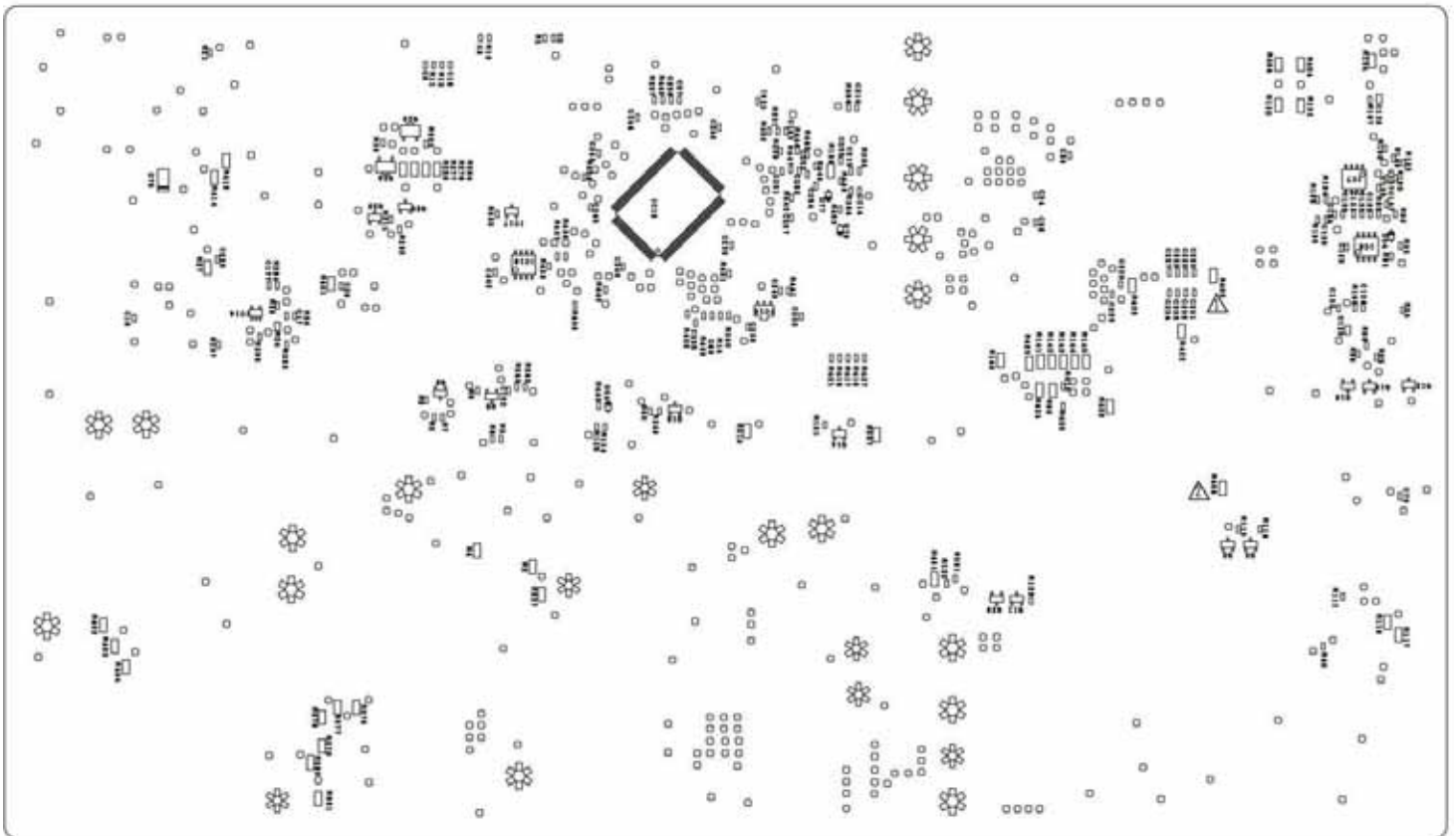

10. Installation Instruction

10.1 Select the Best Location

10.1.1 Indoor Unit

- There should not be any heat source or steam near the unit.
- There should not be any obstacles blocking the air circulation.
- A place where air circulation in the room is good.
- A place where drainage can be easily done.
- A place where noise prevention is taken into consideration.
- Do not install the unit near the door way.
- Ensure the spaces indicated by arrows from the wall, ceiling, fence or other obstacles.
- Recommended installation height for indoor unit shall be at least 2.5m.

10.1.2 Outdoor Unit

- If an awning is built over the unit to prevent direct sunlight or rain, be careful that heat radiation from the condenser is not obstructed.
- There should not be any animal or plant which could be affected by hot air discharged.
- Keep the spaces indicated by arrows from wall, ceiling, fence or other obstacles.
- Do not place any obstacles which may cause a short circuit of the discharged air.
- If piping length is over the rated length, additional refrigerant should be added as shown in the table below:

Model	Piping size		Rated Length (m)	Max Elevation (m)	Min Piping Length (m)	Max Piping Length (m)	Additional Refrigerant (g/m)
	Gas	Liquid					
RE9JKE	3/8"	1/4"	7.5	5	3	15	20
RE12JKE	3/8"	1/4"	7.5	5	3	15	20
RE15JKE	1/2"	1/4"	7.5	5	3	15	20

Example: If the unit is installed at a 10m distance, the quantity of additional refrigerant should be 50 g. (10-7.5) m x 20g/m = 50 g

11.1.3 Indoor/Outdoor Unit

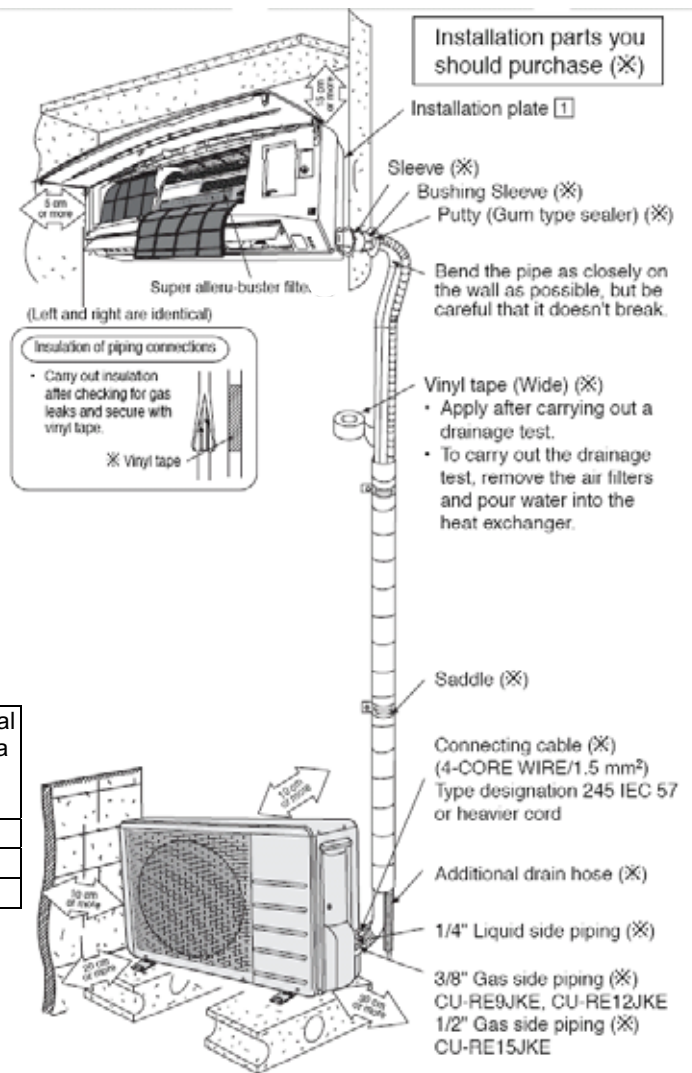
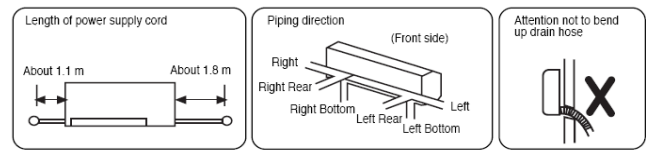

*This illustration is for explanation purposes only. The indoor unit will actually face a different way.

10.2 Indoor Unit

10.2.1 How to Fix Installation Plate

The mounting wall is strong and solid enough to prevent it from the vibration.

The centre of installation plate should be at more than 450 mm at right and left of the wall.

The distance from installation plate edge to ceiling should more than 75mm.

From installation plate left edge to unit's left side is 148 mm.

From installation plate right edge to unit's right side is 152 mm.

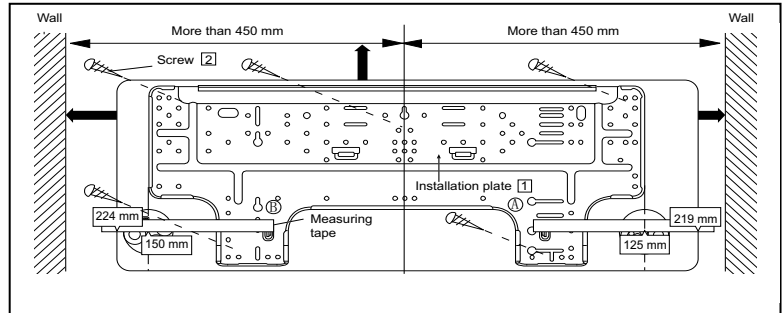

- Ⓑ : For left side piping, piping connection for gas should be about 45 mm from this line.
 : For left side piping, piping connection cable should be about 800 mm from this line.

- 1 Mount the installation plate on the wall with 5 screws or more. (If mounting the unit on the wall, consider using anchor bolts.) Always mount the installation plate horizontally by aligning the marking-off line with the thread and using a level gauge.
- 2 Drill the piping plate hole with $\varnothing 70$ mm hole-core drill.
 - Put measuring tape at position as shown in the diagram above. The hole centre is obtained by measuring the distance namely 115 mm and 120 mm for left and right hole respectively.
 - Drill the piping plate hole at either the right or left and the hole should be slightly slanted to the outdoor side.

10.2.2 To Drill a Hole in the Wall and Install a Sleeve of Piping

- 1 Insert the piping sleeve to the hole.
- 2 Fix the busing to the sleeve.
- 3 Cut the sleeve until it extrudes about 15mm from the wall

Caution

When the wall is hollow, please be sure to use the sleeve for tube ass'y to prevent dangers caused by mice biting the connecting cable.

- 4 Finish by sealing the sleeve with putty or caulking compound at the final stage.

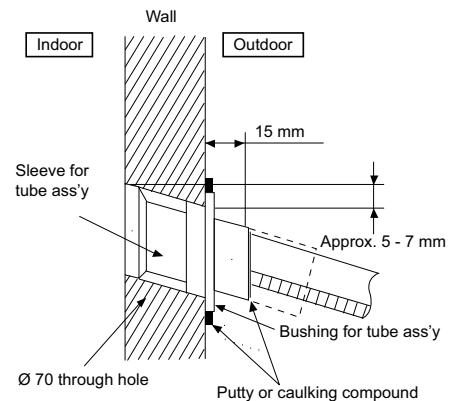

10.2.3 Indoor Unit Installation

1. FOR THE RIGHT REAR PIPING

Pull out the Indoor piping

Install the Indoor Unit

Secure the Indoor Unit

Insert the connecting cable

2. FOR THE RIGHT AND RIGHT BOTTOM PIPING

Pull out the Indoor piping

Install the Indoor Unit

Insert the connecting cable

Secure the Indoor Unit

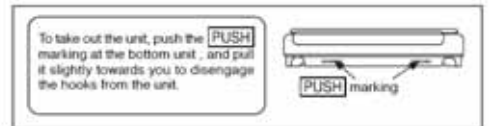
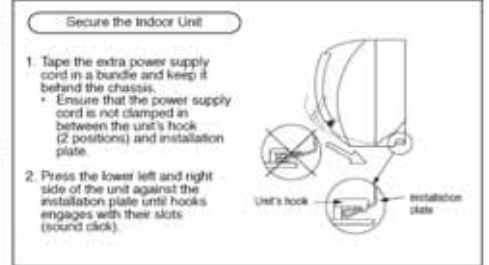
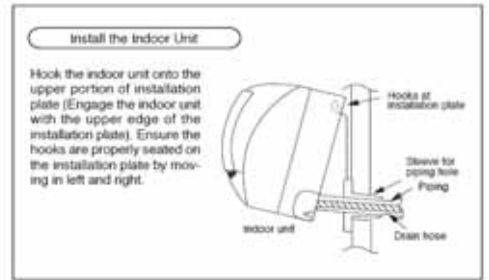
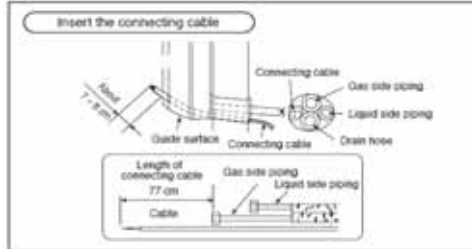
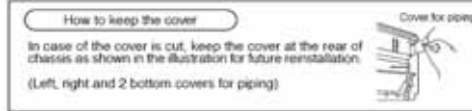
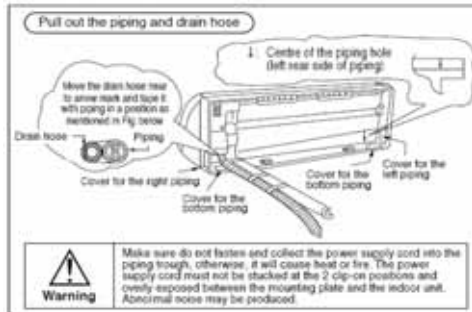

3. FOR THE EMBEDDED PIPING

Replace the drain hose

Bend the embedded piping

- Use a spring bender or equivalent to bend the piping so that the piping is not crushed.

Install the Indoor Unit

Cut and flare the embedded piping

- When determining the dimensions of the piping, slide the unit all the way to the left on the installation plate.
- Refer to the section "Cutting and flaring the piping".

Pull the connecting cable into Indoor Unit

- The inside and outside connecting cable can be connected without removing the front grille.

Connect the piping

- Please refer to "Connecting the piping" column in outdoor unit section. (Below steps are done after connecting the outdoor piping and gas-leakage confirmation.)

Insulate and finish the piping

- Please refer to "Insulation of piping connections" column as mentioned in Indoor/Outdoor Unit Installation.





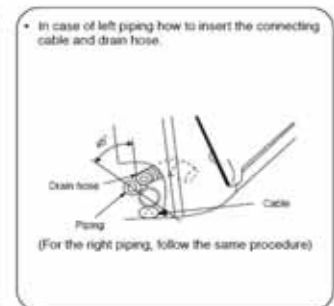
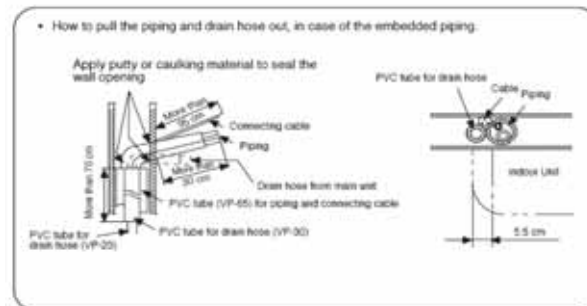
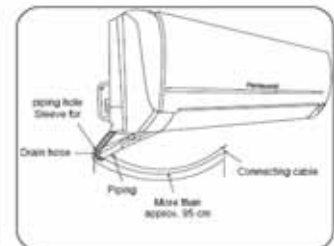
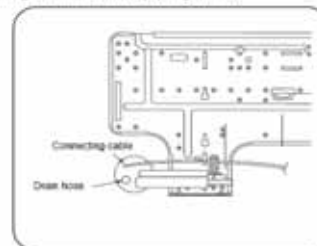
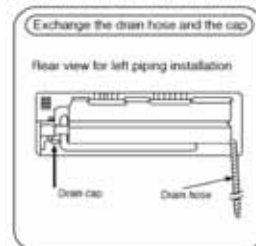

Secure the Indoor Unit

(This can be used for left rear piping & left bottom piping also.)



10.2.4 Connect the Cable to the Indoor Unit

- 1 The inside and outside connecting cable can be connected without removing the front grille.
- 2 Connecting cable between indoor unit and outdoor unit shall be approved polychloroprene sheathed 4x 1.5mm² flexible cords, type designation 245 IEC 57 or heavier cord.
 - ◆ Ensure the color of wires of outdoor unit and the terminal numbers are the same to the indoor's respectively.
 - ◆ Earth lead wire shall be longer than the other lead wires as shown in the figure for the electrical safety in case of the slipping out of the cord from the anchorage.

Terminals on the indoor unit	1(L)	2(N)	3	
Colour of wires				
Terminals on the outdoor unit	1(L)	2(N)	3	

- ◆ Secure the cable onto the board with the holder (clammer).

- 3 Wire stripping and connecting requirement.

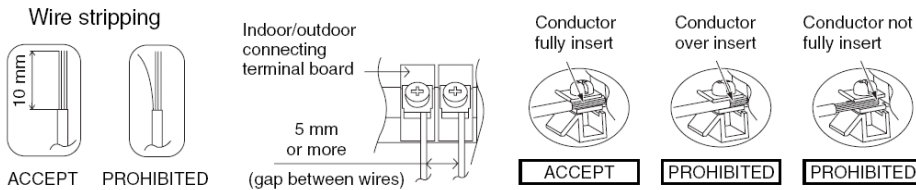
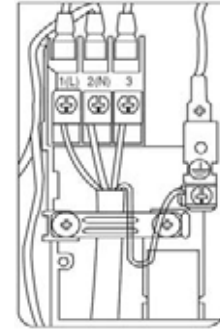

10.3 Outdoor Unit

10.3.1 Install the Outdoor Unit

- After selecting the best location, start installation according to indoor/outdoor unit installation diagram.
 - 1 Fix the unit on concrete or rigid frame firmly and horizontally by bolt nut (ø10 mm).
 - 2 When installing at roof, please consider strong wind and earthquake. Please fasten the installation stand firmly with bolt or nails.

A	B	C	D
570	104	13.5	320

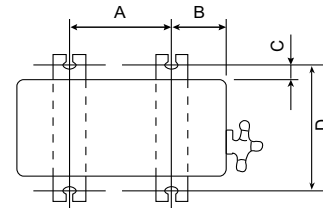

10.3.2 Connecting the Piping

10.3.2.1 Connecting the piping to indoor unit

Please make flare after inserting flare nut (locate at joint portion, of tube assembly) onto the copper pipe. (In case of using long piping)

Connect the piping

- Align the center of piping and sufficiently tighten the flare nut with fingers.
- Further tighten the flare nut with torque wrench in specified torque as stated in the table.

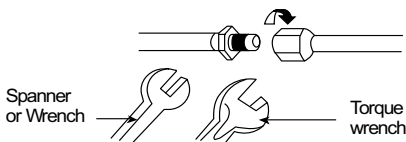

Model	Piping size (Torque)	
	Gas	Liquid
RE9JKE	3/8" (42N•m)	1/4" (18N•m)
RE12JKE	3/8" (42N•m)	1/4" (18N•m)
RE15JKE	1/2" (55N•m)	1/4" (18N•m)

Caution : Do not over tighten, over tightening cause gas leakage

Connecting the piping to outdoor unit

Decide piping length and then cut by using pipe cutter. Remove burrs from cut edge. Make flare after inserting the flare nut (locate at valve) onto the copper pipe. Align center of piping to valves and then tighten with torque wrench to the specified torque as stated in the table.

10.3.2.2 Cutting and flaring the piping

- 1 Please cut using pipe cutter and then remove the burrs.
- 2 Remove the burrs by using reamer. If burrs are not removed, gas leakage may be caused. Turn the piping end down to avoid the metal powder entering the pipe.
- 3 Please make flare after inserting the flare nut onto the copper pipes.

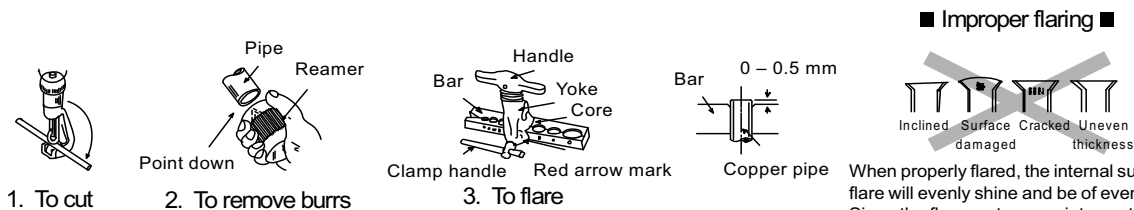

When properly flared, the internal surface of the flare will evenly shine and be of even thickness. Since the flare part comes into contact with the connections, carefully check the flare finish.

10.3.3 Evacuation of the equipment

When installing an air conditioner, be sure to evacuate the air inside the indoor unit and pipes in the following procedure.

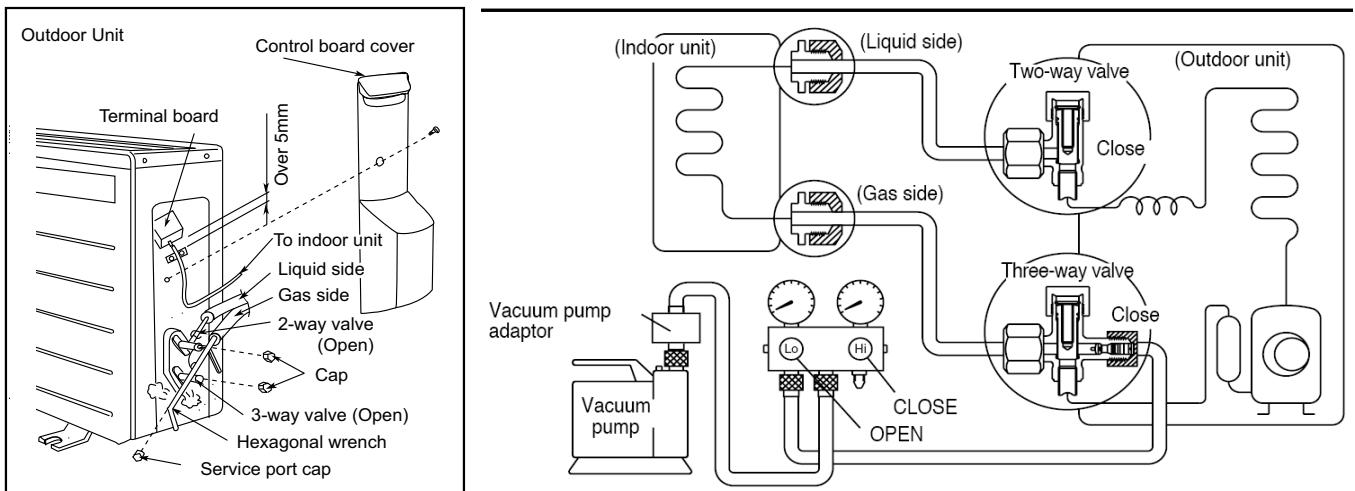

- 1 Connect a charging hose with a push pin to the low side of a charging set and the service port at the 3-way valve.
 - Be sure to connect the end of charging hose with the push pin to the service port.
 - The size of charging hose fitting should be 1/2 UNF, 20 threads.
- 2 Connect the center hose of the charging set to a vacuum pump with check valve, or vacuum pump and vacuum pump adaptor.
- 3 Turn on the power switch of the vacuum pump and make sure that the needle in the gauge moves from 0 cmHg (0 Mpa) to -76 cmHg (-0.1 Mpa). Then evacuate the air approximately ten minutes.
- 4 Close the Low side valve of the charging set and turn off the vacuum pump. Make sure that the needle in the gauge does not move after approximately five minutes.

Note: BE SURE TO FOLLOW THIS PROCEDURE IN ORDER TO AVOID REFRIGEANT GAS LEAKAG
- 5 Disconnect the charging horse from the vacuum pump and from the service port of the 3-way valve.
- 6 Tighten the service port caps of the 3-way valve at a torque of 18 N.m with a torque wrench.
- 7 Remove the valve caps of both of the 2-way valve and 3-way valve. Position both of the valves to "OPEN" using a hexagonal wrench (4mm).
- 8 Mount valve caps onto the 2-way and the 3-way valve.
 - Be sure to check for gas leakage.

CAUTION:

- If gauge needle does not move from 0 cmHg (0 MPa) to -76 cmHg (-0.1 MPa), in step 3 above take the following measure:
- If the leak stops when the piping connections are tightened further, continue working from step 3.
- If the leak does not stop when the connections are retightened, repair the location of leak.
- Do not release refrigerant during piping work for installation and reinstallation. Take care of the liquid refrigerant, it may cause frostbite.

10.3.4 Connect the cable to the Outdoor Unit

- 1 Remove the control board cover from the unit by loosening the screw.
- 2 Connecting cable between indoor unit and outdoor unit shall be approved polychloroprene sheathed 4x 1.5mm² flexible cord, type designation 245 IEC 57 or heavier cord.

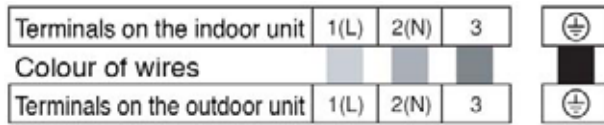

- 3 Secure the cable onto the control board with the holder (clammer).
- 4 Attach the control board cover back to the original position with the screw.
- 5 For wiring stripping and connection requirement, refer to instruction 10.2.4 of indoor unit.

10.3.5 Pipe Insulation

- 1 Please carry out insulation at pipe connection portion as mentioned in Indoor/Outdoor Unit Installation Diagram. Please wrap the insulated piping end to prevent water from going inside the piping.
- 2 If drain hose or connecting piping is in the room (where dew may form), please increase the insulation by using POLY-E-FOAM with thickness 6mm or above.

11. Service Mode

11.1 Auto OFF/ON Button

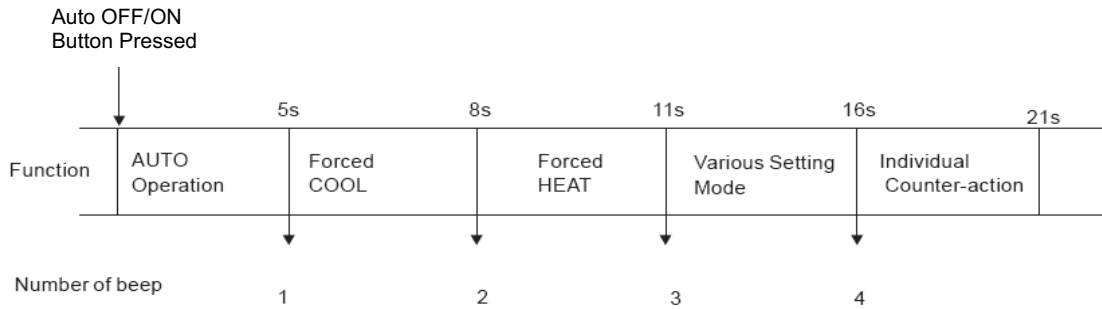

1. **AUTO OPERATION MODE**
Once the Auto OFF/ON button is slightly pressed, the unit will immediately operate in Auto operation. This operation can be used to operate air conditioner with limited function if remote control is misplaced or malfunction.
2. **TEST RUN OPERATION(FOR PUMP DOWN/ SERVICING PURPOSE)**
Press the button continuously for approximate 5 second and then release. A “beep” sound will be heard to identify the starting of TEST RUN OPERATION.
3. **HEATING OPERATION**
 - A) Within 5 minutes after TEST RUN operation starting, press the button again for more than 5 seconds until 2 “beep” sounds are heard, the unit will operate in heating mode.
 - B) Pressed the button continuously for approximate 8 second and then released. 2 “beep” sounds will be heard to identify the starting of HEATING operation.
4. **DIFFERENT CONTROLLING SETTING.**
Press the button continuously for approximate 11 until 3 “beep” sounds are heard and together with the signal from remote controller, the unit can be changed to different controlling setting.
For transmission code selection method, please refer to “Select Remote Control Transmission Code”
5. **INDIVIDUAL COUNTER-ACTION**
When the switch is continuously pressed between 16 to 21 seconds, either H14 error detection selection mode or remote controller’s signal receiving sound can be cancelled or turned on.

11.2 Select Remote Control Transmission Code

- ✧ There are 4 types of remote control transmission code could be selected and stored in EEPROM of indoor PCB. The indoor unit will only operate when received signal with same transmission code from remote control. This could prevent signal interference when there are 2 or more indoor units installed near by together.
- ✧ To Change the code of remote controller, following table 1 to join or cut jumper wire on the remote controller and setting with "Forced operation button". Four codes (A, B, C, D) can be selected. Taking code "B" for example, the process below should be follow.
 1. Press the "Auto OFF/ON" button on the indoor unit for approximate 11 seconds until 3 "Beep's signal receiving sounds are heard.
 2. Within 5 minutes, gently press the "RESET" button on the remote control towards the indoor unit. One "Beep" sound is heard.
 3. Within 60 seconds, press any button on the remote control, the frequency of which was set as "B". Setting is completed after a "Beep" sound is heard. The corresponding signal sent by remote control "B" will be received by this indoor unit

Table 1

Remote control	J02	J03
A(STANDARD)	SHORT	OPEN
B	OPEN	OPEN
C	SHORT	SHORT
D	OPEN	SHORT

11.3 Operate and Display of Remote Control

11.3.1 Original setting



11.3.2 Mode selecting button

AUTO, HEAT, COOL, DRY can be selected by pressing "MODE" button. Initial display of LCD is as follow

MODE	SET TEMP	FAN SPEED	AIR SWING
AUTO	25°C	AUTO	AUTO
HEAT	22°C	AUTO	AUTO
COOL	27°C	AUTO	AUTO
DRY	25°C	AUTO	AUTO

*Keeping the button depressed continuously, the operation mode will change in the following order in turn
 AUTO—HEAT—COOL—DRY--AUTO

11.3.3 Temperature adjusting button

Temperature adjusting range is between 16 °C~30 °C

11.3.4 Fan speed button

There are 5 speed levels can be selected. The display on the remote controller changes as follows by pressing the AIR SWING button.



11.3.5 AIR SWING button

To adjust vertical airflow directions by pressing AIR SWING button (5 options)

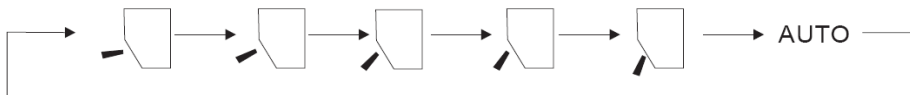

11.3.6 QUIET/POWERFULL button

Press this button to switch among QUIET operation, POWERFUL operation and normal operation.

Start Quiet operation: Press this button until "QUIET" displaying on remote control display to identify Quiet mode operating.

Start POWERFUL operation: Press this button until POWERFUL displays on remote control display to identify Quiet mode operating.

Switch Quiet /Powerful operation to normal operation: Press this button until "QUIET" and "POWERFUL" on remote control display disappear, which identifies the unit returns to normal operation.

Note: QUIET and POWERFUL operation can not be active simultaneously.

11.3.7 Timer setting button

There are 4 types of timer setting by pressing Timer setting button: ON-TIMER, OFF-TIMER, ON-OFF TIMER, OFF-ON TIMER.

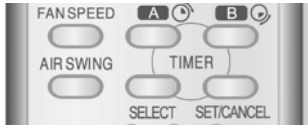

1) SELECT button

✧ When the air conditioner is ON, OFF-TIMER or OFF-ON TIMER can be selected by pressing SELECT button.

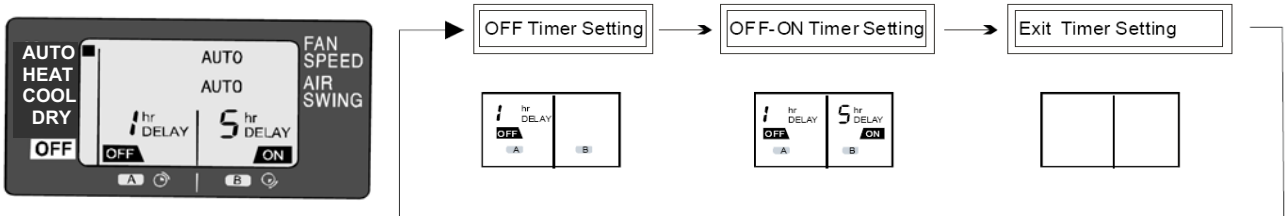

✧ When the air conditioner is turned off, ON-TIMER or ON-OFF-TIMER can be selected.

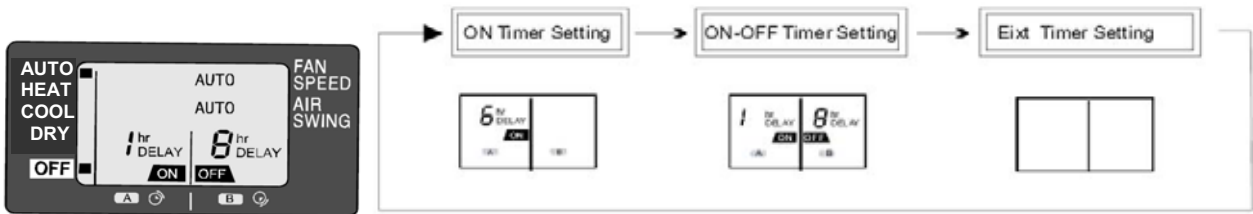

2) Button A and B

Pressing button A can change the time for ON-TIMER and OFF-TIMER, off time for OFF-ON Timer, on time for ON-OFF TIMER; Pressing button B can change the on time for OFF-ON Timer and off time for ON-OFF Timer setting.

3) SET/CANCEL button.

Pressing the button to set or cancel the set timer during the timer setting or activate the previous timer setting. After the timer setting is determined, "ON" or "OFF" will stop flashing. If the timer setting is cancelled, "ON" or "OFF" will disappear on the remote control display.

NOTE:

- ✧ OFF Timer and OFF- ON Timer can only be set during the operation;
- ✧ Timer setting can operate only once.
- ✧ If the OFF/ON button on the remote control or the AUTO Switch on the indoor unit is pressed, the timer setting will be cancelled.
- ✧ If Auto Restart Control occurs, timer setting will be cancelled.
- ✧ During the operation, if the ON Timer or ON-OFF Timer is set, the operation will be stopped.

11.3.8 About Cursor Key Which Points To "OFF" On Remote Control

When the ON/OFF button on the remote control is pressed, the cursor key which points to "OFF" will appear or disappear to indicate the ON/OFF status of the air conditioner.



For some reason (Ex. The signal of the remote control does not reach the signal receiver of the indoor unit.), the display of the remote control will not correspond with the actual ON/OFF status of the indoor unit:

1. The air conditioner is running but the cursor key which points to "OFF" appears. The air conditioner can be stopped with any button (Except for "ON/OFF", "TIMER SET", "TIMER ON") pressed.
2. The air conditioner is on standby, but the cursor key which points to "OFF" disappears. The air conditioner can be started with any button (Except for "ON/OFF", "TIMER SET", "TIMER OFF") pressed.

12. Operation Control

12.1 Basic Function

12.1.1 Internal Setting Temperature

Once the operation starts, remote control setting temperature will be taken as base value for temperature shifting processes. These shifting processes are depending on the air conditioner settings and the operation environment. The final shifted value will be used as internal setting temperature and it is updated continuously whenever the electrical power is supplied to the unit.

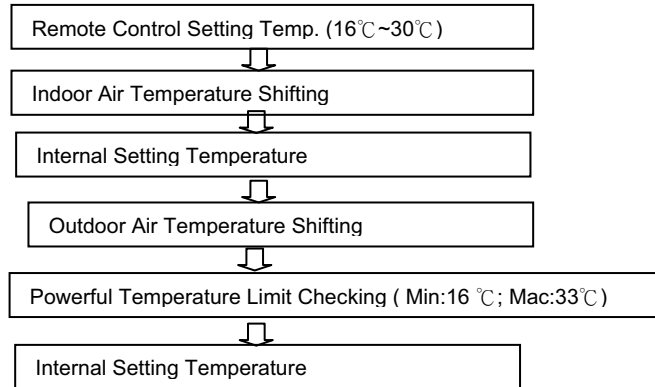

12.1.2 Cooling Operation

12.1.2.1 Thermostat control

- Compressor is OFF when Intake Air Temperature - Internal Setting Temperature < -1.5°C
- Compressor is ON after waiting for 3 minutes, if the Intake Air Temperature - Internal Setting Temperature > Compressor OFF point.

12.1.3 Soft Dry Operation

12.1.3.1 Thermostat control (The same as Cooling mode)

12.1.4 Heating operation

12.1.4.1 Thermostat control

- Compressor is OFF when Intake Air Temperature - Internal Setting Temperature > +2.0°C
- Compressor is ON after waiting for 3 minutes, if the Intake Air Temperature - Internal Setting Temperature < Compressor OFF point.

12.1.5 Automatic Operation

1. Once AUTO mode is selected, operation mode is determined by set temperature of remote control, indoor intake temperature and outdoor temperature.
2. During operating mode judgment, indoor fan runs at min Lo- fan speed and outdoor fan runs in the purpose of detecting the intake air temperature and outdoor air temperature (for 30 seconds)

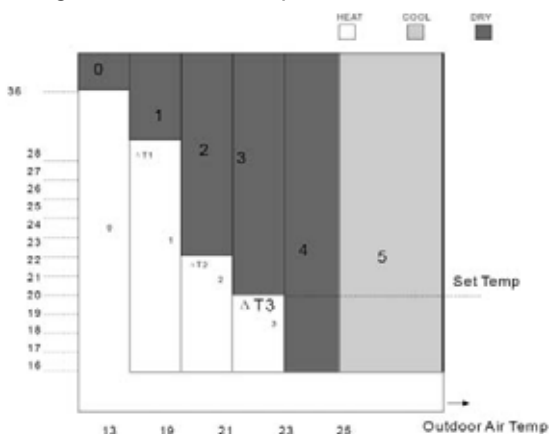

$$\text{Set Temp} = \text{Remote Set Temp} + \Delta T$$

Set Temp on Remote Control	$\Delta T1$	$\Delta T2$	$\Delta T3$
16, 17, 18	+10	-3	-5
19, 20, 21, 22	+8	-3	-7
23, 24, 25, 26	+7	-3	-7
27, 28, 29, 30	+6	-3	-8

If the operation mode changed, $\Delta T1$, $\Delta T2$, $\Delta T3$ will change as follow:
 Cooling /Soft Dry → Heating Operation: -2°C
 Heating → Cooling /Soft Dry Operation: +2°C

12.2 Indoor Fan Motor Operation

Basic Rotation Speed

i. Manual Fan speed

Fan motor's number of rotation is determined according to remote control setting.

Model	Remote control	O	O	O	O	O	QUIET
	Tab	Hi	Me+	Me	Me-	Lo	QLo
CS-RE9JKE	COOLING(rpm)	1200	1040	940	840	740	640
	HEATING(rpm)	1200	1080	980	880	780	730
CS-RE12JKE	COOLING(rpm)	1210	1110	1020	930	840	640
	HEATING(rpm)	1260	1170	1100	1030	960	820
CS-RE15JKE	COOLING(rpm)	1240	1130	1050	970	890	840
	HEATING(rpm)	1300	1210	1130	1050	970	820

ii. Auto Fan Speed (Cooling, Soft Dry Mode)

According to room temperature and setting temperature, indoor fan speed is determined automatically. The indoor fan will operate according to pattern below.

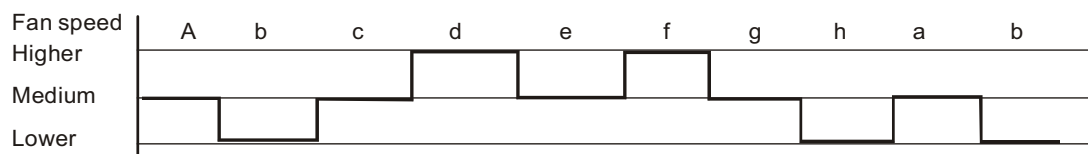

B. Feedback control

- Immediately after the fan motor started, feedback control is performed once every second.
- During fan motor on, if fan motor feedback 2550 rpm or < 50 rpm continue for 10 seconds, then fan motor error counter increases, fan motor then stops and restarts. If the fan motor counter becomes 7 times, then H19 - fan motor error is detected. Operation stops and cannot on back.

12.3 Outdoor Fan Motor Operation

Outdoor fan motor is operated with one fan speed only. It starts when compressor starts operation and it stops 30 seconds after compressor stops operation.

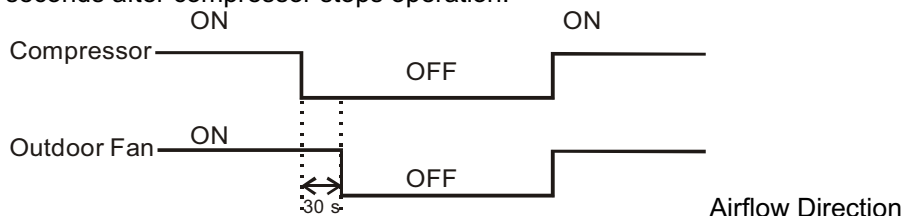

12.3.1 Vertical Airflow

Operating Mode		1	2	3	4	5	
Cooling	Manual	15°	25°	35°	45°	55°	
	Auto	Normal	15° ~ 55°				
		Powerful	40° (Beginning of POWERFUL mode) , 18°				
Soft dry	Manual	15°	25°	35°	45°	55°	
	Auto	Normal	16°				
		Powerful	16°				
Heating	Manual	17°	30°	43°	56°	68°	
	Auto	Normal	16° , 17° , 48°				
		Powerful	16° , 17° , 42° , 47°				

- Automatic vertical airflow direction can be set using remote control; the vane swings up and down within the angles as stated above. For heating mode operation, the angle of the vane depends on the indoor heat exchanger temperature. When the air conditioner is stopped using remote control, the vane will shift to close position.
 - Manual vertical airflow direction can be set using remote control. The angles of the vane are as stated above. When the air conditioner is stopped using remote control, the vane will shift to close position.
- * Above angle data is for reference only.

12.3.2 Horizontal Airflow

The horizontal airflow direction louvers can be adjusted manually by hand.

12.3.3 Quiet operation

- To provide quiet operation comparing to normal operation. The Quiet operation can be active or stop by pressing QUIET/POWERFUL button on remote control.
- Once Quiet mode is active, the unit will continuously operate in QUIET Mode until cancel the mode by pressing QUIET/POWERFUL button on remote control.

12.3.4 Powerful operation

- To cooling or heating the room faster comparing to normal operation. The POWERFUL operation can be active or stop by pressing QUIET/POWERFUL button on remote control.
- When powerful operation is active, the unit will continuously operate in POWERFUL mode until cancel the mode by pressing QUIET/POWERFUL button on remote control. Operation details are as the fig. below.

- For cooling, soft Dry mode

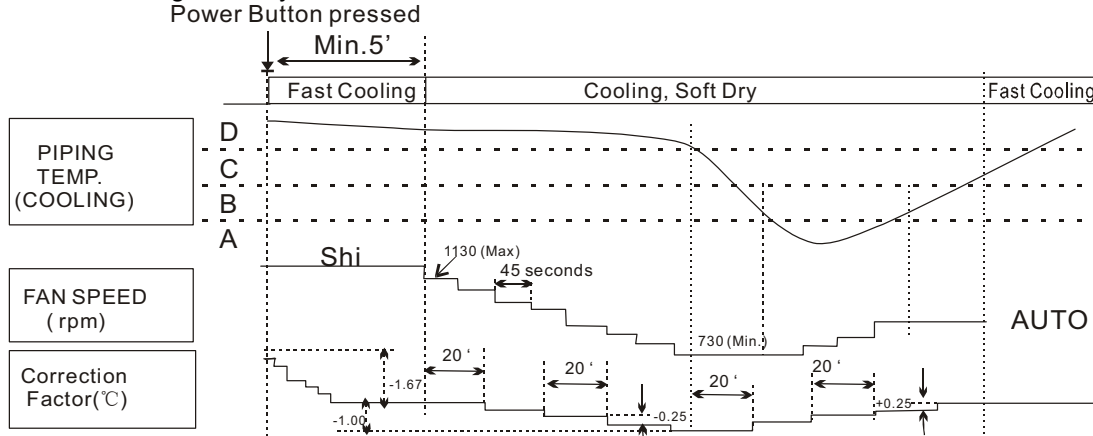

- For Heating mode:

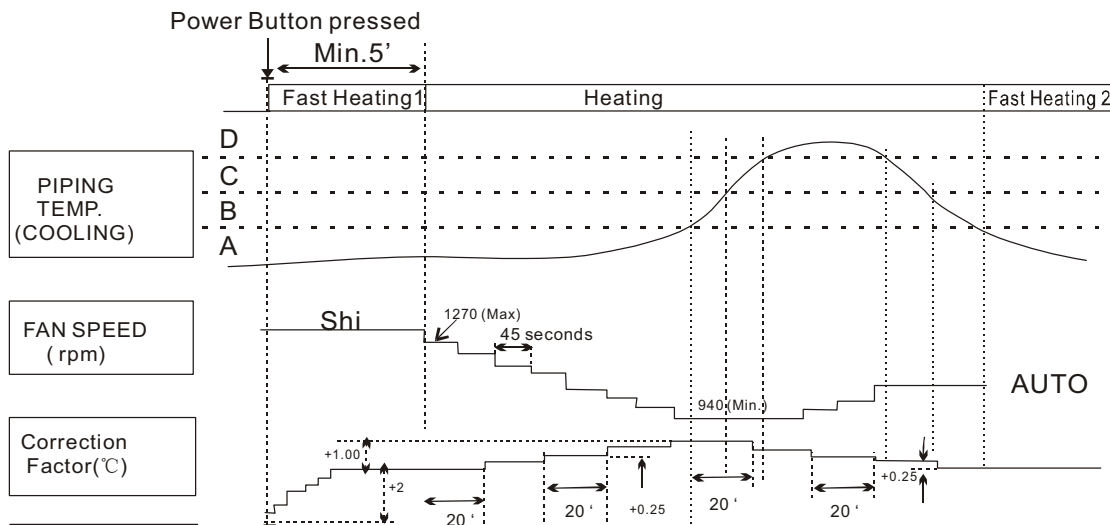

Note: The value of A, B, C, D will change according to the indoor temperature.

12.3.5 Automatic Restart Control

When the power supply is cut off during the operation of air conditioner, the compressor will re-operate within three to four minutes after power supply resumes.

12.3.6 Indication Panel

LED	POWER	TIMER
Color	Green	Orange
Light ON	Operation ON	Timer setting ON
Light OFF	Operation OFF	Timer setting OFF

Note:

- If POWER LED blinks, the possible operation of the unit is operation mode judgment, or ON timer sampling.
- If Timer LED blinks, there is an abnormal operation occurs.

12.3.7 Timer control

Delay ON Timer can be set using remote controller, the unit with timer set will start operate earlier than the setting time. This is to provide a comfortable environment when reaching the set On time. Seventy minutes before the set time for ON Timer or ON-OFF Timer setting, indoor (at fan speed of Lo-) and outdoor fan motor start operate for 30 seconds to determine the indoor intake air temperature and outdoor air temperature in order to judge the operation mode. From the above judgment, the decided operation will start operate earlier than the set time as shown below.

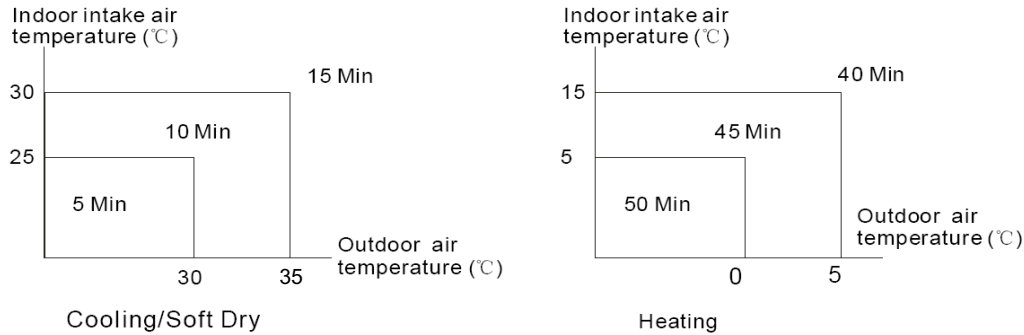

Timer Signal Receiving sound During Operation.

	Operation	Sound	Timer LED	Timer Setting
ON Timer Set	OFF	Beep-	ON	Valid
OFF Timer Set	ON	Beep	ON	Valid
ON-OFF Timer Set	OFF	Beep-	ON	Valid
OFF-ON Timer Set	ON	Beep	ON	Valid

Timer Signal Receiving Sound When the Air Conditioner Stops.

	Operation	Sound	Timer LED	Timer Setting
ON Timer Set	OFF	Beep	ON	Valid
OFF Timer Set	OFF	None	OFF	Invalid
ON-OFF Timer Set	OFF	Beep	ON	Valid
OFF-ON Timer Set	OFF	None	OFF	Invalid

13. Protection control

13.1 Protection Control For All Operations

13.1.1 Time Delay Safety Control

- The Compressor will not turn on within 3 minutes from the moment operation stops, although the unit is turned on again by pressing OFF/ON button at remote control within this period.
- This control is not applicable if the power supply is cut off and on again.
- This phenomenon is to balance the pressure inside the refrigerant cycle.

13.1.2 30 Seconds Forced Control

- Once the air conditioner is turned on, the compressor will not stop within 30 seconds in a normal operation although the intake air temperature has reached the thermo-off temperature. However, force stop by pressing the OFF/ON button at the remote control is permitted or the Auto OFF/ON button at indoor unit.
- The reason for the compressor to force operation for minimum 30 seconds is to allow the refrigerant oil run in a full cycle and return back to the outdoor unit.

13.1.3 Total running current control

1. If the outdoor unit total running current is detected exceeding $I_1(A)$, the frequency instructed for compressor operation will be decreased.
2. If the running current does not exceed $I_1(A)$ for 5 seconds, the frequency instructed will be increased.

Operation mode	RE9JKE	RE12JKE	RE15JKE
	$I_1(A)$	$I_1(A)$	$I_1(A)$
Cooling/ Soft Dry /Fan A*	5.03	6.35	8.98
Cooling/ Soft Dry /Fan B	4.89	6.22	8.00
Heating	4.75	6.22	9.31

*The first 30 minutes of cooling operation, A will be applied.

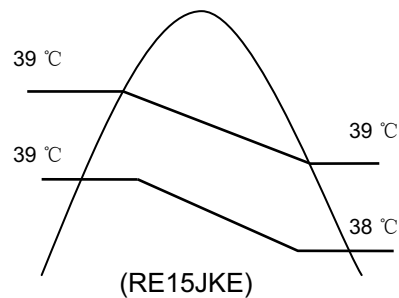
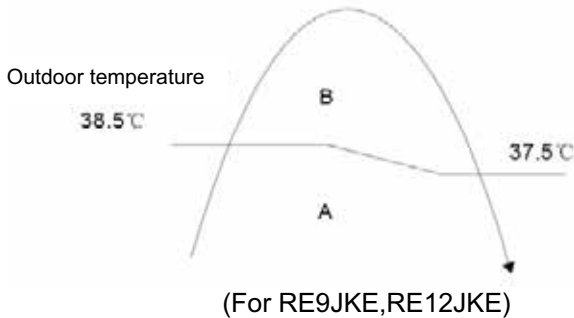

13.1.4 IPM (Power transistor) Protection Control.

1. DC Peak Current Control
 - When electric current to IPM exceeds set value of DC17.3 1A, the compressor will stop. It will restart after three minutes.
 - If the set value is exceeded again within 30 seconds, the operation will restart after one minute.
 - If this condition repeats continuously for seven times, all indoor and outdoor relays will be cut off.
 - Error code [F99] will be displayed.
2. Overheating protection control

When the IPM temperature rises to 112 °C , compressor will stop immediately.
Compressor restarts after three minutes if the temperature decreases to 97°C

13.1.5 Compressor Overheating Prevention Control

Instructed frequency for compressor operation will be regulated compressor discharge temperature. The change of frequency is as below.

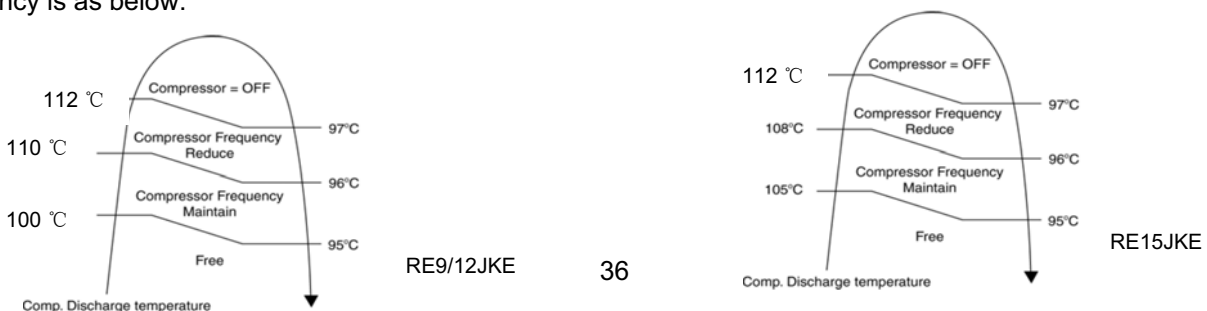

13.1.6 Low pressure Prevention control (Gas Leakage Detection)

1. When the conditions listed in the table occur, the compressor stops and restarts after three minutes.
2. If this continuously occurs for twice within 20 minutes, all indoor and outdoor relays will be cut off.
3. This control is not applicable for deice operation.

Comp Frequency	45 Hz or above	64 Hz or above	58 Hz or above	73 Hz or above
Total Outdoor Current	1b≤1<3	1b≤1<1.6	1b≤1<1.3	1b≤1<1.6
Indoor Piping Temp	20 °C or above	25 °C or less	20 °C or above	25 °C or less
Operation Mode	Cool/Dry	Heat	Cool/Dry	Heat
Model	RE9JKE		RE12JKE	

13.1.7 Low Operation Frequency Protection Control

If all following conditions exists, the compressor will run with the frequency of 40 Hz (RE9JKE,RE12JKE) or 30Hz (RE15JKE)

Models	RE9JKE, RE12JKE		≥<<>RE15JKE	
Intake Air Temp.	≥30 °C or <15 °C	-----	≥30 °C or <14 °C	≥28 °C or <14 °C
Outdoor Temp.	≥38 °C or <16 °C	≥24 °C or <4 °C	≥38 °C or <13 °C	≥24 °C or <4 °C
Indoor Piping Temp.	<30 °C	≥0 °C	<30 °C	≥0 °C
Operation Mode	Cool / Dry	Heat	Cool/ Dry	Heat

13.1.8 Compressor Tank Temperature Rise Protection Control

a. Control start conditions

- For 5 minutes, the compressor continuously operates and outdoor total current is between 0.65A and 1.65A.
- During Cooling and Soft Dry operations:
 - Indoor suction temperature - indoor piping temperature is below 4°C.
 - Indoor temperature and outdoor temperature is 30±5°C.
 - Remote Control setting 16°C and Hi Fan Speed.
- During Heating operations:
 - Indoor piping temperature - indoor suction is under 5°C.
 - Indoor temperature and outdoor temperature is 20 ± 2°C.
 - Remote control setting 30°C and Hi Fan Speed.

b. Control contents

- Compressor stops (and restart after 3 minutes)
- If the conditions above happen 2 times within 20 minutes, the unit will:
 - Stop operation
 - Timer LED blinks and “F91” indicated

13.2 Protection Control For Cooling and Soft Dry Operation

13.2.1 Outdoor Air Temperature Control

- The compressor operating frequency is regulated in accordance to the outdoor air temperature as shown in the diagram below.
- This control will begin 1 minute after the compressor starts.
- Compressor frequency will adjust base on outdoor air temperature.

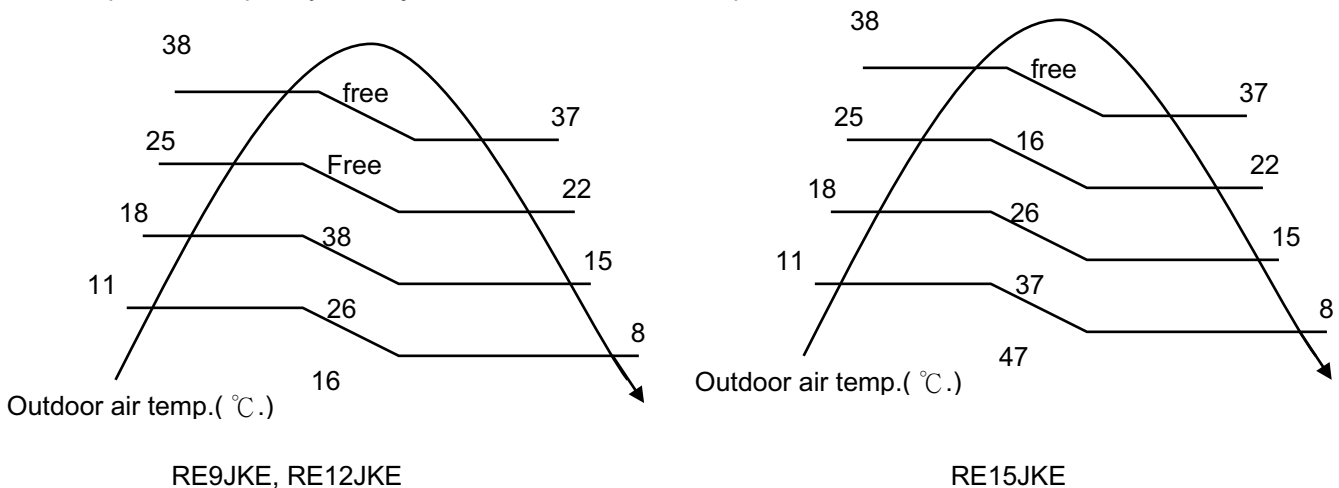

13.2.2 Freeze Prevention Control

1. Frequency of the compressor

For prevention of freezing of the indoor evaporator, the frequency of the compressor will be changed according to the indoor piping temperature.

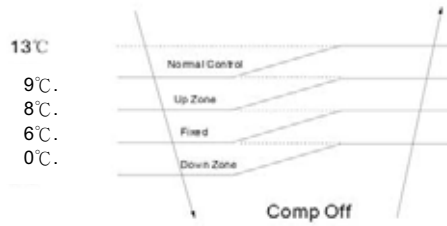

2. Indoor Fan Control

Indoor fan speed changes according to the indoor piping temperature.

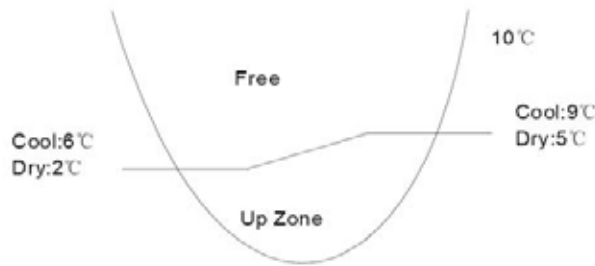

13.2.3 Dew Prevention Control

- To prevent dew formation at indoor unit discharge area.
- This control starts if all conditions continue for 20 minutes:
 - Operated with Cooling or Soft Dry Mode.
 - Indoor intake temperature is between 25°C and 29°C.
 - Outdoor air temperature is less than 30°C.
- This control stopped then receive air swing change signal from Remote Control.

13.2.4 Overload Protection For Cooling Operation

The frequency for the compressor will change according to the outdoor piping temperature.

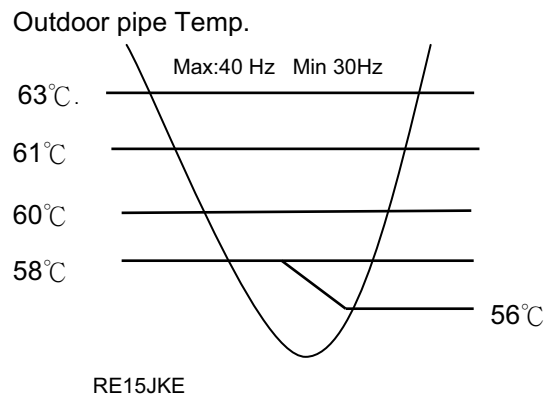
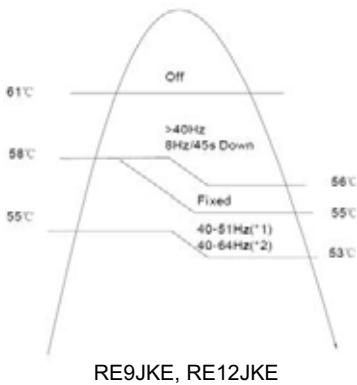

13.3 Indoor Piping Air Temperature Control (Heating)

13.3.1 Indoor Fan Control

1. Indoor fan is controlled by the indoor piping temperature.

- Manual Fan Speed

Piping Temperature(°C)

K0	K1	K2	K3	K4	K5	K6	K7	K8	K9	K10	K11
16	19	24	32	32	36	36	39	54	54	57	60

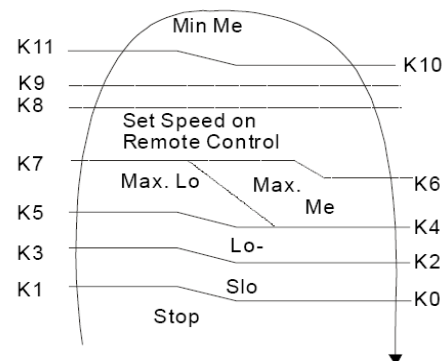

● Auto Fan Speed

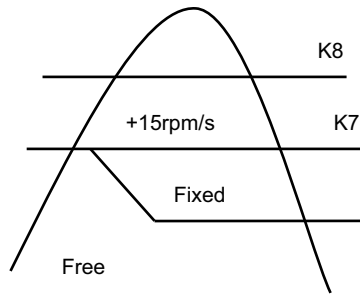

2. During heating operation, the indoor fan will run at the following speed when the compressor stops.

	1	2	3	4	5	6	7	8
Comp.	ON		OFF					
Fan speed (rpm)	Control by piping temp.		460					

3. Hot Start

When the heating operation starts, the indoor fan stops and the compressor run with the frequency of 117Hz.

This is to prevent the cold airflow from blowing.

If the piping temperature rises to 19 °C, and the indoor fan speed and airflow direction varies with the indoor piping temperature, the hot start control is completed.

13.3.2 Overload Protection Control

The frequency for the compressor is determined by indoor piping temperature.

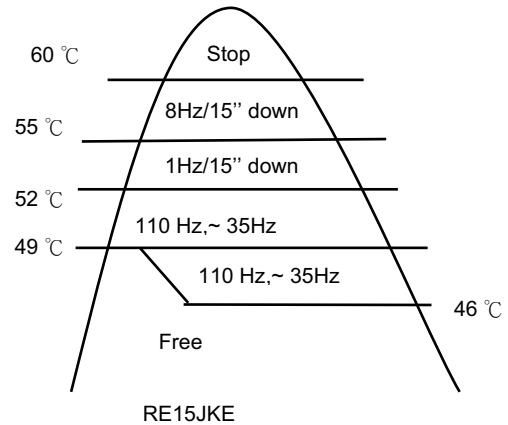
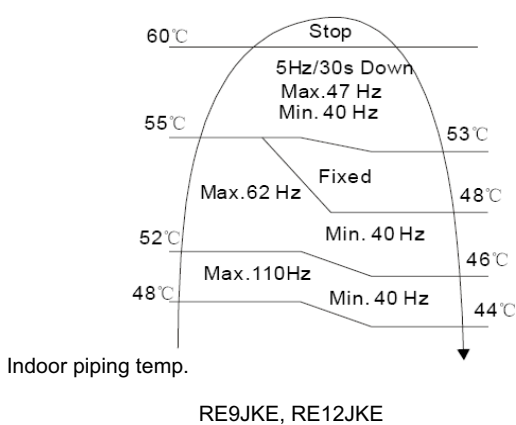

14. Troubleshooting Guide

14.1 Refrigeration cycle system

In order to diagnose malfunctions, make sure that there are no electrical problems before inspecting the refrigeration cycle. Such problems include insufficient insulation, problem with the power source, malfunction of a compressor and a fan. The normal outlet air temperature and pressure of the refrigeration cycle depends on various conditions, the standard values for them are shown in the table on the right.

Normal Pressure and Outlet Air Temperature (Standard)

	Gas Pressure Mpa (kg/cm ² G)	Outlet air Temperature (°C)
Cooling Mode	0.9~1.2 (9~12)	12~16
Heating Mode	2.3 ~2.9 (23~29)	36~45

Condition: Indoor fan speed = High
 Outdoor temperature = 35°C at cooling mode and 7°C at heating mode.
 Compressor operates at rated frequency

14.1.1

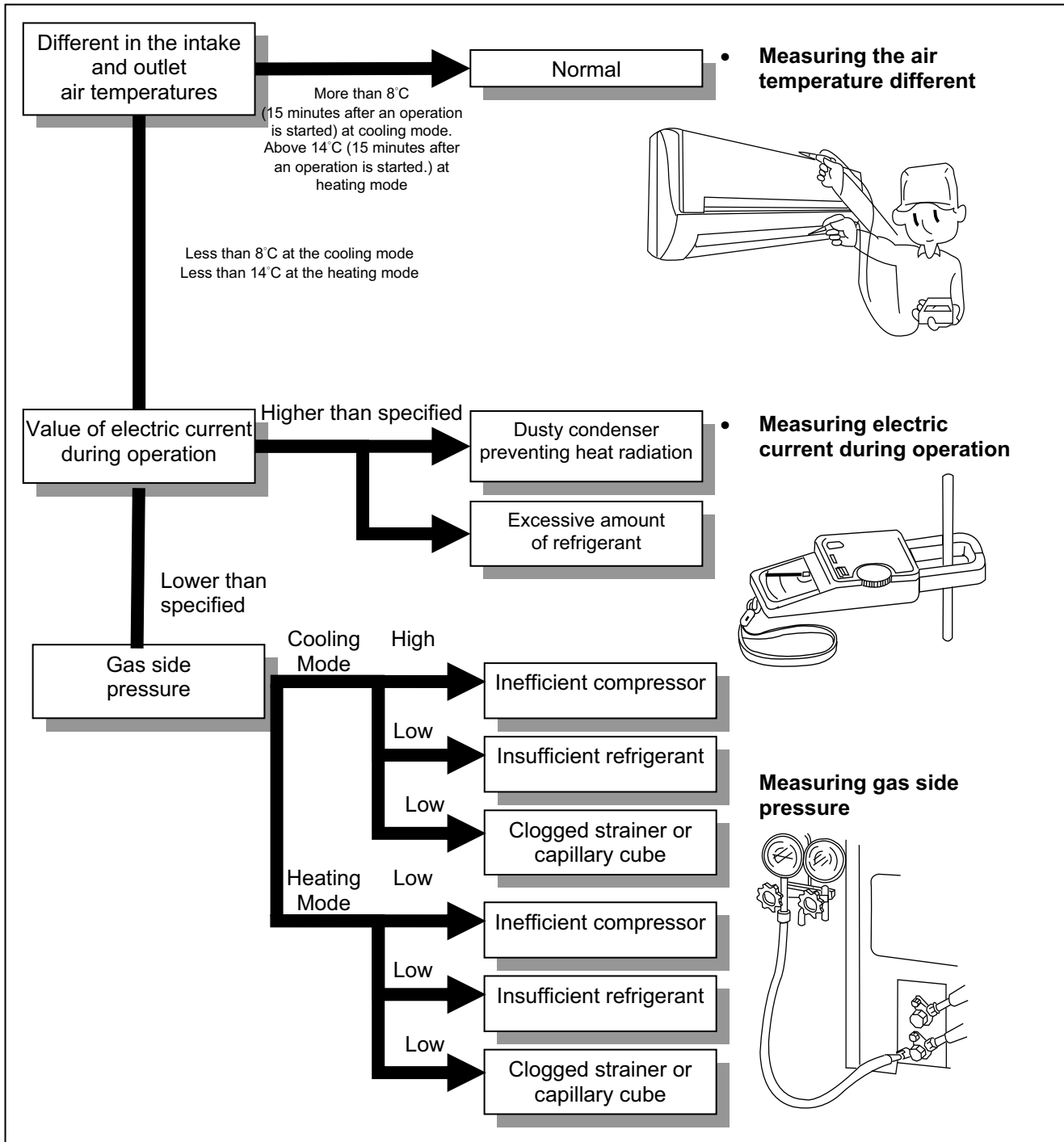

14.1.2 Relationship between the condition of the air conditioner and pressure and electric current

Condition of the air conditioner	Cooling Mode			Heating Mode		
	Low Pressure	High Pressure	Electric current during operation	Low Pressure	High Pressure	Electric current during operation
Insufficient refrigerant (gas leakage)	↘	↘	↘	↘	↘	↘
Clogged capillary tube or strainer	↘	↘	↘	↗	↗	↗
Short circuit in the indoor unit	↘	↘	↘	↗	↗	↗
Heat radiation deficiency of the outdoor unit	↗	↗	↗	↘	↘	↘
Inefficient compression	↗	↘	↘	↗	↘	↘

• Carry out the measurement of pressure, electric current, and temperature fifteen minutes after an operation is started.

14.2 Breakdown Self Diagnosis Function

14.2.1 About Self Diagnosis

When the air-conditioner is stopped due to malfunction detected by itself, the operation can be restarted using AUTO Switch on the indoor unit. In forced operation, the frequency for compressor and fan speed can not be changed and the signal receiving sound is different.

Normal Operation ON: "pep"

Forced Operation ON: "pep", "pep", "pep", "pep"

Stop: "pep"

Note: Refer to the Diagnosis Code Table for the malfunction when forced operation is not available.

14.2.2 Display of Error Code

1. Keeping the CHECK button on the remote controller depressed for 5 seconds, error code ranging from H11 to H99 can be displayed on the remote controller.
2. The error code is changed and diagnosis signal is transmitted to the indoor unit by pressing the Temp Up button on the remote control.
3. When the malfunction of the air-conditioner matches the error code on the remote control, four beeps can be heard from the indoor unit and the operation indicator will light up.
4. Keep the CHECK button depressed continuously for 5 seconds to cancel the diagnosis function.

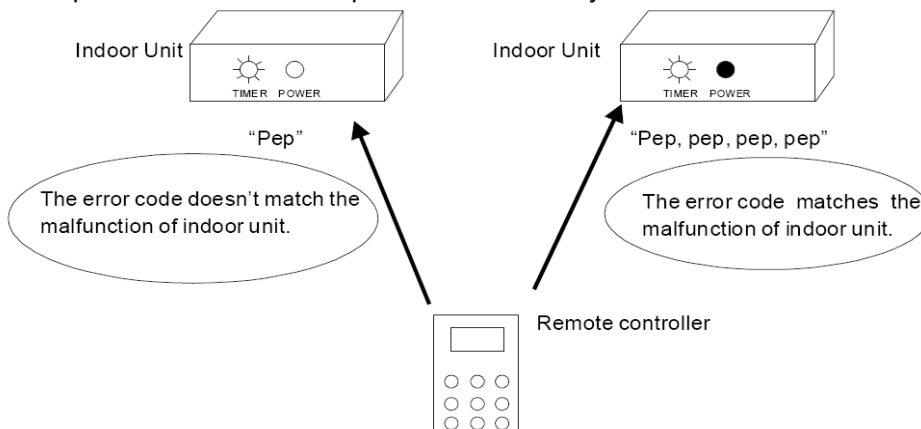

14.2.3 Error Codes Table

Code	Abnormality/Protection	Judgment	Check	Emergency Operation
H00	Normal			
H11	Indoor/Outdoor abnormal communication	>1minute after starting operation	Connecting cable, Indoor /outdoor PCB	○
H14	Indoor intake air temp sensor abnormality	-	Intake air temperature sensor(defected or disconnected)	X
H15	Outdoor compressor temperature sensor abnormality	Continue for 5 sec.	Compressor temperature sensor(defected or disconnected)	X
H16	Outdoor Current Transformer open circuit	-	Outdoor PCB, IPM module	X
H19	Indoor fan motor mechanism lock	-	Indoor PCB, fan motor	X
H23	Indoor heat exchanger temperature A sensor abnormality	Continue for 5 sec	Heat exchanger temperature sensor (defected or disconnected)	○
H25	Air filter abnormality	-		○
H27	Outdoor air temperature sensor abnormality	Continue for 5 sec	Outdoor temperature sensor(defected or disconnected)	○
H28	Outdoor heat exchanger temperature sensor abnormality	Continue for 5 sec.	Outdoor heat exchanger sensor (defected or disconnected)	○
H30	Discharge temperature sensor abnormality	Continue for 5 sec.	Discharge temperature sensor (defected or disconnected)	○
H33	Incorrect connection of Indoor/Outdoor cable	-	Indoor/outdoor supply voltage	X
H97	Outdoor fan motor lock	Twice within 30 minutes	Outdoor fan motor	X
H98	Indoor high pressure protection	-	Air filter dirty Air circulation short circuit	-
H99	Indoor heat exchanger anti-freezing protection	Indoor heat exchanger freezing	Insufficient refrigerant Air filter dirty	-
F11	Cooling/heating cycle changeover abnormality	4 times occurrence within 30 minutes	4-way valve V-coil	X
F16	Cooling/Dry cycle changeover abnormality	4 times occurrence within 30 minutes	Indoor PCB	X
F90	PFC control	4 times occurrence within 20 minutes	Voltage at PFC	X
F91	Refrigeration cycle abnormality	2 times occurrence within 20 minutes	No refrigerant (3-way valve is closed)	X
F93	Compressor abnormality	4 times occurrence within 20 minutes	Compressor	X
F95	Cool high pressure protection	4 times occurrence within 20 minutes	Outdoor refrigeration cycle	X
F96	IPM overheating protection	-	Excessive refrigerant Improper heat radiation IPM	X
F97	Outdoor compressor overheating protection	4 times occurrence within 20 minutes	Insufficient refrigerant Compressor	X
F98	Total running current protection	3 times occurrence within 20 minutes	Excess refrigerant Improper radiation	X
F99	Outdoor Peak Current Protection Control	4 times occurrence continuously within 30 minutes	Outdoor PCB IPM Compressor	X

15. Disassembly and Assembly Instructions



High Voltage is generated in the electrical parts area by the capacitor. Ensure that the capacitor has discharged sufficiently before proceeding with repair work. Failure to heed this caution may result in electric shocks.

Removal Procedure for Intake Grille

1. Open the intake grille and pull it to the horizontal position.

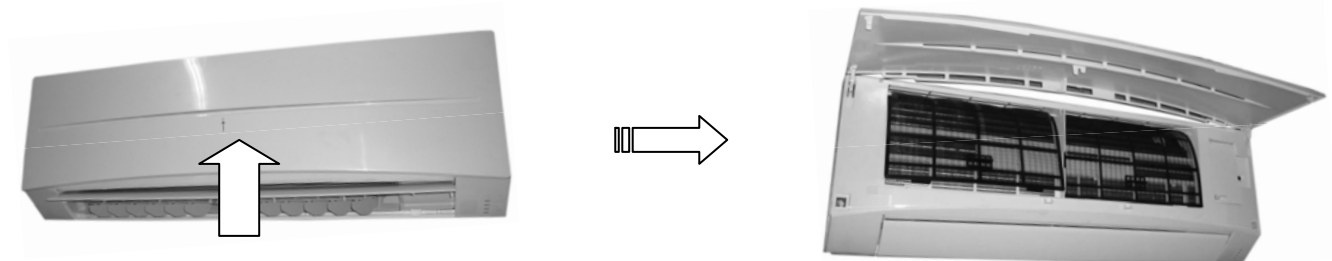

2. Pull up the intake grille until it falls off.

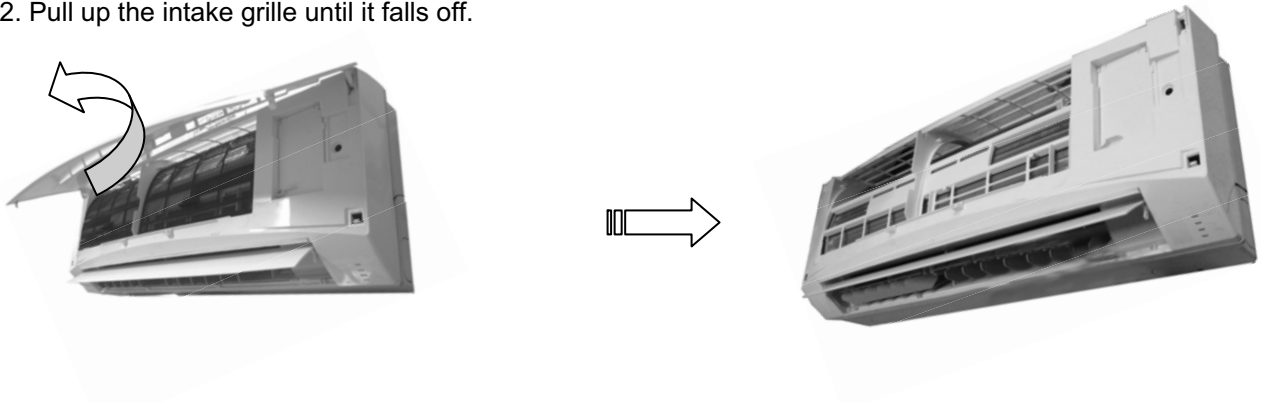

Removal Procedure for Front Grille

1. Remove the two caps at the discharge port (right and left) and then release the two screws on both sides.

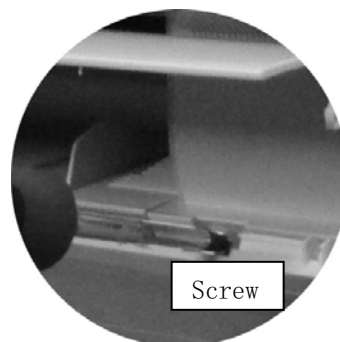
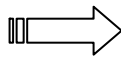
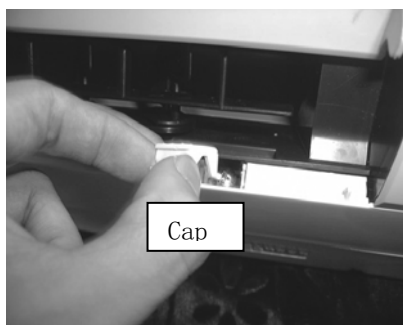

2. Pull out the front grille from the unit body.

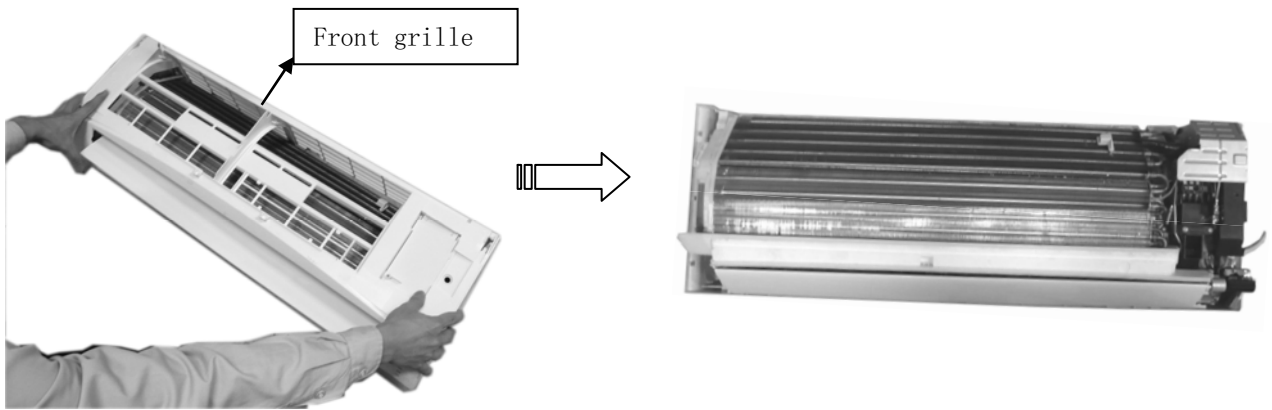

Removal Procedure for Main Electronic Controller

1. After front grille is taking off, remove the cover of control board and holder, then the Main PCB can be seen.

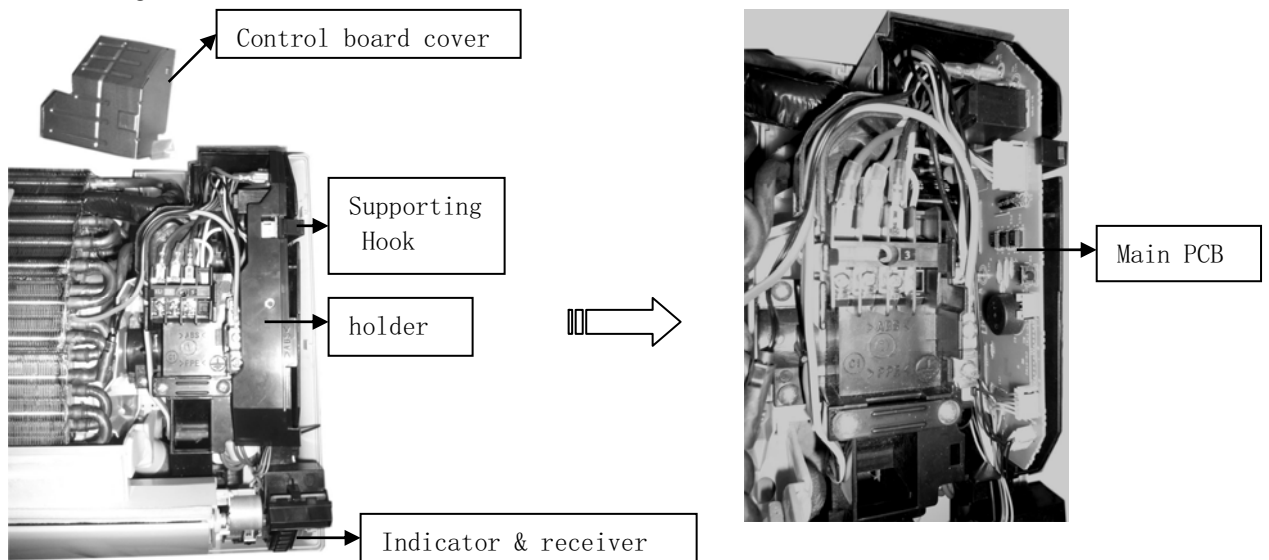

3. Drag out the supporting hook to the right side and pull up a bit the main PCB. Then release the lead wire connecting to CN-FM, CN-STM3, CN-DISP1-A, earth wire (Yellow/Green) and take out the sensor from the holder on evaporator. Pull out the whole electronic controller. Be sure to avoid cracking of the supporting hook.

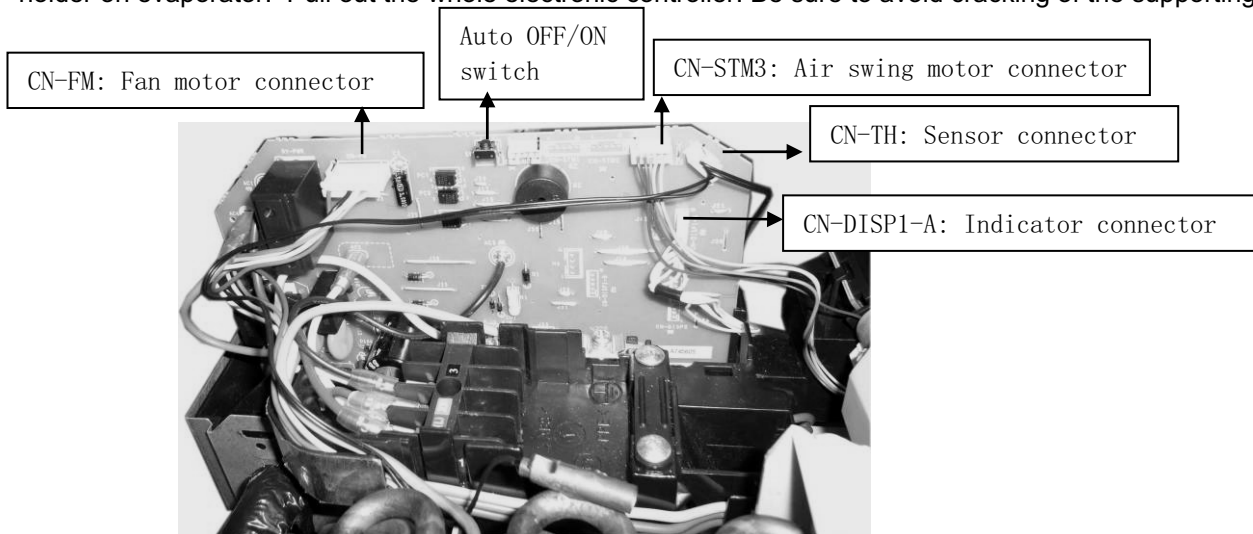

4. Remove the control board complete
Loose the screws of control board complete, then the whole control board can be pulled out.

Removal Procedure for Main Electronic Controller

1. Separate the drain hose and the drain plate.
2. Pull out the discharge grille slightly.

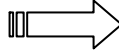
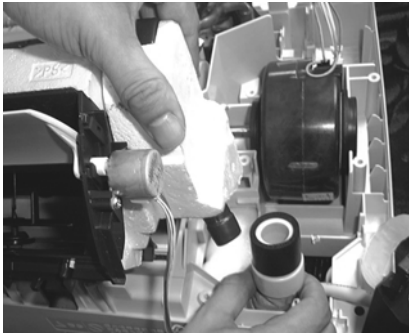

Removal Procedure for Cross Flow Fan

1. Release fixing screws on both side, disassembly the fixing board from evaporator on the left side and pull out the whole evaporator.

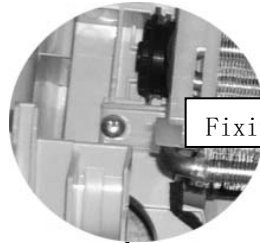

Fixing Screw

Fixing board

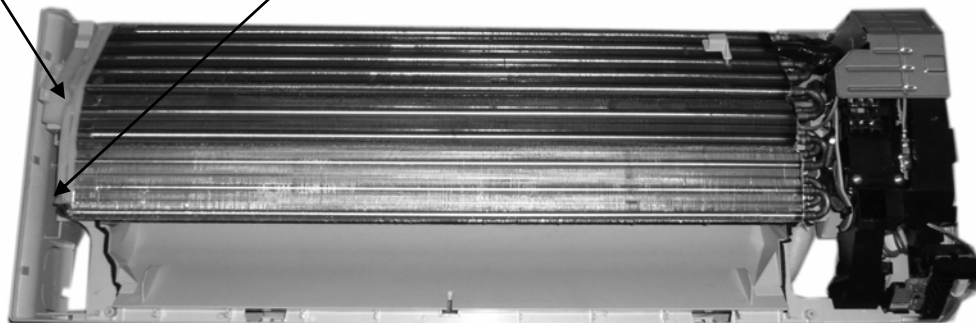

2. Loose the fixing screw of the cross flow fan.
3. After removing the bearing, indoor fan can be taken out from the left side
4. Lift up the indoor fan slightly, and then pull the fan motor out.

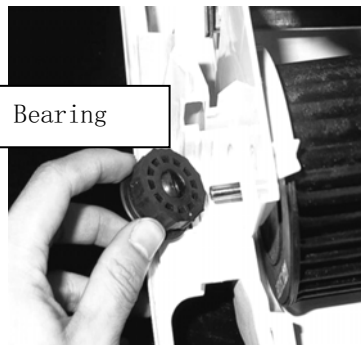
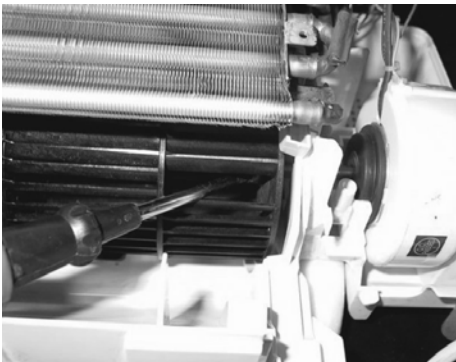

Bearing

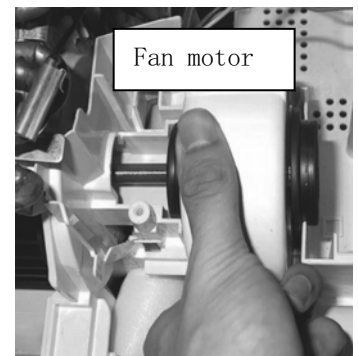

Fan motor

16. Exploded View and Replacement Parts List

16.1 Indoor Unit

CS-RE9JKE, CS-RE12JKE, CS-RE15JKE

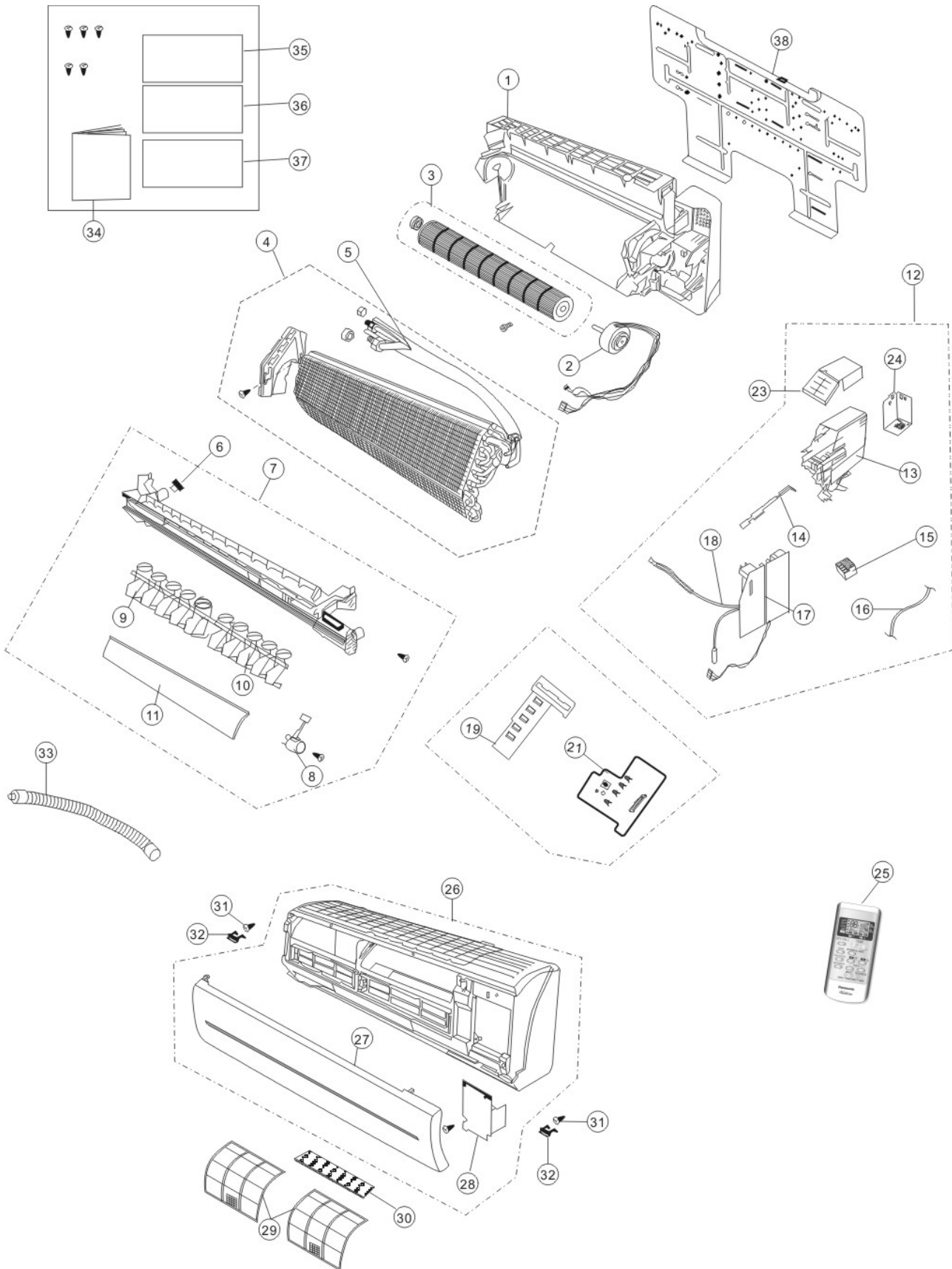

NO	PART NAME&DESCRIPTION	Q' TY	CS-RE9JKE	CS-RE12JKE	CS-RE15JKE	RE
1	CHASSIS COMPLETE	1	CWD50C1616	CWD50C1616	CWD50C1616	
2	FAN MOTOR	1	ARW6102AC	ARW6102AC	ARW6102AC	
3	CROSS FLOW FAN COMPLETE	1	CWH02C1080	CWH02C1080	CWH02C1080	
4	EVAPORATOR	1	CWB30C2811	CWB30C2811	CWB30C2994	
5	AUXILIARY TUBE ASS'Y	1	CWT01C4858	CWT01C4858	CWT01C4844	
6	AIR PLUG	1	CWH521096	CWH521096	CWH521096	
7	DISCHARGE GRILLE COMPLETE	1	CWE20C2970	CWE20C2970	CWE20C2970	
8	AIR SWING MOTOR	1	CWA981091	CWA981091	CWA981091	
9	HORIZONTAL AIR FLOW VANE (L)	1	CWE24C1292	CWE24C1292	CWE24C1292	
10	HORIZONTAL AIR FLOW VANE (R)	1	CWE24C1291	CWE24C1291	CWE24C1291	
11	VERTICAL AIR FLOW VANE	1	CWE241295	CWE241295	CWE241295	
12	C-BOX	1	CWH14C6817	CWH14C6818	CWH14C6819	
13	CONTROL BOARD CASING	1	CWH102377	CWH102377	CWH102377	
14	PARTICULAR PIECE	1	CWD933089	CWD933089	CWD933089	
15	TERMINAL BOARD COMPLETE	1	CWA28C2383	CWA28C2383	CWA28C2442	
16	POWER SUPPLY CORD COMPLETE	1	CWA20C2862	CWA20C2862	CWA20C2894	
17	MAIN PCB	1	CWA73C3612	CWA73C3613	CWA73C3614	
18	SENSOR	1	CWA50C2596	CWA50C2596	CWA50C2596	
19	INDICATOR HOLDER-FRONT	1	CWD933087	CWD933087	CWD933087	
21	INDICATOR PCB	1	CWA745415	CWA745415	CWA745415	
23	CONTROL BOARD TOP COVER	1	CWH131359	CWH131359	CWH131359	
24	CONTROL BOARD BACK COVER	1	CWH131358	CWH131358	CWH131358	
25	REMOTE CONTROL	1	CWA75C3077	CWA75C3077	CWA75C3077	
26	FRONT GRILLE COMPLETE	1	CWE11C4267	CWE11C4267	CWE11C4267	
27	INTAKE GRILLE	1	CWE22K1498	CWE22K1498	CWE22K1498	
28	GRILLE DOOR	1	CWE14C1039	CWE14C1039	CWE14C1039	
29	AIR FILTER	2	CWD001285	CWD001285	CWD001285	
30	ALIRUBUSTER FILTER	1	CWD001202	CWD001202	CWD001202	
31	SCREW-FRONT GRILLE	2	XTT4+16CFJ	XTT4+16CFJ	XTT4+16CFJ	
32	CAP-FRONT GRILLE	2	CWH521196	CWH521196	CWH521196	
33	DRAIN HOSE	1	CWH851136	CWH851136	CWH851136	
34	OPERATING INSTRUCTIONS	1	CWF566618	CWF566618	CWF566618	
35	INSTALLATION INSTRUCTION	1	CWF613856	CWF613856	CWF613856	
36	INSTALLATION INSTRUCTION	1	CWF613857	CWF613857	CWF613857	
37	INSTALLATION INSTRUCTION	1	CWF613858	CWF613858	CWF613858	
38	INSTALLATION PLATE	1	CWH361105	CWH361105	CWH361105	

(Note)

- All parts are supplied from PHAAG, China

16.2 Outdoor Unit

CU-RE9JKE, CU-RE12JKE

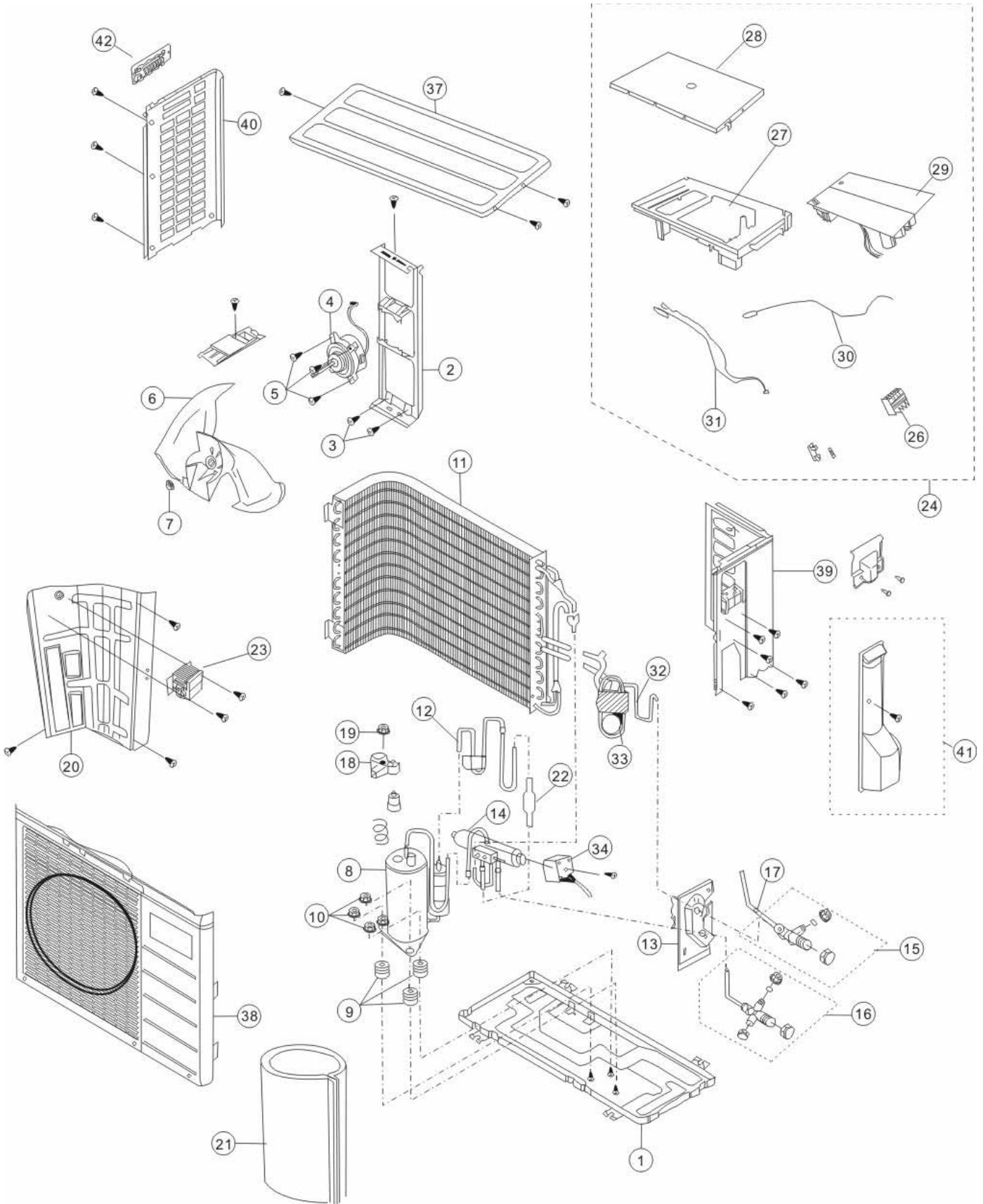

NO	PART NAME&DESCRIPTION	Q'TY	CU-RE9JKE	CU-RE12JKE	RE
1	CHASSIS ASS'Y	1	CWD50K2193A	CWD50K2193A	
2	FAN MOTOR BRACKET	1	CWD541123	CWD541123	
3	SCREW-FAN MOTOR BRACKET	2	CWH551148A	CWH551148A	
4	FAN MOTOR	1	CWA951654	CWA951656	
5	SCREW-FAN MOTOR MOUNT	3	CWH55406J	CWH55406J	
6	PROPELLER FAN ASS'Y	1	CWH03K1034	CWH03K1034	
7	NUT-PROPELLER FAN	1	CWH561036J	CWH561036J	
8	COMPRESSOR	1	CWB092256	CWB092256	
9	ANTI-VIBRATION BUSHING	3	CWH50077	CWH50077	
10	NUT-COMPRESSOR MOUNT	3	CWH56000J	CWH56000J	
11	CONDENSER	1	CWB32C2386	CWB32C2182	
12	TUBE ASSY	1	CWT023064	CWT023064	
13	HOLDER COUPLING ASS'Y	1	CWH351071	CWH351071	
14	4-WAY VALVE	1	CWB001037J	CWB001037J	
15	2-WAY VALVE	1	CWB021497	B021497	
16	3-WAY VALVE	1	CWB011603	CWB011603	
17	STRAINER	1	CWB111026	CWB111026	
18	TERMINAL COVER	1	CWH171048	CWH171048	
19	NUT FOR TERMIANL COVER	1	7080300J	7080300J	
20	SOUND PROOF BOARD	1	CWH151187	CWH151187	
21	SOUND PROOF MATERIAL	1	CWG302433	CWG302433	
22	TUBE (NOISE SUPPRESSOR)	1	CWB121016	CWB121016	
23	REACTOR	1	G0C193J00007	G0C193J00007	
24	CONTROL BOX COMPLETE	1	CWH14C6793	CWH14C6794	
26	TERMINAL BOARD ASS'Y	1	CWA28K1185	CWA28K1185	
27	CONTROL BOARD CASING	1	CWH102298	CWH102298	
28	COVER-CONTROL BOX	1	CWH131300	CWH131300	
29	ELECTRONIC CONTROLLER	1	CWA73C3609	CWA73C3610	
30	SENSOR COMPLETE (COMP.)	1	CWA50C2209J	CWA50C2209J	
31	SENSOR COMPLETE(PIPING)	1	CWA50C2521	CWA50C2521	
32	TUBE ASS'Y(CAPILLARY)	1	CWT01C4907	CWT01C4908	
33	CAPILLARY	1	CWB15471	CWB15323	
	CAPILLARY	1	----	CWB15395	
34	V-COIL COMPLETE	1	CWA43C2261	CWA43C2261	
35	CONTROL BOARD COVER(IN)	1	CWH131354	CWH131354	
37	TOP PLATE	1	CWE031084A	CWE031084A	
38	CABINET FRONT PLATE	1	CWE06C1231	CWE06C1231	
39	CABINET SIDE PLATE (R)	1	CWE041301A	CWE041301A	
40	CABINET SIDE PLATE (L)	1	CWE041247A	CWE041247A	
41	CONTROL BOARD COVER(OUT)	1	CWH131277	CWH131277	
42	HANDLE	1	CWE161001	CWE161001	

(Note)

- All parts are supplied from PHAAG, China.

CU-RE15JKE

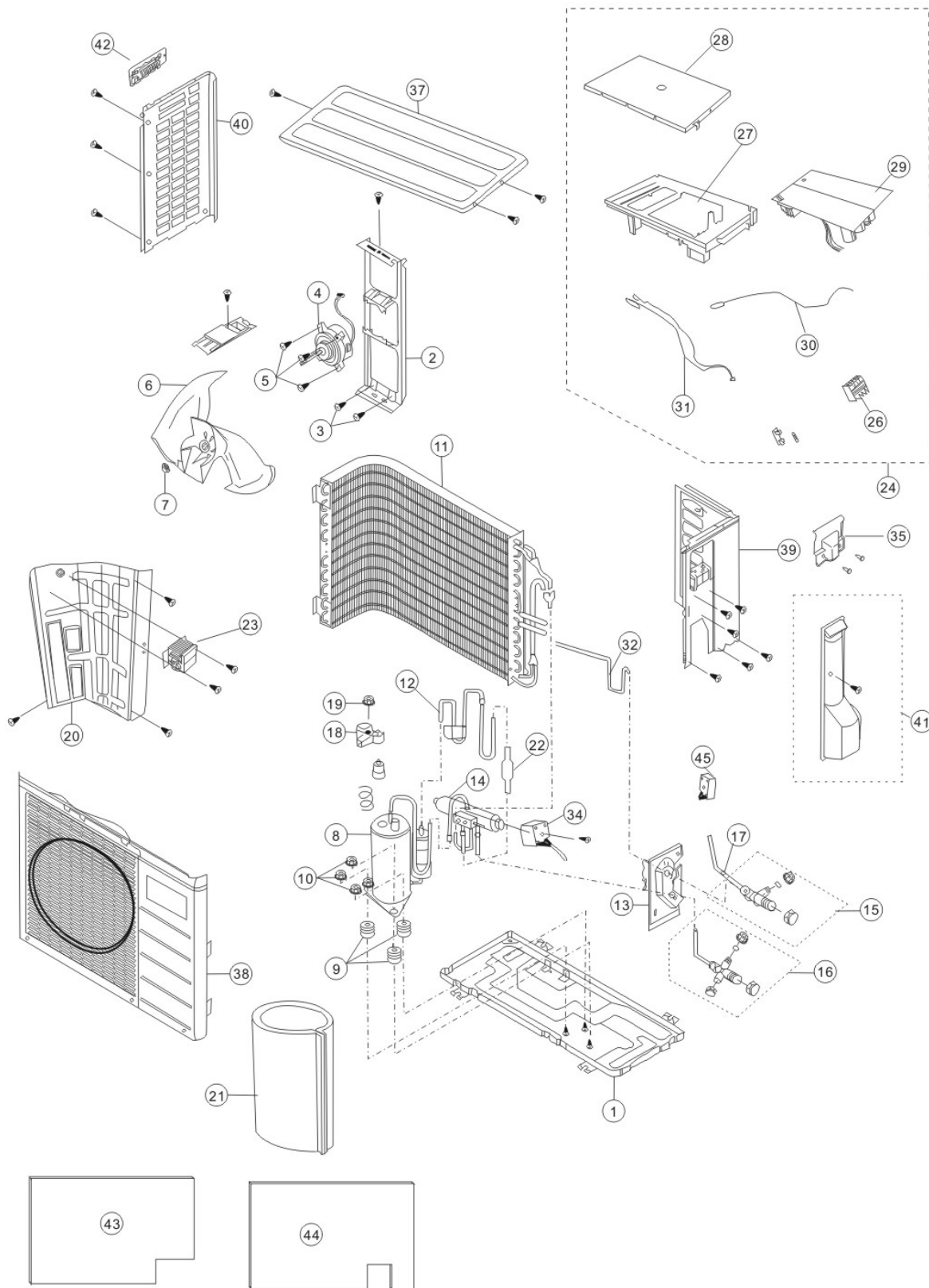

NO	PART NAME&DESCRIPTION	Q'TY	CU-RE15JKE	RE
1	CHASSIS ASS'Y	1	CWD50K2175A	
2	FAN MOTOR BRACKET	1	CWD541123	
3	SCREW-FAN MOTOR BRACKET	2	CWH551148A	
4	FAN MOTOR	1	ARS44E8P40AC	
5	SCREW-FAN MOTOR MOUNT	3	CWH55252J	
6	PROPELLER FAN ASS'Y	1	CWH03K1014	
7	NUT-PROPELLER FAN	1	CWH561034J	
8	COMPRESSOR	1	CWB092398	
9	ANTI-VIBRATION BUSHING	3	CWH50077	
10	NUT-COMPRESSOR MOUNT	3	CWH56000J	
11	CONDENSER	1	CWB32C2717	
12	TUBE ASSY	1	CWT024640	
13	HOLDER COUPLING ASS'Y	1	CWH351070	
14	4-WAY VALVE	1	CWB001038J	
15	2-WAY VALVE	1	CWB021497	
16	3-WAY VALVE	1	CWB011505	
17	STRAINER	1	CWB111026	
18	TERMINAL COVER	1	CWH171048	
19	NUT FOR TERMIANL COVER	1	7080300J	
20	SOUND PROOF BOARD	1	CWH151199	
21	SOUND PROOF MATERIAL	1	CWG302303	
22	TUBE (NOISE SUPPRESSOR)	1	CWB14011	
23	REACTOR	1	G0C203J00004	
24	CONTROL BOX COMPLETE	1	CWH14C6795	
26	TERMINAL BOARD ASS'Y	1	CWA28K1185	
27	CONTROL BOARD CASING	1	CWH102243	
28	COVER-CONTROL BOX	1	CWH131206	
29	ELECTRONIC CONTROLLER	1	CWA73C3611	
30	SENSOR COMPLETE (COMP.)	1	CWA50C2209J	
31	SENSOR COMPLETE(PIPING)	1	CWA50C2509	
32	TUBE ASS'Y	1	CWT026380	
33	EXPANSION VALE	1	CWB051030	
34	V-COIL COMPLETE FOR 4-WAY VALVE	1	CWA43C2144J	
35	CONTROL BOARD COVER(IN)	1	CWH131354	
37	TOP PLATE	1	CWE031085A	
38	CABINET FRONT PLATE	1	CWE06C1231	
39	CABINET SIDE PLATE (R)	1	CWE041308A	
40	CABINET SIDE PLATE (L)	1	CWE041247A	
41	CONTROL BOARD COVER(OUT)	1	CWH131277	
42	HANDLE	1	CWE161001	
43	SOUND PROOF MATERIAL	1	CWG302349	
44	SOUND PROOF MATERIAL	1	CWG302112	
45	V-COIL COMPLETE FOR EXPANSION VALVE	1	CWA43C2257	

(Note)

- All parts are supplied from PHAAG, China.

Printed in China