

Service Manual

Air Conditioner

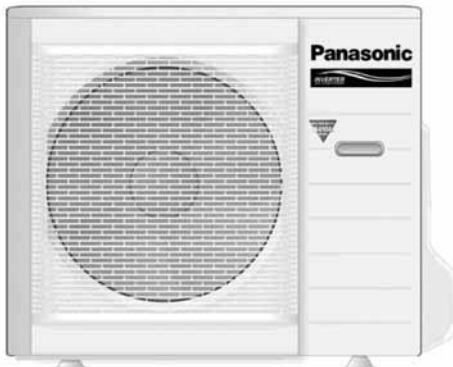
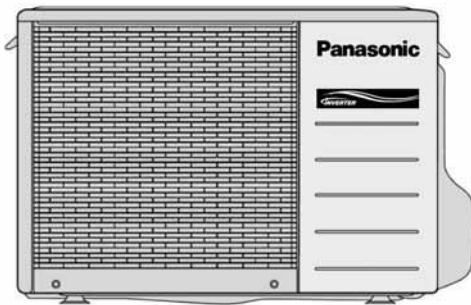

Indoor Unit	Outdoor Unit
CS-E7JKEW	CU-E7JKE
CS-E9JKEW	CU-E9JKE
CS-E12JKEW	CU-E12JKE
CS-E15JKEW	CU-E15JKE
CS-E15JKEW	CU-E15JKE-1
CS-E7JKEW-3	CU-E7JKE-3
CS-E9JKEW-3	CU-E9JKE-3
CS-E12JKEW-3	CU-E12JKE-3
CS-XE7JKEW	CU-E7JKE
CS-XE9JKEW	CU-E9JKE
CS-XE12JKEW	CU-E12JKE
CS-XE15JKEW	CU-E15JKE
CS-XE7JKEW	CU-E7JKE-3
CS-XE9JKEW	CU-E9JKE-3
CS-XE12JKEW	CU-E12JKE-3
CS-XE15JKEW	CU-E15JKE-1

Please file and use this manual together with the service manual for Model No. CU-2E18CBPG, CU-3E23CBPG, CU-4E27CBPG, Order No. RAC0209005C2, Model No. CU-3E18EBE, Order No. RAC0602011C2 and Model No. CU-2E15GBE, Order No. MAC0704001A2.

⚠ WARNING

This service information is designed for experienced repair technicians only and is not designed for use by the general public. It does not contain warnings or cautions to advise non-technical individuals of potential dangers in attempting to service a product. Products powered by electricity should be serviced or repaired only by experienced professional technicians. Any attempt to service or repair the product or products dealt with in this service information by anyone else could result in serious injury or death.

⚠ PRECAUTION OF LOW TEMPERATURE

In order to avoid frostbite, be assured of no refrigerant leakage during the installation or repairing of refrigeration circuit.

TABLE OF CONTENTS

	PAGE		PAGE
1 Safety Precautions	3	2 Specifications	5

Panasonic®

© Panasonic HA Air-Conditioning (M) Sdn. Bhd. 2008.
Unauthorized copying and distribution is a violation of law.

3 Features -----	26		
4 Location of Controls and Components -----	27		
4.1. Indoor Unit-----	27		
4.2. Outdoor Unit-----	27		
4.3. Remote Control-----	27		
5 Dimensions -----	28		
5.1. Indoor Unit-----	28		
5.2. Outdoor Unit-----	29		
6 Refrigeration Cycle Diagram -----	30		
6.1. CU-E7JKE CU-E9JKE CU-E12JKE CU- E15JKE-1-----	30		
6.2. CU-E7JKE-3 CU-E9JKE-3 CU-E12JKE-3-----	31		
6.3. CU-E15JKE-----	32		
7 Block Diagram -----	33		
7.1. CU-E7JKE CU-E9JKE CU-E12JKE CU- E15JKE-1-----	33		
7.2. CU-E7JKE-3 CU-E9JKE-3 CU-E12JKE-3-----	34		
7.3. CU-E15JKE-----	35		
8 Wiring Connection Diagram -----	36		
8.1. Indoor Unit-----	36		
8.2. Outdoor Unit-----	37		
9 Electronic Circuit Diagram -----	41		
9.1. Indoor Unit-----	41		
9.2. Outdoor Unit-----	42		
10 Printed Circuit Board -----	46		
10.1. Indoor Unit-----	46		
10.2. Outdoor Unit-----	49		
11 Installation Instruction -----	52		
11.1. Select the Best Location-----	52		
11.2. Indoor Unit-----	53		
11.3. Outdoor Unit-----	56		
12 Operation and Control -----	59		
12.1. Basic Function-----	59		
12.2. Indoor Fan Motor Operation-----	60		
12.3. Outdoor Fan Motor Operation-----	61		
12.4. Airflow Direction-----	61		
12.5. Quiet operation (Cooling Mode/Cooling area of Dry Mode)-----	62		
12.6. Quiet operation (Heating)-----	62		
12.7. Powerful Mode Operation-----	63		
12.8. Timer Control-----	63		
12.9. Auto Restart Control-----	63		
12.10. Indication Panel-----	64		
12.11. Patrol Operation-----	64		
12.12. e-ion Operation-----	66		
12.13. Mild Dry Cooling Operation-----	68		
13 Protection Control -----	69		
13.1. Protection Control For All Operations-----	69		
13.2. Protection Control For Cooling & Soft Dry Operation-----	71		
13.3. Protection Control For Heating Operation-----	72		
14 Servicing Mode -----	73		
14.1. Auto OFF/ON Button-----	73		
14.2. Remote Control Button-----	74		
15 Troubleshooting Guide -----	75		
15.1. Refrigeration Cycle System-----	75		
15.2. Breakdown Self Diagnosis Function-----	77		
15.3. Error Codes Table-----	78		
15.4. Self-diagnosis Method-----	80		
16 Disassembly and Assembly Instructions -----	110		
		16.1. Indoor Electronic Controllers, Cross Flow Fan and Indoor Fan Motor Removal Procedures-----	110
		16.2. Outdoor Electronic Controller Removal Procedure-----	114
		17 Technical Data -----	116
		17.1. Operation Characteristics-----	116
		17.2. Sensible Capacity Chart-----	148
		18 Exploded View and Replacement Parts List -----	149
		18.1. Indoor Unit-----	149
		18.2. Outdoor Unit-----	156

1 Safety Precautions

- Read the following “SAFETY PRECAUTIONS” carefully before perform any servicing.
- Electrical work must be installed or serviced by a licensed electrician. Be sure to use the correct rating of the power plug and main circuit for the model installed.
- The caution items stated here must be followed because these important contents are related to safety. The meaning of each indication used is as below. Incorrect installation or servicing due to ignoring of the instruction will cause harm or damage, and the seriousness is classified by the following indications.





 WARNING	This indication shows the possibility of causing death or serious injury.
--	---



 CAUTION	This indication shows the possibility of causing injury or damage to properties.
--	--

- The items to be followed are classified by the symbols:







	This symbol denotes item that is PROHIBITED from doing.
---	---

- Carry out test run to confirm that no abnormality occurs after the servicing. Then, explain to user the operation, care and maintenance as stated in instructions. Please remind the customer to keep the operating instructions for future reference.

 WARNING	
1. Do not modify the machine, part, material during repairing service.	
2. If wiring unit is supplied as repairing part, do not repair or connect the wire even only partial wire break. Exchange the whole wiring unit.	
3. Do not wrench the fasten terminal. Pull it out or insert it straightly.	
4. Engage dealer or specialist for installation and servicing. If installation or servicing done by the user is defective, it will cause water leakage, electrical shock or fire.	
5. Install according to this installation instructions strictly. If installation is defective, it will cause water leakage, electrical shock or fire.	
6. Use the attached accessories parts and specified parts for installation and servicing. Otherwise, it will cause the set to fall, water leakage, fire or electrical shock.	
7. Install at a strong and firm location which is able to withstand the set's weight. If the strength is not enough or installation is not properly done, the set will drop and cause injury.	
8. For electrical work, follow the local national wiring standard, regulation and the installation instruction. An independent circuit and single outlet must be used. If electrical circuit capacity is not enough or defect found in electrical work, it will cause electrical shock or fire.	
9. This equipment is strongly recommended to install with Earth Leakage Circuit Breaker (ELCB) or Residual Current Device (RCD). Otherwise, it may cause electrical shock and fire in case equipment breakdown or insulation breakdown.	
10. Use the specified cable 4 x 1.5mm ² , and connect tightly for indoor/outdoor connection. Connect tightly and clamp the cable so that no external force will be acted on the terminal. If connection or fixing is not perfect, it will cause heat-up or fire at the connection.	
11. Wire routing must be properly arranged so that control board cover is fixed properly. If control board cover is not fixed perfectly, it will cause heat-up or fire at connection point of terminal, fire or electrical shock.	
12. When carrying out piping connection, take care not to let air substances other than the specified refrigerant go into refrigeration cycle. Otherwise, it will cause lower capacity, abnormal high pressure in the refrigeration cycle, explosive and injury.	
13. Do not install outdoor unit near handrail of veranda. When installing air-conditioner unit at veranda of high rise building, child may climb up to outdoor unit and cross over the handrail and causing accident.	
14. This equipment must be properly earthed. Earth line must not be connected to gas pipe, water pipe, earth of lightning rod and telephone. Otherwise, it may cause electric shock in case equipment breakdown or insulation breakdown.	
15. Keep away from small children, the thin film may cling to nose and mouth and prevent breathing.	
16. Do not damage or use unspecified power supply cord. Otherwise it will cause fire or electric shock.	
17. Do not modify the length of the power supply cord or use extension cord, and do not share the single outlet with other electrical appliances. Otherwise, it will cause fire or electric shock.	

18. In case of using existing (R22) pipes during installation of R410 models, must carry out pump down properly to collect back the refrigerant and oil before installation new unit. Thickness of copper pipes used with R410A must be more than 0.8mm. Never use copper pipes thinner than 0.8mm. It is desirable that the amount of residual oil is less than 40 mg/10m.	
19. During installation, before run the compressor, confirm the refrigerant pipes are fixed. Operation of compressor without fixing the piping, setting the valves at open condition, a burst may occur and cause injury.	
20. During pump down operation, stop the compressor before remove the refrigerant piping. When remove piping while valves at open condition, burst may occur and cause injury.	
21. After completion of installation or service, confirm there is no leakage or refrigerant gas. It may generate toxic gas when the refrigerant contacts with fire.	
22. Ventilate if there is refrigerant gas leakage during operation. It may cause toxic gas when refrigerant contacts with fire.	
23. Do not insert your fingers or other objects into the unit, high speed rotating fan may cause injury.	
24. Must not use other parts except original parts describe in catalog and manual.	

 **CAUTION**

1. Do not install the unit at place where leakage of flammable gas may occur. In case gas leaks and accumulates at surrounding of the unit, it may cause fire.	
2. Carry out drainage piping as mentioned in installation instructions. If drainage is not perfect, water may enter the room and damage the furniture.	
3. Tighten the flare nut with torque wrench according to specified method. If the flare nut is over-tightened, after a long period, the flare may break and cause refrigerant gas leakage.	
4. Do not touch outdoor unit air inlet and aluminium fin. It may cause injury.	
5. Select an installation location which is easy for maintenance.	
6. Pb free solder has a higher melting point than standard solder; typically the melting point is 50°F - 70°F (30°C - 40°C) higher. Please use a high temperature solder iron. In case of the soldering iron with temperature control, please set it to 700 ± 20°F (370 ± 10°C). Pb free solder will tend to splash when heated too high (about 1100°F / 600°C).	
7. Power supply connection to the air conditioner. Connect the power supply cord of the air conditioner to the mains using one of the following methods. Power supply point shall be the place where there is ease for access for the power disconnection in case of emergency. In some countries, permanent connection of this room air conditioner to the power supply is prohibited. i. Power supply connection to the receptacle using a power plug. Use an approved 15/16A (3/4~1.75HP), 16A (2.0HP), 20A (2.5HP) or 25A (3.0HP) power plug with earth pin for the connection to the socket. ii. Power supply connection to a circuit breaker for the permanent connection. Use an approved 16A (3/4~2.0HP), 20A (2.5HP) or 25A (3.0HP) circuit breaker for the permanent connection. It must be a double pole switch with a minimum 3.0 mm contact gap.	
8. Do not release refrigerant during piping work for installation, servicing, reinstallation and during repairing a refrigerant parts. Take care of the liquid refrigerant, it may cause frostbite.	
9. Installation or servicing work: It may need two people to carry out the installation or servicing work.	
10. Do not install this appliance in a laundry room or other location where water may drip from the ceiling, etc.	
11. Do not sit or step on the unit, you may fall down accidentally.	
12. Do not touch the sharp aluminium fin, sharp parts may cause injury.	

2 Specifications

MODEL			INDOOR	CS-E7JKEW, CS-XE7JKEW			CS-E9JKEW, CS-XE9JKEW		
			OUTDOOR	CU-E7JKE			CU-E9JKE		
Performance Test Condition			EUROVENT			EUROVENT			
Power Supply			Phase, Hz	Single, 50			Single, 50		
			V	230			230		
			Min.	Mid.	Max.	Min.	Mid.	Max.	
Cooling	Capacity		kW	0.70	2.05	2.40	0.80	2.50	3.00
			BTU/h	2390	6990	8180	2730	8530	10200
			Kcal/h	600	1760	2060	690	2150	2580
	Running Current		A	—	2.2	—	—	2.6	—
	Input Power		W	170	470	580	175	545	740
	Annual Consumption		kWh	—	235	—	—	273	—
	EER		W/W	4.12	4.36	4.14	4.57	4.59	4.05
			Kcal/hW	3.53	3.74	3.55	3.94	3.94	3.49
	Power Factor		%	—	93	—	—	91	—
	Indoor Noise (H / L / QLo)		dB-A	37 / 24 / 20			39 / 25 / 20		
			Power Level dB	53 / 40 / 36			55 / 41 / 36		
	Outdoor Noise (H / L)		dB-A	45 / -			46 / -		
			Power Level dB	60 / -			61 / -		
Heating	Capacity		kW	0.70	2.80	4.00	0.80	3.40	5.00
			BTU/h	2390	9550	13600	2730	11600	17100
			Kcal/h	600	2410	3440	690	2920	4300
	Running Current		A	—	3.0	—	—	3.4	—
	Input Power		W	160	635	1.02k	165	740	1.31k
	COP		W/W	4.38	4.41	3.92	4.85	4.59	3.82
			Kcal/hW	3.75	3.80	3.37	4.18	3.95	3.28
	Power Factor		%	—	92	—	—	95	—
	Indoor Noise (H / L / QLo)		dB-A	38 / 25 / 22			40 / 27 / 24		
			Power Level dB	54 / 41 / 38			56 / 43 / 40		
	Outdoor Noise (H / L)		dB-A	46 / -			47 / -		
			Power Level dB	61 / -			62 / -		
	Low Temp. : Capacity (kW) / I.Power (W) / COP			2.90 / 900 / 3.22			3.62 / 1.16k / 3.12		
Extr Low Temp. : Capacity (kW) / I.Power (W) / COP			2.35 / 930 / 2.53			2.88 / 1.19k / 2.42			
Max Current (A) / Max Input Power (W)			4.7 / 1.02k			5.8 / 1.31k			
Starting Current (A)			3.0			3.4			
Compressor		Type	Hermetic Motor			Hermetic Motor			
		Motor Type	Brushless (6-poles)			Brushless (6-poles)			
		Output Power	W	650			700		
Indoor Fan	Type		Cross-flow Fan			Cross-flow Fan			
	Material		ASG20K1			ASG20K1			
	Motor Type		Transistor (8-poles)			Transistor (8-poles)			
	Input Power		W	—			—		
	Output Power		W	40			40		
	Speed		QLo	Cool	rpm	590	630		
				Heat	rpm	680	770		
	Speed		Lo	Cool	rpm	670	740		
				Heat	rpm	730	830		
	Speed		Me	Cool	rpm	860	950		
				Heat	rpm	910	1030		
	Speed		Hi	Cool	rpm	1050	1170		
				Heat	rpm	1090	1240		
Speed		SHi	Cool	rpm	1110	1240			
			Heat	rpm	1150	1320			

MODEL		INDOOR		CS-E7JKEW, CS-XE7JKEW		CS-E9JKEW, CS-XE9JKEW		
		OUTDOOR		CU-E7JKE		CU-E9JKE		
Outdoor Fan	Type			Propeller Fan		Propeller Fan		
	Material			PP		PP		
	Motor Type			Induction (6-poles)		Induction (6-poles)		
	Input Power	W		62		65		
	Output Power	W		25		25		
	Speed	Hi	rpm		750		770	
Moisture Removal		L/h (Pt/h)		1.3 (2.7)		1.5 (3.2)		
Indoor Airflow	QLo	Cool	m ³ /min (ft ³ /min)	5.6 (198)		4.9 (173)		
		Heat	m ³ /min (ft ³ /min)	6.6 (233)		6.5 (230)		
	Lo	Cool	m ³ /min (ft ³ /min)	6.5 (230)		6.1 (215)		
		Heat	m ³ /min (ft ³ /min)	7.2 (254)		7.2 (254)		
	Me	Cool	m ³ /min (ft ³ /min)	8.7 (307)		8.7 (307)		
		Heat	m ³ /min (ft ³ /min)	9.3 (328)		9.6 (339)		
	Hi	Cool	m ³ /min (ft ³ /min)	10.9 (385)		11.3 (400)		
		Heat	m ³ /min (ft ³ /min)	11.4 (400)		11.9 (420)		
	SHi	Cool	m ³ /min (ft ³ /min)	11.6 (410)		11.9 (420)		
		Heat	m ³ /min (ft ³ /min)	12.0 (424)		13.1 (463)		
Outdoor Airflow	Hi	Cool	m ³ /min (ft ³ /min)	28.8 (1020)		29.8 (1050)		
		Heat	m ³ /min (ft ³ /min)	28.8 (1020)		29.8 (1050)		
Refrigeration Cycle	Control Device			Check Valve & Capillary Tube		Check Valve & Capillary Tube		
	Refrigerant Oil	cm ³		RB68A or Freol Alpha 68M (320)		RB68A or Freol Alpha 68M (320)		
	Refrigerant Type	g (oz)		R410A, 780 (27.5)		R410A, 960 (33.9)		
Dimension	Height (I/D / O/D)	mm (inch)		290 (11-7/16) / 540 (21-9/32)		290 (11-7/16) / 540 (21-9/32)		
	Width (I/D / O/D)	mm (inch)		870 (34-9/32) / 780 (30-23/32)		870 (34-9/32) / 780 (30-23/32)		
	Depth (I/D / O/D)	mm (inch)		204 (8-1/16) / 289 (11-13/32)		204 (8-1/16) / 289 (11-13/32)		
Weight	Net (I/D / O/D)	kg (lb)		9 (20) / 33 (73)		9 (20) / 34 (75)		
Piping	Pipe Diameter (Liquid / Gas)		mm (inch)		6.35 (1/4) / 9.52 (3/8)		6.35 (1/4) / 9.52 (3/8)	
	Standard Length		m (ft)		5 (16.4)		5 (16.4)	
	Length Range (min - max)		m (ft)		3 (9.8) ~ 15 (49.2)		3 (9.8) ~ 15 (49.2)	
	I/D & O/D Height Different		m (ft)		15.0 (49.2)		15.0 (49.2)	
	Additional Gas Amount		g/m (oz/ft)		20 (0.2)		20 (0.2)	
	Length for Additional Gas		m (ft)		7.5 (24.6)		7.5 (24.6)	
Drain Hose	Inner Diameter	mm		16		16		
	Length	mm		650		650		
Indoor Heat Exchanger	Fin Material			Aluminium (Pre Coat)		Aluminium (Pre Coat)		
	Fin Type			Slit Fin		Slit Fin		
	Row x Stage x FPI			2 x 15 x 17		2 x 15 x 19		
	Size (W x H x L)	mm		610 x 315 x 25.4		610 x 315 x 25.4		
Outdoor Heat Exchanger	Fin Material			Aluminium		Aluminium		
	Fin Type			Corrugated Fin		Corrugated Fin		
	Row x Stage x FPI			2 x 24 x 17		2 x 24 x 17		
	Size (W x H x L)	mm		36.4 x 504 x 713 684		36.4 x 504 x 713 684		
Air Filter	Material			Polypropelene		Polypropelene		
	Type			One-touch		One-touch		
Power Supply				Outdoor Power Supply		Outdoor Power Supply		
Power Supply Cord		A		Nil		Nil		
Thermostat				Electronic Control		Electronic Control		
Protection Device				Electronic Control		Electronic Control		

MODEL		INDOOR	CS-E7JKEW, CS-XE7JKEW		CS-E9JKEW, CS-XE9JKEW	
		OUTDOOR	CU-E7JKE		CU-E9JKE	
			Dry Bulb	Wet Bulb	Dry Bulb	Wet Bulb
Indoor Operation Range	Cooling	Maximum	32	23	32	23
		Minimum	16	11	16	11
	Heating	Maximum	30	—	30	—
		Minimum	16	—	16	—
Outdoor Operation Range	Cooling	Maximum	43	26	43	26
		Minimum	16	11	16	11
	Heating	Maximum	24	18	24	18
		Minimum	-5	-6	-5	-6

1. Cooling capacities are based on indoor temperature of 27°C Dry Bulb (80.6°F Dry Bulb), 19.0°C Wet Bulb (66.2°F Wet Bulb) and outdoor air temperature of 35°C Dry Bulb (95°F Dry Bulb), 24°C Wet Bulb (75.2°F Wet Bulb)
2. Heating capacities are based on indoor temperature of 20°C Dry Bulb (68°F Dry Bulb) and outdoor air temperature of 7°C Dry Bulb (44.6°F Dry Bulb), 6°C Wet Bulb (42.8°F Wet Bulb)
3. Heating low temperature capacity, Input Power and COP measured at 230 V, indoor temperature 20°C, outdoor 2/1°C
4. Heating extreme low temperature capacity, Input Power and COP measured at 230 V, indoor temperature 20°C, outdoor -7/-8°C
5. Specifications are subjected to change without prior notice for further improvement.

MODEL			INDOOR	CS-E12JKEW, CS-XE12JKEW			CS-E15JKEW, CS-XE15JKEW			
			OUTDOOR	CU-E12JKE			CU-E15JKE			
Performance Test Condition			EUROVENT			EUROVENT				
Power Supply			Phase, Hz	Single, 50			Single, 50			
			V	230			230			
			Min.	Mid.	Max.	Min.	Mid.	Max.		
Cooling	Capacity		kW	0.80	3.50	4.00	0.90	4.20	5.00	
			BTU/h	2730	11900	13600	3070	14300	17100	
			Kcal/h	690	3010	3440	770	3610	4300	
	Running Current		A	—	4.1	—	—	5.8	—	
	Input Power		W	185	905	1.18k	215	1.22k	1.60k	
	Annual Consumption		kWh	—	453	—	—	610	—	
	EER		W/W	4.32	3.87	3.39	4.19	3.44	3.13	
			Kcal/hW	3.73	3.33	2.92	3.58	2.96	2.69	
	Power Factor		%	—	96	—	—	92	—	
	Indoor Noise (H / L / QLo)		dB-A	42 / 28 / 20			43 / 32 / 29			
Power Level dB			58 / 44 / 36			59 / 48 / 45				
Outdoor Noise (H / L)		dB-A	48 / -			46 / -				
		Power Level dB	63 / -			61 / -				
Heating	Capacity		kW	0.80	4.40	6.70	0.90	5.40	7.10	
			BTU/h	2730	15000	22800	3070	18400	24200	
			Kcal/h	690	3780	5760	770	4640	6110	
	Running Current		A	—	5.1	—	—	6.9	—	
	Input Power		W	175	1.09k	1.93k	245	1.46k	2.21k	
	COP		W/W	4.57	4.04	3.47	3.67	3.70	3.21	
			Kcal/hW	3.94	3.47	2.98	3.14	3.18	2.76	
	Power Factor		%	—	93	—	—	92	—	
	Indoor Noise (H / L / QLo)		dB-A	42 / 33 / 30			43 / 35 / 32			
			Power Level dB	58 / 49 / 46			59 / 51 / 48			
Outdoor Noise (H / L)		dB-A	50 / -			46 / -				
		Power Level dB	65 / -			61 / -				
Low Temp. : Capacity (kW) / I.Power (W) / COP			4.85 / 1.67k / 2.90			5.14 / 1.96k / 2.62				
Extr Low Temp. : Capacity (kW) / I.Power (W) / COP			3.75 / 1.68k / 2.23			4.10 / 2.10k / 1.95				
Max Current (A) / Max Input Power (W)			8.9 / 1.93k			9.7 / 2.21k				
Starting Current (A)			5.1			6.9				
Compressor		Type	Hermetic Motor			Hermetic Motor				
		Motor Type	Brushless (6-poles)			Brushless (4-poles)				
		Output Power	W	700			900			
Indoor Fan	Type		Cross-flow Fan			Cross-flow Fan				
	Material		ASG20K1			ASG20K1				
	Motor Type		Transistor (8-poles)			Transistor (8-poles)				
	Input Power		W	—			—			
	Output Power		W	40			40			
	Speed	QLo	Cool	rpm	630			730		
			Heat	rpm	950			1000		
		Lo	Cool	rpm	830			870		
			Heat	rpm	1010			1080		
		Me	Cool	rpm	1040			1070		
			Heat	rpm	1150			1210		
		Hi	Cool	rpm	1260			1270		
			Heat	rpm	1300			1350		
SHi	Cool	rpm	1320			1340				
	Heat	rpm	1340			1370				

MODEL		INDOOR		CS-E12JKEW, CS-XE12JKEW		CS-E15JKEW, CS-XE15JKEW		
		OUTDOOR		CU-E12JKE		CU-E15JKE		
Outdoor Fan	Type			Propeller Fan		Propeller Fan		
	Material			PP		PP		
	Motor Type			Induction (6-poles)		Transistor (8-poles)		
	Input Power	W		70		—		
	Output Power	W		30		40		
	Speed	Hi	rpm		830		Cool : 660 Heat : 640	
Moisture Removal		L/h (Pt/h)		2.0 (4.2)		2.4 (5.1)		
Indoor Airflow		QLo	Cool	m ³ /min (ft ³ /min)	4.9 (173)		6.0 (212)	
			Heat	m ³ /min (ft ³ /min)	8.7 (307)		9.2 (325)	
		Lo	Cool	m ³ /min (ft ³ /min)	7.2 (254)		7.7 (272)	
			Heat	m ³ /min (ft ³ /min)	9.4 (332)		10.2 (360)	
		Me	Cool	m ³ /min (ft ³ /min)	9.7 (343)		10.1 (357)	
			Heat	m ³ /min (ft ³ /min)	11.0 (389)		11.7 (413)	
		Hi	Cool	m ³ /min (ft ³ /min)	12.5 (440)		12.5 (440)	
			Heat	m ³ /min (ft ³ /min)	12.8 (450)		13.4 (475)	
		SHi	Cool	m ³ /min (ft ³ /min)	13.1 (463)		13.3 (470)	
			Heat	m ³ /min (ft ³ /min)	13.3 (470)		13.6 (480)	
Outdoor Airflow		Hi	Cool	m ³ /min (ft ³ /min)	31.0 (1090)		48.5 (1710)	
			Heat	m ³ /min (ft ³ /min)	31.0 (1090)		46.8 (1650)	
Refrigeration Cycle		Control Device		Check Valve & Capillary Tube		Expansion Valve		
		Refrigerant Oil		cm ³	RB68A or Freol Alpha 68M (320)		RB68A or Freol Alpha 68M (400)	
		Refrigerant Type		g (oz)	R410A, 970 (34.2)		R410A, 1.06k (37.4)	
Dimension		Height (I/D / O/D)		mm (inch)	290 (11-7/16) / 540 (21-9/32)		290 (11-7/16) / 750 (29-17/32)	
		Width (I/D / O/D)		mm (inch)	870 (34-9/32) / 780 (30-23/32)		870 (34-9/32) / 875 (34-15/32)	
		Depth (I/D / O/D)		mm (inch)	204 (8-1/16) / 289 (11-13/32)		204 (8-1/16) / 345 (13-19/32)	
Weight		Net (I/D / O/D)		kg (lb)	9 (20) / 34 (75)		9 (20) / 48 (106)	
Piping	Pipe Diameter (Liquid / Gas)		mm (inch)	6.35 (1/4) / 9.52 (3/8)		6.35 (1/4) / 12.70 (1/2)		
	Standard Length		m (ft)	5 (16.4)		5 (16.4)		
	Length Range (min - max)		m (ft)	3 (9.8) ~ 15 (49.2)		3 (9.8) ~ 15 (49.2)		
	I/D & O/D Height Different		m (ft)	15.0 (49.2)		15.0 (49.2)		
	Additional Gas Amount		g/m (oz/ft)	20 (0.2)		20 (0.2)		
	Length for Additional Gas		m (ft)	7.5 (24.6)		7.5 (24.6)		
Drain Hose		Inner Diameter		mm	16		16	
		Length		mm	650		650	
Indoor Heat Exchanger		Fin Material		Aluminium (Pre Coat)		Aluminium (Pre Coat)		
		Fin Type		Slit Fin		Slit Fin		
		Row x Stage x FPI		2 x 15 x 21		2 x 15 x 21		
		Size (W x H x L)		mm	610 x 315 x 25.4		610 x 315 x 25.4	
Outdoor Heat Exchanger		Fin Material		Aluminium		Aluminium		
		Fin Type		Corrugated Fin		Corrugated Fin		
		Row x Stage x FPI		2 x 24 x 17		1 x 28 x 18		
		Size (W x H x L)		mm	36.4 x 504 x 713 684		22 x 711 x 835	
Air Filter		Material		Polypropelene		Polypropelene		
		Type		One-touch		One-touch		
Power Supply				Outdoor Power Supply		Outdoor Power Supply		
Power Supply Cord		A		Nil		Nil		
Thermostat				Electronic Control		Electronic Control		
Protection Device				Electronic Control		Electronic Control		

MODEL		INDOOR	CS-E12JKEW, CS-XE12JKEW		CS-E15JKEW, CS-XE15JKEW	
		OUTDOOR	CU-E12JKE		CU-E15JKE	
			Dry Bulb	Wet Bulb	Dry Bulb	Wet Bulb
Indoor Operation Range	Cooling	Maximum	32	23	32	23
		Minimum	16	11	16	11
	Heating	Maximum	30	—	30	—
		Minimum	16	—	16	—
Outdoor Operation Range	Cooling	Maximum	43	26	43	26
		Minimum	16	11	16	11
	Heating	Maximum	24	18	24	18
		Minimum	-5	-6	-5	-6

1. Cooling capacities are based on indoor temperature of 27°C Dry Bulb (80.6°F Dry Bulb), 19.0°C Wet Bulb (66.2°F Wet Bulb) and outdoor air temperature of 35°C Dry Bulb (95°F Dry Bulb), 24°C Wet Bulb (75.2°F Wet Bulb)
2. Heating capacities are based on indoor temperature of 20°C Dry Bulb (68°F Dry Bulb) and outdoor air temperature of 7°C Dry Bulb (44.6°F Dry Bulb), 6°C Wet Bulb (42.8°F Wet Bulb)
3. Heating low temperature capacity, Input Power and COP measured at 230 V, indoor temperature 20°C, outdoor 2/1°C
4. Heating extreme low temperature capacity, Input Power and COP measured at 230 V, indoor temperature 20°C, outdoor -7/-8°C
5. Specifications are subjected to change without prior notice for further improvement.

MODEL			INDOOR	CS-E7JKEW-3, CS-XE7JKEW			CS-E9JKEW-3, CS-XE9JKEW			
			OUTDOOR	CU-E7JKE-3			CU-E9JKE-3			
Performance Test Condition			EUROVENT			EUROVENT				
Power Supply			Phase, Hz	Single, 50			Single, 50			
			V	230			230			
			Min.	Mid.	Max.	Min.	Mid.	Max.		
Cooling	Capacity		kW	0.70	2.05	2.40	0.80	2.50	3.00	
			BTU/h	2390	6990	8180	2730	8530	10200	
			Kcal/h	600	1760	2060	690	2150	2580	
	Running Current		A	—	2.2	—	—	2.6	—	
	Input Power		W	170	470	580	175	545	740	
	Annual Consumption		kWh	—	235	—	—	273	—	
	EER		W/W	4.12	4.36	4.14	4.57	4.59	4.05	
			Kcal/hW	3.53	3.74	3.55	3.94	3.94	3.49	
	Power Factor		%	—	93	—	—	91	—	
	Indoor Noise (H / L / QLo)		dB-A	37 / 24 / 20			39 / 25 / 20			
			Power Level dB	53 / 40 / 36			55 / 41 / 36			
	Outdoor Noise (H / L)		dB-A	45 / -			46 / -			
			Power Level dB	60 / -			61 / -			
Heating	Capacity		kW	0.70	2.80	4.00	0.80	3.40	5.00	
			BTU/h	2390	9550	13600	2730	11600	17100	
			Kcal/h	600	2410	3440	690	2920	4300	
	Running Current		A	—	3.0	—	—	3.4	—	
	Input Power		W	160	635	1.02k	165	740	1.31k	
	COP		W/W	4.38	4.41	3.92	4.85	4.59	3.82	
			Kcal/hW	3.75	3.80	3.37	4.18	3.95	3.28	
	Power Factor		%	—	92	—	—	95	—	
	Indoor Noise (H / L / QLo)		dB-A	38 / 25 / 22			40 / 27 / 24			
			Power Level dB	54 / 41 / 38			56 / 43 / 40			
	Outdoor Noise (H / L)		dB-A	46 / -			47 / -			
			Power Level dB	61 / -			62 / -			
	Low Temp. : Capacity (kW) / I.Power (W) / COP			2.90 / 900 / 3.22			3.62 / 1.16k / 3.12			
Extr Low Temp. : Capacity (kW) / I.Power (W) / COP			2.35 / 930 / 2.53			2.88 / 1.19k / 2.42				
Max Current (A) / Max Input Power (W)			4.7 / 1.02k			5.8 / 1.31k				
Starting Current (A)			3.0			3.4				
Compressor		Type	Hermetic Motor			Hermetic Motor				
		Motor Type	Brushless (6-poles)			Brushless (6-poles)				
		Output Power	W	650			700			
Indoor Fan	Type		Cross-flow Fan			Cross-flow Fan				
	Material		ASG20K1			ASG20K1				
	Motor Type		Transistor (8-poles)			Transistor (8-poles)				
	Input Power		W	—			—			
	Output Power		W	40			40			
	Speed		QLo	Cool	rpm	590			630	
				Heat	rpm	680			770	
			Lo	Cool	rpm	670			740	
				Heat	rpm	730			830	
			Me	Cool	rpm	860			950	
				Heat	rpm	910			1030	
	Hi	Cool	rpm	1050			1170			
		Heat	rpm	1090			1240			
SHi		Cool	rpm	1110			1240			
		Heat	rpm	1150			1320			

MODEL		INDOOR	CS-E7JKEW-3, CS-XE7JKEW	CS-E9JKEW-3, CS-XE9JKEW	
		OUTDOOR	CU-E7JKE-3	CU-E9JKE-3	
Outdoor Fan	Type		Propeller Fan	Propeller Fan	
	Material		PP	PP	
	Motor Type		Induction (6-poles)	Induction (6-poles)	
	Input Power	W	62	65	
	Output Power	W	25	25	
	Speed	Hi	rpm	750	770
Moisture Removal		L/h (Pt/h)	1.3 (2.7)	1.5 (3.2)	
Indoor Airflow	QLo	Cool	m ³ /min (ft ³ /min)	5.6 (198)	4.9 (173)
		Heat	m ³ /min (ft ³ /min)	6.6 (233)	6.5 (230)
	Lo	Cool	m ³ /min (ft ³ /min)	6.5 (230)	6.1 (215)
		Heat	m ³ /min (ft ³ /min)	7.2 (254)	7.2 (254)
	Me	Cool	m ³ /min (ft ³ /min)	8.7 (307)	8.7 (307)
		Heat	m ³ /min (ft ³ /min)	9.3 (328)	9.6 (339)
	Hi	Cool	m ³ /min (ft ³ /min)	10.9 (385)	11.3 (400)
		Heat	m ³ /min (ft ³ /min)	11.4 (400)	11.9 (420)
	SHi	Cool	m ³ /min (ft ³ /min)	11.6 (410)	11.9 (420)
		Heat	m ³ /min (ft ³ /min)	12.0 (424)	13.1 (463)
Outdoor Airflow	Hi	Cool	m ³ /min (ft ³ /min)	28.8 (1020)	29.8 (1050)
		Heat	m ³ /min (ft ³ /min)	28.8 (1020)	29.8 (1050)
Refrigeration Cycle	Control Device		Check Valve & Capillary Tube	Check Valve & Capillary Tube	
	Refrigerant Oil	cm ³	RB68A or Freol Alpha 68M (320)	RB68A or Freol Alpha 68M (320)	
	Refrigerant Type	g (oz)	R410A, 780 (27.5)	R410A, 960 (33.9)	
Dimension	Height (I/D / O/D)	mm (inch)	290 (11-7/16) / 540 (21-9/32)	290 (11-7/16) / 540 (21-9/32)	
	Width (I/D / O/D)	mm (inch)	870 (34-9/32) / 780 (30-23/32)	870 (34-9/32) / 780 (30-23/32)	
	Depth (I/D / O/D)	mm (inch)	204 (8-1/16) / 289 (11-13/32)	204 (8-1/16) / 289 (11-13/32)	
Weight	Net (I/D / O/D)	kg (lb)	9 (20) / 33 (73)	9 (20) / 34 (75)	
Piping	Pipe Diameter (Liquid / Gas)	mm (inch)	6.35 (1/4) / 9.52 (3/8)	6.35 (1/4) / 9.52 (3/8)	
	Standard Length	m (ft)	5 (16.4)	5 (16.4)	
	Length Range (min - max)	m (ft)	3 (9.8) ~ 15 (49.2)	3 (9.8) ~ 15 (49.2)	
	I/D & O/D Height Different	m (ft)	15.0 (49.2)	15.0 (49.2)	
	Additional Gas Amount	g/m (oz/ft)	20 (0.2)	20 (0.2)	
	Length for Additional Gas	m (ft)	7.5 (24.6)	7.5 (24.6)	
Drain Hose	Inner Diameter	mm	16	16	
	Length	mm	650	650	
Indoor Heat Exchanger	Fin Material		Aluminium (Pre Coat)	Aluminium (Pre Coat)	
	Fin Type		Slit Fin	Slit Fin	
	Row x Stage x FPI		2 x 15 x 17	2 x 15 x 19	
	Size (W x H x L)	mm	610 x 315 x 25.4	610 x 315 x 25.4	
Outdoor Heat Exchanger	Fin Material		Aluminium	Aluminium	
	Fin Type		Corrugated Fin	Corrugated Fin	
	Row x Stage x FPI		2 x 24 x 17	2 x 24 x 17	
	Size (W x H x L)	mm	36.4 x 504 x 713 684	36.4 x 504 x 713 684	
Air Filter	Material		Polypropelene	Polypropelene	
	Type		One-touch	One-touch	
Power Supply			Outdoor Power Supply	Outdoor Power Supply	
Power Supply Cord		A	Nil	Nil	
Thermostat			Electronic Control	Electronic Control	
Protection Device			Electronic Control	Electronic Control	

MODEL		INDOOR	CS-E7JKEW-3, CS-XE7JKEW		CS-E9JKEW-3, CS-XE9JKEW	
		OUTDOOR	CU-E7JKE-3		CU-E9JKE-3	
			Dry Bulb	Wet Bulb	Dry Bulb	Wet Bulb
Indoor Operation Range	Cooling	Maximum	32	23	32	23
		Minimum	16	11	16	11
	Heating	Maximum	30	—	30	—
		Minimum	16	—	16	—
Outdoor Operation Range	Cooling	Maximum	43	26	43	26
		Minimum	16	11	16	11
	Heating	Maximum	24	18	24	18
		Minimum	-15	-16	-15	-16

1. Cooling capacities are based on indoor temperature of 27°C Dry Bulb (80.6°F Dry Bulb), 19.0°C Wet Bulb (66.2°F Wet Bulb) and outdoor air temperature of 35°C Dry Bulb (95°F Dry Bulb), 24°C Wet Bulb (75.2°F Wet Bulb)
2. Heating capacities are based on indoor temperature of 20°C Dry Bulb (68°F Dry Bulb) and outdoor air temperature of 7°C Dry Bulb (44.6°F Dry Bulb), 6°C Wet Bulb (42.8°F Wet Bulb)
3. Heating low temperature capacity, Input Power and COP measured at 230 V, indoor temperature 20°C, outdoor 2/1°C
4. Heating extreme low temperature capacity, Input Power and COP measured at 230 V, indoor temperature 20°C, outdoor -7/-8°C
5. Specifications are subjected to change without prior notice for further improvement.

MODEL		INDOOR		CS-E12JKEW-3, CS-XE12JKEW		
		OUTDOOR		CU-E12JKE-3		
Performance Test Condition				EUROVENT		
Power Supply		Phase, Hz		Single, 50		
		V		230		
				Min.	Mid.	Max.
Cooling	Capacity		kW	0.80	3.50	4.00
			BTU/h	2730	11900	13600
			Kcal/h	690	3010	3440
	Running Current		A	—	4.1	—
	Input Power		W	185	905	1.18k
	Annual Consumption		kWh	—	453	—
	EER		W/W	4.32	3.87	3.39
			Kcal/hW	3.73	3.33	2.92
	Power Factor		%	—	96	—
	Indoor Noise (H / L / QLo)		dB-A	42 / 28 / 20		
Power Level dB			58 / 44 / 36			
Outdoor Noise (H / L)		dB-A	48 / -			
		Power Level dB	63 / -			
Heating	Capacity		kW	0.80	4.40	6.70
			BTU/h	2730	15000	22800
			Kcal/h	690	3780	5760
	Running Current		A	—	5.1	—
	Input Power		W	175	1.09k	1.93k
	COP		W/W	4.57	4.04	3.47
			Kcal/hW	3.94	3.47	2.98
	Power Factor		%	—	93	—
	Indoor Noise (H / L / QLo)		dB-A	42 / 33 / 30		
			Power Level dB	58 / 49 / 46		
Outdoor Noise (H / L)		dB-A	50 / -			
		Power Level dB	65 / -			
Low Temp. : Capacity (kW) / I.Power (W) / COP				4.85 / 1.67k / 2.90		
Extr Low Temp. : Capacity (kW) / I.Power (W) / COP				3.75 / 1.68k / 2.23		
Max Current (A) / Max Input Power (W)				8.9 / 1.93k		
Starting Current (A)				5.1		
Compressor		Type		Hermetic Motor		
		Motor Type		Brushless (6-poles)		
		Output Power		W	700	
Indoor Fan	Type		Cross-flow Fan			
	Material		ASG20K1			
	Motor Type		Transistor (8-poles)			
	Input Power		W	—		
	Output Power		W	40		
	Speed	QLo	Cool	rpm	630	
			Heat	rpm	950	
		Lo	Cool	rpm	830	
			Heat	rpm	1010	
		Me	Cool	rpm	1040	
			Heat	rpm	1150	
		Hi	Cool	rpm	1260	
			Heat	rpm	1300	
SHi	Cool	rpm	1320			
	Heat	rpm	1340			

MODEL			INDOOR	CS-E12JKEW-3, CS-XE12JKEW
			OUTDOOR	CU-E12JKE-3
Outdoor Fan	Type			Propeller Fan
	Material			PP
	Motor Type			Induction (6-poles)
	Input Power		W	70
	Output Power		W	30
	Speed	Hi	rpm	830
Moisture Removal			L/h (Pt/h)	2.0 (4.2)
Indoor Airflow	QLo	Cool	m ³ /min (ft ³ /min)	4.9 (173)
		Heat	m ³ /min (ft ³ /min)	8.7 (307)
	Lo	Cool	m ³ /min (ft ³ /min)	7.2 (254)
		Heat	m ³ /min (ft ³ /min)	9.4 (332)
	Me	Cool	m ³ /min (ft ³ /min)	9.7 (343)
		Heat	m ³ /min (ft ³ /min)	11.0 (389)
	Hi	Cool	m ³ /min (ft ³ /min)	12.5 (440)
		Heat	m ³ /min (ft ³ /min)	12.8 (450)
	SHi	Cool	m ³ /min (ft ³ /min)	13.1 (463)
		Heat	m ³ /min (ft ³ /min)	13.3 (470)
Outdoor Airflow	Hi	Cool	m ³ /min (ft ³ /min)	31.0 (1090)
		Heat	m ³ /min (ft ³ /min)	31.0 (1090)
Refrigeration Cycle	Control Device			Check Valve & Capillary Tube
	Refrigerant Oil		cm ³	RB68A or Freol Alpha 68M (320)
	Refrigerant Type		g (oz)	R410A, 970 (34.2)
Dimension	Height (I/D / O/D)		mm (inch)	290 (11-7/16) / 540 (21-9/32)
	Width (I/D / O/D)		mm (inch)	870 (34-9/32) / 780 (30-23/32)
	Depth (I/D / O/D)		mm (inch)	204 (8-1/16) / 289 (11-13/32)
Weight	Net (I/D / O/D)		kg (lb)	9 (20) / 34 (75)
Piping	Pipe Diameter (Liquid / Gas)		mm (inch)	6.35 (1/4) / 9.52 (3/8)
	Standard Length		m (ft)	5 (16.4)
	Length Range (min - max)		m (ft)	3 (9.8) ~ 15 (49.2)
	I/D & O/D Height Different		m (ft)	15.0 (49.2)
	Additional Gas Amount		g/m (oz/ft)	20 (0.2)
	Length for Additional Gas		m (ft)	7.5 (24.6)
Drain Hose	Inner Diameter		mm	16
	Length		mm	650
Indoor Heat Exchanger	Fin Material			Aluminium (Pre Coat)
	Fin Type			Slit Fin
	Row x Stage x FPI			2 x 15 x 21
	Size (W x H x L)		mm	610 x 315 x 25.4
Outdoor Heat Exchanger	Fin Material			Aluminium
	Fin Type			Corrugated Fin
	Row x Stage x FPI			2 x 24 x 17
	Size (W x H x L)		mm	36.4 x 504 x 713 684
Air Filter	Material			Polypropelene
	Type			One-touch
Power Supply				Outdoor Power Supply
Power Supply Cord			A	Nil
Thermostat				Electronic Control
Protection Device				Electronic Control

MODEL		INDOOR	CS-E12JKEW-3, CS-XE12JKEW	
		OUTDOOR	CU-E12JKE-3	
			Dry Bulb	Wet Bulb
Indoor Operation Range	Cooling	Maximum	32	23
		Minimum	16	11
	Heating	Maximum	30	—
		Minimum	16	—
Outdoor Operation Range	Cooling	Maximum	43	26
		Minimum	16	11
	Heating	Maximum	24	18
		Minimum	-15	-16

1. Cooling capacities are based on indoor temperature of 27°C Dry Bulb (80.6°F Dry Bulb), 19.0°C Wet Bulb (66.2°F Wet Bulb) and outdoor air temperature of 35°C Dry Bulb (95°F Dry Bulb), 24°C Wet Bulb (75.2°F Wet Bulb)
2. Heating capacities are based on indoor temperature of 20°C Dry Bulb (68°F Dry Bulb) and outdoor air temperature of 7°C Dry Bulb (44.6°F Dry Bulb), 6°C Wet Bulb (42.8°F Wet Bulb)
3. Heating low temperature capacity, Input Power and COP measured at 230 V, indoor temperature 20°C, outdoor 2/1°C
4. Heating extreme low temperature capacity, Input Power and COP measured at 230 V, indoor temperature 20°C, outdoor -7/-8°C
5. Specifications are subjected to change without prior notice for further improvement.

MODEL		INDOOR		CS-E15JKEW, CS-XE15JKEW			
		OUTDOOR		CU-E15JKE-1			
Performance Test Condition				EUROVENT			
Power Supply		Phase, Hz		Single, 50			
		V		230			
				Min.	Mid.	Max.	
Cooling	Capacity		kW	0.80	4.20	5.00	
			BTU/h	2730	14300	17100	
			Kcal/h	690	3610	4300	
	Running Current		A	—	5.7	—	
	Input Power		W	195	1.26k	1.57k	
	Annual Consumption		kWh	—	630	—	
	EER		W/W	4.10	3.33	3.18	
			Kcal/hW	3.54	2.87	2.74	
	Power Factor		%	—	96	—	
	Indoor Noise (H / L / QLo)		dB-A	43 / 31 / 25			
			Power Level dB	59 / 47 / 41			
	Outdoor Noise (H / L)		dB-A	49 / -			
Power Level dB			64 / -				
Heating	Capacity		kW	0.80	5.30	6.80	
			BTU/h	2730	18100	23200	
			Kcal/h	690	4560	5850	
	Running Current		A	—	6.6	—	
	Input Power		W	185	1.44k	1.94k	
	COP		W/W	4.32	3.68	3.51	
			Kcal/hW	3.73	3.17	3.02	
	Power Factor		%	—	95	—	
	Indoor Noise (H / L / QLo)		dB-A	43 / 35 / 32			
			Power Level dB	59 / 51 / 48			
	Outdoor Noise (H / L)		dB-A	51 / -			
			Power Level dB	66 / -			
Low Temp. : Capacity (kW) / I.Power (W) / COP				4.92 / 1.72k / 2.86			
Extr Low Temp. : Capacity (kW) / I.Power (W) / COP				3.94 / 1.83k / 2.15			
Max Current (A) / Max Input Power (W)				9.0 / 1.94k			
Starting Current (A)				6.6			
Compressor		Type		Hermetic Motor			
		Motor Type		Brushless (6-poles)			
		Output Power		W	700		
Indoor Fan	Type		Cross-flow Fan				
	Material		ASG20K1				
	Motor Type		Transistor (8-poles)				
	Input Power		W	—			
	Output Power		W	40			
	Speed		QLo	Cool	rpm	730	
				Heat	rpm	1000	
	Speed		Lo	Cool	rpm	870	
				Heat	rpm	1080	
	Speed		Me	Cool	rpm	1070	
				Heat	rpm	1210	
	Speed		Hi	Cool	rpm	1270	
Heat				rpm	1350		
Speed		SHi	Cool	rpm	1340		
			Heat	rpm	1370		

MODEL		INDOOR		CS-E15JKEW, CS-XE15JKEW	
		OUTDOOR		CU-E15JKE-1	
Outdoor Fan	Type			Propeller Fan	
	Material			PP	
	Motor Type			Induction (6-poles)	
	Input Power	W		70	
	Output Power	W		30	
	Speed	Hi	rpm		850
Moisture Removal		L/h (Pt/h)		2.4 (5.1)	
Indoor Airflow		QLo	Cool	m ³ /min (ft ³ /min)	6.0 (212)
			Heat	m ³ /min (ft ³ /min)	9.2 (325)
		Lo	Cool	m ³ /min (ft ³ /min)	7.7 (272)
			Heat	m ³ /min (ft ³ /min)	10.2 (360)
		Me	Cool	m ³ /min (ft ³ /min)	10.1 (357)
			Heat	m ³ /min (ft ³ /min)	11.7 (413)
		Hi	Cool	m ³ /min (ft ³ /min)	12.5 (440)
			Heat	m ³ /min (ft ³ /min)	13.4 (475)
		SHi	Cool	m ³ /min (ft ³ /min)	13.3 (470)
			Heat	m ³ /min (ft ³ /min)	13.6 (480)
Outdoor Airflow		Hi	Cool	m ³ /min (ft ³ /min)	31.4 (1110)
			Heat	m ³ /min (ft ³ /min)	31.4 (1110)
Refrigeration Cycle		Control Device		Check Valve & Capillary Tube	
		Refrigerant Oil		cm ³	RB68A or Freol Alpha 68M (320)
		Refrigerant Type		g (oz)	R410A, 1010 (35.7)
Dimension		Height (I/D / O/D)		mm (inch)	
		Width (I/D / O/D)		mm (inch)	
		Depth (I/D / O/D)		mm (inch)	
Weight		Net (I/D / O/D)		kg (lb)	
				9 (20) / 34 (75)	
Piping	Pipe Diameter (Liquid / Gas)		mm (inch)		6.35 (1/4) / 12.7 (1/2)
	Standard Length		m (ft)		5 (16.4)
	Length Range (min - max)		m (ft)		3 (9.8) ~ 15 (49.2)
	I/D & O/D Height Different		m (ft)		15 (49.2)
	Additional Gas Amount		g/m (oz/ft)		20 (0.2)
	Length for Additional Gas		m (ft)		7.5 (24.6)
Drain Hose		Inner Diameter		mm	
		Length		mm	
				16	
				650	
Indoor Heat Exchanger		Fin Material		Aluminium (Pre Coat)	
		Fin Type		Slit Fin	
		Row x Stage x FPI		2 x 15 x 21	
		Size (W x H x L)		mm	
				610 x 315 x 25.4	
Outdoor Heat Exchanger		Fin Material		Aluminium	
		Fin Type		Corrugated Fin	
		Row x Stage x FPI		2 x 24 x 17	
		Size (W x H x L)		mm	
				36.4 x 504 x 713 684	
Air Filter		Material		Polypropelene	
		Type		One-touch	
Power Supply				Outdoor Power Supply	
Power Supply Cord		A		Nil	
Thermostat				Electronic Control	
Protection Device				Electronic Control	

MODEL		INDOOR	CS-E15JKEW, CS-XE15JKEW	
		OUTDOOR	CU-E15JKE-1	
			Dry Bulb	Wet Bulb
Indoor Operation Range	Cooling	Maximum	32	23
		Minimum	16	11
	Heating	Maximum	30	—
		Minimum	16	—
Outdoor Operation Range	Cooling	Maximum	43	26
		Minimum	16	11
	Heating	Maximum	24	18
		Minimum	-5	-6

1. Cooling capacities are based on indoor temperature of 27°C Dry Bulb (80.6°F Dry Bulb), 19.0°C Wet Bulb (66.2°F Wet Bulb) and outdoor air temperature of 35°C Dry Bulb (95°F Dry Bulb), 24°C Wet Bulb (75.2°F Wet Bulb)
2. Heating capacities are based on indoor temperature of 20°C Dry Bulb (68°F Dry Bulb) and outdoor air temperature of 7°C Dry Bulb (44.6°F Dry Bulb), 6°C Wet Bulb (42.8°F Wet Bulb)
3. Heating low temperature capacity, Input Power and COP measured at 230 V, indoor temperature 20°C, outdoor 2/1°C
4. Heating extreme low temperature capacity, Input Power and COP measured at 230 V, indoor temperature 20°C, outdoor -7/-8°C
5. Specifications are subjected to change without prior notice for further improvement.

• **Multi Split Combination Possibility:**

- A single outdoor unit enables air conditioning of up to two separate rooms for CU-2E15GBE, CU-2E18CBPG.
- A single outdoor unit enables air conditioning of up to three separate rooms for CU-3E18EBE, CU-3E23CBPG.
- A single outdoor unit enables air conditioning of up to four separate rooms for CU-4E27CBPG.

CONNECTABLE INDOOR UNIT			OUTDOOR UNIT													
			CU-2E15GBE		CU-2E18CBPG		CU-3E18EBE			CU-3E23CBPG			CU-4E27CBPG			
ROOM		Type	A	B	A	B	A	B	C	A	B	C	A	B	C	D
Wall	2.2kW	CS-E7JKEW CS-E7JKDW	●	●	●	●	●	●	●	●	●	●	●	●	●	●
	2.8kW	CS-E9JKEW CS-E9JKDW	●	●	●	●	●	●	●	●	●	●	●	●	●	●
	3.2kW	CS-E12JKEW CS-E12JKDW	●	●	●	●	●	●	●	●	●	●	●	●	●	●
	4.0kW	CS-E15JKEW CS-E15JKDW	—	—	—	—	●	●	●	●	●	●	●	●	●	●
	5.0kW	CS-E18JKEW CS-E18JKDW	—	—	—	—	●	●	●	●	●	●	●	●	●	●
Capacity range of connectable indoor units			From 4.4kW to 5.6kW		From 4.4kW to 6.4kW		From 5.0kW to 9.0kW			From 5.0kW to 10kW			From 5.0kW to 13.6kW			
Pipe length	1-room maximum pipe length (m)		20		20		25			25			25			
	Allowable elevation (m)		10		10		15			15			15			
	Total allowable pipe length (m)		30		30		50			50			70			
	Total pipe length for maximum chargeless length (m)		20		20		30			30			40			
	Additional gas amount over chargeless length (m)		20		20		20			20			20			

Note: "●": Available

Remarks for CU-2E15GBE / CU-2E18CBPG

- At least two indoor units must be connected.
- The total nominal cooling capacity of indoor units that will be connected to outdoor unit must be within connectable capacity range of indoor unit. (as shown in the table above)
Example: The indoor units' combination below is possible to connect to CU-2E15GBE. (Total nominal capacity of indoor units is between 4.4kW to 5.6kW)
 - Two CS-E7JKEW only (Total nominal cooling capacity is 4.4kW)
 - One CS-E7JKEW and one CS-E9JKEW. (Total nominal cooling capacity is 5.0kW)

Remarks for CU-3E18EBE / CU-3E23CBPG / CU-4E27CBPG

- At least two indoor units must be connected.
- The total nominal cooling capacity of indoor units that will be connected to outdoor unit must be within connectable capacity range of indoor unit. (as shown in the table above)
Example: The indoor units' combination below is possible to connect to CU-3E23CBPG. (Total nominal capacity of indoor units is between 5.0kW to 10.0kW)
 - Two CS-E9JKEW only (Total nominal cooling capacity is 5.6kW)
 - Three CS-E12JKEW. (Total nominal cooling capacity is 9.6kW)

Outdoor Unit	Indoor unit combination		Operation mode	Capacity (kW)		Power input (kW)		Current (A)
	Operation	Class (kW)		Rating	min - max	Rating	min - max	
CU-2E15GBE	One-room Operation	2.2	Cooling	2.20	1.1 - 2.9	0.52	0.22 - 0.75	2.45
			Heating	3.20	0.7 - 4.8	0.85	0.17 - 1.41	3.75
		2.8	Cooling	2.80	1.1 - 3.5	0.75	0.22 - 1.00	3.50
			Heating	4.00	0.7 - 5.5	1.15	0.17 - 1.70	5.10
		3.2	Cooling	3.20	1.1 - 4.0	0.92	0.22 - 1.22	4.30
			Heating	4.50	0.7 - 6.2	1.25	0.17 - 1.81	5.55
	Two-room Operation	2.2 + 2.2	Cooling	4.50	1.5 - 5.0	1.23	0.25 - 1.35	5.75
			Heating	5.40	1.1 - 7.0	1.17	0.21 - 1.67	5.20
		2.2 + 2.8	Cooling	4.50	1.5 - 5.2	1.25	0.25 - 1.53	5.80
			Heating	5.40	1.1 - 7.0	1.23	0.21 - 1.72	5.45
		2.2 + 3.2	Cooling	4.50	1.5 - 5.2	1.25	0.25 - 1.53	5.80
			Heating	5.40	1.1 - 7.0	1.23	0.21 - 1.72	5.45
		2.8 + 2.8	Cooling	4.50	1.5 - 5.2	1.23	0.25 - 1.52	5.75
			Heating	5.40	1.1 - 7.0	1.17	0.21 - 1.67	5.20

Outdoor Unit	Indoor unit combination		Operation mode	Capacity (kW)		Power input (kW)		Current (A)	
	Operation	Class (kW)		Rating	min - max	Rating	min - max		
CU-3E18EBE	One-room Operation	2.2	Cooling	2.20	1.8 - 2.9	0.50	0.34 - 0.81	2.5	
			Heating	3.20	1.2 - 4.1	0.74	0.30 - 1.23	3.7	
		2.8	Cooling	2.80	1.8 - 2.9	0.70	0.34 - 0.81	3.3	
			Heating	4.00	1.2 - 4.3	1.05	0.30 - 1.23	5.0	
		3.2	Cooling	3.20	1.8 - 3.8	0.80	0.34 - 1.36	3.7	
			Heating	4.50	1.2 - 5.8	1.23	0.30 - 2.10	5.8	
		4.0	Cooling	4.00	1.8 - 4.3	1.24	0.34 - 1.99	5.6	
			Heating	5.60	1.2 - 6.8	1.72	0.30 - 2.93	7.7	
		5.0	Cooling	5.00	1.9 - 5.7	1.55	0.34 - 2.13	6.8	
			Heating	6.80	1.2 - 6.9	2.10	0.30 - 2.52	9.2	
		Two-room Operation	2.2 + 2.2	Cooling	4.40	1.9 - 6.2	1.11	0.35 - 2.10	4.9
				Heating	5.80	1.4 - 7.0	1.45	0.31 - 2.55	6.4
			2.2 + 2.8	Cooling	5.00	1.9 - 6.2	1.41	0.35 - 2.10	6.2
				Heating	6.40	1.4 - 7.0	1.72	0.31 - 2.55	7.6
	2.2 + 3.2		Cooling	5.20	1.9 - 6.3	1.49	0.35 - 2.11	6.6	
			Heating	6.80	1.4 - 7.3	1.84	0.31 - 2.52	8.2	
	2.2 + 4.0		Cooling	5.20	1.9 - 6.4	1.45	0.35 - 2.11	6.4	
			Heating	6.80	1.4 - 7.3	1.80	0.31 - 2.51	7.9	
	2.2 + 5.0		Cooling	5.20	1.9 - 6.8	1.29	0.36 - 2.15	5.7	
			Heating	6.80	1.4 - 8.0	1.52	0.31 - 2.20	6.7	
	2.8 + 2.8		Cooling	5.20	1.9 - 6.2	1.54	0.35 - 2.10	6.8	
			Heating	6.80	1.4 - 7.0	1.93	0.31 - 2.55	8.5	
	2.8 + 3.2		Cooling	5.20	1.9 - 6.3	1.48	0.35 - 2.11	6.5	
			Heating	6.80	1.4 - 7.3	1.84	0.31 - 2.52	8.1	
	2.8 + 4.0		Cooling	5.20	1.9 - 6.4	1.44	0.35 - 2.11	6.4	
			Heating	6.80	1.4 - 7.3	1.80	0.31 - 2.51	8.0	
	2.8 + 5.0		Cooling	5.20	1.9 - 6.8	1.29	0.36 - 2.15	5.7	
			Heating	6.80	1.4 - 8.0	1.52	0.31 - 2.20	6.7	
	3.2 + 3.2		Cooling	5.20	1.9 - 6.4	1.45	0.35 - 2.12	6.4	
			Heating	6.80	1.4 - 7.5	1.75	0.31 - 2.49	7.7	
	3.2 + 4.0		Cooling	5.20	1.9 - 6.5	1.41	0.35 - 2.12	6.3	
			Heating	6.80	1.4 - 7.5	1.75	0.31 - 2.47	7.8	
	3.2 + 5.0		Cooling	5.20	1.9 - 6.9	1.25	0.36 - 2.15	5.5	
			Heating	6.80	1.4 - 8.0	1.50	0.31 - 2.18	6.6	
	4.0 + 4.0		Cooling	5.20	1.9 - 6.5	1.41	0.35 - 2.12	6.2	
			Heating	6.80	1.4 - 7.6	1.71	0.31 - 2.47	7.5	
	4.0 + 5.0		Cooling	5.20	1.9 - 6.9	1.25	0.36 - 2.16	5.5	
			Heating	6.80	1.4 - 8.0	1.50	0.31 - 2.17	6.6	
	Three-room Operation		2.2 + 2.2 + 2.2	Cooling	5.20	1.9 - 7.2	1.24	0.36 - 2.17	5.4
				Heating	6.78	1.5 - 8.1	1.53	0.32 - 2.12	6.7
			2.2 + 2.2 + 2.8	Cooling	5.20	1.9 - 7.2	1.24	0.36 - 2.17	5.4
				Heating	6.80	1.5 - 8.1	1.53	0.32 - 2.12	6.7
			2.2 + 2.2 + 3.2	Cooling	5.20	1.9 - 7.2	1.23	0.36 - 2.18	5.4
				Heating	6.80	1.4 - 8.3	1.49	0.32 - 2.11	6.5
			2.2 + 2.2 + 4.0	Cooling	5.20	1.8 - 7.3	1.23	0.36 - 2.18	5.4
				Heating	6.80	1.6 - 8.3	1.46	0.32 - 2.11	6.4
		2.2 + 2.8 + 2.8	Cooling	5.20	1.9 - 7.2	1.24	0.36 - 2.17	5.4	
			Heating	6.80	1.5 - 8.1	1.53	0.32 - 2.12	6.7	
		2.2 + 2.8 + 3.2	Cooling	5.20	1.9 - 7.2	1.23	0.36 - 2.18	5.4	
			Heating	6.80	1.4 - 8.3	1.49	0.32 - 2.11	6.5	
		2.2 + 2.8 + 4.0	Cooling	5.20	1.8 - 7.3	1.22	0.36 - 2.18	5.4	
			Heating	6.80	1.6 - 8.3	1.42	0.32 - 2.11	6.5	
2.2 + 3.2 + 3.2		Cooling	5.20	1.8 - 7.3	1.22	0.36 - 2.18	5.4		
		Heating	6.80	1.6 - 8.3	1.43	0.32 - 2.10	6.3		
2.8 + 2.8 + 2.8		Cooling	5.19	1.9 - 7.2	1.24	0.36 - 2.17	5.4		
		Heating	6.80	1.5 - 8.1	1.53	0.32 - 2.12	6.7		
2.8 + 2.8 + 3.2	Cooling	5.20	1.9 - 7.2	1.23	0.36 - 2.18	5.4			
	Heating	6.80	1.4 - 8.3	1.49	0.32 - 2.11	6.5			

Outdoor Unit	Indoor unit combination		Operation mode	Capacity (kW)		Power input (kW)		Current (A)	
	Operation	Class (kW)		Rating	min - max	Rating	min - max		
CU-3E23CBPG	One-room Operation	2.2	Cooling	2.20	1.9 - 2.7	0.45	0.38 - 0.62	2.25	
			Heating	3.20	1.7 - 4.1	0.84	0.37 - 1.31	3.85	
		2.8	Cooling	2.80	2.0 - 3.4	0.62	0.38 - 0.90	2.95	
			Heating	4.00	1.7 - 4.3	1.21	0.37 - 1.40	5.40	
		3.2	Cooling	3.20	2.0 - 3.9	0.72	0.38 - 1.09	3.40	
			Heating	4.50	1.7 - 5.7	1.31	0.37 - 1.91	5.85	
		4.0	Cooling	4.00	2.0 - 4.4	1.03	0.38 - 1.39	4.60	
			Heating	5.60	1.8 - 7.2	1.90	0.37 - 2.92	8.35	
		5.0	Cooling	5.00	2.1 - 5.2	1.61	0.40 - 1.80	7.15	
			Heating	7.10	2.1 - 7.3	2.84	0.43 - 2.89	12.40	
		Two-room Operation	2.2 + 2.2	Cooling	4.40	2.1 - 5.0	0.98	0.40 - 1.26	4.45
				Heating	6.30	1.8 - 8.6	1.41	0.40 - 2.57	6.25
			2.2 + 2.8	Cooling	5.00	2.1 - 6.1	1.23	0.40 - 1.88	5.50
				Heating	7.10	2.1 - 8.6	1.70	0.42 - 2.57	7.55
	2.2 + 3.2		Cooling	5.40	2.2 - 7.0	1.37	0.40 - 2.79	6.10	
			Heating	7.50	2.2 - 8.7	1.74	0.42 - 2.97	7.75	
	2.2 + 4.0		Cooling	6.20	2.2 - 7.1	1.82	0.40 - 2.79	8.00	
			Heating	8.20	2.4 - 8.7	2.01	0.44 - 2.97	8.85	
	2.2 + 5.0		Cooling	6.80	2.5 - 7.1	2.24	0.46 - 2.80	9.85	
			Heating	8.60	3.2 - 9.0	2.16	0.53 - 2.96	9.50	
	2.8 + 2.8		Cooling	5.60	2.2 - 6.9	1.55	0.40 - 2.78	6.85	
			Heating	7.70	2.3 - 8.7	1.93	0.44 - 3.04	8.45	
	2.8 + 3.2		Cooling	6.00	2.2 - 7.0	1.70	0.40 - 2.79	7.55	
			Heating	8.00	2.4 - 8.8	1.97	0.44 - 3.02	8.60	
	2.8 + 4.0		Cooling	6.80	2.2 - 7.1	2.39	0.46 - 2.79	10.50	
			Heating	8.60	2.1 - 9.0	2.175	0.53 - 3.03	9.55	
	2.8 + 5.0		Cooling	6.80	2.5 - 7.2	2.23	0.46 - 2.80	9.85	
			Heating	8.60	3.2 - 9.0	2.15	0.53 - 3.01	9.50	
	3.2 + 3.2		Cooling	6.40	2.2 - 7.3	1.86	0.40 - 2.81	8.15	
			Heating	8.40	2.5 - 9.0	2.05	0.47 - 2.97	9.05	
	3.2 + 4.0		Cooling	6.80	2.5 - 7.3	2.22	0.46 - 2.81	9.65	
			Heating	8.60	3.2 - 9.0	2.09	0.53 - 2.97	9.20	
	3.2 + 5.0		Cooling	6.80	2.6 - 7.4	2.12	0.46 - 2.82	9.30	
			Heating	8.60	3.2 - 9.0	2.08	0.53 - 2.95	9.15	
	4.0 + 4.0		Cooling	6.80	2.5 - 7.3	2.19	0.46 - 2.81	9.65	
			Heating	8.60	3.2 - 9.0	2.08	0.53 - 2.97	9.15	
	4.0 + 5.0		Cooling	6.80	2.7 - 7.4	2.11	0.48 - 2.82	9.30	
			Heating	8.60	3.2 - 9.1	2.07	0.53 - 2.95	9.15	
	5.0 + 5.0		Cooling	6.80	2.8 - 7.4	2.07	0.48 - 2.82	9.15	
			Heating	8.60	3.5 - 9.1	2.07	0.59 - 2.94	9.15	
	Three-room Operation	2.2 + 2.2 + 2.2	Cooling	6.60	2.2 - 7.7	1.85	0.41 - 2.45	8.10	
			Heating	8.53	3.1 - 8.9	1.94	0.50 - 2.80	8.50	
		2.2 + 2.2 + 2.8	Cooling	6.80	2.5 - 8.1	1.98	0.46 - 2.82	8.70	
			Heating	8.60	3.2 - 8.9	1.98	0.51 - 2.80	8.70	
		2.2 + 2.2 + 3.2	Cooling	6.80	2.5 - 8.1	1.99	0.46 - 2.79	8.80	
			Heating	8.60	3.2 - 9.0	1.96	0.51 - 2.78	8.60	
		2.2 + 2.2 + 4.0	Cooling	6.80	2.6 - 8.2	1.97	0.46 - 2.79	8.60	
			Heating	8.60	3.2 - 8.8	1.94	0.51 - 2.76	8.50	
		2.2 + 2.2 + 5.0	Cooling	6.80	2.8 - 8.3	1.96	0.49 - 2.79	8.60	
			Heating	8.60	3.2 - 8.8	1.92	0.51 - 2.76	8.45	
2.2 + 2.8 + 2.8		Cooling	6.80	2.5 - 8.1	1.95	0.46 - 2.78	8.50		
		Heating	8.60	3.2 - 9.0	1.93	0.51 - 2.73	8.45		
2.2 + 2.8 + 3.2		Cooling	6.80	2.6 - 8.1	1.98	0.46 - 2.79	8.70		
		Heating	8.60	3.2 - 8.8	1.93	0.51 - 2.76	8.45		
2.2 + 2.8 + 4.0		Cooling	6.80	2.7 - 8.2	1.96	0.49 - 2.79	8.60		
		Heating	8.60	3.2 - 9.0	1.91	0.51 - 2.76	8.35		
2.2 + 2.8 + 5.0		Cooling	6.80	2.8 - 8.3	1.95	0.49 - 2.79	8.50		
		Heating	8.60	3.5 - 9.0	1.92	0.56 - 2.73	8.45		
2.2 + 3.2 + 3.2		Cooling	6.80	2.7 - 8.3	1.97	0.46 - 2.80	8.60		
		Heating	8.60	3.2 - 9.1	1.91	0.50 - 2.71	8.35		
2.2 + 3.2 + 4.0		Cooling	6.80	2.8 - 8.3	1.95	0.49 - 2.80	8.50		
		Heating	8.60	3.2 - 9.0	1.89	0.50 - 2.71	8.25		
2.8 + 2.8 + 2.8		Cooling	6.78	2.6 - 8.1	1.94	0.46 - 2.82	8.50		
		Heating	8.58	3.2 - 9.0	1.91	0.51 - 2.76	8.35		

Outdoor Unit	Indoor unit combination		Operation mode	Capacity (kW)		Power input (kW)		Current (A)		
	Operation	Class (kW)		Rating	min - max	Rating	min - max			
CU-3E23CBPG	Three-room Operation	2.8 + 2.8 + 3.2	Cooling	6.80	2.7 - 8.2	1.96	0.49 - 2.79	8.60		
			Heating	8.60	3.2 - 9.0	1.92	0.51 - 2.76	8.45		
		2.8 + 2.8 + 4.0	Cooling	6.80	2.8 - 8.2	1.95	0.49 - 2.79	8.50		
			Heating	8.60	3.3 - 9.0	1.90	0.53 - 2.76	8.35		
		2.8 + 3.2 + 3.2	Cooling	6.80	2.7 - 8.3	1.96	0.49 - 2.80	8.60		
			Heating	8.60	3.2 - 9.0	1.90	0.50 - 2.71	8.35		
		2.8 + 3.2 + 4.0	Cooling	6.80	2.8 - 8.4	1.95	0.49 - 2.80	8.50		
			Heating	8.60	3.5 - 9.1	1.88	0.56 - 2.71	8.30		
		3.2 + 3.2 + 3.2	Cooling	6.78	2.8 - 8.5	1.96	0.49 - 2.80	8.60		
			Heating	8.58	3.3 - 9.1	1.85	0.52 - 2.67	8.10		
		CU-4E27CBPG	One-room Operation	2.2	Cooling	2.20	1.9 - 2.7	0.45	0.38 - 0.62	2.25
					Heating	3.20	1.7 - 4.7	0.84	0.37 - 1.83	3.85
2.8	Cooling			2.80	2.0 - 3.4	0.62	0.38 - 0.90	2.95		
	Heating			4.00	1.7 - 4.8	1.21	0.37 - 1.90	5.40		
3.2	Cooling			3.20	2.0 - 3.9	0.72	0.38 - 1.09	3.40		
	Heating			4.50	1.7 - 5.8	1.31	0.37 - 2.29	5.85		
4.0	Cooling			4.00	2.0 - 4.4	1.03	0.38 - 1.39	4.60		
	Heating			5.60	1.8 - 7.2	1.90	0.37 - 3.56	8.35		
5.0	Cooling			5.00	2.1 - 5.2	1.61	0.40 - 1.80	7.15		
	Heating			7.10	2.1 - 7.3	2.84	0.43 - 3.56	12.40		
Two-room Operation	2.2 + 2.2			Cooling	4.40	2.1 - 5.0	0.98	0.40 - 1.26	4.45	
				Heating	6.40	1.8 - 9.4	1.48	0.40 - 3.55	6.50	
	2.2 + 2.8			Cooling	5.00	2.1 - 6.1	1.23	0.40 - 1.88	5.50	
				Heating	7.10	2.1 - 9.4	1.70	0.42 - 3.51	7.55	
	2.2 + 3.2			Cooling	5.40	2.2 - 7.0	1.37	0.40 - 2.79	6.10	
			Heating	7.50	2.2 - 9.8	1.74	0.42 - 3.49	7.65		
	2.2 + 4.0		Cooling	6.20	2.2 - 7.1	1.82	0.40 - 2.79	8.00		
			Heating	8.30	2.4 - 9.8	2.06	0.44 - 3.44	9.05		
	2.2 + 5.0		Cooling	7.00	2.5 - 7.2	2.50	0.46 - 2.80	11.00		
			Heating	8.80	3.2 - 9.9	2.26	0.53 - 3.40	9.90		
	2.8 + 2.8		Cooling	5.60	2.2 - 6.9	1.55	0.40 - 2.78	6.85		
			Heating	7.70	2.3 - 9.4	2.02	0.44 - 3.48	8.85		
	2.8 + 3.2		Cooling	6.00	2.2 - 7.0	1.70	0.40 - 2.79	7.55		
			Heating	8.10	2.4 - 9.8	1.98	0.44 - 3.46	8.70		
	2.8 + 4.0		Cooling	6.80	2.2 - 7.1	2.28	0.40 - 2.79	10.00		
Heating			8.60	2.1 - 9.8	2.175	0.53 - 3.39	9.65			
2.8 + 5.0	Cooling		7.10	2.5 - 7.2	2.61	0.46 - 2.80	11.50			
	Heating		9.00	3.2 - 9.9	2.39	0.53 - 3.37	10.50			
3.2 + 3.2	Cooling		6.40	2.2 - 7.3	1.86	0.40 - 2.81	8.15			
	Heating		8.50	2.5 - 10.1	2.11	0.47 - 3.39	9.30			
3.2 + 4.0	Cooling	7.00	2.5 - 7.3	2.41	0.46 - 2.81	10.60				
	Heating	8.80	3.2 - 10.1	2.23	0.53 - 3.34	9.85				
3.2 + 5.0	Cooling	7.40	2.6 - 7.4	2.82	0.46 - 2.88	12.30				
	Heating	9.20	3.2 - 10.1	2.39	0.53 - 3.30	10.50				
4.0 + 4.0	Cooling	7.20	2.5 - 7.3	2.62	0.46 - 2.81	11.50				
	Heating	9.10	3.2 - 10.1	2.36	0.53 - 3.32	10.30				
4.0 + 5.0	Cooling	7.30	2.7 - 7.4	2.67	0.48 - 2.82	11.70				
	Heating	9.40	3.2 - 10.2	2.48	0.53 - 3.30	10.90				
5.0 + 5.0	Cooling	7.50	2.8 - 7.6	2.86	0.48 - 2.87	12.50				
	Heating	9.40	3.5 - 10.2	2.47	0.59 - 3.29	10.90				
Three-room Operation	2.2 + 2.2 + 2.2	Cooling	6.60	2.2 - 7.8	1.66	0.41 - 2.49	7.40			
		Heating	8.61	3.1 - 10.4	1.99	0.50 - 3.25	8.80			
	2.2 + 2.2 + 2.8	Cooling	7.00	2.5 - 8.1	1.89	0.46 - 2.85	8.25			
		Heating	8.80	3.2 - 10.4	2.01	0.51 - 3.22	8.85			
	2.2 + 2.2 + 3.2	Cooling	7.30	2.5 - 8.2	1.98	0.46 - 2.79	8.70			
		Heating	8.90	3.2 - 10.4	2.03	0.51 - 3.22	8.95			
	2.2 + 2.2 + 4.0	Cooling	7.80	2.6 - 8.2	2.33	0.46 - 2.83	10.30			
		Heating	9.20	3.2 - 10.4	2.15	0.51 - 3.18	9.50			
	2.2 + 2.2 + 5.0	Cooling	8.00	2.8 - 8.3	2.46	0.49 - 2.82	10.80			
		Heating	9.40	3.2 - 10.4	2.12	0.51 - 3.18	9.30			
	2.2 + 2.8 + 2.8	Cooling	7.40	2.5 - 8.1	2.14	0.46 - 2.79	9.40			
		Heating	9.00	3.2 - 10.4	2.09	0.51 - 3.19	9.20			
	2.2 + 2.8 + 3.2	Cooling	7.60	2.6 - 8.2	2.24	0.46 - 2.84	9.85			
		Heating	9.20	3.2 - 10.4	2.11	0.51 - 3.18	9.30			
	2.2 + 2.8 + 4.0	Cooling	8.00	2.7 - 8.2	2.51	0.49 - 2.80	11.00			
Heating		9.40	3.2 - 10.4	2.16	0.51 - 3.14	9.50				

Outdoor Unit	Indoor unit combination		Operation mode	Capacity (kW)		Power input (kW)		Current (A)
	Operation	Class (kW)		Rating	min - max	Rating	min - max	
CU-4E27CBPG	Three-room Operation	2.2 + 2.8 + 5.0	Cooling	8.00	2.8 - 8.3	2.46	0.49 - 2.80	10.80
			Heating	9.40	3.5 - 10.4	2.08	0.56 - 3.15	9.15
		2.2 + 3.2 + 3.2	Cooling	7.90	2.7 - 8.3	2.29	0.46 - 2.81	10.10
			Heating	9.30	3.2 - 10.5	2.13	0.50 - 3.18	9.40
		2.2 + 3.2 + 4.0	Cooling	8.00	2.8 - 8.4	2.38	0.49 - 2.84	10.40
			Heating	9.40	3.2 - 10.5	2.15	0.50 - 3.14	9.50
		2.2 + 3.2 + 5.0	Cooling	8.00	2.8 - 8.3	2.47	0.49 - 2.84	10.90
			Heating	9.40	3.7 - 10.5	2.17	0.62 - 3.14	9.55
		2.2 + 4.0 + 4.0	Cooling	8.00	2.8 - 8.4	2.38	0.49 - 2.81	10.40
			Heating	9.40	3.6 - 10.5	2.11	0.62 - 3.11	9.30
		2.2 + 4.0 + 5.0	Cooling	8.00	2.8 - 8.3	2.47	0.49 - 2.81	10.90
			Heating	9.40	3.9 - 10.5	2.12	0.66 - 3.11	9.30
		2.2 + 5.0 + 5.0	Cooling	8.00	2.9 - 8.4	2.43	0.49 - 2.83	10.70
			Heating	9.40	4.1 - 10.5	2.17	0.70 - 3.12	9.55
		2.8 + 2.8 + 2.8	Cooling	7.80	2.6 - 8.1	2.45	0.46 - 2.82	10.80
			Heating	9.24	3.2 - 10.4	2.17	0.51 - 3.16	9.55
		2.8 + 2.8 + 3.2	Cooling	8.00	2.7 - 8.2	2.51	0.49 - 2.81	11.00
			Heating	9.40	3.2 - 10.4	2.19	0.51 - 3.15	9.65
		2.8 + 2.8 + 4.0	Cooling	8.00	2.8 - 8.2	2.51	0.49 - 2.79	11.00
			Heating	9.40	3.3 - 10.4	2.14	0.53 - 3.13	9.40
		2.8 + 2.8 + 5.0	Cooling	8.00	2.8 - 8.3	2.46	0.49 - 2.79	10.80
			Heating	9.40	3.8 - 10.4	2.10	0.64 - 3.12	9.20
		2.8 + 3.2 + 3.2	Cooling	8.00	2.7 - 8.4	2.38	0.49 - 2.85	10.40
			Heating	9.40	3.2 - 10.5	2.17	0.50 - 3.15	9.55
		2.8 + 3.2 + 4.0	Cooling	8.00	2.8 - 8.4	2.38	0.49 - 2.82	10.40
			Heating	9.40	3.5 - 10.5	2.13	0.56 - 3.12	9.40
		2.8 + 3.2 + 5.0	Cooling	8.00	2.8 - 8.4	2.34	0.49 - 2.83	10.30
			Heating	9.40	3.9 - 10.5	2.15	0.66 - 3.12	9.50
		2.8 + 4.0 + 4.0	Cooling	8.00	2.8 - 8.4	2.38	0.49 - 2.80	10.40
			Heating	9.40	3.8 - 10.5	2.06	0.64 - 3.08	9.05
		2.8 + 4.0 + 5.0	Cooling	8.00	2.8 - 8.4	2.34	0.49 - 2.80	10.30
			Heating	9.40	4.0 - 10.5	2.10	0.68 - 3.08	9.20
	2.8 + 5.0 + 5.0	Cooling	8.00	2.9 - 8.5	2.34	0.52 - 2.80	10.30	
		Heating	9.40	4.2 - 10.5	2.14	0.70 - 3.08	9.40	
	3.2 + 3.2 + 3.2	Cooling	7.98	2.8 - 8.5	2.30	0.49 - 2.83	10.10	
		Heating	9.39	3.3 - 10.5	2.16	0.52 - 3.18	9.50	
	3.2 + 3.2 + 4.0	Cooling	8.00	2.8 - 8.4	2.39	0.49 - 2.80	10.50	
		Heating	9.40	3.7 - 10.5	2.14	0.62 - 3.15	9.40	
	3.2 + 3.2 + 5.0	Cooling	8.00	2.8 - 8.4	2.39	0.49 - 2.83	10.50	
		Heating	9.40	4.0 - 10.5	2.13	0.68 - 3.12	9.40	
	3.2 + 4.0 + 4.0	Cooling	8.00	2.8 - 8.4	2.39	0.49 - 2.82	10.50	
		Heating	9.40	3.9 - 10.5	2.12	0.66 - 3.12	9.30	
	3.2 + 4.0 + 5.0	Cooling	8.00	2.9 - 8.4	2.35	0.49 - 2.82	10.30	
		Heating	9.40	4.1 - 10.5	2.10	0.70 - 3.10	9.20	
	3.2 + 5.0 + 5.0	Cooling	8.00	2.9 - 8.5	2.35	0.52 - 2.81	10.30	
		Heating	9.40	4.2 - 10.5	2.06	0.70 - 3.08	9.05	
	4.0 + 4.0 + 4.0	Cooling	7.98	2.9 - 8.4	2.39	0.49 - 2.84	10.50	
		Heating	9.39	4.0 - 10.5	2.10	0.68 - 3.08	9.20	
	4.0 + 4.0 + 5.0	Cooling	8.00	2.9 - 8.4	2.39	0.52 - 2.81	10.50	
		Heating	9.40	4.2 - 10.5	2.08	0.70 - 3.08	9.15	
	Four-room Operation	2.2 + 2.2 + 2.2 + 2.2	Cooling	8.00	2.7 - 8.8	2.15	0.49 - 2.84	9.50
			Heating	9.40	3.2 - 10.5	2.08	0.55 - 3.14	9.15
2.2 + 2.2 + 2.2 + 2.8		Cooling	8.00	2.8 - 8.8	2.14	0.49 - 2.88	9.40	
		Heating	9.40	3.2 - 10.5	2.06	0.55 - 3.12	9.05	
2.2 + 2.2 + 2.2 + 3.2		Cooling	8.00	2.8 - 8.9	2.13	0.49 - 2.88	9.40	
		Heating	9.40	3.4 - 10.5	2.12	0.59 - 3.18	9.30	
2.2 + 2.2 + 2.2 + 4.0		Cooling	8.00	2.8 - 8.9	2.11	0.49 - 2.87	9.30	
		Heating	9.40	3.8 - 10.5	2.09	0.64 - 3.14	9.20	
2.2 + 2.2 + 2.2 + 5.0		Cooling	8.00	2.8 - 8.9	2.11	0.49 - 2.84	9.30	
		Heating	9.40	4.0 - 10.5	2.12	0.68 - 3.11	9.30	
2.2 + 2.2 + 2.8 + 2.8		Cooling	8.00	2.8 - 8.8	2.13	0.49 - 2.87	9.40	
		Heating	9.40	3.5 - 10.5	2.05	0.61 - 3.11	9.05	
2.2 + 2.2 + 2.8 + 3.2		Cooling	8.00	2.8 - 8.9	2.12	0.49 - 2.87	9.30	
		Heating	9.40	3.7 - 10.5	2.10	0.62 - 3.16	9.20	
2.2 + 2.2 + 2.8 + 4.0		Cooling	8.00	2.8 - 8.9	2.09	0.49 - 2.84	9.20	
		Heating	9.40	3.9 - 10.5	2.07	0.66 - 3.11	9.10	

Outdoor Unit	Indoor unit combination		Operation mode	Capacity (kW)		Power input (kW)		Current (A)
	Operation	Class (kW)		Rating	min - max	Rating	min - max	
CU-4E27CBPG	Four-room Operation	2.2 + 2.2 + 2.8 + 5.0	Cooling	8.00	2.9 - 8.9	2.11	0.52 - 2.88	9.30
			Heating	9.40	4.1 - 10.5	2.09	0.70 - 3.10	9.20
		2.2 + 2.2 + 3.2 + 3.2	Cooling	8.00	2.8 - 8.9	2.09	0.50 - 2.87	9.20
			Heating	9.40	3.8 - 10.5	2.11	0.64 - 3.19	9.30
		2.2 + 2.2 + 3.2 + 4.0	Cooling	8.00	2.8 - 8.9	2.08	0.50 - 2.84	9.15
			Heating	9.40	4.0 - 10.5	2.08	0.68 - 3.15	9.15
		2.2 + 2.2 + 3.2 + 5.0	Cooling	8.00	2.9 - 9.0	2.04	0.52 - 2.86	8.95
			Heating	9.40	4.1 - 10.5	2.11	0.70 - 3.08	9.30
		2.2 + 2.2 + 4.0 + 4.0	Cooling	8.00	2.9 - 9.0	2.06	0.52 - 2.85	9.05
			Heating	9.40	4.1 - 10.5	2.05	0.70 - 3.11	9.05
		2.2 + 2.2 + 4.0 + 5.0	Cooling	8.00	2.9 - 9.0	2.02	0.52 - 2.88	8.85
			Heating	9.40	4.2 - 10.5	2.08	0.70 - 3.06	9.15
		2.2 + 2.8 + 2.8 + 2.8	Cooling	8.00	2.8 - 8.8	2.12	0.49 - 2.85	9.30
			Heating	9.40	3.8 - 10.5	2.04	0.64 - 3.08	8.95
		2.2 + 2.8 + 2.8 + 3.2	Cooling	8.00	2.8 - 8.9	2.10	0.49 - 2.85	9.20
			Heating	9.40	3.9 - 10.5	2.08	0.66 - 3.13	9.15
		2.2 + 2.8 + 2.8 + 4.0	Cooling	8.00	2.8 - 8.9	2.13	0.49 - 2.86	9.40
			Heating	9.40	4.0 - 10.5	2.05	0.68 - 3.08	9.05
		2.2 + 2.8 + 2.8 + 5.0	Cooling	8.00	2.9 - 8.9	2.11	0.52 - 2.86	9.30
			Heating	9.40	4.2 - 10.5	2.08	0.70 - 3.08	9.15
		2.2 + 2.8 + 3.2 + 3.2	Cooling	8.00	2.8 - 8.9	2.13	0.50 - 2.85	9.40
			Heating	9.40	4.0 - 10.5	2.09	0.68 - 3.18	9.20
		2.2 + 2.8 + 3.2 + 4.0	Cooling	8.00	2.9 - 9.0	2.07	0.52 - 2.86	9.15
			Heating	9.40	4.1 - 10.5	2.06	0.70 - 3.12	9.05
		2.2 + 2.8 + 3.2 + 5.0	Cooling	8.00	2.9 - 9.0	2.03	0.52 - 2.84	8.95
			Heating	9.40	4.2 - 10.5	2.09	0.70 - 3.08	9.20
		2.2 + 2.8 + 4.0 + 4.0	Cooling	8.00	2.9 - 9.0	2.04	0.52 - 2.87	8.95
			Heating	9.40	4.2 - 10.5	2.03	0.70 - 3.08	8.95
		2.2 + 3.2 + 3.2 + 3.2	Cooling	8.00	2.8 - 9.1	2.04	0.50 - 2.87	8.95
			Heating	9.40	4.0 - 10.6	2.11	0.68 - 3.12	9.30
		2.2 + 3.2 + 3.2 + 4.0	Cooling	8.00	2.9 - 9.1	2.02	0.52 - 2.84	8.85
			Heating	9.40	4.1 - 10.6	2.08	0.70 - 3.08	9.15
		2.2 + 3.2 + 3.2 + 5.0	Cooling	8.00	3.0 - 9.2	2.00	0.53 - 2.87	8.80
			Heating	9.40	4.2 - 10.6	2.11	0.70 - 3.06	9.30
		2.2 + 3.2 + 4.0 + 4.0	Cooling	8.00	2.9 - 9.1	2.09	0.52 - 2.86	9.20
			Heating	9.40	4.2 - 10.6	2.06	0.70 - 3.06	9.05
		2.8 + 2.8 + 2.8 + 2.8	Cooling	8.00	2.8 - 8.8	2.11	0.49 - 2.84	9.30
			Heating	9.40	3.9 - 10.5	2.03	0.66 - 3.08	8.95
		2.8 + 2.8 + 2.8 + 3.2	Cooling	8.00	2.8 - 8.9	2.09	0.49 - 2.87	9.20
			Heating	9.40	4.0 - 10.5	2.06	0.68 - 3.10	9.05
		2.8 + 2.8 + 2.8 + 4.0	Cooling	8.00	2.9 - 8.9	2.12	0.52 - 2.85	9.30
			Heating	9.40	4.1 - 10.5	2.04	0.70 - 3.07	8.95
		2.8 + 2.8 + 2.8 + 5.0	Cooling	8.00	2.9 - 8.9	2.11	0.52 - 2.85	9.30
			Heating	9.40	4.2 - 10.5	2.07	0.70 - 3.07	9.15
		2.8 + 2.8 + 3.2 + 3.2	Cooling	8.00	2.9 - 9.0	2.08	0.50 - 2.87	9.15
			Heating	9.40	4.0 - 10.5	2.07	0.68 - 3.14	9.15
		2.8 + 2.8 + 3.2 + 4.0	Cooling	8.00	2.9 - 9.0	2.05	0.52 - 2.88	9.05
			Heating	9.40	4.2 - 10.5	2.04	0.70 - 3.08	8.95
2.8 + 2.8 + 4.0 + 4.0	Cooling	8.00	3.0 - 9.0	2.04	0.52 - 2.86	8.95		
	Heating	9.40	4.2 - 10.5	2.02	0.70 - 3.07	8.85		
2.8 + 3.2 + 3.2 + 3.2	Cooling	8.00	2.9 - 9.1	2.03	0.52 - 2.86	8.95		
	Heating	9.40	4.1 - 10.6	2.09	0.70 - 3.10	9.20		
2.8 + 3.2 + 3.2 + 4.0	Cooling	8.00	2.9 - 9.1	2.01	0.52 - 2.88	8.85		
	Heating	9.40	4.2 - 10.6	2.07	0.70 - 3.08	9.15		
3.2 + 3.2 + 3.2 + 3.2	Cooling	8.00	2.9 - 9.2	2.00	0.53 - 2.85	8.80		
	Heating	9.40	4.2 - 10.6	2.11	0.70 - 3.08	9.30		
3.2 + 3.2 + 3.2 + 4.0	Cooling	8.00	3.0 - 9.2	1.98	0.53 - 2.87	8.70		
	Heating	9.40	4.2 - 10.6	2.08	0.70 - 3.06	9.10		

3 Features

- **Inverter Technology**
 - Wider output power range
 - Energy saving
 - Quick Cooling
 - Quick Heating
 - More precise temperature control
- **E-ion Air Purifying System with Patrol Sensor**
 - Active e-ions are released to catch dust particles and bring them back the large positively charged filter
- **Environment Protection**
 - Non-ozone depletion substances refrigerant (R410A)
- **Long Installation Piping**
 - Long piping up to 15 meters
- **Easy to use remote control**
- **Quality Improvement**
 - Random auto restart after power failure for safety restart operation
 - Gas leakage protection
 - Prevent compressor reverse cycle
 - Inner protector to protect Compressor
 - Noise prevention during soft dry operation
- **Operation Improvement**
 - Quiet mode to reduce the indoor unit operating sound
 - Powerful mode to reach the desired room temperature quickly
 - 24-hour timer setting
- **Serviceability Improvement**
 - Breakdown Self Diagnosis function

4 Location of Controls and Components

4.1. Indoor Unit

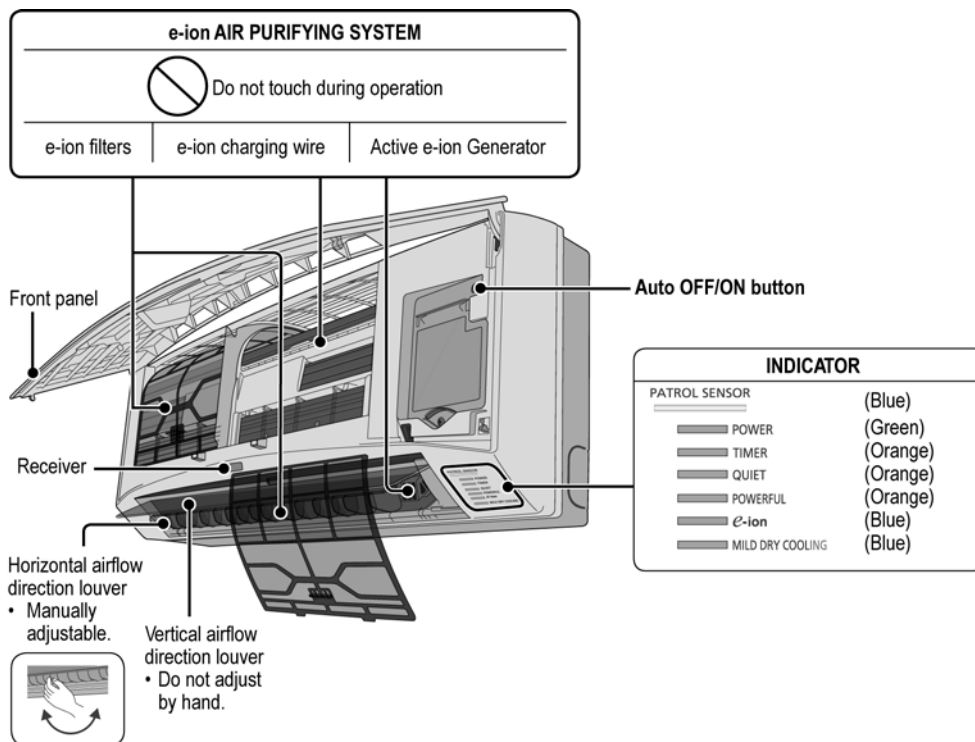

4.2. Outdoor Unit

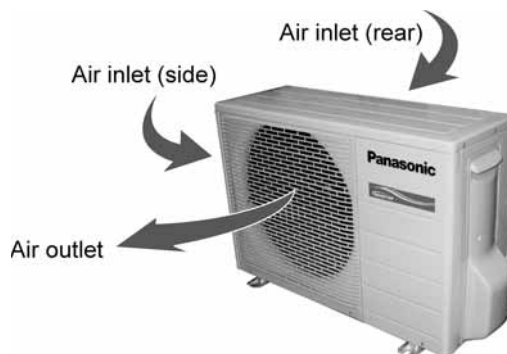

4.3. Remote Control

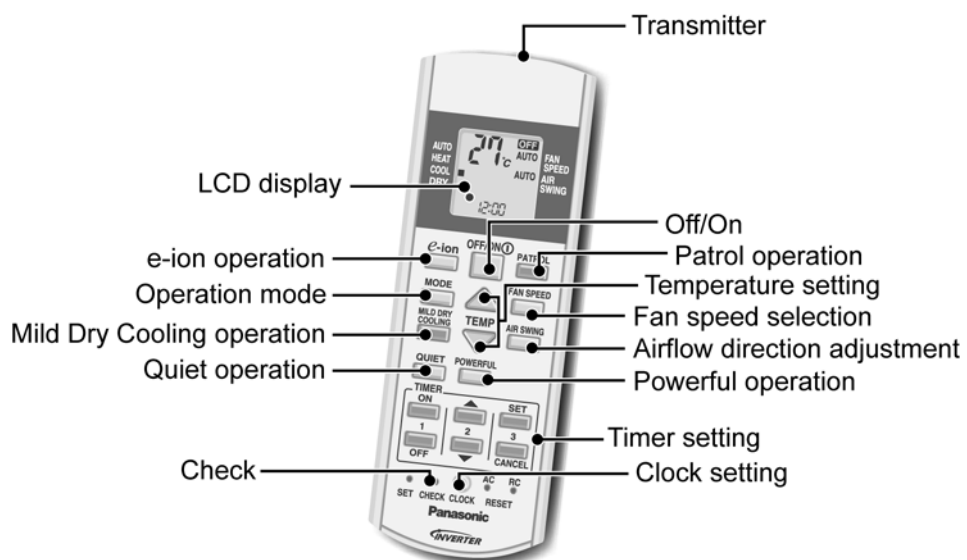

5 Dimensions

5.1. Indoor Unit

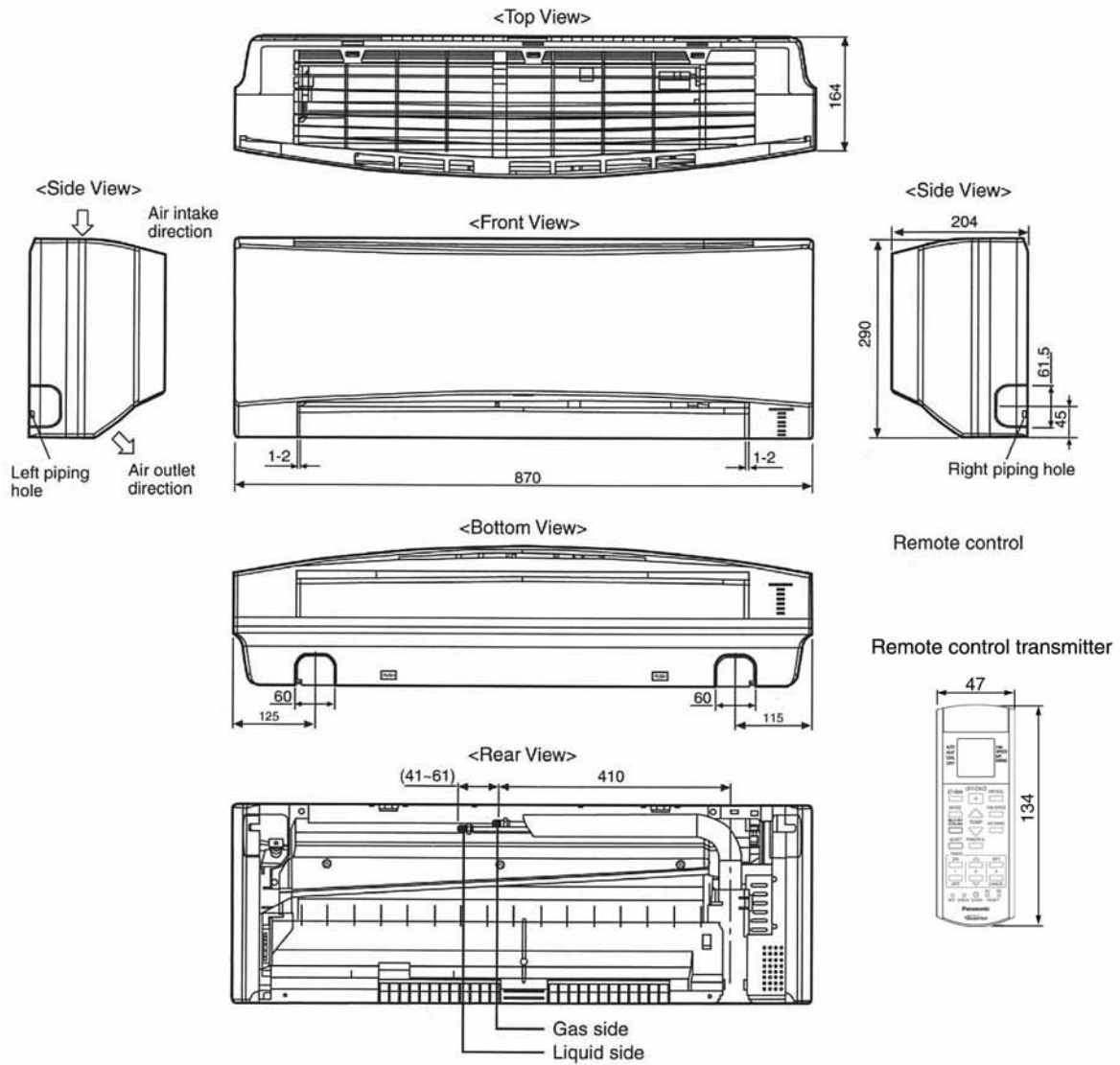

Relative position between the indoor unit and the installation plate <Front View>

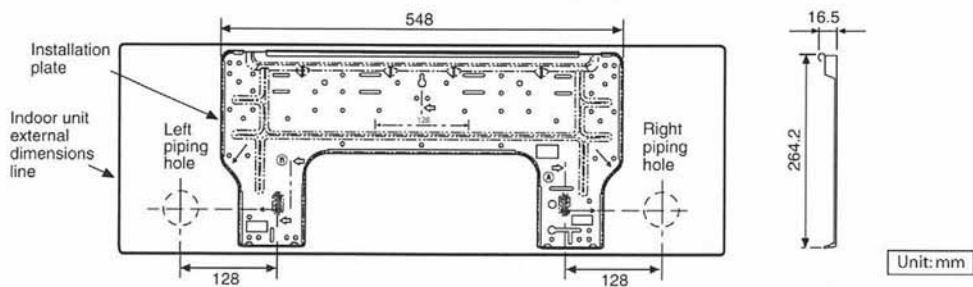

5.2. Outdoor Unit

5.2.1. CU-E7JKE CU-E9JKE CU-E12JKE CU-E15JKE-1 CU-E7JKE-3 CU-E9JKE-3 CU-E12JKE-3

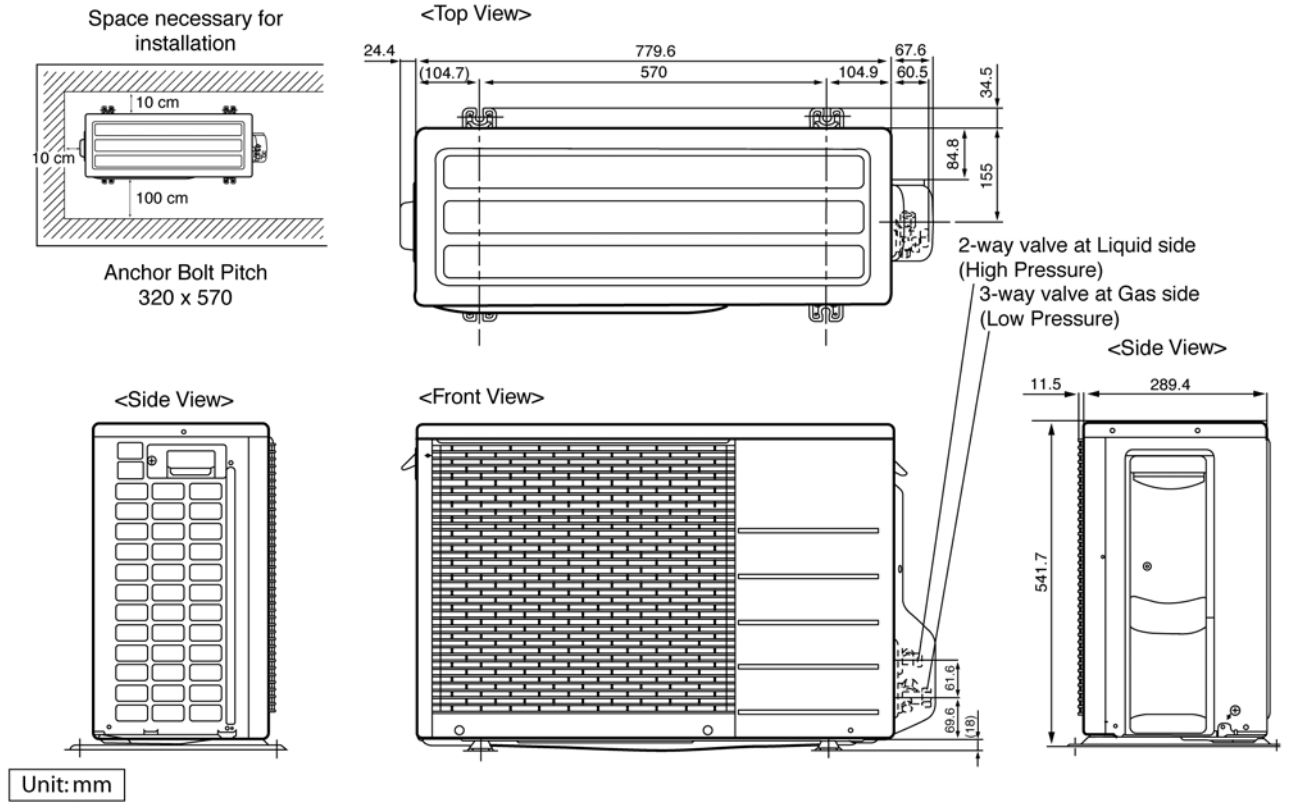

5.2.2. CU-E15JKE

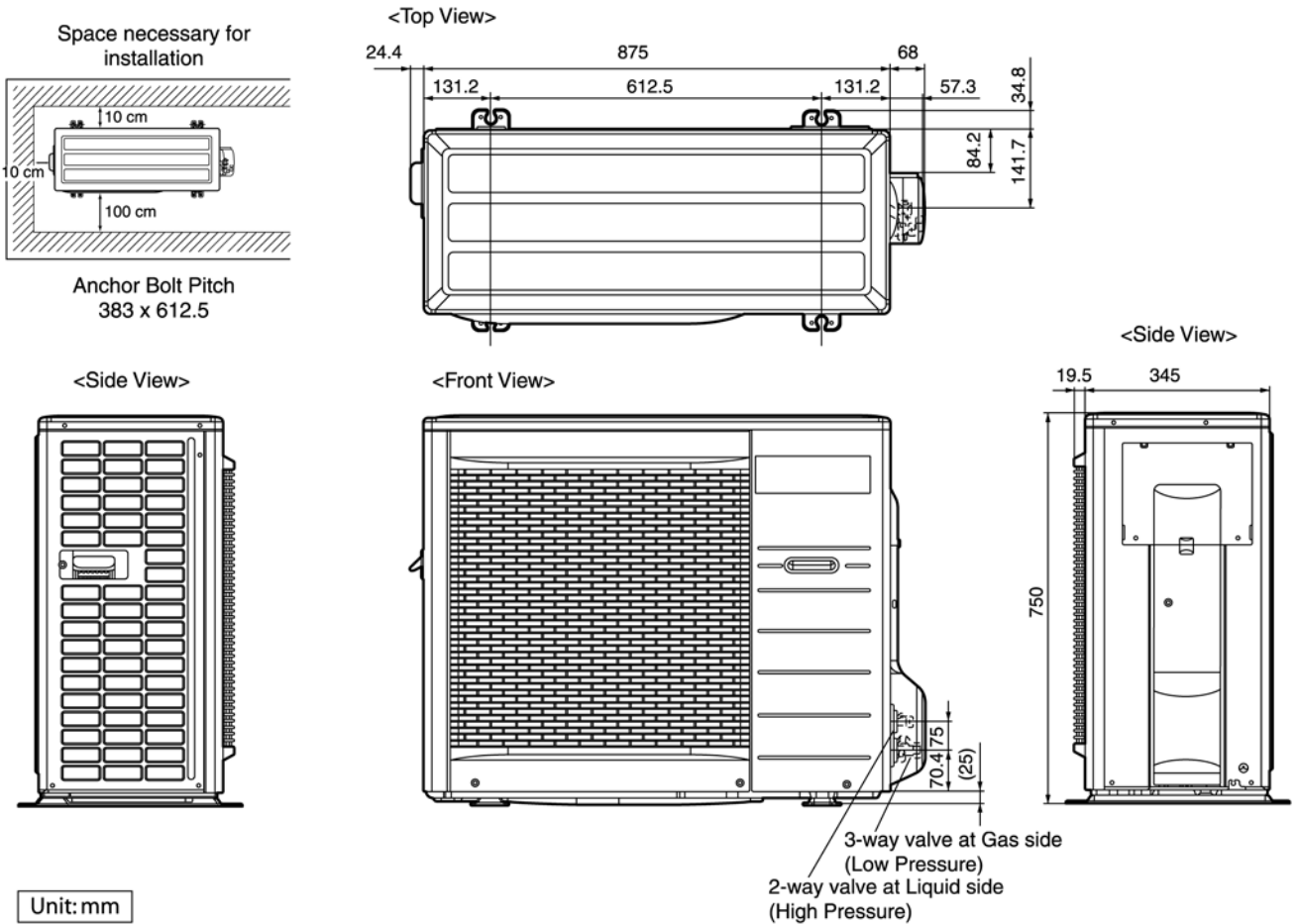

6 Refrigeration Cycle Diagram

6.1. CU-E7JKE CU-E9JKE CU-E12JKE CU-E15JKE-1

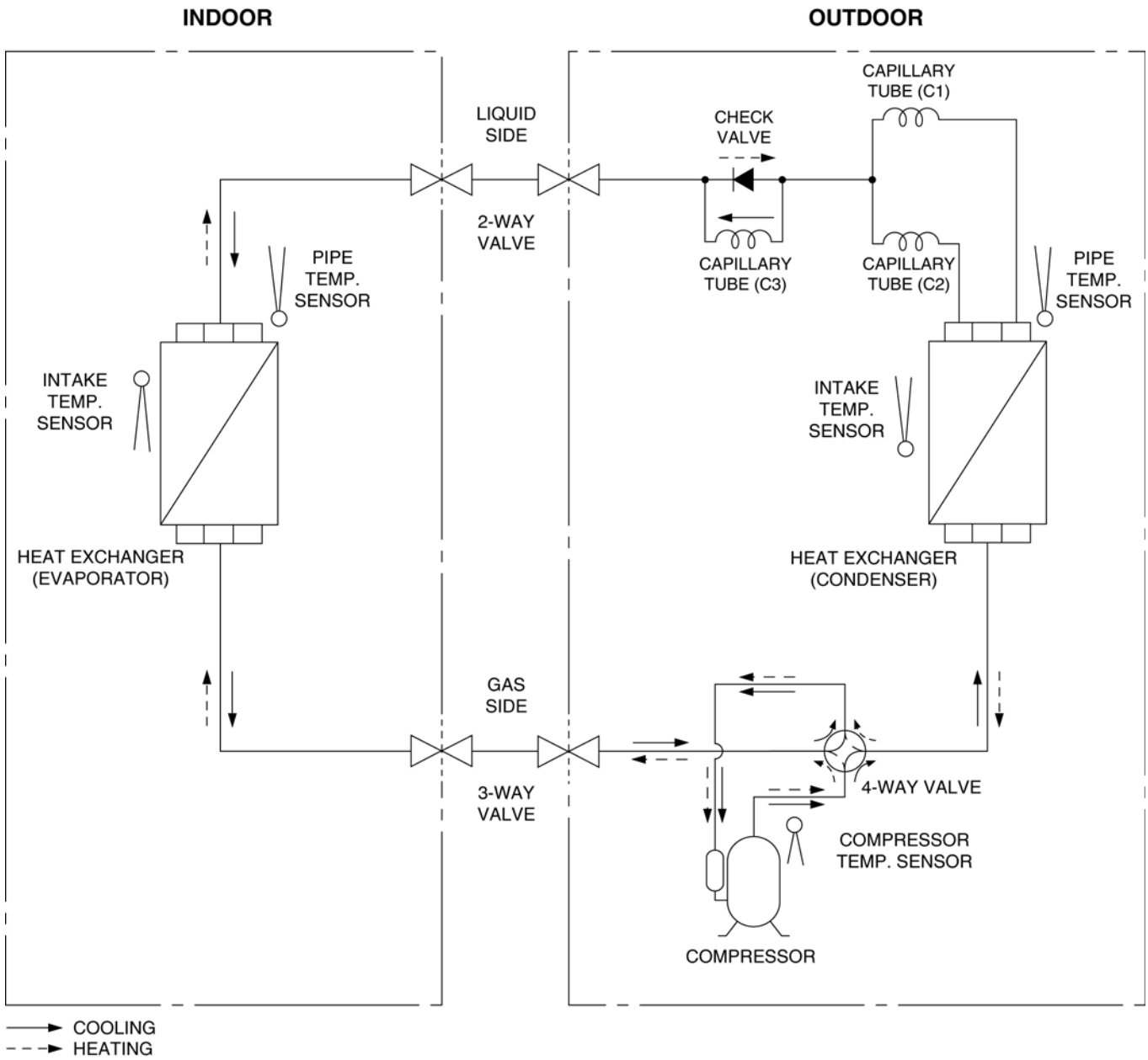

6.2. CU-E7JKE-3 CU-E9JKE-3 CU-E12JKE-3

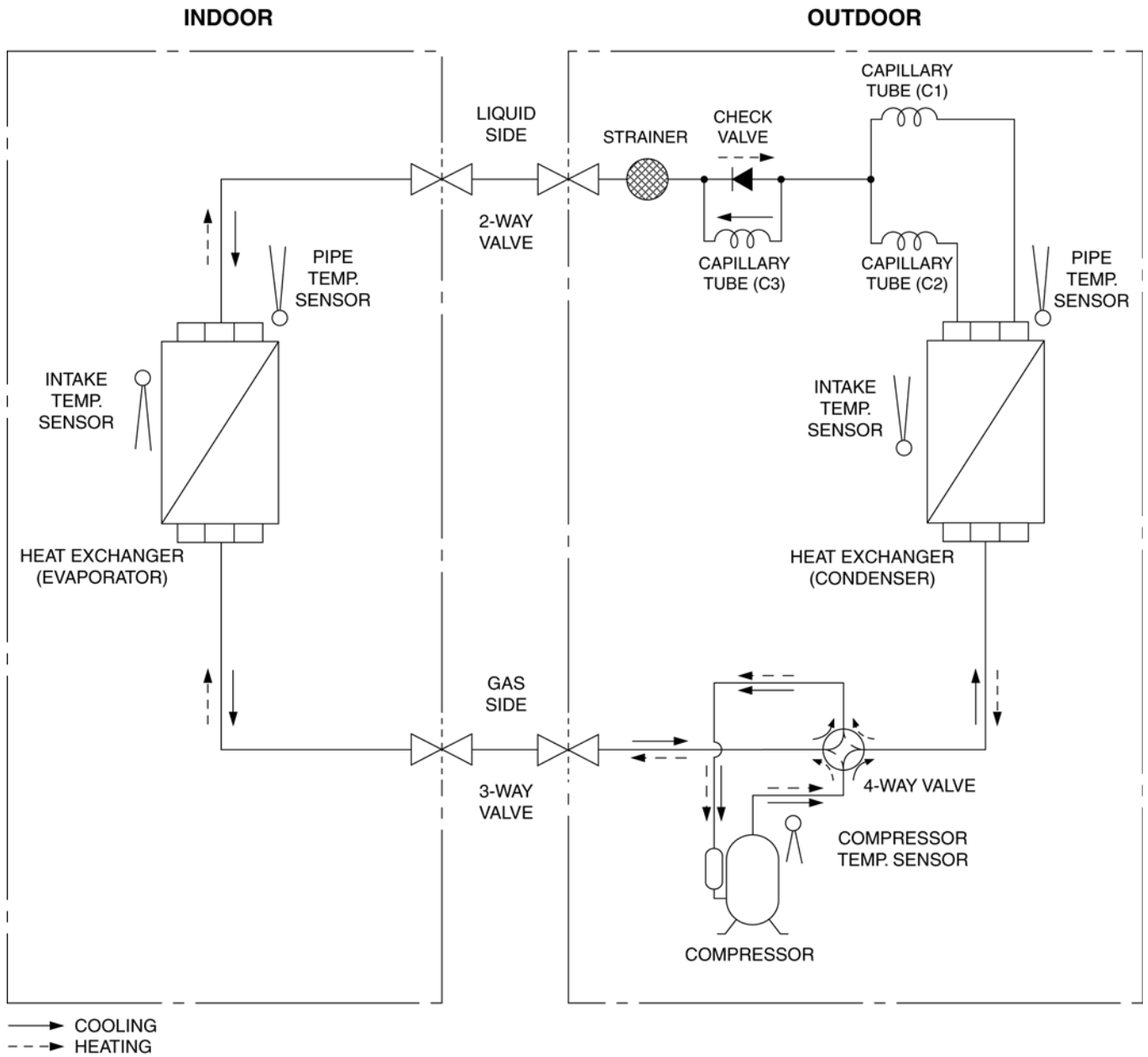

6.3. CU-E15JKE

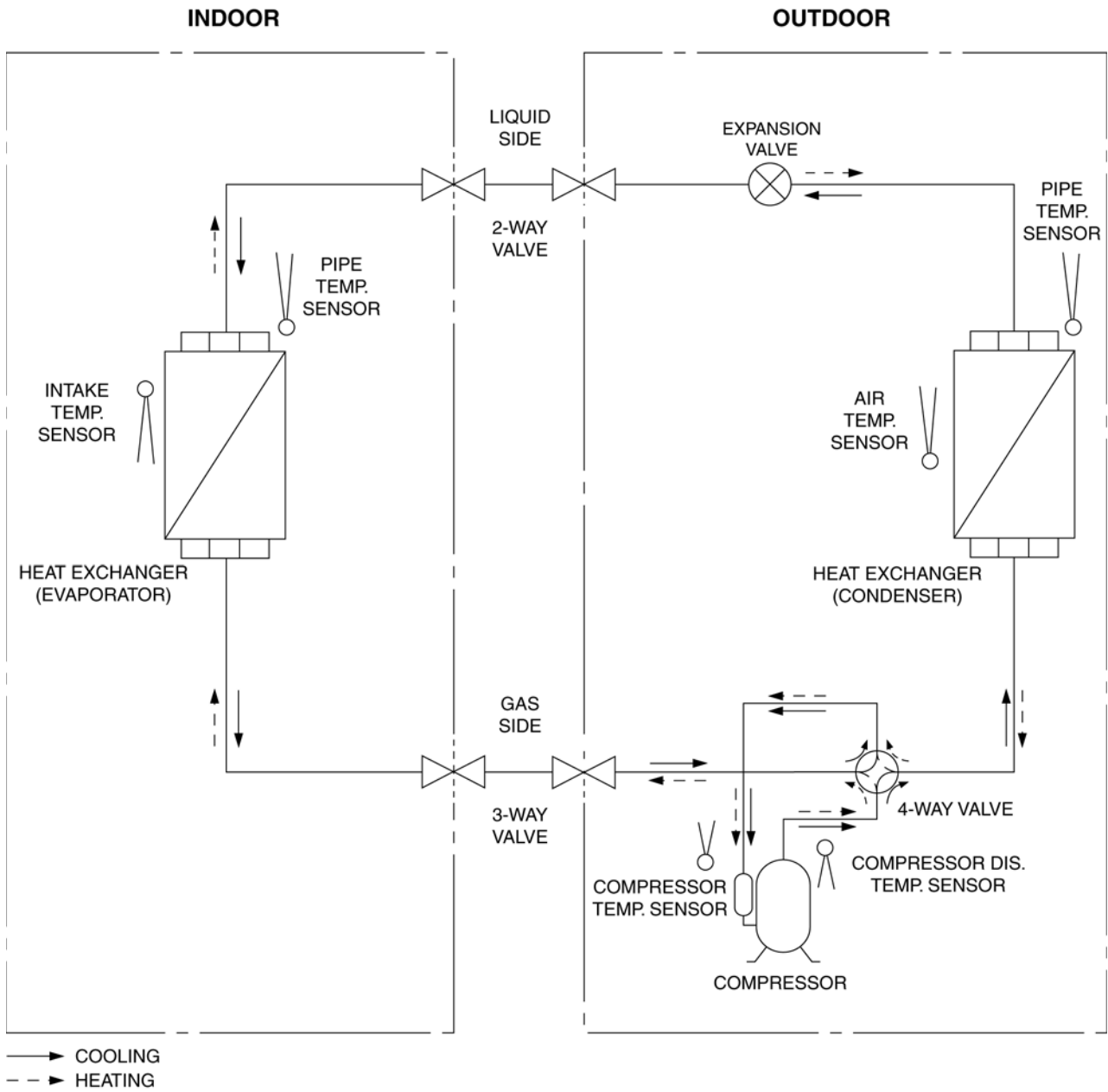

7 Block Diagram

7.1. CU-E7JKE CU-E9JKE CU-E12JKE CU-E15JKE-1

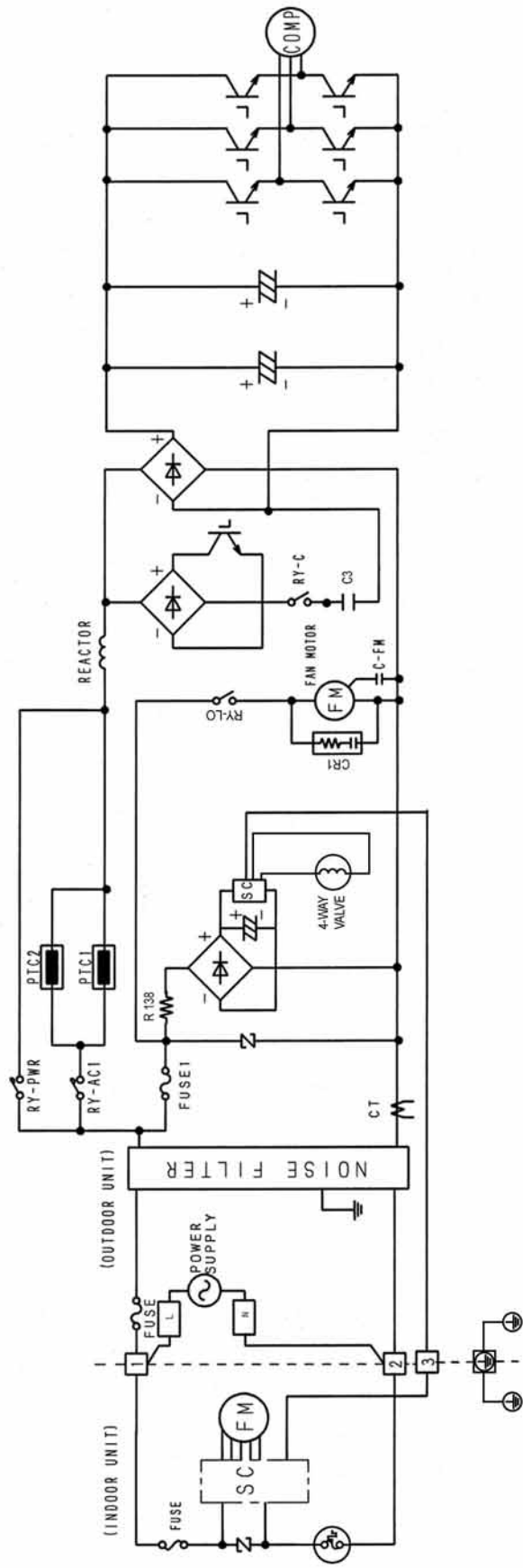

7.2. CU-E7JKE-3 CU-E9JKE-3 CU-E12JKE-3

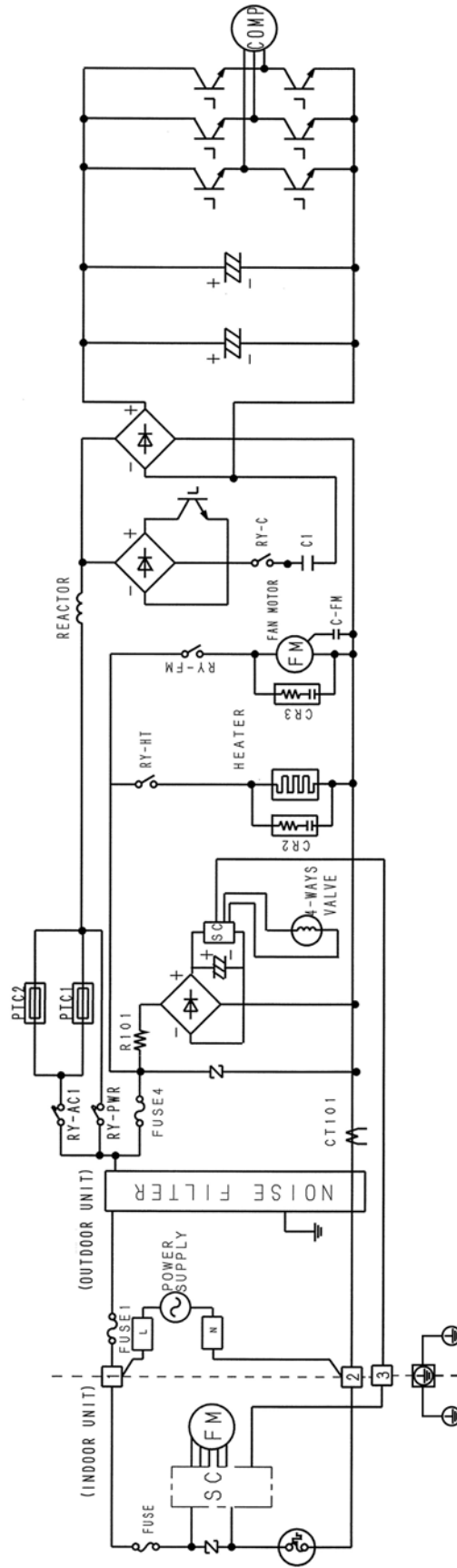

7.3. CU-E15JKE

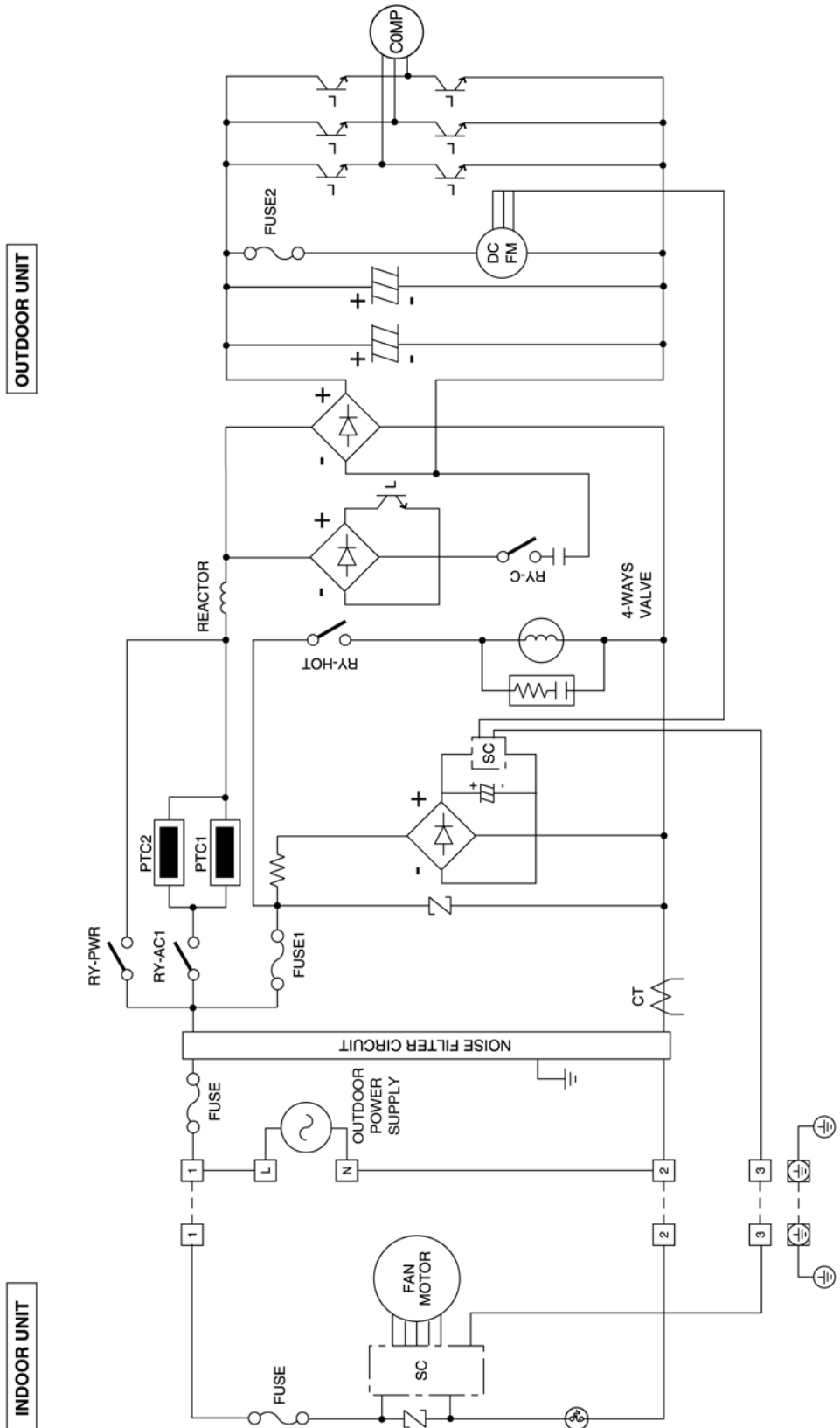

8 Wiring Connection Diagram

8.1. Indoor Unit

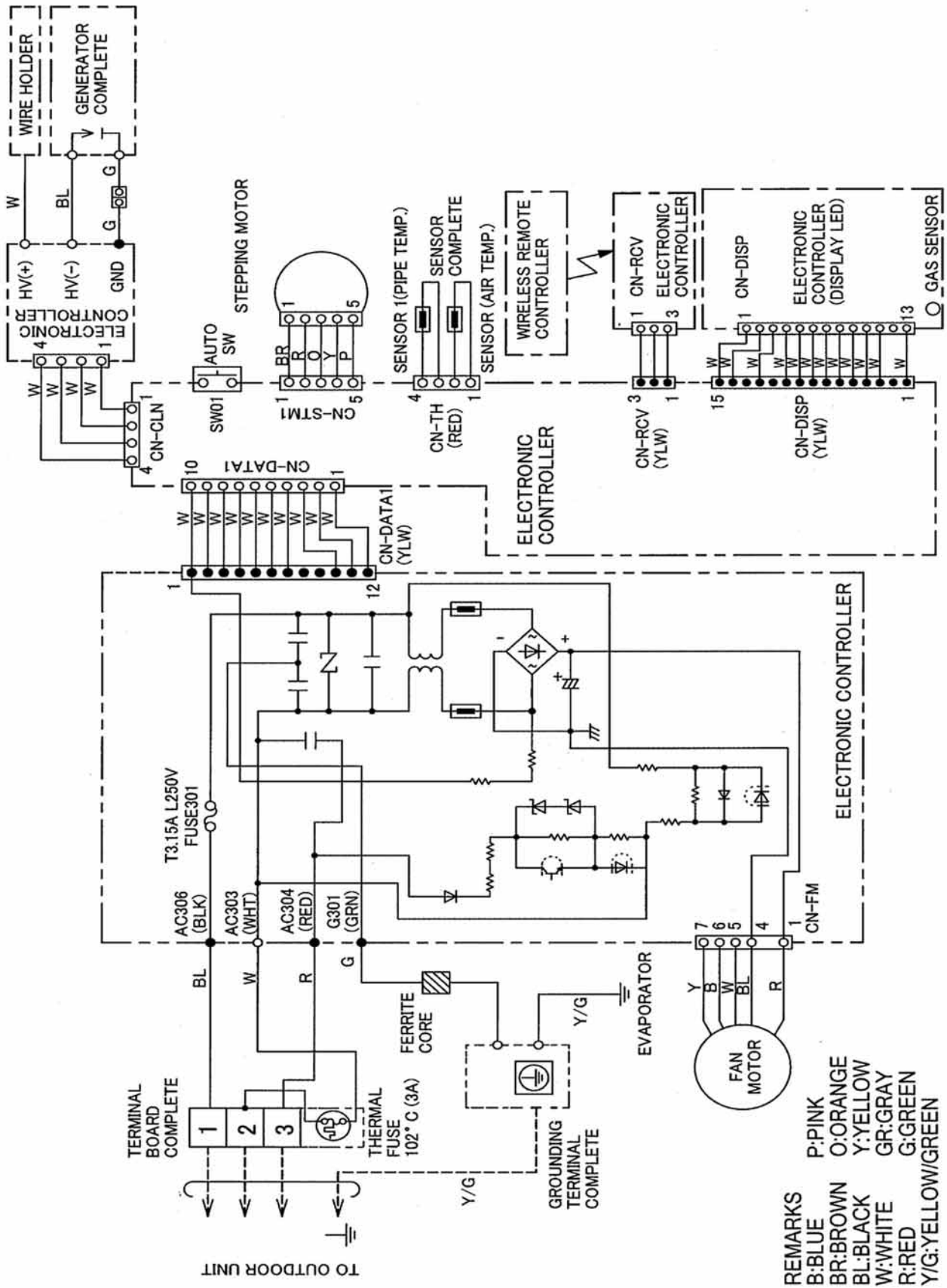

8.2. Outdoor Unit

8.2.1. CU-E7JKE CU-E9JKE CU-E12JKE

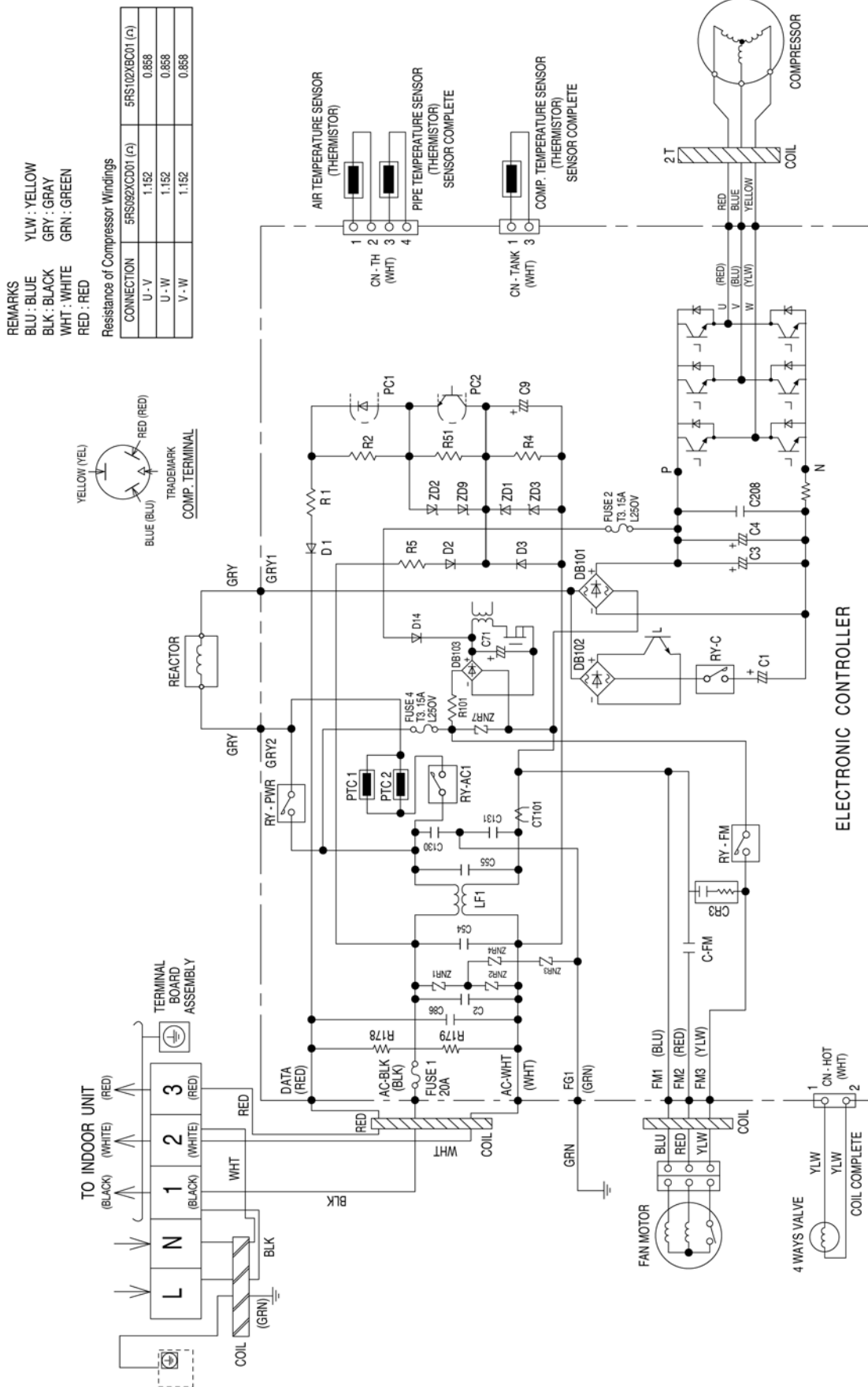

8.2.2. CU-E15JKE

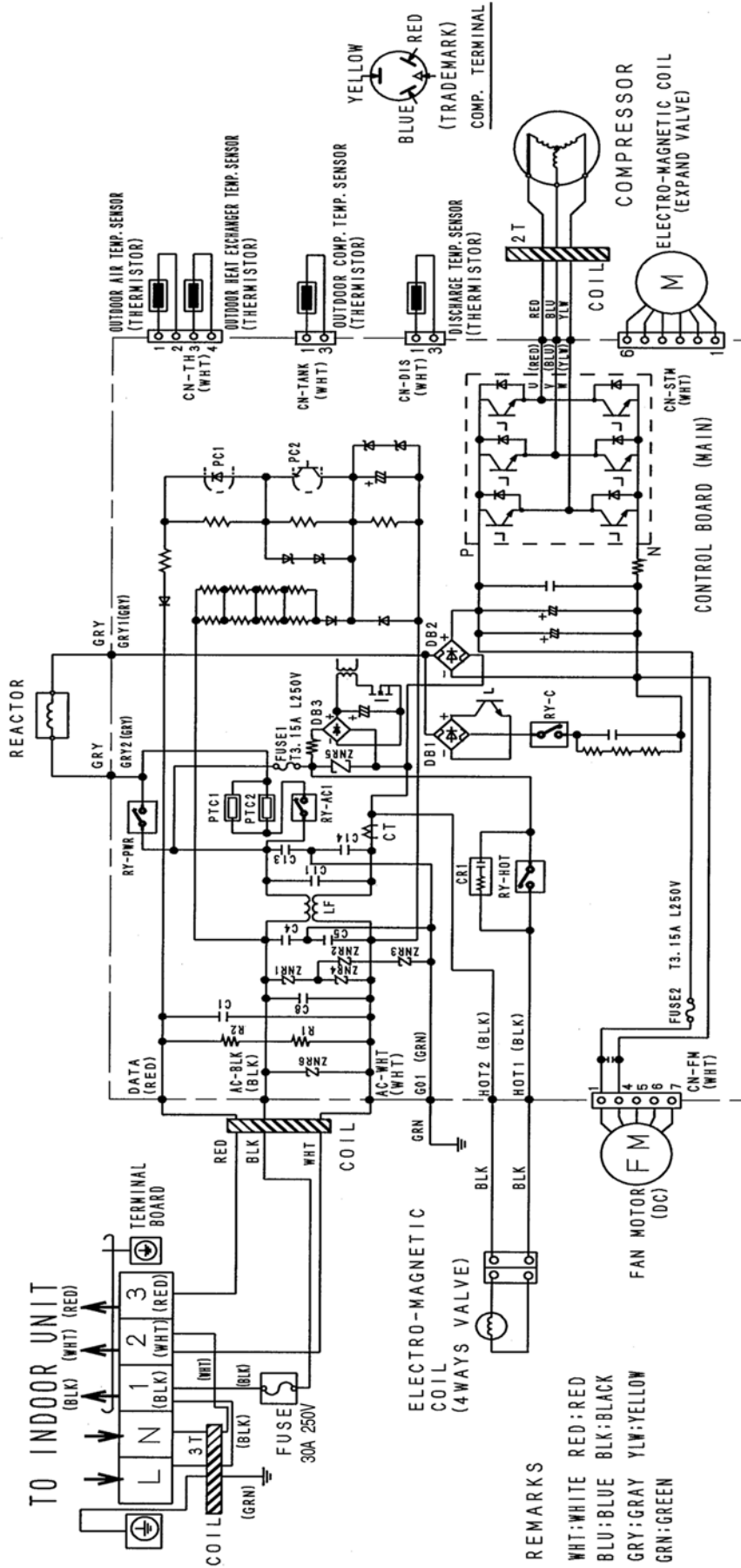

Resistance of Compressor Windings

CONNECTION	5CS130XAD04 (Ω)
U - V	0.9
V - W	0.9
U - W	0.9

8.2.3. CU-E7JKE-3 CU-E9JKE-3 CU-E12JKE-3

REMARKS
 YLW : YELLOW
 BLU : BLUE
 GRY : GRAY
 BLK : BLACK
 WHT : WHITE
 GRN : GREEN
 RED : RED

Resistance of Compressor Windings

CONNECTION	CU-E7HKE-3	CU-E9HKE-3	CU-E12HKE-3
U-V	1.152	0.868	0.868
U-W	1.152	0.868	0.868
V-W	1.152	0.868	0.868

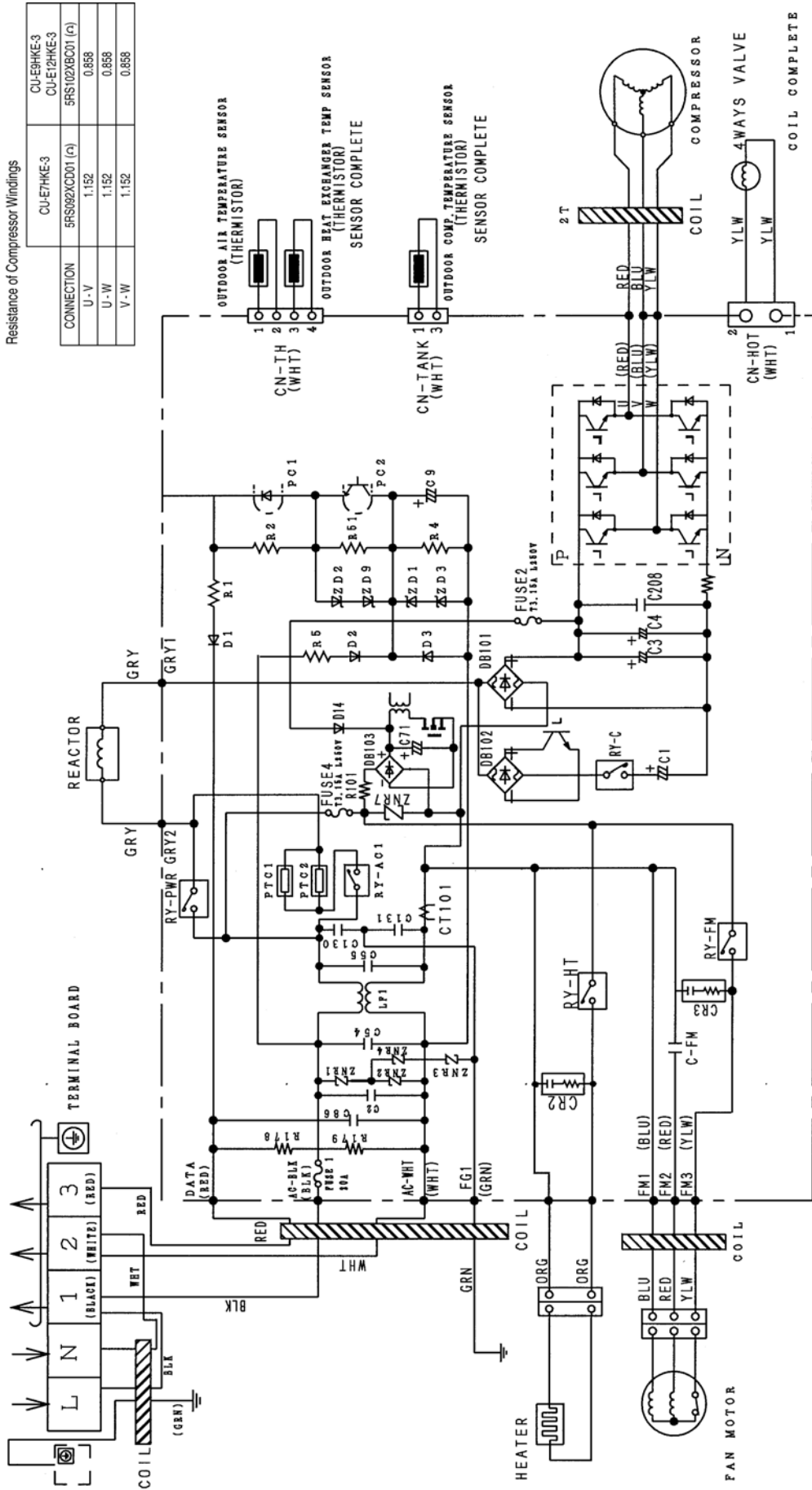

8.2.4. CU-E15JKE-1

REMARKS
 BLU : BLUE
 BLK : BLACK
 WHT : WHITE
 RED : RED

YLW : YELLOW
 GRY : GRAY
 GRN : GREEN

Resistance of Compressor Windings

CONNECTION	5RS102XBC01 (Ω)
U - V	0.868
U - W	0.868
V - W	0.868

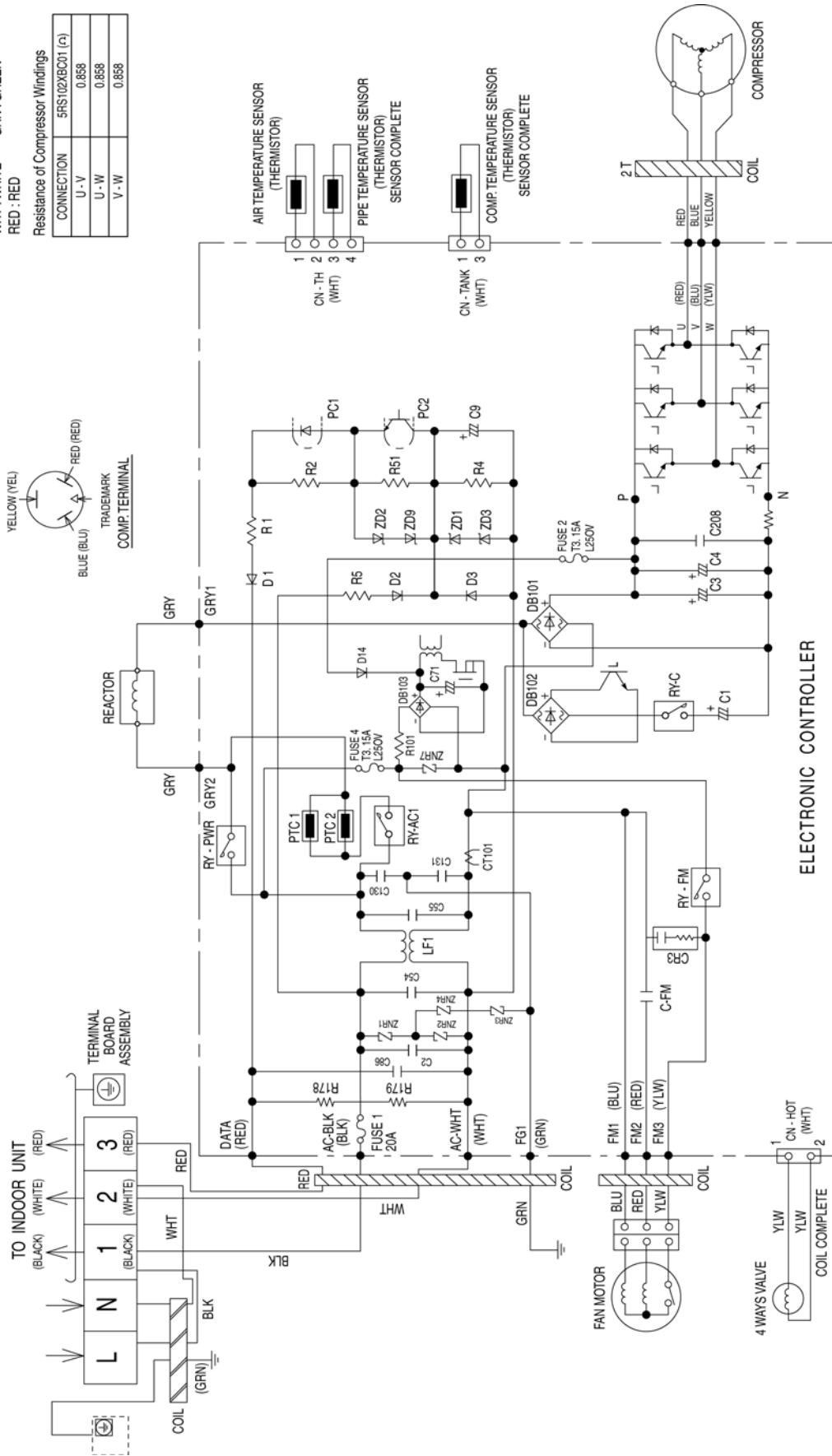

9 Electronic Circuit Diagram

9.1. Indoor Unit

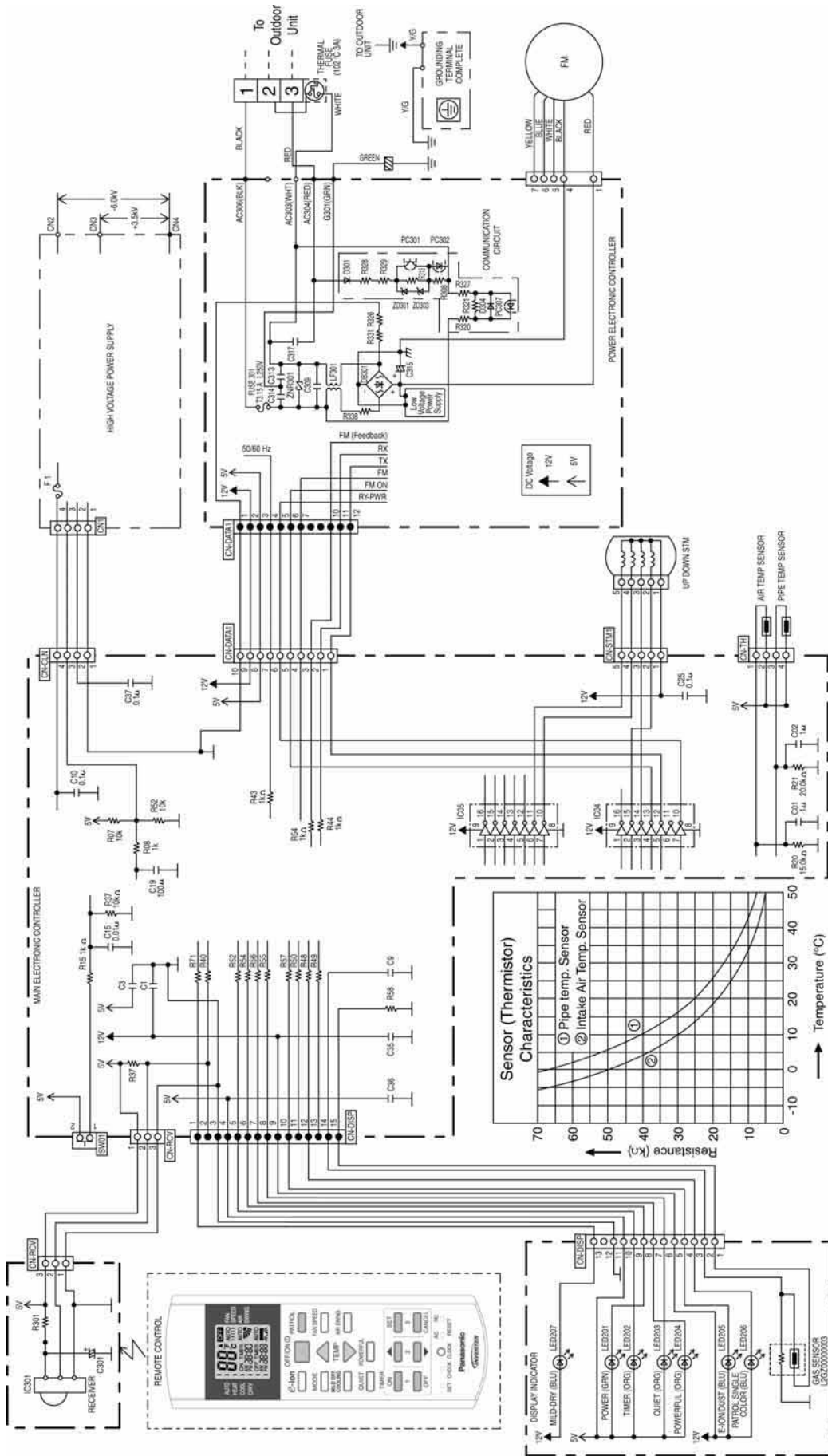

9.2. Outdoor Unit

9.2.1. CU-E7JKE CU-E9JKE CU-E12JKE

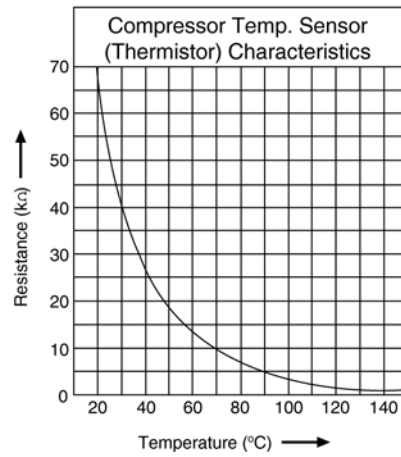
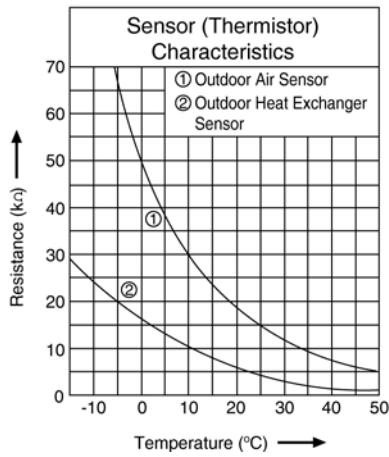
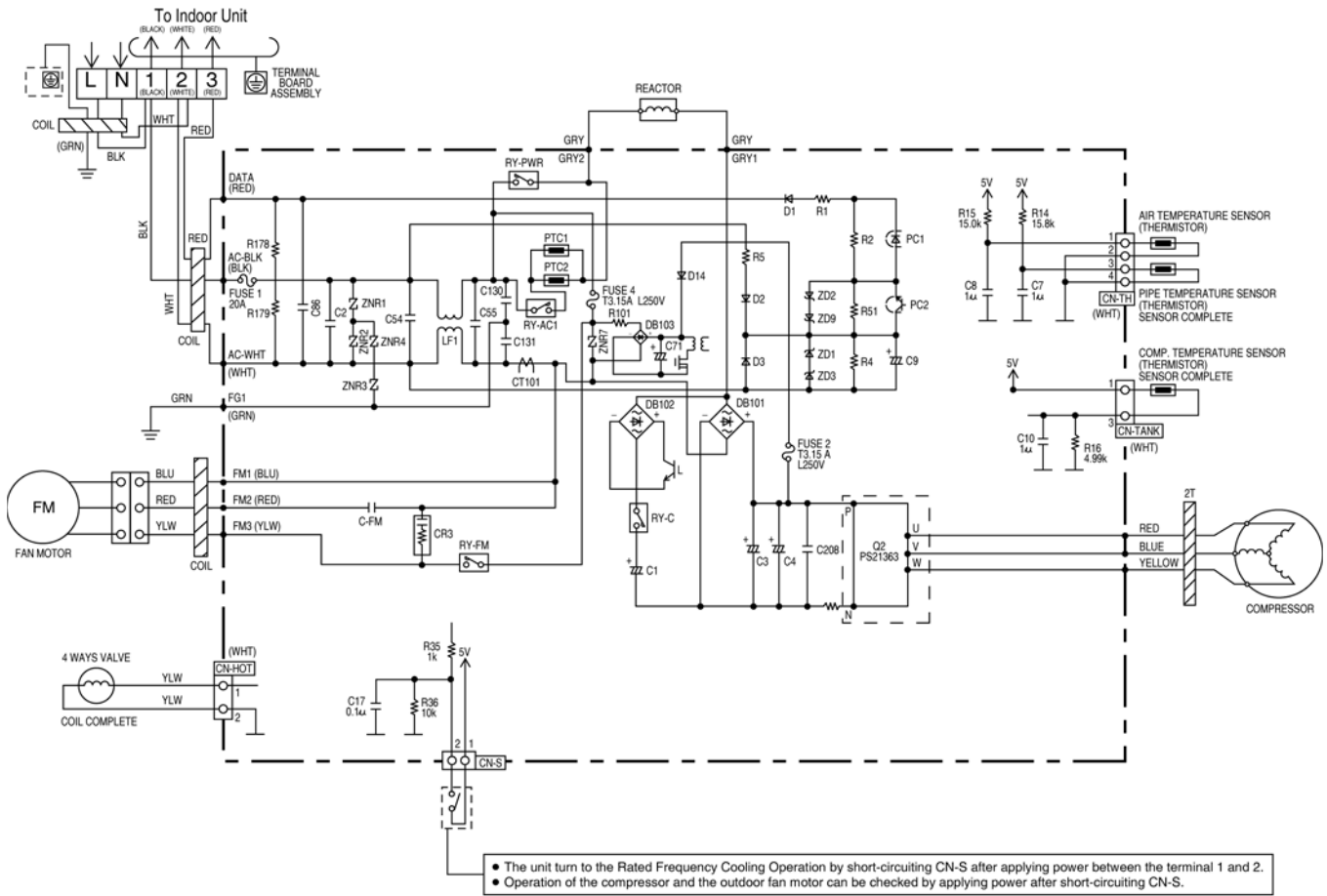

9.2.2. CU-E15JKE

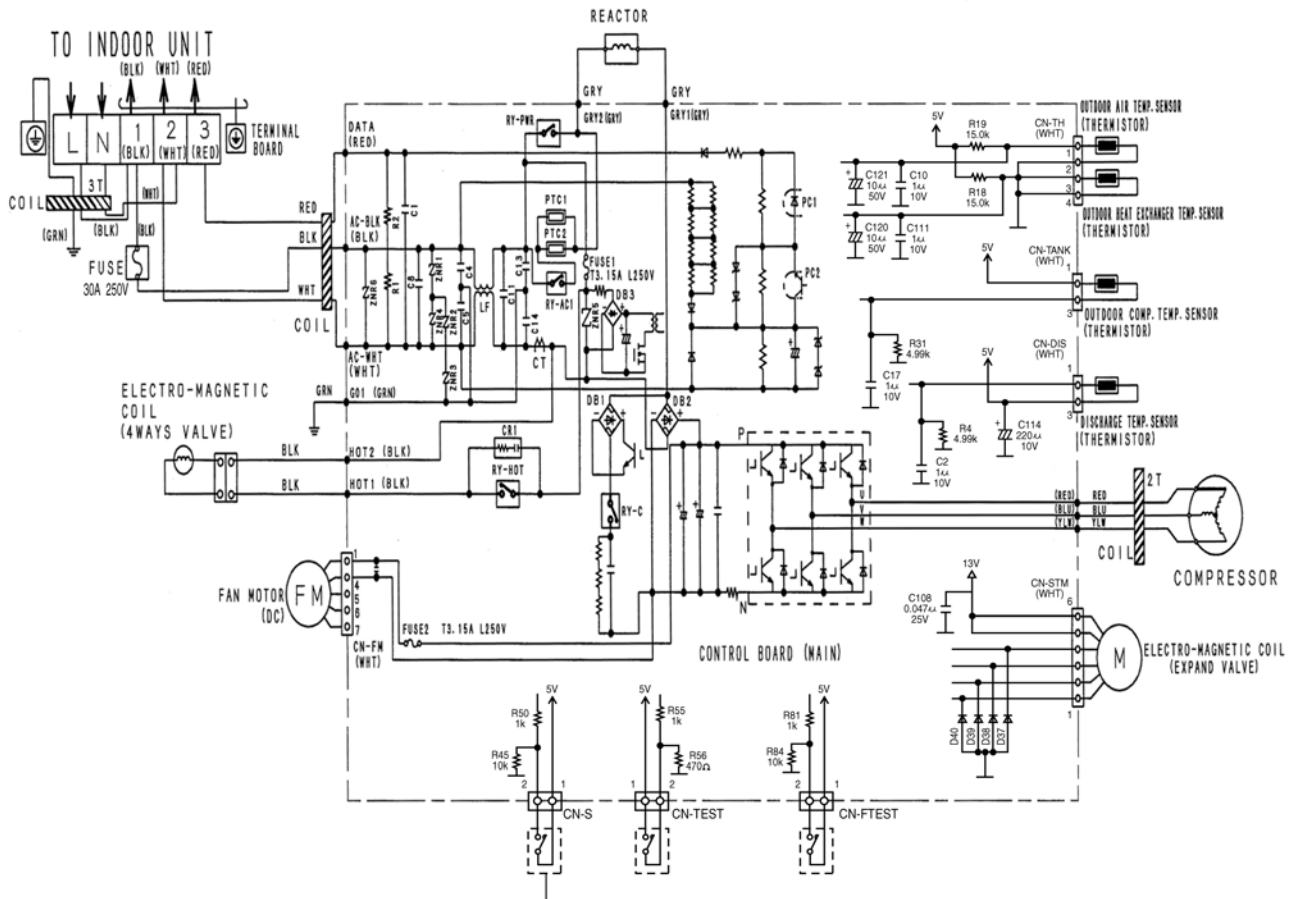

- The unit turn to the Rated Frequency Cooling Operation by short-circuiting CN-S after applying power between the terminal 1 and 2.
- Operation of the compressor and the outdoor fan motor can be checked by applying power after short-circuiting CN-S.

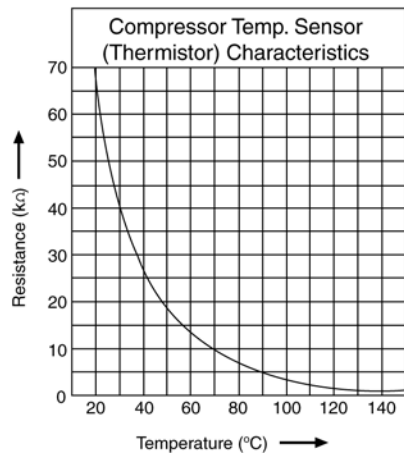
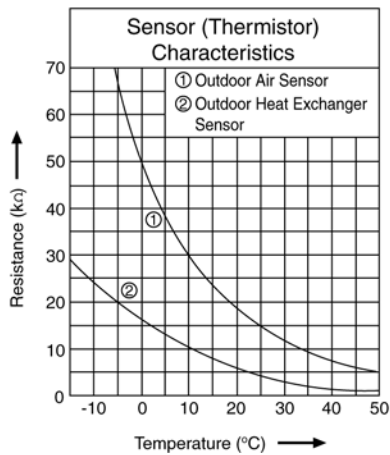

9.2.3. CU-E7JKE-3 CU-E9JKE-3 CU-E12JKE-3

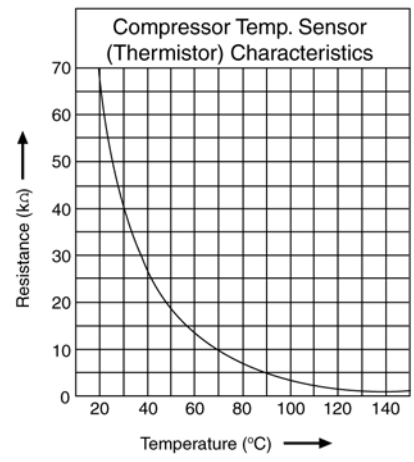
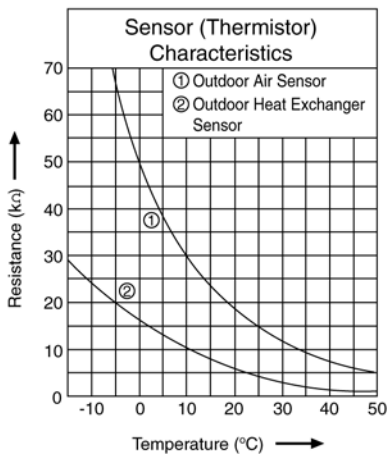
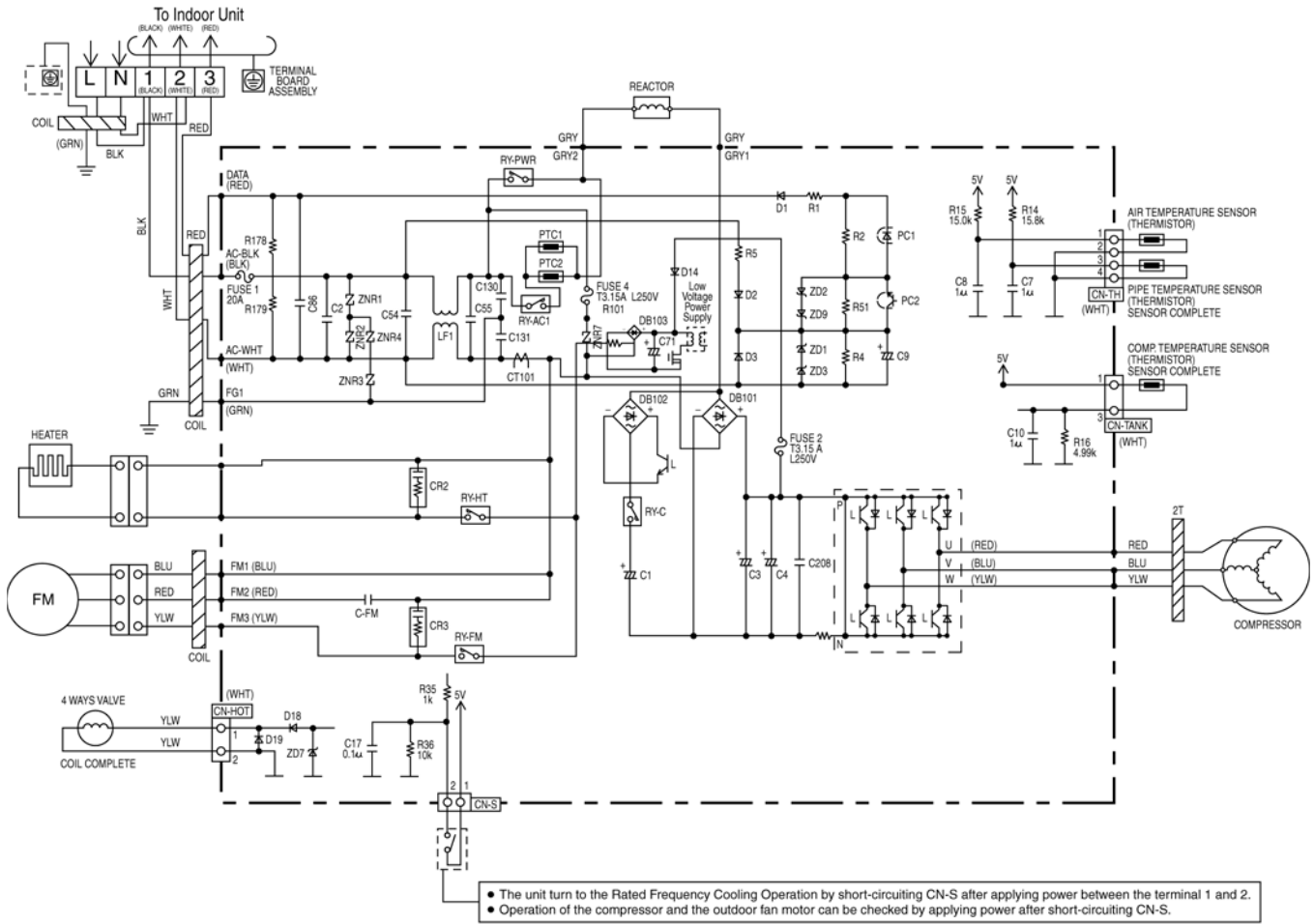

9.2.4. CU-E15JKE-1

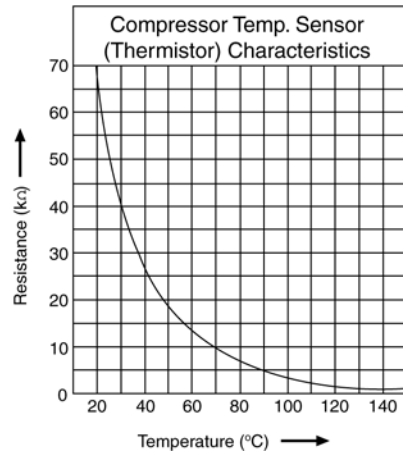
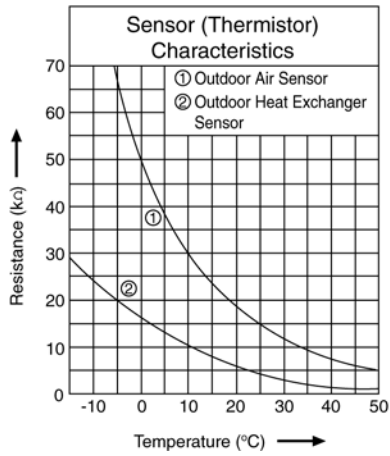
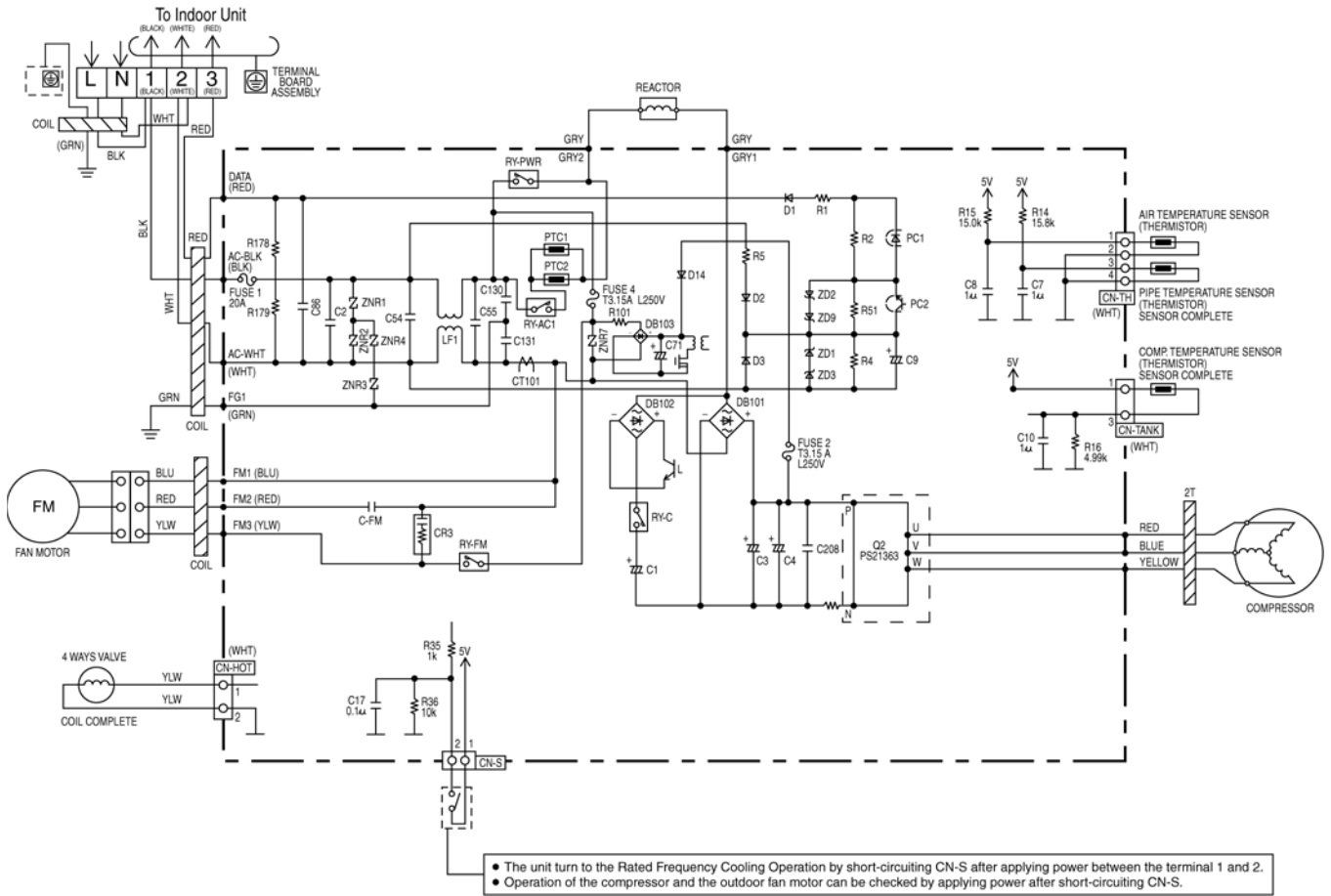

10 Printed Circuit Board

10.1. Indoor Unit

10.1.1. Main Printed Circuit Board

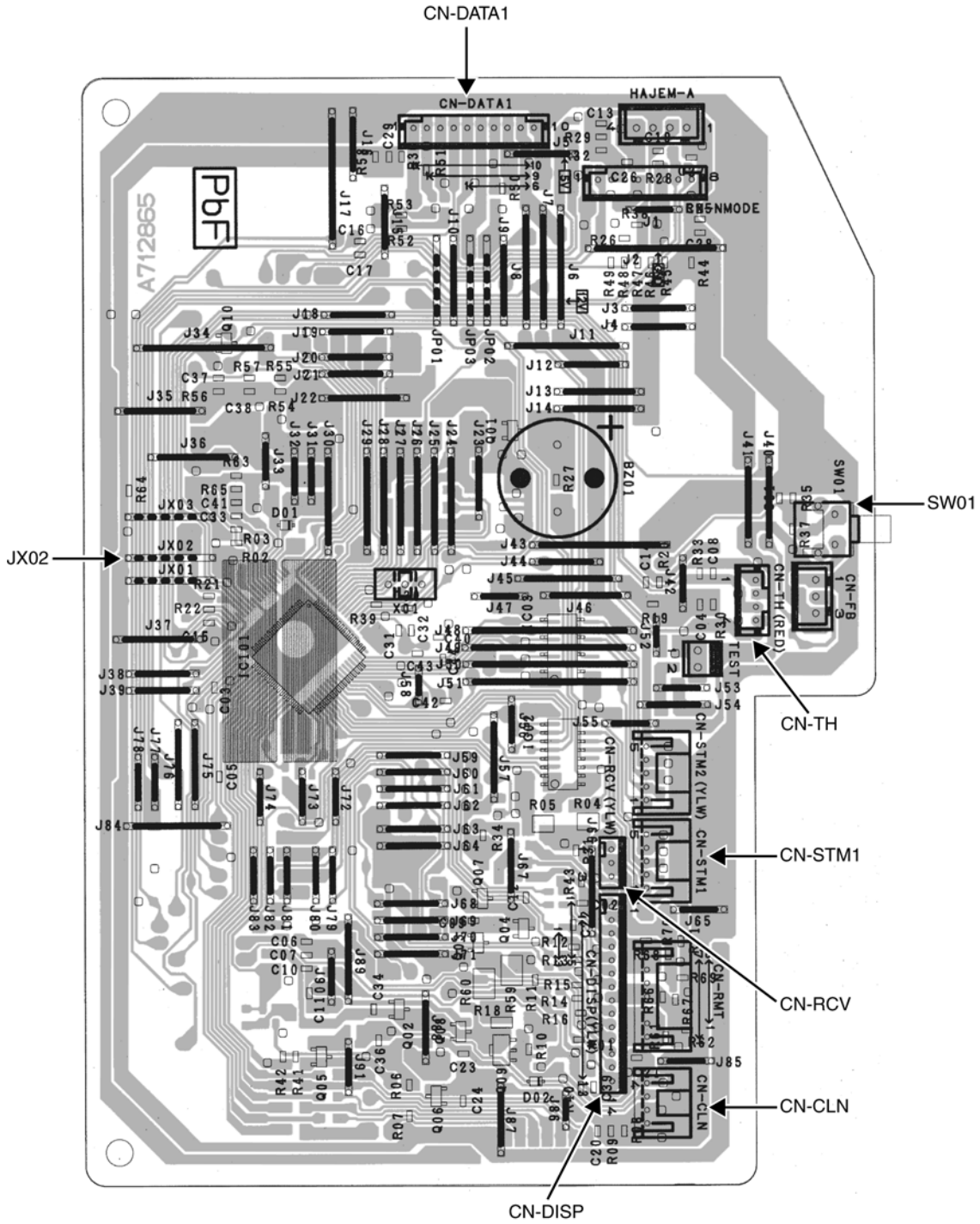

10.1.2. Power Printed Circuit Board

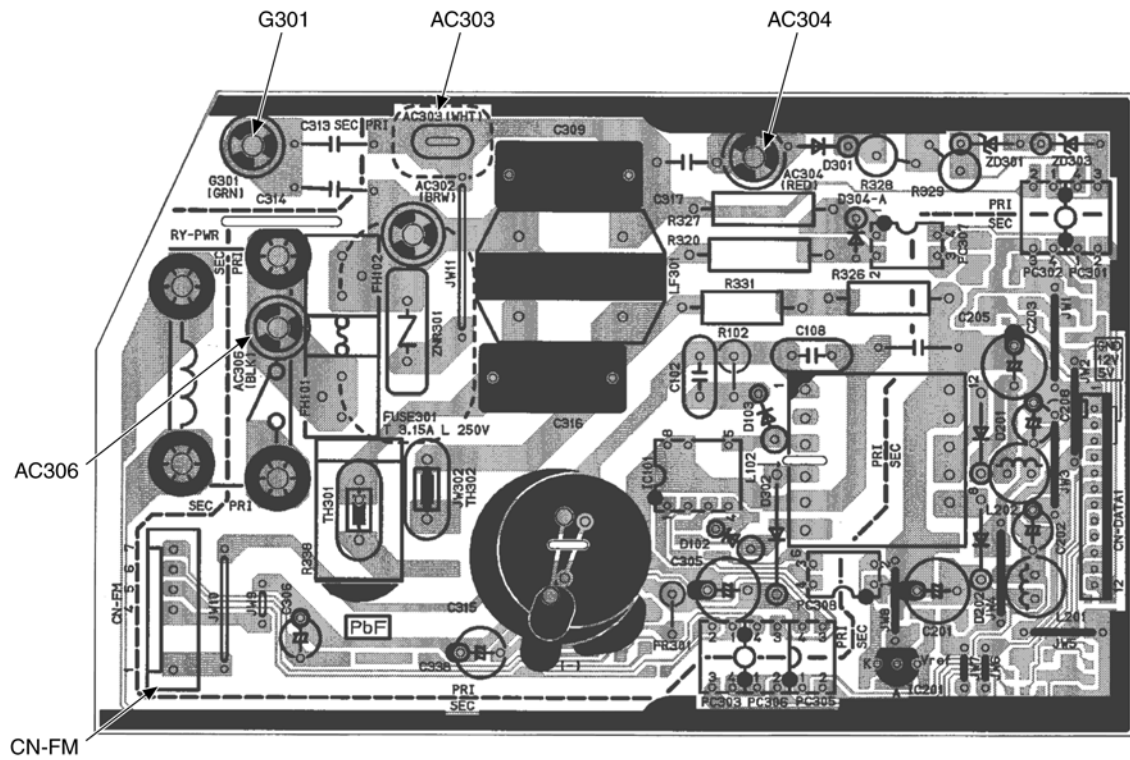

10.1.3. Indicator Printed Circuit Board

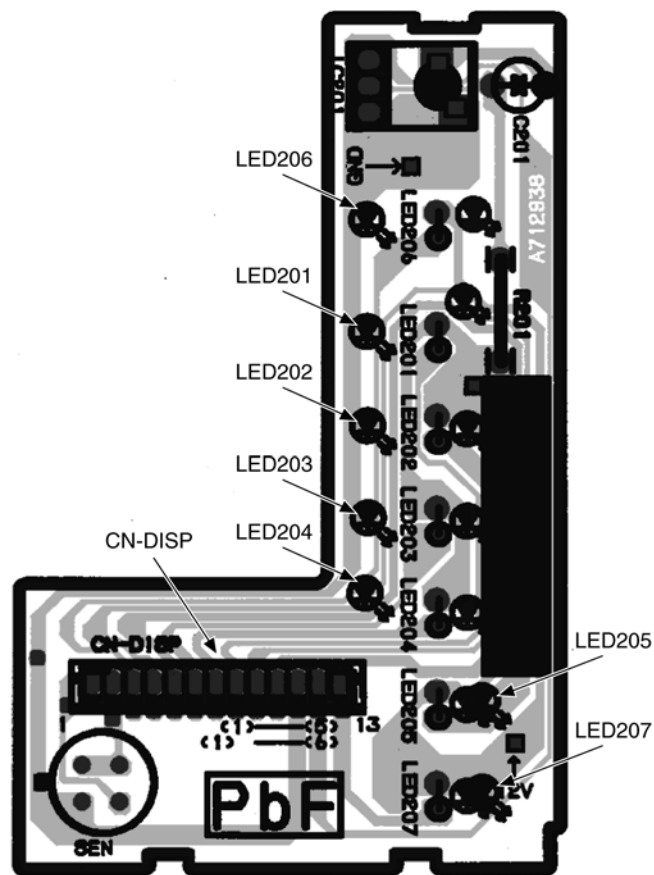

10.1.4. Receiver Printed Circuit Board

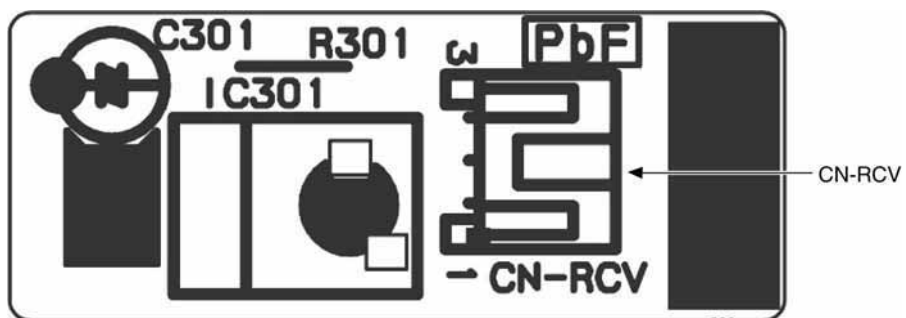

10.1.5. High Voltage Power Supply Printed Circuit Board

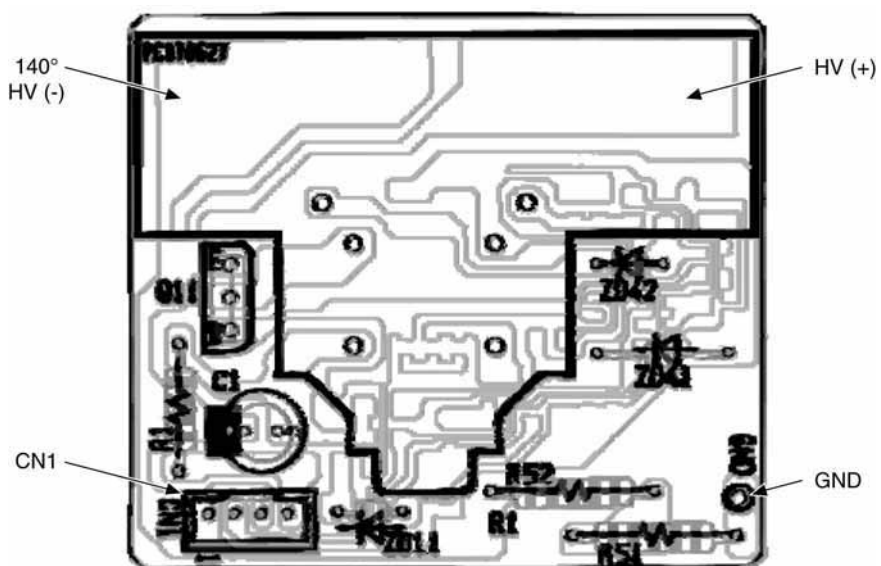

10.2. Outdoor Unit

10.2.1. CU-E7JKE CU-E9JKE CU-E12JKE CU-E15JKE-1

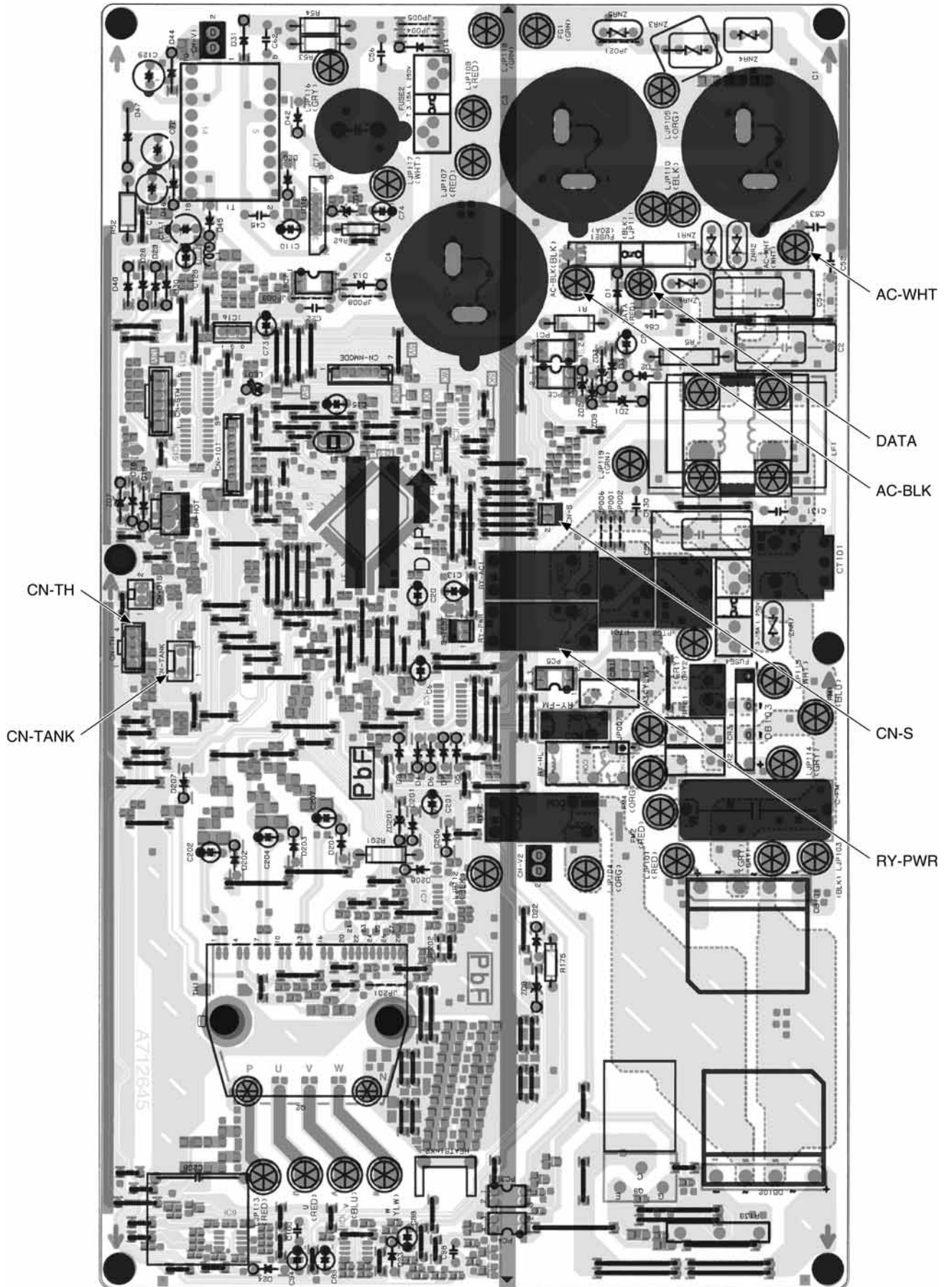

10.2.2. CU-E15JKE

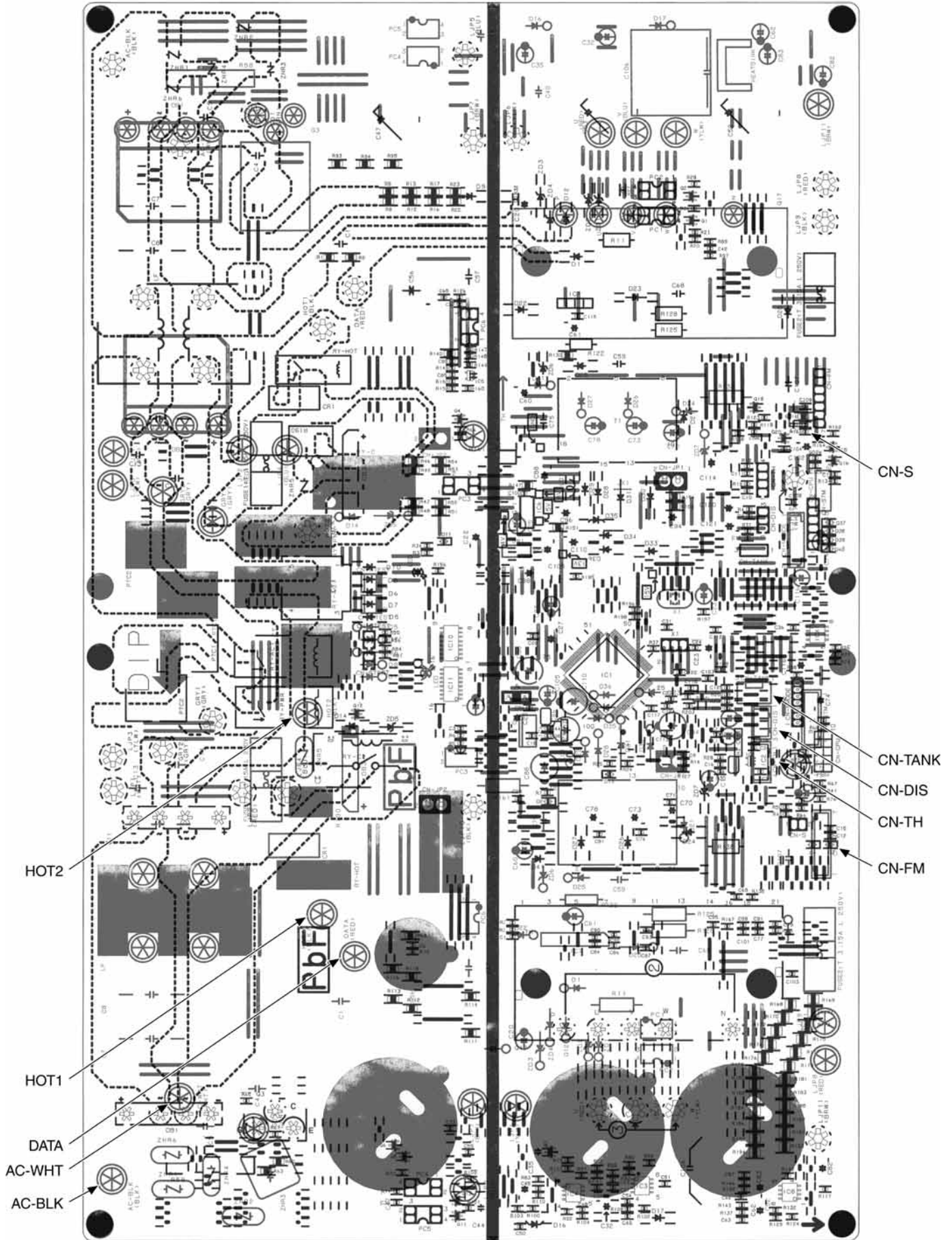

10.2.3. CU-E7JKE-3 CU-E9JKE-3 CU-E12JKE-3

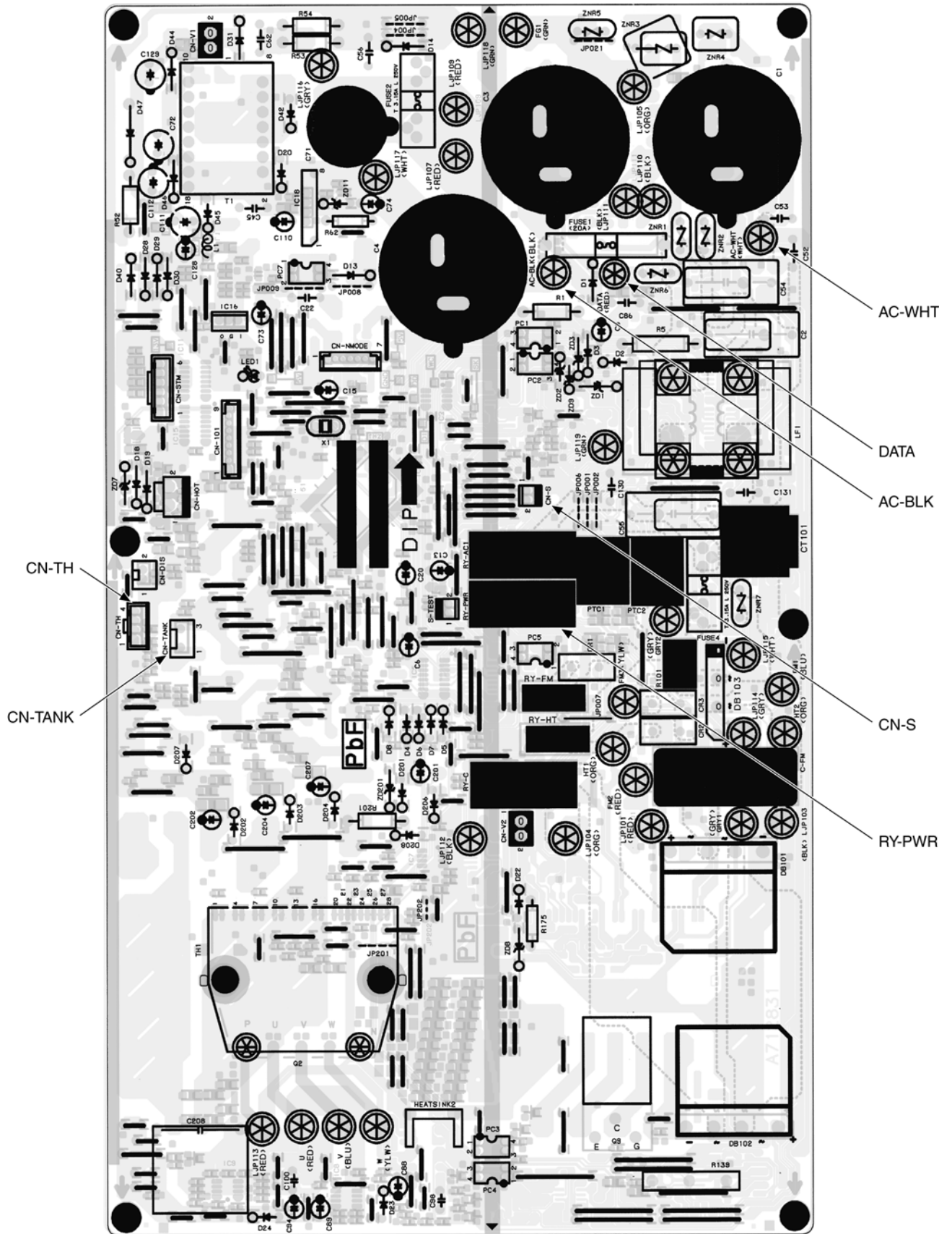

11 Installation Instruction

11.1. Select the Best Location

11.1.1. Indoor Unit

- Do not install the unit in excessive oil fume area such as kitchen, workshop and etc.
- There should not be any heat source or steam near the unit.
- There should not be any obstacles blocking the air circulation.
- A place where air circulation in the room is good.
- A place where drainage can be easily done.
- A place where noise prevention is taken into consideration.
- Do not install the unit near the door way.
- Ensure the spaces indicated by arrows from the wall, ceiling, fence or other obstacles.
- Recommended installation height for indoor unit shall be at least 2.5 m.

11.1.2. Outdoor Unit

- If an awning is built over the unit to prevent direct sunlight or rain, be careful that heat radiation from the condenser is not obstructed.
- There should not be any animal or plant which could be affected by hot air discharged.
- Keep the spaces indicated by arrows from wall, ceiling, fence or other obstacles.
- Do not place any obstacles which may cause a short circuit of the discharged air.
- If piping length is over the [piping length for additional gas], additional refrigerant should be added as shown in the table.

Model	Horse Power (HP)	Piping size		Std. Length (m)	Max. Elevation (m)	Min. Piping Length (m)	Max. Piping Length (m)	Additional Refrigerant (g/m)	Piping Length for add. gas (m)
		Gas	Li- quid						
E7***, XE7***	3/4 ~ 1.75HP	3/8"	1/4"	5	15	3	15	20	7.5
E9***, XE9***					15	3	15	20	7.5
E12***, XE12***					15	3	15	20	7.5
E15***, XE15***					15	3	15	20	7.5
E18***, XE18***	2.0 ~ 3.0HP	1/2"	1/4"	5	15	3	20	20	10
E21***, XE21***					15	3	20	20	10
E24***, XE24***					20	3	30	30	10
E28***					20	3	30	30	10

Example: For E9***

If the unit is installed at 10 m distance, the quantity of additional refrigerant should be 38 g (10-7.5) m x 15 g/m = 38 g

11.1.3. Indoor/Outdoor Unit Installation Diagram

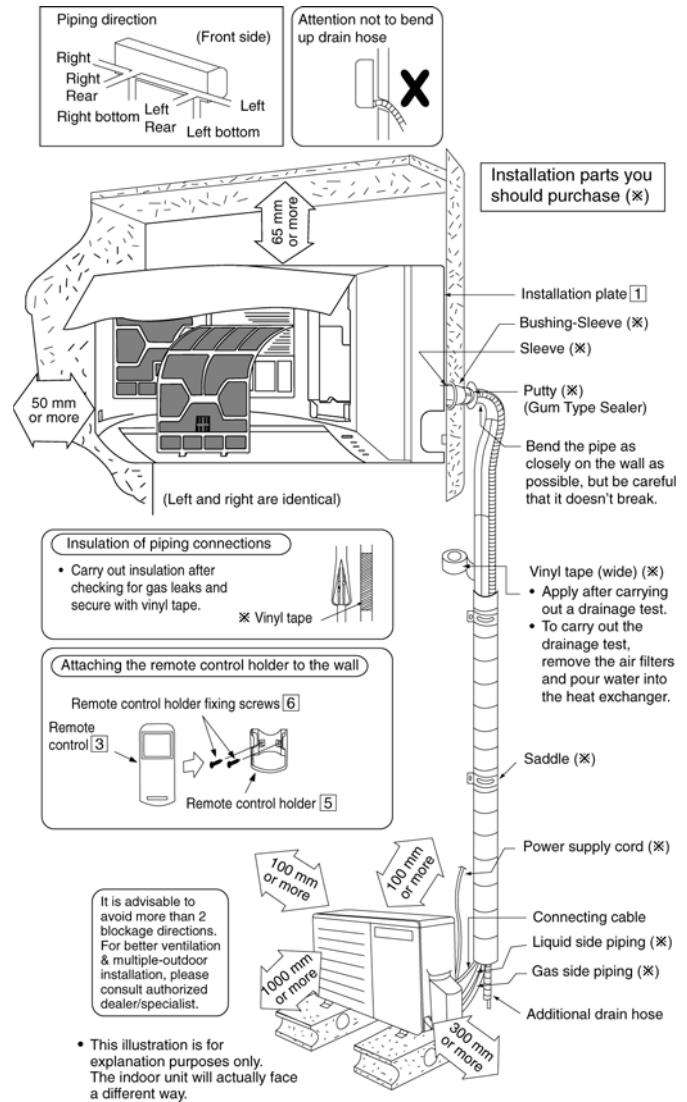

11.2. Indoor Unit

11.2.1. How to Fix Installation Plate

The mounting wall is strong and solid enough to prevent it from the vibration.

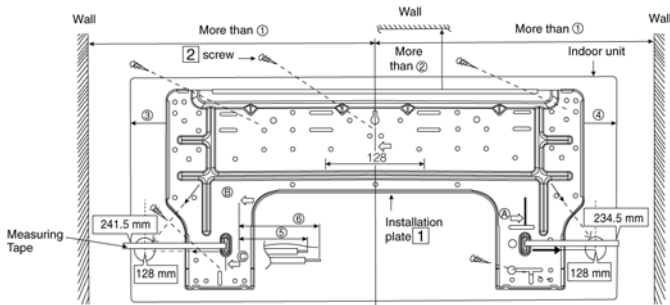

Model	Dimension					
	①	②	③	④	⑤	⑥
E7***, XE7*** E9***, XE9*** E12***, XE12*** E15***, XE15***	485 mm	82 mm	165 mm	158 mm	43 mm	95 mm
E18***, XE18*** E21***, XE21*** E24***, XE24*** E28***	585 mm	82 mm	165 mm	158 mm	169 mm	219 mm

The centre of installation plate should be at more than ① at right and left of the wall.

The distance from installation plate edge to ceiling should more than ②.

From installation plate left edge to unit's left side is ③.

From installation plate right edge to unit's right is ④.

⑤ : For left side piping, piping connection for liquid should be about ⑤ from this line.

⑥ : For left side piping, piping connection for gas should be about ⑥ from this line.

1. Mount the installation plate on the wall with 5 screws or more (at least 5 screws).

(If mounting the unit on the concrete wall, consider using anchor bolts.)

- Always mount the installation plate horizontally by aligning the marking-off line with the thread and using a level gauge.

2. Drill the piping plate hole with $\varnothing 70$ mm hole-core drill.

- Line according to the left and right side of the installation plate. The meeting point of the extended line is the center of the hole. Another method is by putting measuring tape at position as shown in the diagram above. The hole center is obtained by measuring the distance namely 128 mm for left and right hole respectively.
- Drill the piping hole at either the right or the left and the hole should be slightly slanting to the outdoor side.

11.2.2. To Drill a Hole in the Wall and Install a Sleeve of Piping

1. Insert the piping sleeve to the hole.
2. Fix the bushing to the sleeve.
3. Cut the sleeve until it extrudes about 15 mm from the wall.

Caution

When the wall is hollow, please be sure to use the sleeve for tube ass'y to prevent dangers caused by mice biting the connecting cable.

4. Finish by sealing the sleeve with putty or caulking compound at the final stage.

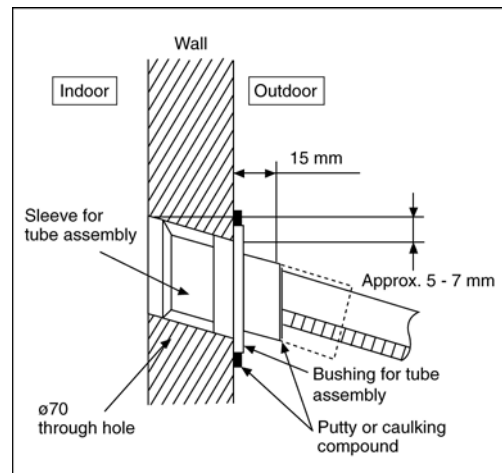

11.2.3. Indoor Unit Installation

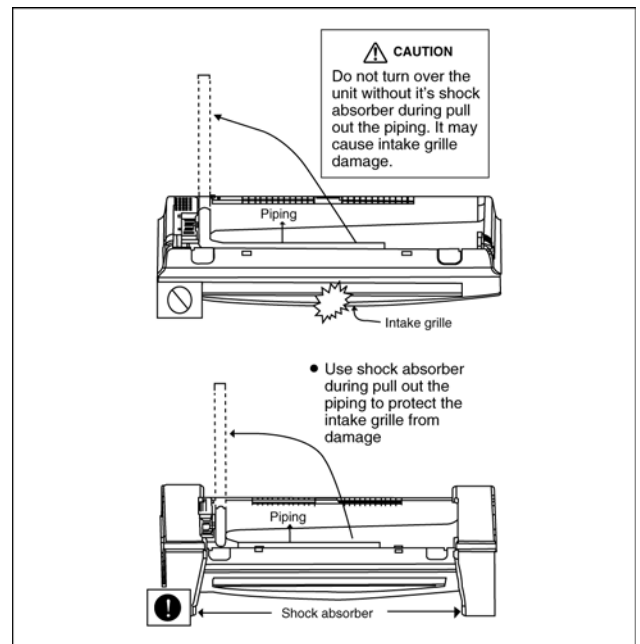

1. For the right rear piping

- Step-1** Pull out the Indoor piping
- Step-2** Install the Indoor Unit
- Step-3** Secure the Indoor Unit
- Step-4** Insert the connecting cable

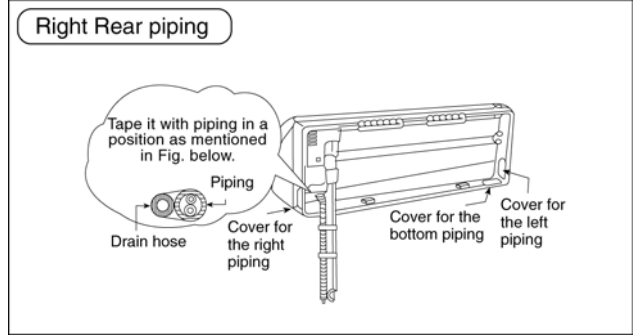

2. For the right and right bottom piping

- Step-1** Pull out the Indoor piping
- Step-2** Install the Indoor Unit
- Step-3** Insert the connecting cable
- Step-4** Secure the Indoor Unit

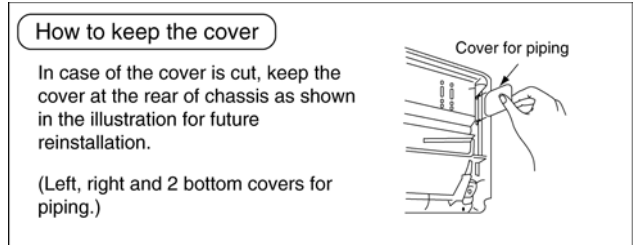

3. For the embedded piping

- Step-1** Replace the drain hose
- Step-2** Bend the embedded piping
 - Use a spring bender or equivalent to bend the piping so that the piping is not crushed.
- Step-3** Pull the connecting cable into Indoor Unit
 - The inside and outside connecting cable can be connected without removing the front grille.
- Step-4** Cut and flare the embedded piping
 - When determining the dimensions of the piping, slide the unit all the way to the left on the installation plate.
 - Refer to the section "Cutting and flaring the piping".
- Step-5** Install the Indoor Unit
- Step-6** Connect the piping
 - Please refer to "Connecting the piping" column in outdoor unit section. (Below steps are done after connecting the outdoor piping and gas-leakage confirmation.)
- Step-7** Insulate and finish the piping
 - Please refer to "Piping and finishing" column of outdoor section and "Insulation of piping connection" column as mentioned in indoor/outdoor unit installation.
- Step-8** Secure the Indoor Unit

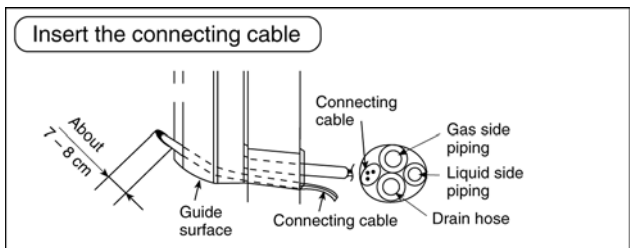
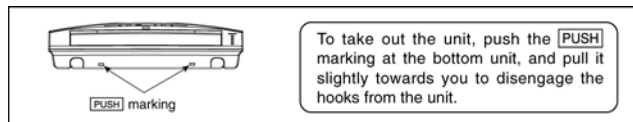
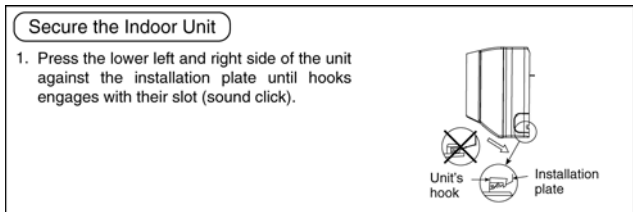
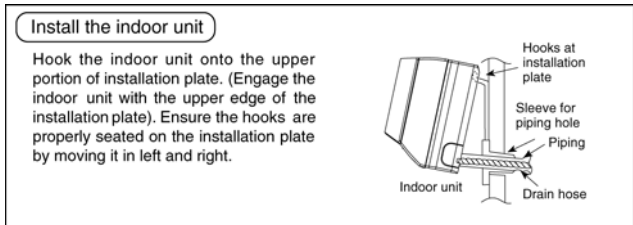
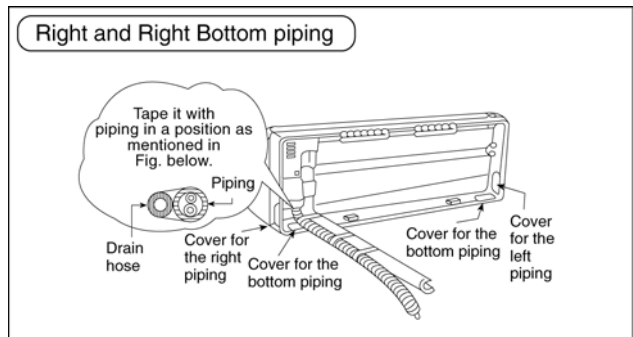

(This can be used for left rear piping and bottom piping also.)

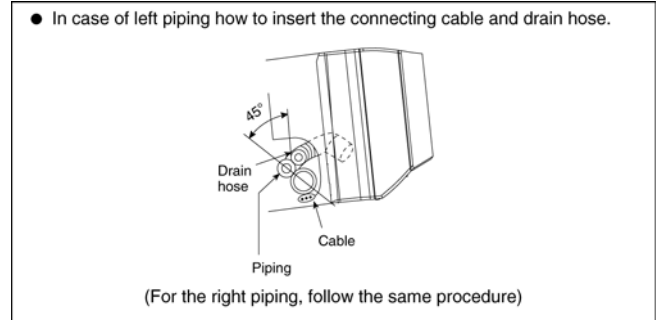
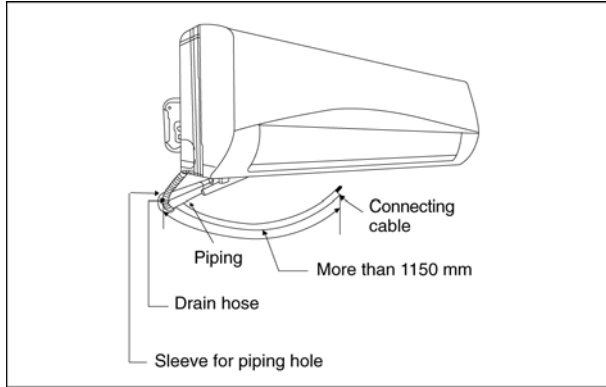
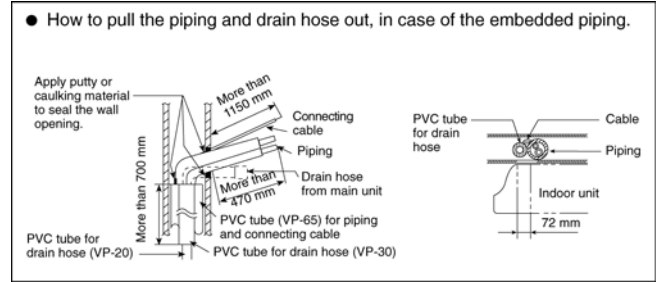
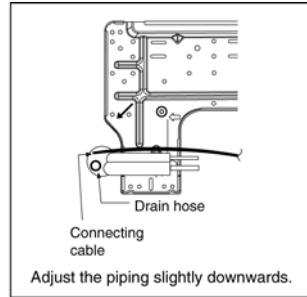
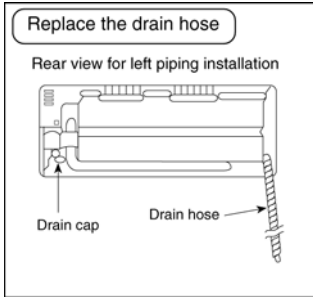

11.2.4. Connect the Cable to the Indoor Unit

1. The inside and outside connecting cable can be connected without removing the front grille.
2. **Connecting cable** between indoor unit and outdoor unit shall be approved polychloroprene sheathed 4 x 1.5 mm² flexible cord, type designation 245 IEC 57 or heavier cord.

Terminals on the indoor unit	1	2	3	
Colour of wires				
Terminals on the outdoor unit	1	2	3	

- Secure the connecting cable onto the control board with the holder (clammer).

This equipment must be properly earthed.

- Ensure the colour of wires of outdoor unit and the terminal Nos. are the same to the indoor's respectively.
- Earth wire shall be Yellow/Green (Y/G) in colour and longer than other AC wires for safety reason.

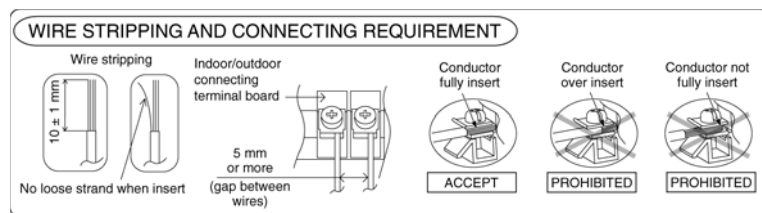
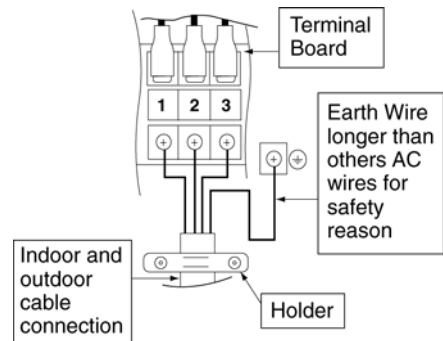

CUTTING AND FLARING THE PIPING

1. Please cut using pipe cutter and then remove the burrs.
2. Remove the burrs by using reamer. If burrs is not removed, gas leakage may be caused. Turn the piping end down to avoid the metal powder entering the pipe.
3. Please make flare after inserting the flare nut onto the copper pipes.



1. To cut

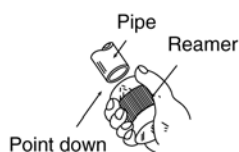

2. To remove burrs

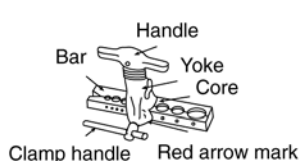

3. To flare

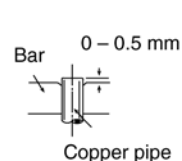

Improper flaring

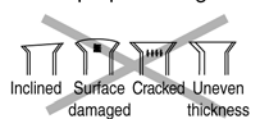

When properly flared, the internal surface of the flare will evenly shine and be of even thickness. Since the flare part comes into contact with the connections, carefully check the flare finish.

11.3. Outdoor Unit

11.3.1. Install the Outdoor Unit

- After selecting the best location, start installation according to Indoor/Outdoor Unit Installation Diagram.
- 1. Fix the unit on concrete or rigid frame firmly and horizontally by bolt nut ($\phi 10$ mm).
- 2. When installing at roof, please consider strong wind and earthquake. Please fasten the installation stand firmly with bolt or nails.

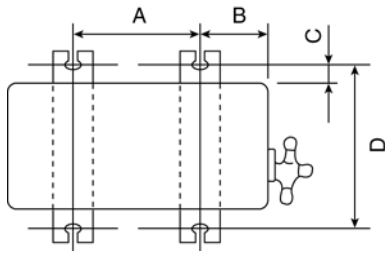

Model	A	B	C	D
E7***	570 mm	105 mm	18.5 mm	320 mm
E9***, XE9***				
E12***, XE12***				
E15***-1				
E15***, E15***-3	612.5 mm	131 mm	19 mm	383 mm
E18***, XE18***	613 mm	131 mm	16 mm	360.5 mm
E21***				
E24***, XE24***				
E28***				

11.3.2. Connect the Piping

Connecting the Piping to Indoor

Please make flare after inserting flare nut (locate at joint portion of tube assembly) onto the copper pipe.

(In case of using long piping)

Connect the piping

- Align the center of piping and sufficiently tighten the flare nut with fingers.
- Further tighten the flare nut with torque wrench in specified torque as stated in the table.

CAUTION	
Do not over tighten, over tightening cause gas leakage.	
Piping Size	Torque
1/4" (6.35 mm)	[18 N•m (1.8 kgf.m)]
3/8" (9.52 mm)	[42 N•m (4.3 kgf.m)]
1/2" (12.7 mm)	[55 N•m (5.6 kgf.m)]
5/8" (15.88 mm)	[65 N•m (6.6 kgf.m)]
3/4" (19.05 mm)	[100 N•m (10.2 kgf.m)]

Connecting the Piping to Outdoor

Decide piping length and then cut by using pipe cutter. Remove burrs from cut edge. Make flare after inserting the flare nut (located at valve) onto the copper pipe.

Align center of piping to valve and then tighten with torque wrench to the specified torque as stated in the table.

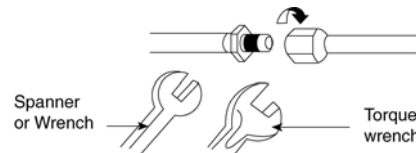

Connecting the Piping to Outdoor Multi

Decide piping length and then cut by using pipe cutter. Remove burrs from cut edge. Make flare after inserting the flare nut (located at valve) onto the copper pipe.

Align center of piping to valve and then tighten with torque wrench to the specified torque as stated in the table.

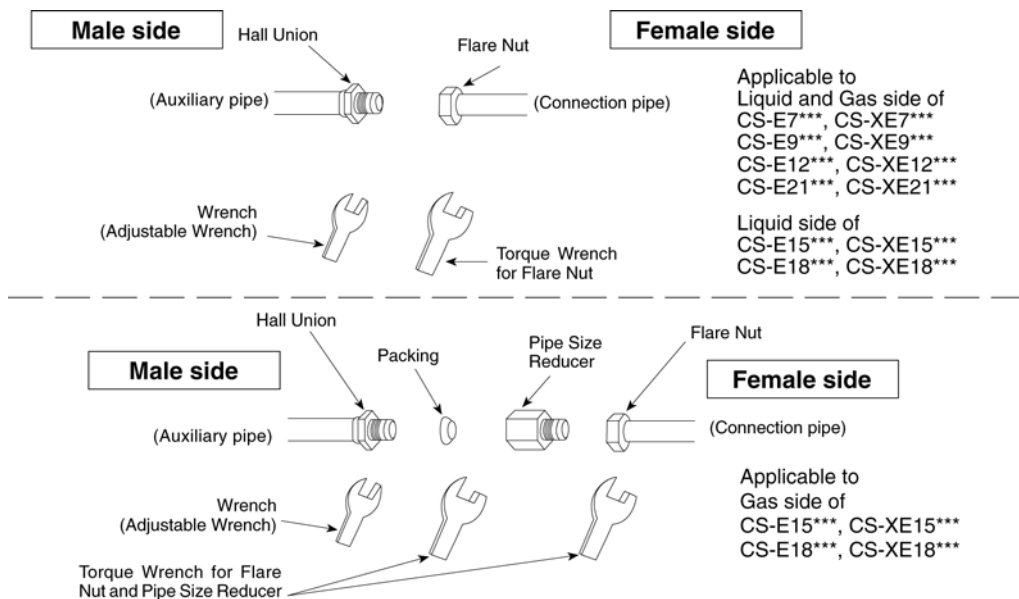

11.3.3. Evacuation of the Equipment

WHEN INSTALLING AN AIR CONDITIONER, BE SURE TO EVACUATE THE AIR INSIDE THE INDOOR UNIT AND PIPES in the following procedure.

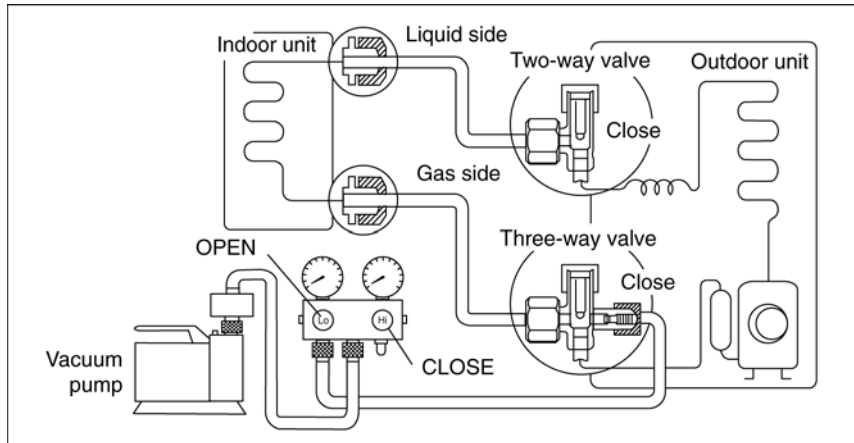

1. Connect a charging hose with a push pin to the Low side of a charging set and the service port of the 3-way valve.
 - Be sure to connect the end of the charging hose with the push pin to the service port.
2. Connect the center hose of the charging set to a vacuum pump.
3. Turn on the power switch of the vacuum pump and make sure that the needle in the gauge moves from 0 cmHg (0 MPa) to -76 cmHg (-0.1 MPa). Then evacuate the air approximately ten minutes.
4. Close the Low side valve of the charging set and turn off the vacuum pump. Make sure that the needle in the gauge does not move after approximately five minutes.

Note: BE SURE TO TAKE THIS PROCEDURE IN ORDER TO AVOID REFRIGERANT GAS LEAKAGE.
5. Disconnect the charging hose from the vacuum pump and from the service port of the 3-way valve.
6. Tighten the service port caps of the 3-way valve at a torque of 18 N•m with a torque wrench.
7. Remove the valve caps of both of the 2-way valve and 3-way valve. Position both of the valves to “OPEN” using a hexagonal wrench (4 mm).
8. Mount valve caps onto the 2-way valve and the 3-way valve.
 - Be sure to check for gas leakage.

CAUTION

- If gauge needle does not move from 0 cmHg (0 MPa) to -76 cmHg (-0.1 MPa), in step ③ above take the following measure:
 - If the leak stops when the piping connections are tightened further, continue working from step ③.
 - If the leak does not stop when the connections are retightened, repair the location of leak.
 - Do not release refrigerant during piping work for installation and reinstallation.
 - Take care of the liquid refrigerant, it may cause frostbite.

11.3.4. Connect the Cable to the Outdoor Unit

1. Remove the control board cover from the unit by loosening the screw.
2. Cable connection to the power supply through Isolating Devices (Disconnecting means).
 - Connect approved type polychloroprene sheathed **power supply cord** 3 x 1.5 mm² (3/4 ~ 1.75HP), 3 x 2.5 mm² (2.0 ~ 2.5HP) or 3 x 4.0 mm² (3.0HP) type designation 245 IEC 57 or heavier cord to the terminal board, and connect the others end of the cord to Isolating Devices (Disconnecting means).
3. **Connecting cable** between indoor unit and outdoor unit shall be approved polychloroprene sheathed 4 x 1.5 mm² flexible cord, type designation 245 IEC 57 or heavier cord.
4. Connect the power supply cord and connecting cable between indoor unit and outdoor unit according to the diagram below.

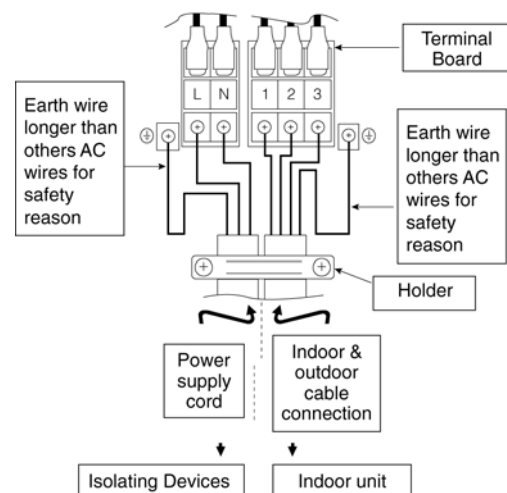

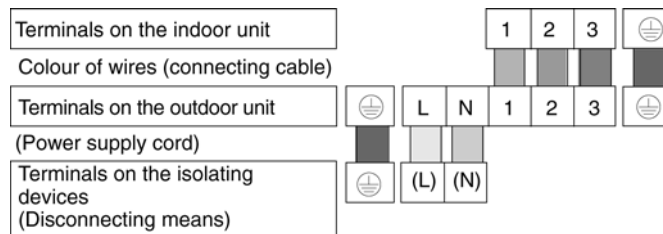

5. Secure the power supply cord and connecting cable onto the control board with the holder.
6. Attach the control board cover back to the original position with screw.
7. For wire stripping and connection requirement, refer to instruction ⑤ of indoor unit.



This equipment must be properly earthed.

- Note: Isolating Devices (Disconnecting means) should have minimum 3.0 mm contact gap.
- Earth wire shall be Yellow/Green (Y/G) in colour and longer than other AC wires for safety reason.

11.3.5. Pipe Insulation

1. Please carry out insulation at pipe connection portion as mentioned in Indoor/Outdoor Unit Installation Diagram. Please wrap the insulated piping end to prevent water from going inside the piping.
2. If drain hose or connecting piping is in the room (where dew may form), please increase the insulation by using POLY-E FOAM with thickness 6mm or above.

12 Operation and Control

12.1. Basic Function

Inverter control, which equipped with a microcomputer in determining the most suitable operating mode as time passes, automatically adjusts output power for maximum comfort always. In order to achieve the suitable operating mode, the microcomputer maintains the set temperature by measuring the temperature of the environment and performing temperature shifting. The compressor at outdoor unit is operating following the frequency instructed by the microcomputer at indoor unit that judging the condition according to internal setting temperature and intake air temperature.

12.1.1. Internal Setting Temperature

Once the operation starts, remote control setting temperature will be taken as base value for temperature shifting processes. These shifting processes are depending on the air conditioner settings and the operation environment. The final shifted value will be used as internal setting temperature and it is updated continuously whenever the electrical power is supplied to the unit.

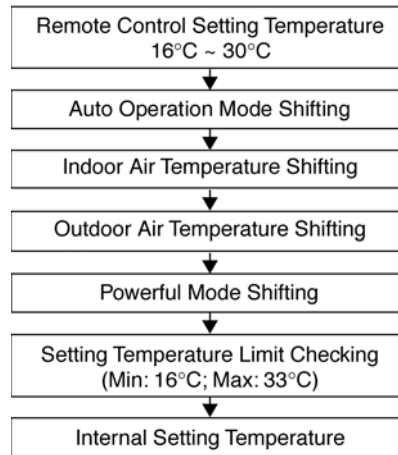

12.1.2. Cooling Operation

12.1.2.1. Thermostat control

- Compressor is OFF when Intake Air Temperature - Internal Setting Temperature < -1.5°C.
- Compressor is ON after waiting for 3 minutes, if the Intake Air Temperature - Internal Setting Temperature > Compressor OFF point.

12.1.3. Soft Dry Operation

12.1.3.1. Thermostat control

- Compressor is OFF when Intake Air Temperature - Internal Setting Temperature < -2.0°C.
- Compressor is ON after waiting for 3 minutes, if the Intake Air Temperature - Internal Setting Temperature > Compressor OFF point.

12.1.4. Heating Operation

12.1.4.1. Thermostat control

- Compressor is OFF when Intake Air Temperature - Internal Setting Temperature > +2.0°C.
- Compressor is ON after waiting for 3 minutes, if the Intake Air Temperature - Internal Setting Temperature < Compressor OFF point.

12.1.5. Automatic Operation

- This mode can be set using remote control and the operation is decided by remote control setting temperature, remote control operation mode, indoor intake air temperature and outdoor air temperature.
- During operation mode judgment, indoor fan motor (with speed of Lo-) and outdoor fan motor are running for 30 seconds to detect the indoor intake and outdoor air temperature. The operation mode is decided based on below chart.

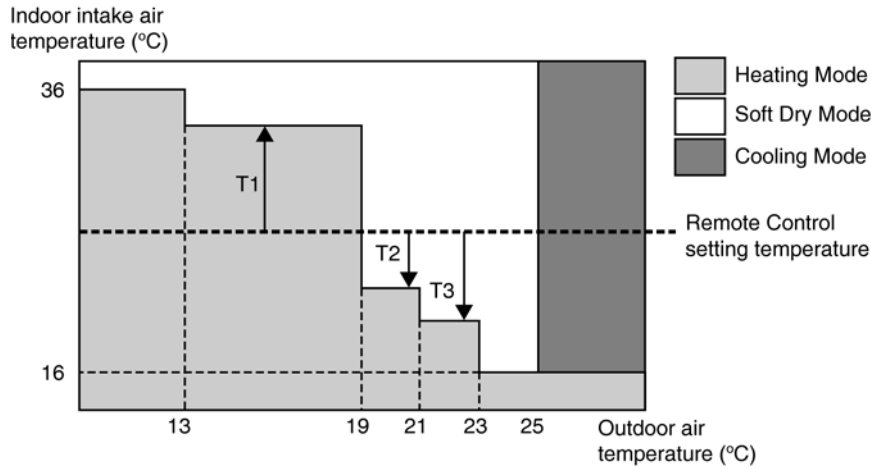

- Every 30 minutes, the indoor and outdoor temperature is judged. Based on remote control setting temperature, the value of T1 will increase up to 10°C, T2 will decrease by 3°C and T3 will decrease up to 8°C.
- The Auto Operation Mode shifting will take place whenever operation mode changed from Cool/Soft Dry to Heating or vice versa.

12.2. Indoor Fan Motor Operation

A. Basic Rotation Speed (rpm)

i. Manual Fan Speed

[Cooling, Dry]

- Fan motor's number of rotation is determined according to remote control setting.

Remote Control	O	O	O	O	O
Tab	Hi	Me+	Me	Me-	Lo

[Heating]

- Fan motor's number of rotation is determined according to remote control setting.

Remote Control	O	O	O	O	O
Tab	SHi	Me+	Me	Me-	Lo

ii. Auto Fan Speed

[Cooling, Dry]

- According to room temperature and setting temperature, indoor fan speed is determined automatically.
- The indoor fan will operate according to pattern below.

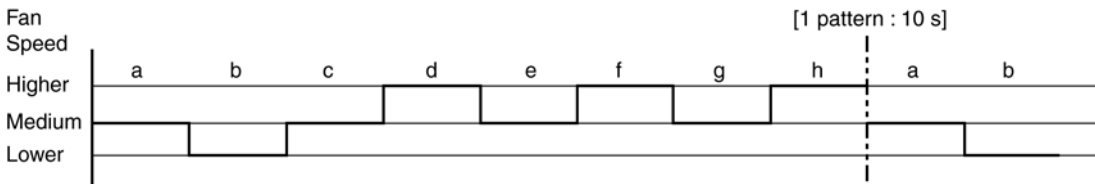

[Heating]

- According to indoor pipe temperature, automatic heating fan speed is determined as follows.

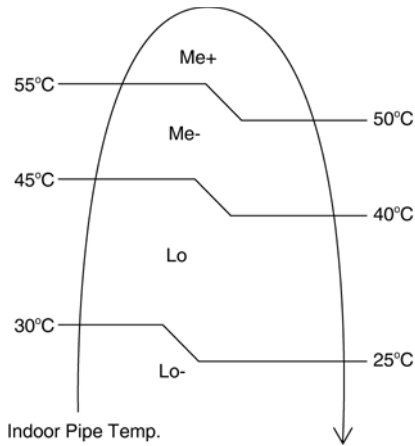

B. Feedback control

- Immediately after the fan motor started, feedback control is performed once every second.
- During fan motor on, if fan motor feedback ≥ 2550 rpm or < 50 rpm continue for 10 seconds, then fan motor error counter increase, fan motor is then stop and restart. If the fan motor counter becomes 7 times, then H19 - fan motor error is detected. Operation stops and cannot on back.

12.3. Outdoor Fan Motor Operation

Outdoor fan motor is operated with one fan speed only. It starts when compressor starts operation and it stops 30 seconds after compressor stops operation.

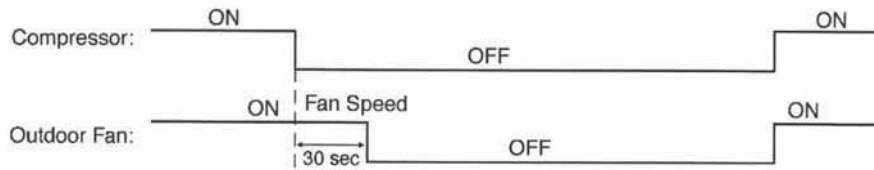

12.4. Airflow Direction

1. There are two types of airflow, vertical airflow (directed by horizontal vane) and horizontal airflow (directed by vertical vanes).
2. Control of airflow direction can be automatic (angles of direction is determined by operation mode, heat exchanger temperature and intake air temperature) and manual (angles of direction can be adjusted using remote control).

12.4.1. Vertical Airflow

Operation Mode	Airflow Direction		Vane Angle (°)				
			1	2	3	4	5
Heating	Auto with Heat Exchanger Temperature	A	20				
		B	57				
		C	32				
	Manual		20	32	45	57	68
Cooling and Ion	Auto		20 ~ 45				
	Manual		20	26	32	37	45
Soft Dry	Auto		20 ~ 45				
	Manual		20	26	32	37	45

1. Automatic vertical airflow direction can be set using remote control; the vane swings up and down within the angles as stated above. For heating mode operation, the angle of the vane depends on the indoor heat exchanger temperature as Figure 1 below. When the air conditioner is stopped using remote control, the vane will shift to close position.

2. Manual vertical airflow direction can be set using remote control; the angles of the vane are as stated above and the positions of the vane are as Figure 2 below. When the air conditioner is stopped using remote control, the vane will shift to close position.

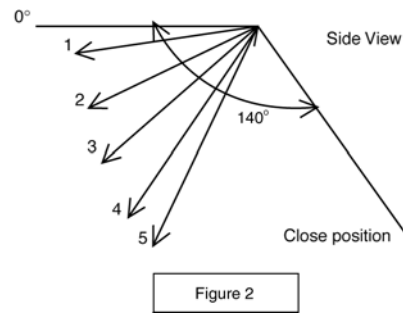
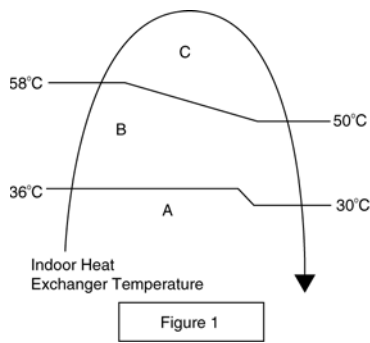

12.4.2. Horizontal Airflow

- The horizontal airflow direction louvers can be adjusted manually by hand.

12.5. Quiet operation (Cooling Mode/Cooling area of Dry Mode)

A. Purpose

To provide quiet cooling operation compare to normal operation.

B. Control condition

a. Quiet operation start condition

- When "Quiet" button at remote control is pressed.
Quiet LED illuminates.

b. Quiet operation stop condition

1. When one of the following conditions is satisfied, quiet operation stops:
 - a. Powerful button is pressed.
 - b. Stop by OFF/ON switch.
 - c. Timer "off" activates.
 - d. Quiet button is pressed again.
2. When quiet operation is stopped, operation is shifted to normal operation with previous setting.
3. When fan speed is changed, quiet operation is shifted to quiet operation of the new fan speed.
4. When operation mode is changed, quiet operation is shifted to quiet operation of the new mode.
5. During quiet operation, if timer "on" activates, quiet operation maintains.
6. After off, when on back, quiet operation is not memorised.

C. Control contents

1. Fan speed is changed from normal setting to quiet setting of respective fan speed.
This is to reduce sound of Hi, Me, Lo for 3dB (some models more than 3dB).
2. Fan speed for quiet operation is -1 step from setting fan speed.

12.6. Quiet operation (Heating)

A. Purpose

To provide quiet heating operation compare to normal operation.

B. Control condition

a. Quiet operation start condition

- When "Quiet" button at remote control is pressed.
Quiet LED illuminates.

b. Quiet operation stop condition

1. When one of the following conditions is satisfied, quiet operation stops:
 - a. Powerful button is pressed.
 - b. Stop by OFF/ON switch.
 - c. Timer "off" activates.
 - d. Quiet button is pressed again.

2. When quiet operation is stopped, operation is shifted to normal operation with previous setting.
3. When fan speed is changed, quiet operation is shifted to quiet operation of the new fan speed.
4. When operation mode is changed, quiet operation is shifted to quiet operation of the new mode, expect fan only mode.
5. During quiet operation, if timer "on" activates, quiet operation maintains.
6. After off, when on back, quiet operation is not memorised.

C. Control contents

- a. Fan Speed manual
 1. Fan speed is changed from normal setting to quiet setting of respective fan speed.
This is to reduce sound of Hi, Me, Lo for 3dB.
 2. Fan speed for quiet operation is -1 step from setting fan speed.
- b. Fan Speed Auto
 1. Indoor FM RPM depends on pipe temp sensor of indoor heat exchanger.

12.7. Powerful Mode Operation

- When the powerful mode is selected, the internal setting temperature will shift lower up to 2°C (for Cooling/Soft Dry) or higher up to 3.5°C (for Heating) than remote control setting temperature for 20 minutes to achieve the setting temperature quickly.

12.8. Timer Control

12.8.1. ON Timer Control

- ON timer can be set using remote control, the unit with timer set will start operate earlier than the setting time. This is to provide a comfortable environment when reaching the set ON time.
- 60 minutes before the set time, indoor (at fan speed of Lo-) and outdoor fan motor start operate for 30 seconds to determine the indoor intake air temperature and outdoor air temperature in order to judge the operation starting time.
- From the above judgment, the decided operation will start operate earlier than the set time as shown below.

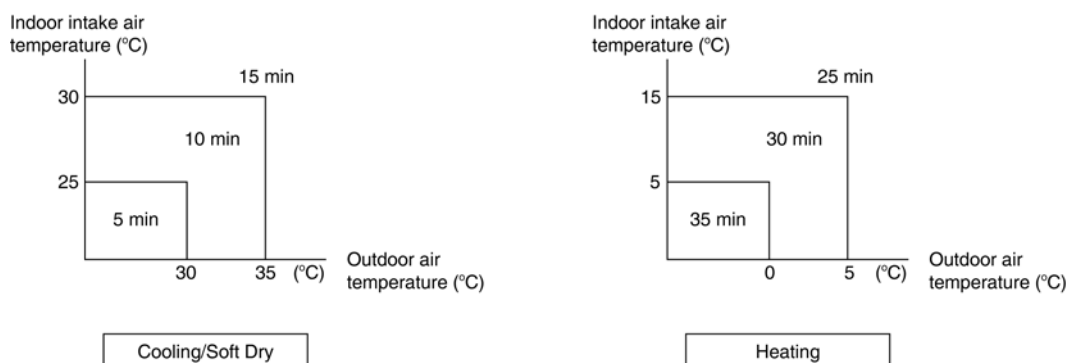

12.8.2. OFF Timer Control

OFF timer can be set using remote control, the unit with timer set will stop operate at set time.

12.9. Auto Restart Control

1. When the power supply is cut off during the operation of air conditioner, the compressor will re-operate within three to four minutes (there are 10 patterns between 2 minutes 58 seconds and 3 minutes 52 seconds to be selected randomly) after power supply resumes.
2. This type of control is not applicable during ON/OFF Timer setting.

12.10. Indication Panel

LED	POWER	TIMER	QUIET	POWERFUL	e-ion	Mild Dry Cooling	PATROL SENSOR
Color	Green	Orange	Orange	Orange	Blue	Blue	Blue
Light ON	Operation ON	Quiet Setting ON	Quiet Mode ON	Powerful Mode ON	e-ion ON	Mild Dry Cooling ON	PATROL ON
Light OFF	Operation OFF	Quiet Setting OFF	Quiet Mode OFF	Powerful Mode OFF	e-ion OFF	Mild Dry Cooling OFF	PATROL OFF

Note:

- If POWER LED is blinking, the possible operation of the unit are Hot Start, during Deice operation, operation mode judgment, or ON timer sampling.
- If Timer LED is blinking, there is an abnormality operation occurs.
- If e-ion LED is blinking, there is an abnormality of e-ion occurs.
- If PATROL LED is blinking, there is a gas sensor error detection.

12.11. Patrol Operation

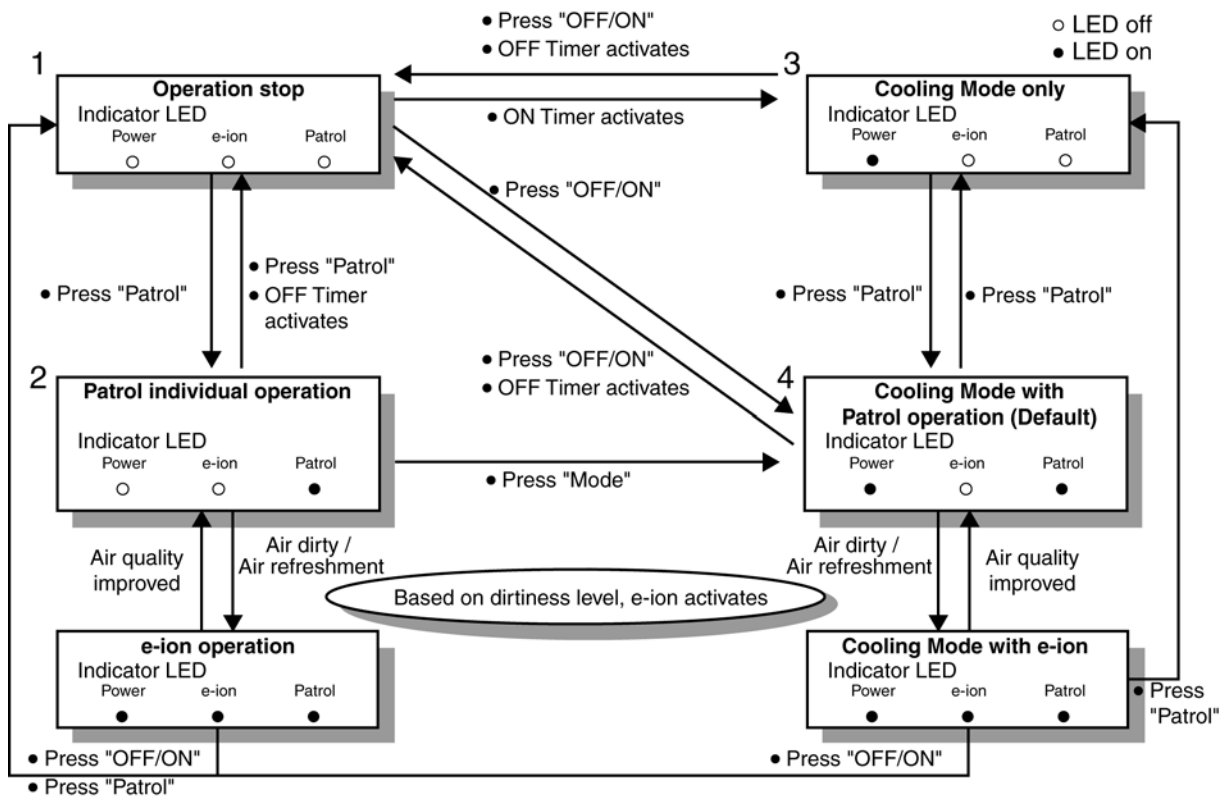

A. Purpose

To monitor air dirtiness level by using Patrol sensor and to maintain air freshness by activates e-ion operation.

B. Control Condition

a. Patrol operation start condition

- When the unit operation is started with "OFF/ON" button.
- When the unit stops, "Patrol" button is pressed, Patrol individual operation will start.
- During cooling only operation, "Patrol" button is pressed.

b. Patrol operation stop condition

When any of the following condition is fulfilled:

- When "OFF/ON" button is pressed.
- During any operation with Patrol, "Patrol" button is pressed again.
- When "e-ion" button is pressed.
- When OFF Timer activates.

c. Patrol operation disable

- To disable the Patrol Operation during unit start (default) with "OFF/ON" button, press "Patrol" button and hold for 5 seconds, then release.
- To disable the Patrol Operation, press "Patrol" button and hold for 15 seconds, then release.

C. Control Content

a. Patrol Sensor Control

- First 2 minutes from Patrol function activates is stabilization time, during stabilization time, no air dirtiness level is monitored. The Air Dirtiness level is set to level 2.
- After that, gas sensor starts to record the resistance value at fixed interval. Higher resistance value indicates cleaner air.
- The air dirtiness level is monitored by comparing the current resistance value with maximum resistance value from time to time to get the Air Dirtiness Value.
- There are 3 air dirtiness levels, based on the Air Dirtiness Value:
 - Air Dirtiness level 0: Clean
 - Air Dirtiness level 1: Moderate
 - Air Dirtiness level 2: Contaminated

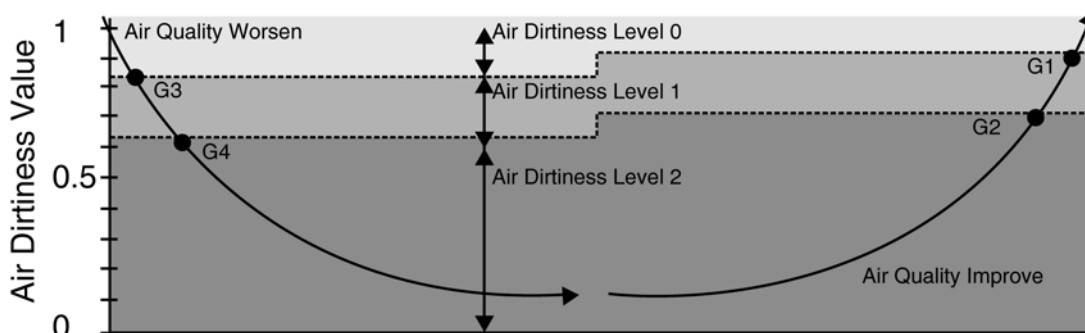

• Dirtiness level sensitivity adjustment

It is possible to change the gas sensor sensitivity, where the Threshold value (G1 ~ G4) will be shifted accordingly:

1. Press and release "SET" button.
2. Press "Timer increment" / "Timer decrement" button to select sensitivity. (Low ↔ Standard (Default) ↔ High)
3. Confirm setting by pressing "Timer Set" button. LCD returned to original display after 2 seconds.
4. LCD returned to original display if remote control does not operate for 30 seconds.

b. e-ion Control

- When dirtiness level is 1 or 2, e-ion operation starts.
- If dirtiness level improves from level 2 to level 1, the unit carries out level change after 60 seconds.
- When dirtiness level returns to level 0 continuously for 10 minutes or more, e-ion operation stops.

Dirtiness Level Shift

- For Auto Fan Speed, the fan speed increased based on dirtiness level:

	Dirtiness level	rpm shift	
		Patrol individual operation	Combine operation
e-ion ON	Dirtiness level 0	No change	No change
	Dirtiness level 1	+ 20	+ 20
	Dirtiness level 2	+ 40	+ 40

c. Indoor Fan Control

- During any operation mode combines with Patrol operation, fan speed follows respective operation mode.
- During Patrol individual operation if e-ion starts, only Auto Fan Speed and no Powerful operation is allowed. Even if "Fan Speed" button is pressed, no signal is sent to air conditioner, and no change on LCD display.
- During Patrol individual operation if e-ion stops, Indoor Fan stop operation.

d. Airflow direction (Horizontal, Vertical) Control

- During any operation mode combines with Patrol operation, airflow direction follows respective operation mode.
- During Patrol individual operation if e-ion starts, only Auto Air Swing is allowed. Even if "Air Swing" button is pressed, no signal is sent to air conditioner, and no change on LCD display.
- During Patrol individual operation if e-ion stops, Airflow direction louver closed.

e. Indicator

- When Patrol operation starts, Patrol Sensor indicator ON.
- When e-ion operation starts based on dirtiness level, e-ion indicator ON.

f. Remote Control Receiving Sound

- Normal Operation → Patrol Mode : Beep
- Patrol Mode → Stop : Long Beep
- Patrol Mode → Normal Operation : Beep
- Stop → Patrol : Beep

g. Timer Control

- When ON timer activates when unit stops, previous operation resumes and restored last saved patrol operation status.
- When ON timer activates during any operation, no change and carry on current operation.
- When OFF timer activates during any operation, all operation stops and the latest patrol operation status is saved.

h. Power failure

- During Patrol individual operation, if power failure occurs, after power resumes, Patrol individual operation resumes immediately.
- During combination operation, if power failure occurs, after power resumes combination operation resume immediately.

i. Error Detection Control

- The Patrol error detection control starts once the power is supplied to Patrol sensor. However, the error will display when the Patrol operation is ON.
- Error detection method:
 - If the Patrol sensor feedback is 0V or 5V continuous for 6 hours, Patrol sensor error occurs. However, the error will display only when the Patrol operation is ON.
- Patrol Sensor Control after error occurs
 - During any operation mode combines with Patrol operation
 - Power supply to Patrol sensor is OFF
 - Air conditioner normal mode operation continues with Patrol LED and Timer LED blinking and "H58" is indicated.
 - Timer LED will always blinking and the Patrol LED continues blinking if the Patrol operation is ON and stops blinking if the patrol operation is OFF.
 - During Patrol individual mode
 - Power supply to Patrol sensor is OFF
 - Patrol LED and Timer LED blinking and "H58" is indicated.
 - Timer LED will always blinking and the Patrol LED continues blinking if the Patrol operation is ON and stops blinking if the Patrol operation is OFF.
- Error cancel condition:
 - Power supply reset

12.12. e-ion Operation

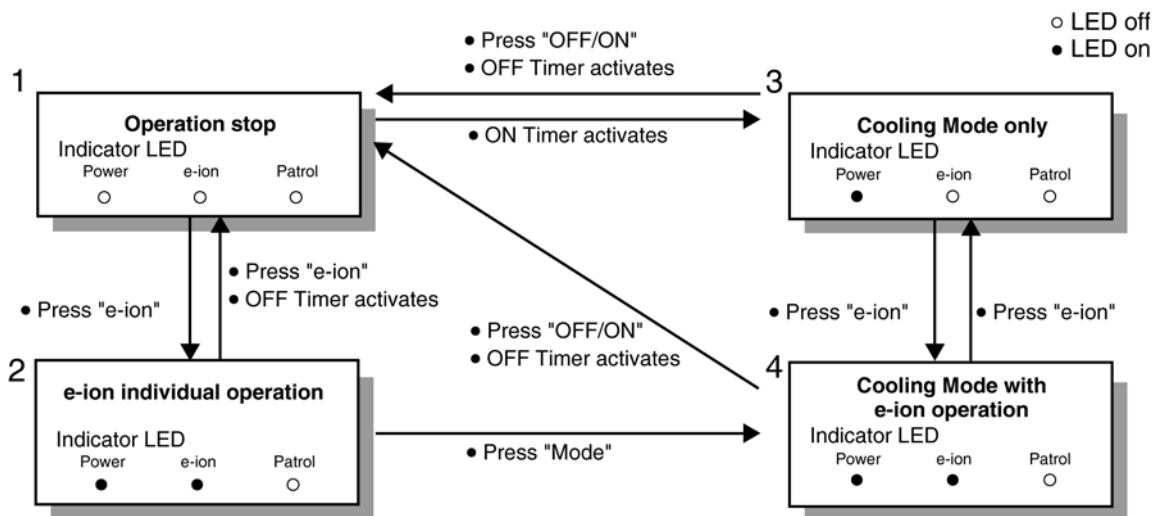

A. Purpose

This operation provides clean air by producing negative ions to attract dust captured at the positively charged e-ion filters.

B. Control Condition

a. e-ion operation start condition

- During unit running at any operation mode, if “e-ion” button is pressed, combination operation (operation mode + e-ion operation) starts.
- During unit is OFF, if “e-ion” button is pressed, e-ion individual operation starts.

b. e-ion operation stop condition

- When “OFF/ON” button is pressed to stop the operation.
- When “e-ion” button is pressed again.
- When “Patrol” button is pressed.
- When OFF Timer activates.

c. e-ion operation pause condition

- When indoor fan stop (during deice, odor cut control, thermostat off, etc.). e-ion operation resume after indoor fan restarts.
- When indoor intake temperature $\geq 40^{\circ}\text{C}$. e-ion operation resume after indoor intake temperature $< 40^{\circ}\text{C}$ continuously for 30 minutes.

C. Control Content

a. Indoor fan control

- During any operation mode combines with e-ion operation, fan speed follows respective operation mode.
- During e-ion individual operation - only Auto Fan Speed and no Powerful operation is allowed. Even if Fan Speed button is pressed, no signal is sent to air conditioner, and no change on LCD display.

Auto Fan Speed for e-ion operation switches between HLo and CLo at pattern below:

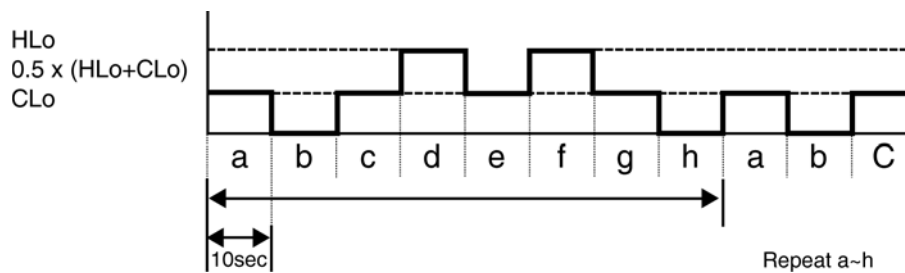

b. Airflow direction control

- During any operation mode combines with e-ion operation, airflow direction follows respective operation mode.
- During e-ion individual operation, only Auto Air Swing is allowed. Even if Air Swing button is pressed, no signal is sent to air conditioner, and no change on LCD display.

c. Timer control

- When ON timer activates when unit stops, previous operation resumes and restores last saved e-ion operation status.
- When ON timer activates during any operation, no change and carry on current operation.
- When OFF timer activates during any operation, all operation stops and the latest e-ion operation status is saved.

d. Indicator

- When e-ion operation starts, e-ion indicator ON.

e. e-ion Check Mode

- To check if e-ion is malfunctioning, press “e-ion” button and follow by “Check” button to enter e-ion check mode and supplies power to the e-ion Air Purifying System.
- If abnormal discharge is detected at filter (short-circuited) due to water or dust adhesion, etc., the e-ion indicator blinks immediately.

f. Power failure

- During e-ion individual operation, if power failure occurs, after power resumes, e-ion individual operation resumes immediately.
- During combination operation, if power failure occurs, after power resumes, combination operation resume immediately.

g. Error Detection Control

When e-ion indicator blink, it indicates error listed below:

i. e-ion Air Purifying system main connector to PCB is open:

Judgement Method

- During e-ion operation (include during Patrol operation), e-ion Air Purifying system main connector to PCB is opened.

Troubleshooting Methods

- Connect the connector or stop operation (include during Patrol operation) to cancel the blinking.

ii. Abnormal Discharge

Judgement Method

- During e-ion operation, when feedback voltage is -Lo (at microcontroller) is detected, it is judged abnormal discharge and stops power supplies to the e-ion Air Purifying system.
- The unit retries after 30 minutes and repeat for 24 times. (not applicable for e-ion Check Mode)

Troubleshooting Method

- Press “e-ion” button or “OFF/ON” button to stop the operation and check the e-ion Air Purifying system main connector to PCB.
- After that, press “e-ion” button again to confirm the e-ion indicator not blinking.
- The 24 times counter will be clear after 10 minutes of normal operation or when operation stops.

Error Reset Method

- Press “OFF/ON” button to OFF the operation.
- Press AUTO OFF/ON button at indoor unit to OFF the operation.
- OFF Timer activates.
- Press “e-ion” button during e-ion individual mode.
- Power supply reset.

iii. e-ion breakdown

Judgement Method

- When hi-feedback voltage (at microcontroller) supplied to filter during e-ion stop, due to PCB or filter's high voltage power supply damage.
- Operations except e-ion continue. Both Timer indicator and e-ion indicator blink.

Troubleshooting Method

- Press “e-ion” button or “OFF/ON” button to stop the operation.
- Change main circuit board or filter's high voltage power supply.
- When lo-feedback voltage supplied to e-ion Air Purifying system during e-ion operation, e-ion indicator and Timer indicator stop blinking.

12.13. Mild Dry Cooling Operation

- This operation helps to prevent decreases in room humidity while maintaining the setting temperature.
- During unit running at Cooling operation mode, if “Mild Dry Cooling” button is pressed, Mild Dry Cooling operation starts and Mild Dry Cooling indicators turns ON.
- Mild dry cooling operation is unavailable when the unit is operating Auto mode, Soft Dry mode, Patrol individual operation or e-ion individual operation.
- Mild dry cooling operation is cancelled when the unit turned OFF, or when the operation mode changed from Cooling to other mode.
- Powerful, Quiet and Mild Dry Cooling mode cannot function at the same time, the unit will follows the operation according to the last signal received.
- During this operation, the compressor frequency changes according to operating condition to prevent room humidity decreases and when AUTO AIR SWING is set, the vertical airflow direction fixed at lower limit position.

13 Protection Control

13.1. Protection Control For All Operations

13.1.1. Restart Control (Time Delay Safety Control)

- The Compressor will not turn on within 3 minutes from the moment operation stops, although the unit is turned on again by pressing OFF/ON button at remote control within this period.
- This control is not applicable if the power supply is cut off and on again.
- This phenomenon is to balance the pressure inside the refrigerant cycle.

13.1.2. 30 Seconds Forced Operation

- Once the air conditioner is turned on, the compressor will not stop within 30 seconds in a normal operation although the intake air temperature has reached the thermo-off temperature. However, force stop by pressing the OFF/ON button at the remote control is permitted or the Auto OFF/ON button at indoor unit.
- The reason for the compressor to force operation for minimum 30 seconds is to allow the refrigerant oil run in a full cycle and return back to the outdoor unit.

13.1.3. Total Running Current Control

1. When the outdoor unit total running current (AC) exceeds X value, the frequency instructed for compressor operation will be decreased.
2. If the running current does not exceed X value for 5 seconds, the frequency instructed will be increased.
3. However, if total outdoor unit running current exceeds Y value, compressor will be stopped immediately for 3 minutes.

Model	E7JK		E9JK		E12JK		E15JK-1		E15JKE	
	X (A)	Y (A)	X (A)	Y (A)	X (A)	Y (A)	X (A)	Y (A)	X (A)	Y (A)
Cooling/Soft Dry (A)	3.95	15.0	4.54	15.0	6.86	15.0	7.52	15.0	9.0	15.0
Cooling/Soft Dry (B)	3.6	15.0	4.12	15.0	6.35	15.0	7.16	15.0	8.5	15.0
Heating	4.37	15.0	5.57	15.0	8.03	15.0	8.55	15.0	9.8	15.0

4. The first 30 minutes of cooling operation, (A) will be applied.

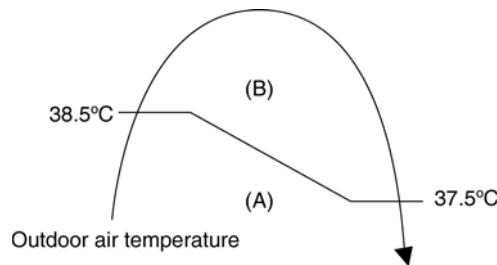

13.1.4. IPM (Power transistor) Prevention Control

A. Overheating Prevention Control

1. When the IPM temperature rises to 100°C, compressor operation will stop immediately.
2. Compressor operation restarts after 3 minutes the temperature decreases to 95°C.
3. If this condition repeats continuously 4 times within 20 minutes, timer LED will be blinking ("F96" is indicated).

B. DC Peak Current Control

1. When electric current to IPM exceeds set value of 18.5 A, the compressor will stop operate. Then, operation will restart after 3 minutes.
2. If the set value is exceeded again more than 30 seconds after the compressor starts, the operation will restart after 2 minutes.
3. If the set value exceeded again within 30 seconds after the compressor starts, the operation will restart after 1 minute. If this condition repeats continuously for 7 times, all indoor and outdoor relays will be cut off, timer LED will be blinking ("F99" is indicated).

13.1.5. Compressor Overheating Prevention Control

- Instructed frequency for compressor operation will be regulated by compressor discharge temperature. The changes of frequency are as below.
- If compressor discharge temperature exceeds 110°C, compressor will be stopped, occurs 4 times per 20 minutes, timer LED will be blinking. ("F97" is indicated.)

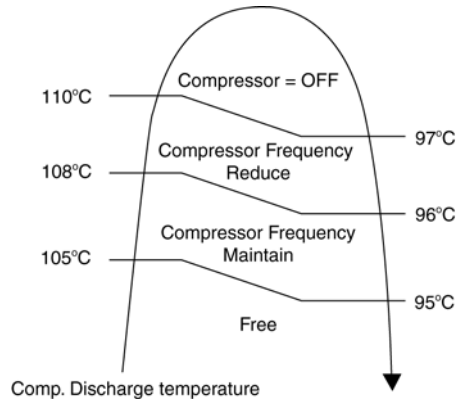

13.1.6. Low Pressure Prevention Control (Gas Leakage Detection)

- a. Control start conditions
 - For 5 minutes, the compressor continuously operates and outdoor total current is between 0.65A and 1.65A.
 - During Cooling and Soft Dry operations:
Indoor suction temperature - indoor piping temperature is below 4°C.
 - During Heating operations :
Indoor piping temperature - indoor suction is under 5°C.
- b. Control contents
 - Compressor stops (and restart after 3 minutes).
 - If the conditions above happen 2 times within 20 minutes, the unit will:
 - Stop operation
 - Timer LED blinks and "F91" indicated.

13.1.7. Compressor Tank Temperature Rise Protection Control

- a. Control start conditions
 - For 5 minutes, the compressor continuously operates and outdoor total current is between 0.65A and 1.65A.
 - During Cooling and Soft Dry operations:
Indoor suction temperature - indoor piping temperature is below 4°C.
Indoor temperature and outdoor temperature is $30 \pm 5^\circ\text{C}$.
Remote Control setting 16°C and Hi Fan Speed.
 - During Heating operations:
Indoor piping temperature - indoor suction is under 5°C.
Indoor temperature and outdoor temperature is $20 \pm 2^\circ\text{C}$.
Remote control setting 30°C and Hi Fan Speed.
- b. Control contents
 - Compressor stops (and restart after 3 minutes)
 - If the conditions above happen 2 times within 20 minutes, the unit will:
 - Stop operation
 - Timer LED blinks and "F91" indicated

13.1.8. Low Frequency Protection Control 1

- When the compressor operate at frequency lower than 24 Hz continued for 20 minutes, the operation frequency will be changed to 23 Hz for 2 minutes.

13.1.9. Low Frequency Protection Control 2

- When all the below conditions comply, the compressor frequency will change to lower frequency.

Temperature, T, for:	Cooling/Soft Dry	Heating
Indoor intake air (°C)	$T < 15$ or $T \geq 30$	—
Outdoor air (°C)	$T < 16$ or $T \geq 38$	$T < 4$ or $T \geq 24$
Indoor heat exchanger (°C)	$T < 30$	$T \geq 0$

13.2. Protection Control For Cooling & Soft Dry Operation

13.2.1. Outdoor Air Temperature Control

- The compressor operating frequency is regulated in accordance to the outdoor air temperature as shown in the diagram below.
- This control will begin 1 minute after the compressor starts.
- Compressor frequency will adjust base on outdoor air temperature.

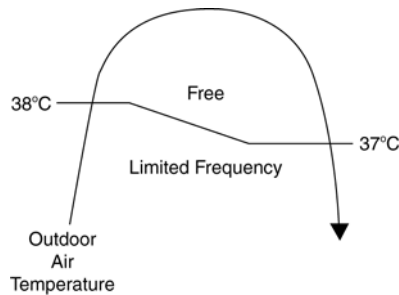

13.2.2. Cooling Overload Control

- Detects the Outdoor pipe temperature and carry out below restriction/limitation (Limit the compressor Operation frequency)
- The compressor stop if outdoor pipe temperature exceeds 61°C
- If the compressor stops 4 times in 20 minutes, Timer LED blinking (F95 indicated: outdoor high pressure rise protection)

13.2.3. Freeze Prevention Control 1

1. When indoor heat exchanger temperature is lower than 0°C continuously for 6 minutes, compressor will stop operating.
2. Compressor will resume its operation 3 minutes after the indoor heat exchanger is higher than 13°C.
3. At the same time, indoor fan speed will be higher than during its normal operation.
4. If indoor heat exchanger temperature is higher than 13°C for 5 minutes, the fan speed will return to its normal operation.

13.2.4. Freeze Prevention Control 2

1. Control start conditions
 - During Cooling operation and soft dry operation
 - During thermo OFF condition, indoor intake temperature is less than 10°C or
 - Compressor stops for freeze prevention control
 - Either one of the conditions above occurs 5 times in 60 minutes.
2. Control contents
 - Operation stops
 - Timer LED blinks and “H99” indicated

13.2.5. Dew Prevention Control 1

- To prevent dew formation at indoor unit discharge area.
- This control will be activated if:
 - Outdoor air temperature and Indoor pipe temperature judgment by microcontroller is fulfilled.
 - When Cooling or Dry mode is operated more than 20 minutes or more.
- This control stopped if:
 - Compressor stopped.
 - Remote control setting changed (fan speed / temperature).
 - Outdoor air temperature and indoor intake temperature changed.
- Fan speed, angle of louver (vertical airflow angle) will be adjusted accordingly in this control.
 - Fan speed will be increased slowly if the unit is in quiet mode but no change in normal cooling mode.

13.2.6. Dew Prevention Control 2

- To prevent dew formation at indoor unit discharge area.
- This control starts if all conditions continue for 20 minutes:
 - Operated with Cooling or Soft Dry Mode.
 - Indoor intake temperature is between 25°C and 29°C.
 - Outdoor air temperature is less than 30°C.
 - Quiet Lo fan speed.
- This control stopped if:
 - When receive air swing change signal from Remote Control.
- The horizontal louver will be fixed at 26° (regardless of Auto or Manual Airflow Direction Setting).

13.3. Protection Control For Heating Operation

13.3.1. Intake Air Temperature Control

Compressor will operate at Max freq. if either one of the below conditions occur:

1. When the indoor intake air temperature is 30°C or above.

13.3.2. Outdoor Air Temperature Control

- The Max current value is regulated when the outdoor air temperature rise above 16°C in order to avoid compressor overloading.

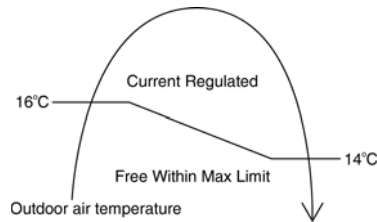

13.3.3. Overload Protection Control

- The compressor operating frequency is regulated in accordance to indoor heat exchanger temperature as shown below.
- If the heat exchanger temperature exceeds 60°C, compressor will stop.

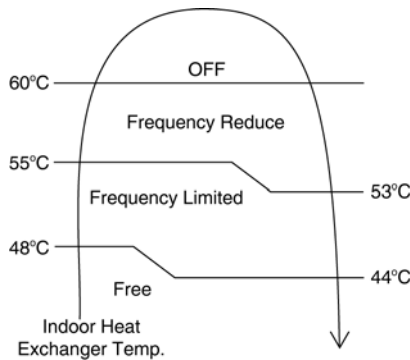

13.3.4. Low Temperature Compressor Oil Return Control

- In heating operation, if the outdoor temperature falls below -10°C when compressor starts, the compressor frequency will be regulated up to 600 seconds.

13.3.5. Cold Draught Prevention Control

- When indoor pipe temperature is low, cold draught operation starts where indoor fan speed will be reduced.

13.3.6. Deice Operation

- When outdoor pipe temperature and outdoor air temperature is low, deice operation start where indoor fan motor and outdoor fan motor stop and operation LED blinks.

14 Servicing Mode

14.1. Auto OFF/ON Button

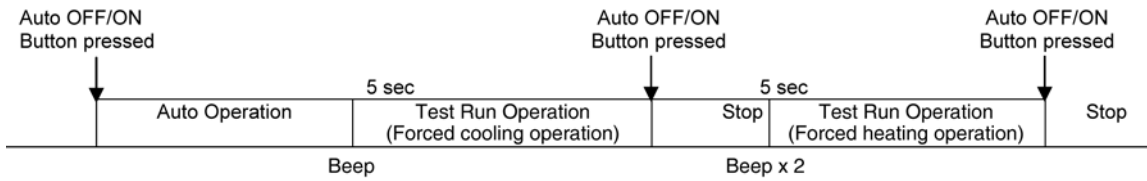

1. AUTO OPERATION MODE

The Auto operation will be activated immediately once the Auto OFF/ON button is pressed. This operation can be used to operate air conditioner with limited function if remote control is misplaced or malfunction.

2. TEST RUN OPERATION (FOR PUMP DOWN/SERVICING PURPOSE)

The Test Run operation will be activated if the Auto OFF/ON button is pressed continuously for more than 5 seconds. A “beep” sound will heard at the fifth seconds, in order to identify the starting of Test Run operation (Forced cooling operation). Within 5 minutes after Forced cooling operation start, the Auto OFF/ON button is pressed for more than 5 seconds. A 2 “beep” sounds will heard at the fifth seconds, in order to identify the starting of Forced heating operation.

The Auto OFF/ON button may be used together with remote control to set / change the advance setting of air conditioner operation.

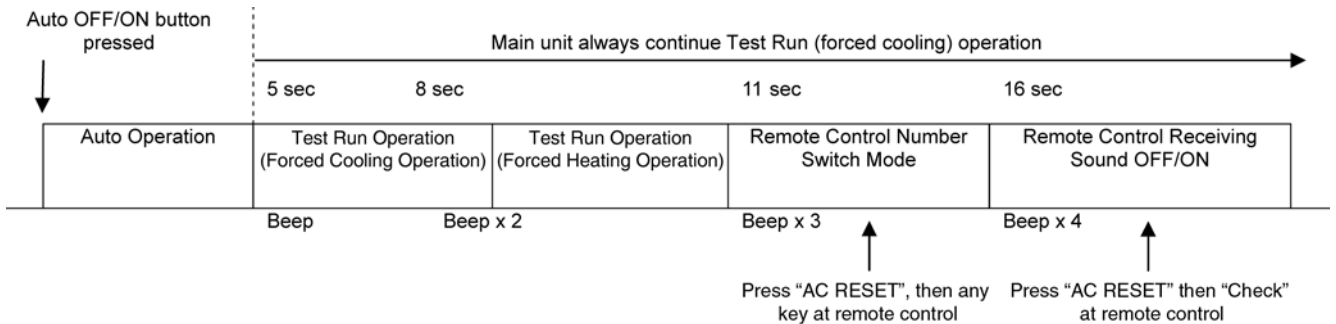

3. REMOTE CONTROL NUMBER SWITCH MODE

The Remote Control Number Switch Mode will be activated if the Auto OFF/ON button is pressed continuously for more than 11 seconds (3 “beep” sounds will occur at 11th seconds to identify the Remote Control Number Switch Mode is in standby condition) and press “AC RESET” button and then press any button at remote control to transmit and store the desired transmission code to the EEPROM.

There are 4 types of remote control transmission code could be selected and stored in EEPROM of indoor unit. The indoor unit will only operate when received signal with same transmission code from remote control. This could prevent signal interference when there are 2 or more indoor units installed nearby together.

To change remote control transmission code, short or open jumpers at the remote control printed circuit board.

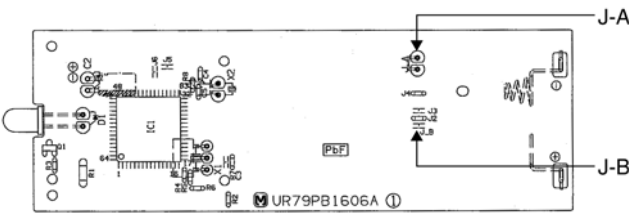

Remote Control Printed Circuit Board		
Jumper A (J-A)	Jumper B (J-B)	Remote Control No.
Short	Open	A (Default)
Open	Open	B
Short	Short	C
Open	Short	D

- During Remote Control Number Switch Mode, press any button at remote control to transmit and store the transmission code to the EEPROM.

4. REMOTE CONTROL RECEIVING SOUND OFF/ON MODE

The Remote Control Receiving Sound OFF/ON Mode will be activated if the Auto OFF/ON button is pressed continuously for more than 16 seconds (4 "beep" sounds will occur at 16th seconds to identify the Remote Control Receiving Sound Off/On Mode is in standby condition) and press "AC Reset" button and then press "Check" button at remote control.

Press "Auto OFF/ON button" to toggle remote control receiving sound.

- Short "beep": Turn OFF remote control receiving sound.
- Long "beep": Turn ON remote control receiving sound.

After Auto OFF/ON Button is pressed, the 20 seconds counter for Remote Control Receiving Sound OFF/ON Mode is restarted.

14.2. Remote Control Button

14.2.1. SET BUTTON

- To check remote control transmission code and store the transmission code to EEPROM
 - Press "SET" button for more than 10 seconds by using pointer.
 - Press "TIMER SET" button until a "beep" sound is heard as confirmation of transmission code changed.
- To change the air quality sensor sensitivity
 - Press and release by using pointer.
 - Press the Timer Decrement button to select sensitivity:
 1. Low Sensitivity
 2. Standard (Default)
 3. Hi Sensitivity
 - Confirm setting by pressing Timer Set button, a "Beep" sound will be heard. LCD returns to original display after 2 seconds.
 - LCD returns to original display if remote control does not operate for 30 seconds.

14.2.2. CLOCK BUTTON

- To change the remote control's time format
 - Press for more than 5 seconds.

14.2.3. RESET (RC)

- To clear and restore the remote control setting to factory default
 - Press once to clear the memory.

14.2.4. RESET (AC)

- To restore the unit's setting to factory default
 - Press once to restore the unit's setting.

14.2.5. TIMER ▲

- To change indoor unit indicator's LED intensity
 - Press continuously for 5 seconds.

14.2.6. TIMER ▼

- To change remote control display from Degree Celsius (°C) to Degree Fahrenheit (°F).
 - Press continuously for 10 seconds.

15 Troubleshooting Guide

15.1. Refrigeration Cycle System

In order to diagnose malfunctions, make sure that there are no electrical problems before inspecting the refrigeration cycle. Such problems include insufficient insulation, problem with the power source, malfunction of a compressor and a fan. The normal outlet air temperature and pressure of the refrigeration cycle depends on various conditions, the standard values for them are shown in the table on the right.

Normal Pressure and Outlet Air Temperature (Standard)

	Gas pressure MPa (kg/cm ² G)	Outlet air temperature (°C)
Cooling Mode	0.9 ~ 1.2 (9 ~ 12)	12 ~ 16
Heating Mode	2.3 ~ 2.9 (23 ~ 29)	36 ~ 45

- ★ Condition:
- Indoor fan speed; High
 - Outdoor temperature 35°C at cooling mode and 7°C at heating mode.
 - Compressor operates at rated frequency

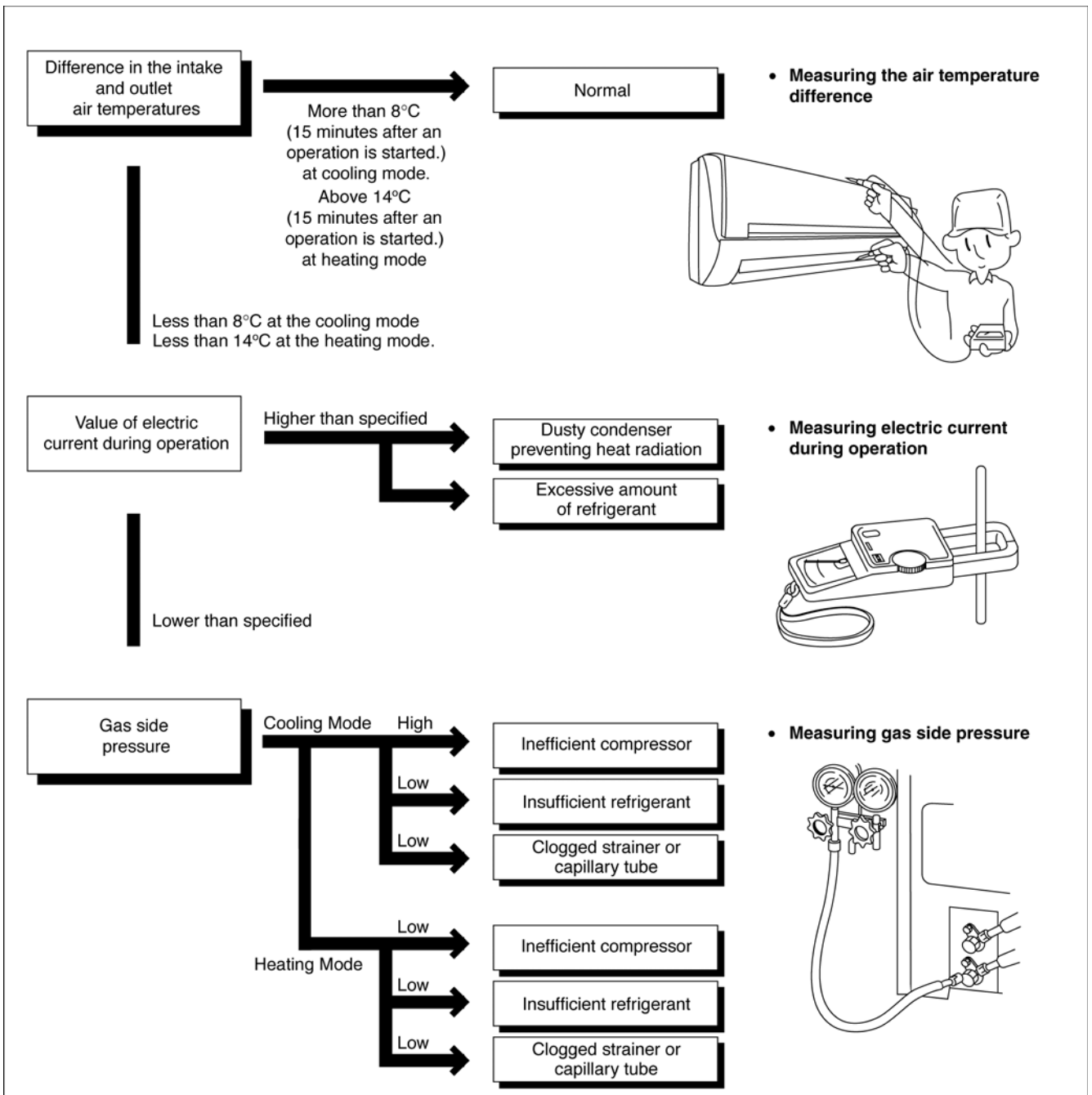

15.1.1. Relationship between the condition of the air conditioner and pressure and electric current

Condition of the air conditioner	Cooling Mode			Heating Mode		
	Low Pressure	High Pressure	Electric current during operating	Low Pressure	High Pressure	Electric current during operating
Insufficient refrigerant (gas leakage)	↘	↘	↘	↘	↘	↘
Clogged capillary tube or Strainer	↘	↘	↘	↗	↗	↗
Short circuit in the indoor unit	↘	↘	↘	↗	↗	↗
Heat radiation deficiency of the outdoor unit	↗	↗	↗	↘	↘	↘
Inefficient compression	↗	↘	↘	↗	↘	↘

- Carry out the measurements of pressure, electric current, and temperature fifteen minutes after an operation is started.

15.2. Breakdown Self Diagnosis Function

15.2.1. Self Diagnosis Function (Three Digits Alphanumeric Code)

- Once abnormality has occurred during operation, the unit will stop its operation, and Timer LED blinks.
- Although Timer LED goes off when power supply is turned off, if the unit is operated under a breakdown condition, the LED will light up again.
- In operation after breakdown repair, the Timer LED will no more blink. The last error code (abnormality) will be stored in IC memory.

• To make a diagnosis

1. Timer LED start to blink and the unit automatically stops the operation.
2. Press the CHECK button on the remote controller continuously for 5 seconds.
3. “- -” will be displayed on the remote controller display. Note: Display only for “- -”. (No transmitting signal, no receiving sound and no Power LED blinking.)
4. Press the “TIMER” ▲ or ▼ button on the remote controller. The code “H00” (no abnormality) will be displayed and signal will be transmitted to the main unit.
5. Every press of the button (up or down) will increase abnormality numbers and transmit abnormality code signal to the main unit.
6. When the latest abnormality code on the main unit and code transmitted from the remote controller are matched, power LED will light up for 30 seconds and a beep sound (continuously for 4 seconds) will be heard. If no codes are matched, power LED will light up for 0.5 seconds and no sound will be heard.
7. The breakdown diagnosis mode will be canceled unless pressing the CHECK button continuously for 5 seconds or operating the unit for 30 seconds.
8. The LED will be off if the unit is turned off or the RESET button on the main unit is pressed.

• To display memorized error (Protective operation) status

1. Turn power on.
2. Press the CHECK button on the remote controller continuously for 5 seconds.
3. “- -” will be displayed on the remote controller display. Note: Display only for “- -”. (No transmitting signal, no receiving sound and no Power LED blinking.)
4. Press the “TIMER” ▲ or ▼ button on the remote controller. The code “H00” (no abnormality) will be displayed and signal will be transmitted to the main unit. The power LED lights up. If no abnormality is stored in the memory, three beeps sound will be heard.
5. Every press of the button (up or down) will increase abnormality numbers and transmit abnormality code signal to the main unit.
6. When the latest abnormality code on the main unit and code transmitted from the remote controller are matched, power LED will light up for 30 seconds and a beep sound (continuously for 4 seconds) will be heard. If no codes are matched, power LED will light up for 0.5 seconds and no sound will be heard.

7. The breakdown diagnosis mode will be canceled unless pressing the CHECK button continuously for 5 seconds or operating the unit for 30 seconds.
8. The same diagnosis can be repeated by turning power on again.

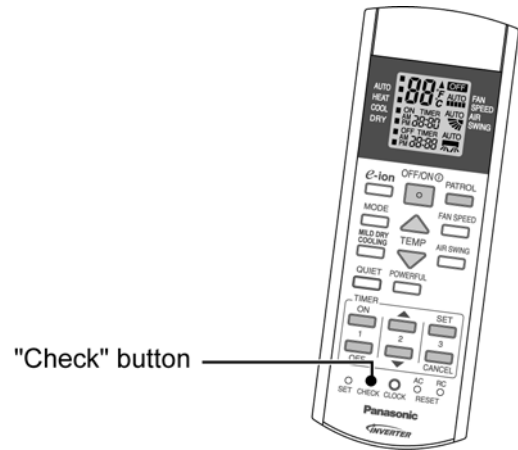

• To clear memorized error (Protective operation) status after repair:

1. Turn power on (in standby condition).
2. Press the AUTO button for 5 seconds (A beep receiving sound) on the main unit to operate the unit at Forced Cooling Operation modes.
3. Press the CHECK button on the remote controller for about 1 second with a pointed object to transmit signal to main unit. A beep sound is heard from main unit and the data is cleared.

• Temporary Operation (Depending on breakdown status)

1. Press the AUTO button (A beep receiving sound) on the main unit to operate the unit. (Remote control will become possible.)
2. The unit can temporarily be used until repaired.

Error Code	Operation	Temporary items
H23	Cooling	Emergency Operation with limited power
H27, H28	Cooling, Heating	

15.3. Error Codes Table

Diagnosis display	Abnormality / Protection control	Abnormality Judgement	Emergency operation	Primary location to verify
H00	No abnormality detected	—	Normal operation	—
H11	Indoor / outdoor abnormal communication	> 1 min after starting operation	Indoor fan operation only	<ul style="list-style-type: none"> • Internal / external cable connections • Indoor / Outdoor PCB
H12	Indoor unit capacity unmatched	—	—	—
H14	Indoor intake air temperature sensor abnormality	Continue for 5 sec.	—	<ul style="list-style-type: none"> • Intake air temperature sensor (defective or disconnected)
H15	Outdoor compressor temperature sensor abnormality	Continue for 5 sec.	—	<ul style="list-style-type: none"> • Compressor temperature sensor (defective or disconnected)
H16	Outdoor Current Transformer open circuit	—	—	<ul style="list-style-type: none"> • Outdoor PCB • IPM (Power transistor) module
H19	Indoor fan motor mechanism lock	7 times occurrence continuously	—	<ul style="list-style-type: none"> • Indoor PCB • Fan motor
H23	Indoor heat exchanger temperature sensor abnormality	Continue for 5 sec.	O (Cooling only)	<ul style="list-style-type: none"> • Heat exchanger temperature sensor (defective or disconnected)
H25	E-Ion breakdown	—	—	<ul style="list-style-type: none"> • Indoor PCB • E-Ion PCB
H27	Outdoor air temperature sensor abnormality	Continue for 5 sec.	O	<ul style="list-style-type: none"> • Outdoor temperature sensor (defective or disconnected)
H28	Outdoor heat exchanger temperature sensor 1 abnormality	Continue for 5 sec.	O	<ul style="list-style-type: none"> • Outdoor heat exchanger temperature sensor (defective or disconnected)
H30	Outdoor discharge temperature sensor abnormality	Continue for 5 sec.	—	<ul style="list-style-type: none"> • Discharge temperature sensor
H32	Outdoor heat exchanger temperature sensor 2 abnormality	—	—	—
H33	Indoor/Outdoor wrong connection	—	—	<ul style="list-style-type: none"> • Indoor/Outdoor supply voltage
H34	Outdoor heat sink temperature sensor abnormality	—	—	—
H36	Outdoor gas pipe temperature sensor abnormality	—	—	—
H37	Outdoor liquid pipe temperature sensor abnormality	—	—	—
H38	Indoor/Outdoor mismatch (brand code)	—	—	—
H39	Abnormal indoor operating unit or standby units	—	—	—
H41	Abnormal wiring or piping connection	—	—	—
H58	Abnormal gas sensor	Continue for 6 hours	—	<ul style="list-style-type: none"> • Gas sensor (defective or disconnected)
H64	Outdoor high pressure sensor abnormality	—	—	—
H97	Outdoor Fan Motor lock abnormality	2 times occurrence within 20 minutes	—	<ul style="list-style-type: none"> • Outdoor PCB • Outdoor Fan Motor
H98	Indoor high pressure protection	—	—	<ul style="list-style-type: none"> • Air filter dirty • Air circulation short circuit
H99	Indoor heat exchanger anti-freezing protection	—	—	<ul style="list-style-type: none"> • Insufficient refrigerant • Air filter dirty
F11	Cooling / Heating cycle changeover abnormality	4 times occurrence within 30 minutes	—	<ul style="list-style-type: none"> • 4-way valve • V-coil
F17	Indoor standby units freezing abnormality	—	—	—
F90	PFC control	4 times occurrence within 10 minutes	—	<ul style="list-style-type: none"> • Voltage at PFC

Diagnosis display	Abnormality / Protection control	Abnormality Judgement	Emergency operation	Primary location to verify
F91	Refrigeration cycle abnormality	7 times occurrence continuously	—	• No refrigerant (3-way valve is closed)
F93	Outdoor compressor abnormal revolution	4 times occurrence within 20 minutes	—	• Outdoor compressor
F94	Compressor discharge pressure overshoot protection	—	—	—
F95	Outdoor cooling high pressure protection	4 times occurrence within 20 minutes	—	• Outdoor refrigerant circuit
F96	IPM (power transistor) overheating protection	4 times occurrence within 30 minutes	—	• Excess refrigerant • Improper heat radiation • IPM (Power transistor)
F97	Outdoor compressor overheating protection	4 times occurrence within 20 minutes	—	• Insufficient refrigerant • Compressor
F98	Total running current protection	3 times occurrence within 20 minutes	—	• Excess refrigerant • Improper heat radiation
F99	Outdoor Direct Current (DC) peak detection	7 times occurrence continuously	—	• Outdoor PCB • IPM (Power transistor) • Compressor

Note:

“O” - Frequency measured and fan speed fixed.

The memory data of error code is erased when the power supply is cut off, or press the Auto Switch until “beep” sound heard following by pressing the “CHECK” button at Remote Control.

Although operation forced to stop when abnormality detected, emergency operation is possible for certain errors (refer to Error Codes Table) by using Remote Control or Auto Switch at indoor unit. However, the Remote Control signal receiving sound is changed from one “beep” to four “beep” sounds.

15.4. Self-diagnosis Method

15.4.1. H11 (Indoor/Outdoor Abnormal Communication)

Malfunction Decision Conditions

During startup and operation of cooling and heating, the data received from outdoor unit in indoor unit signal transmission is checked whether it is normal.

Malfunction Caused

- Faulty indoor unit PCB.
- Faulty outdoor unit PCB.
- Indoor unit-outdoor unit signal transmission error due to wrong wiring.
- Indoor unit-outdoor unit signal transmission error due to breaking of wire in the connection wires between the indoor and outdoor units.
- Indoor unit-outdoor unit signal transmission error due to disturbed power supply waveform.

Troubleshooting

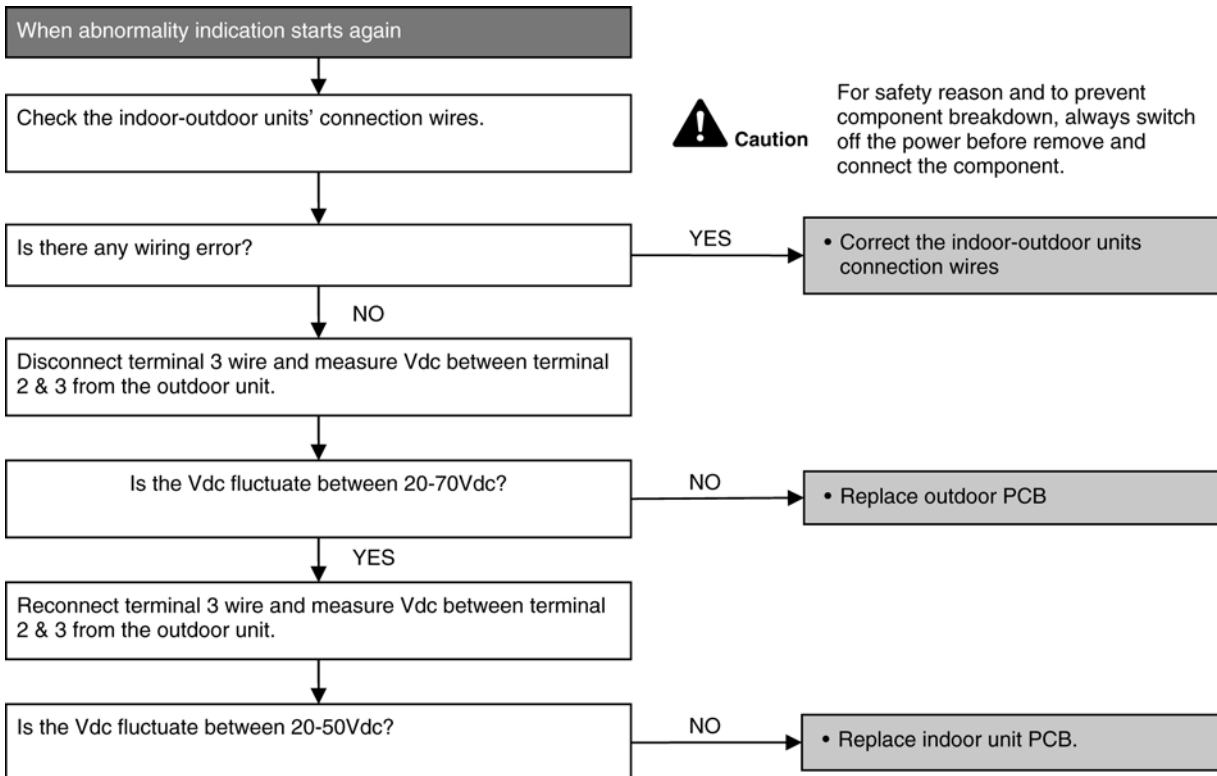

15.4.2. H12 (Indoor/Outdoor Capacity Rank Mismatched)

Malfunction Decision Conditions

During startup, error code appears when different types of indoor and outdoor units are interconnected.

Malfunction Caused

- Wrong models interconnected.
- Wrong indoor unit or outdoor unit PCBs mounted.
- Indoor unit or outdoor unit PCBs defective.
- Indoor-outdoor unit signal transmission error due to wrong wiring.
- Indoor-outdoor unit signal transmission error due to breaking of wire 3 in the connection wires between the indoor and outdoor units.

Troubleshooting

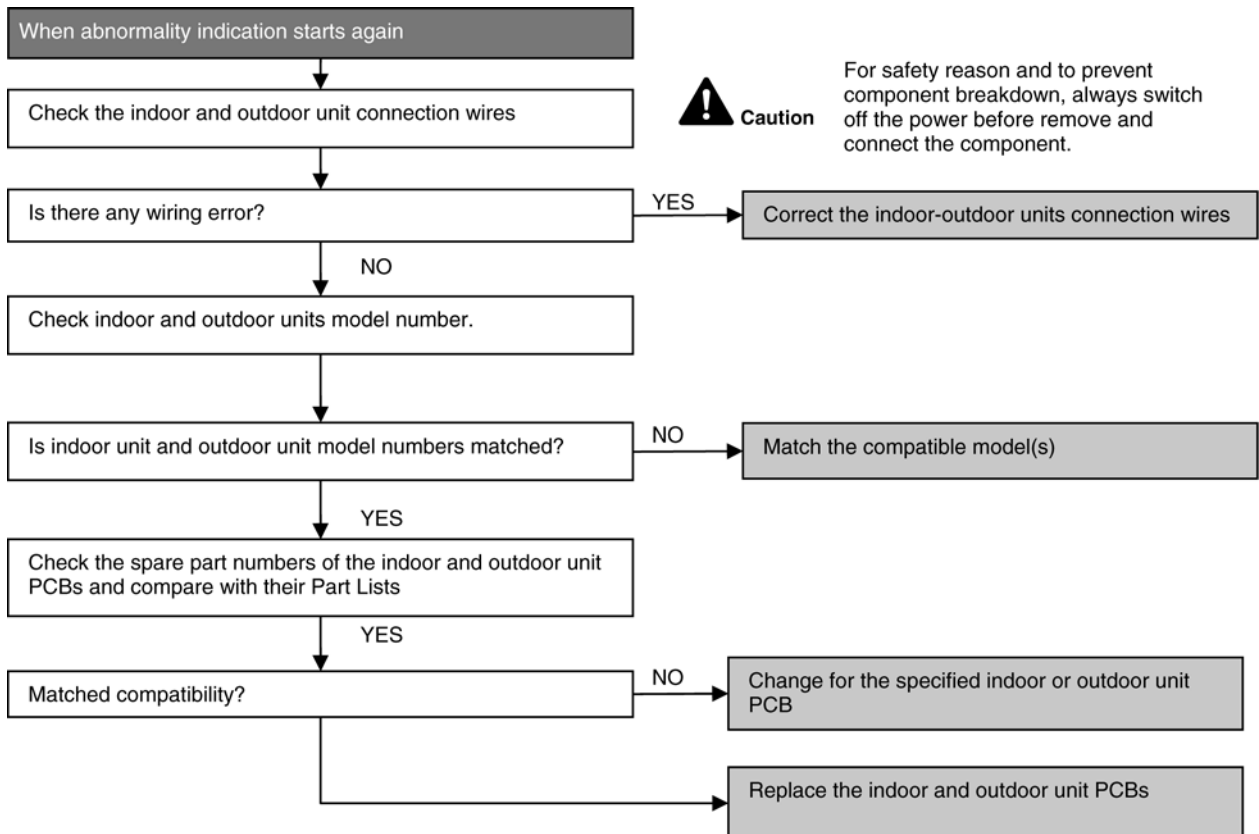

15.4.3. H14 (Indoor Intake Air Temperature Sensor Abnormality)

Malfunction Decision Conditions

During startup and operation of cooling and heating, the temperatures detected by the indoor intake air temperature sensor are used to determine sensor errors.

Malfunction Caused

- Faulty connector connection.
- Faulty sensor.
- Faulty PCB.

Troubleshooting

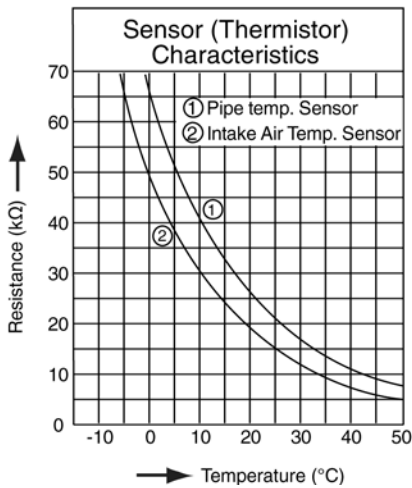
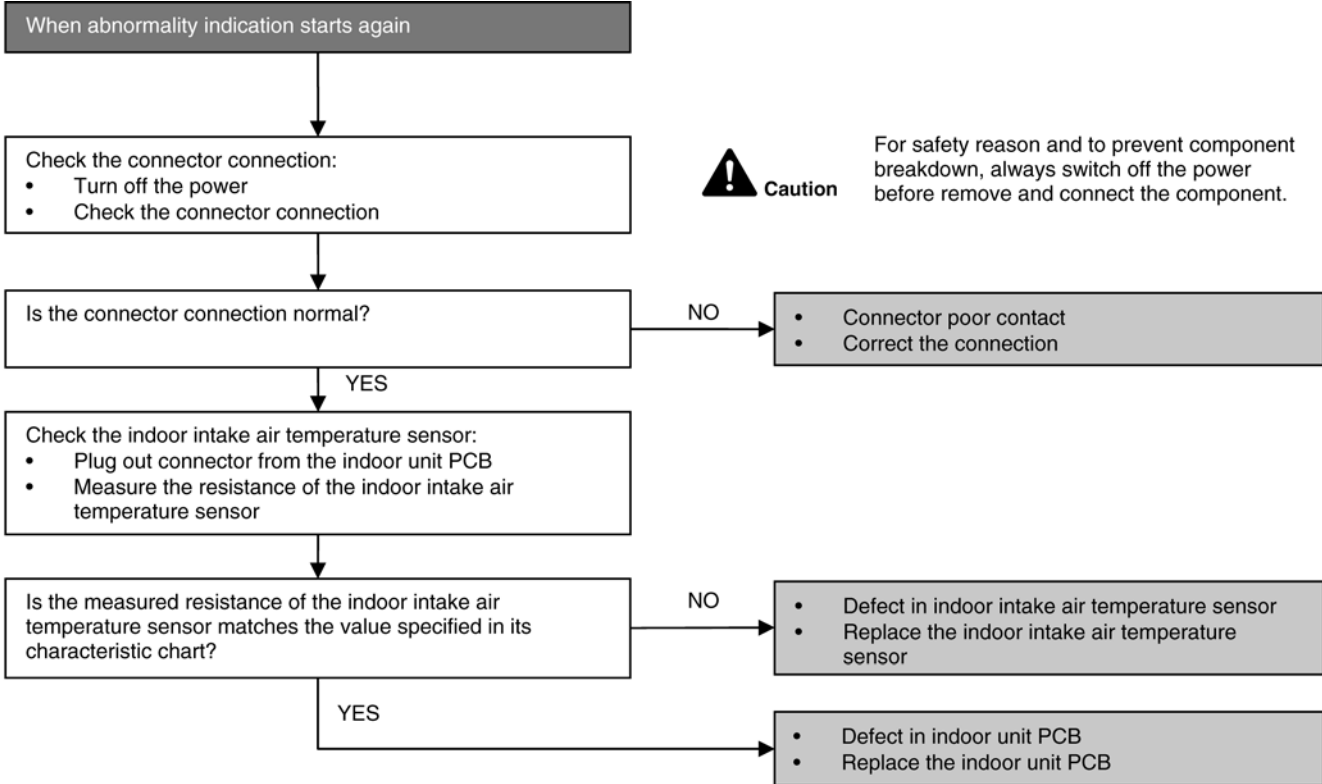

15.4.4. H15 (Compressor Temperature Sensor Abnormality)

Malfunction Decision Conditions

During startup and operation of cooling and heating, the temperatures detected by the outdoor compressor temperature sensor are used to determine sensor errors.

Malfunction Caused

- Faulty connector connection.
- Faulty sensor.
- Faulty PCB.

Troubleshooting

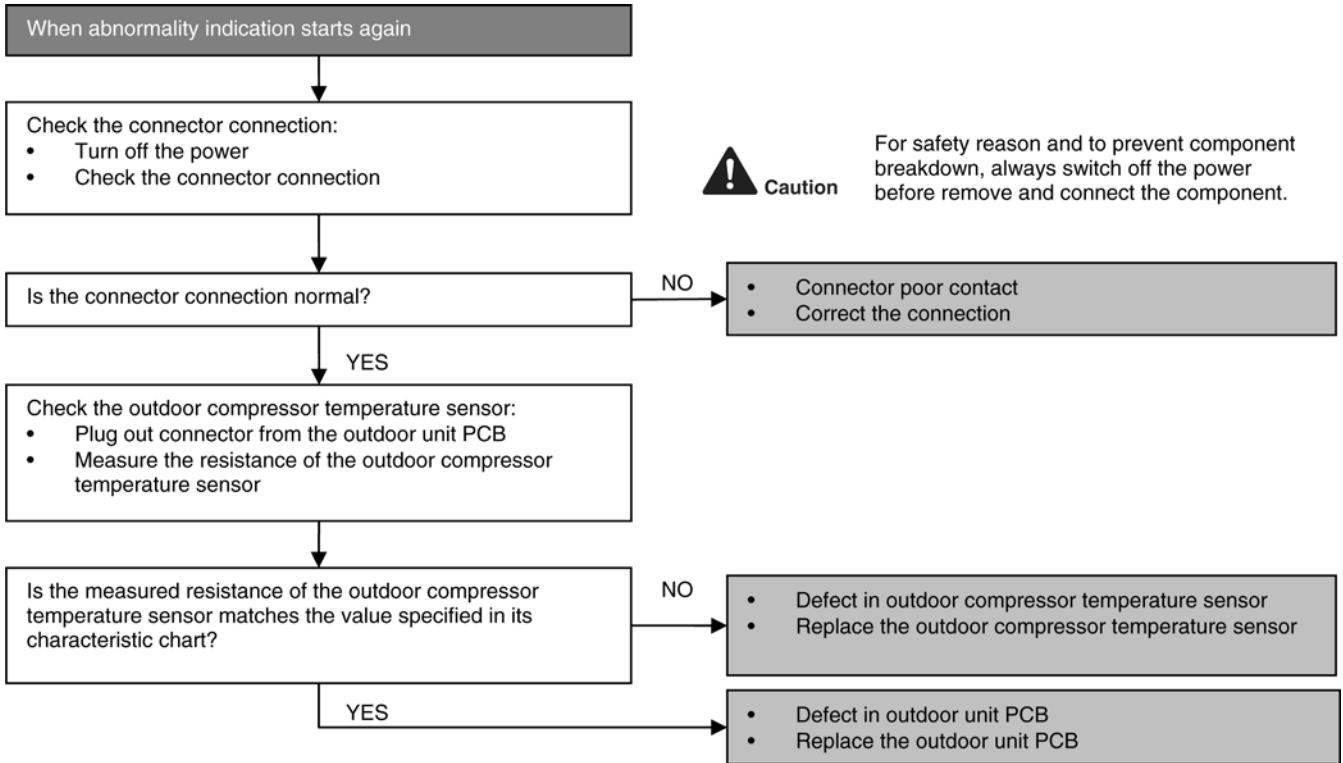

Caution For safety reason and to prevent component breakdown, always switch off the power before remove and connect the component.

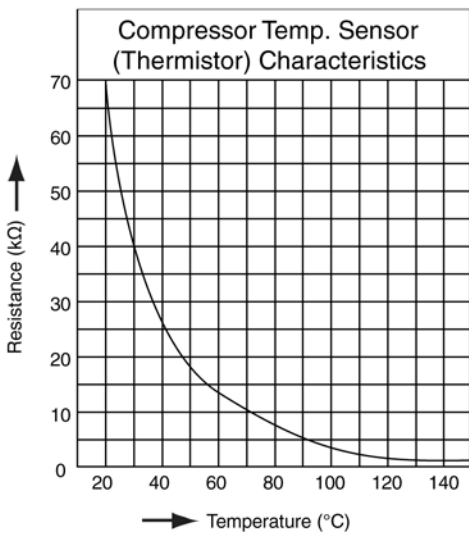

15.4.5. H16 (Outdoor Current Transformer Open Circuit)

Malfunction Decision Conditions

A current transformer (CT) is detected by checking the compressor running frequency (\geq rated frequency) and CT detected input current (less than 0.65A) for continuously 20 seconds.

Malfunction Caused

- CT defective
- Outdoor PCB defective
- Compressor defective (low compression)

Troubleshooting

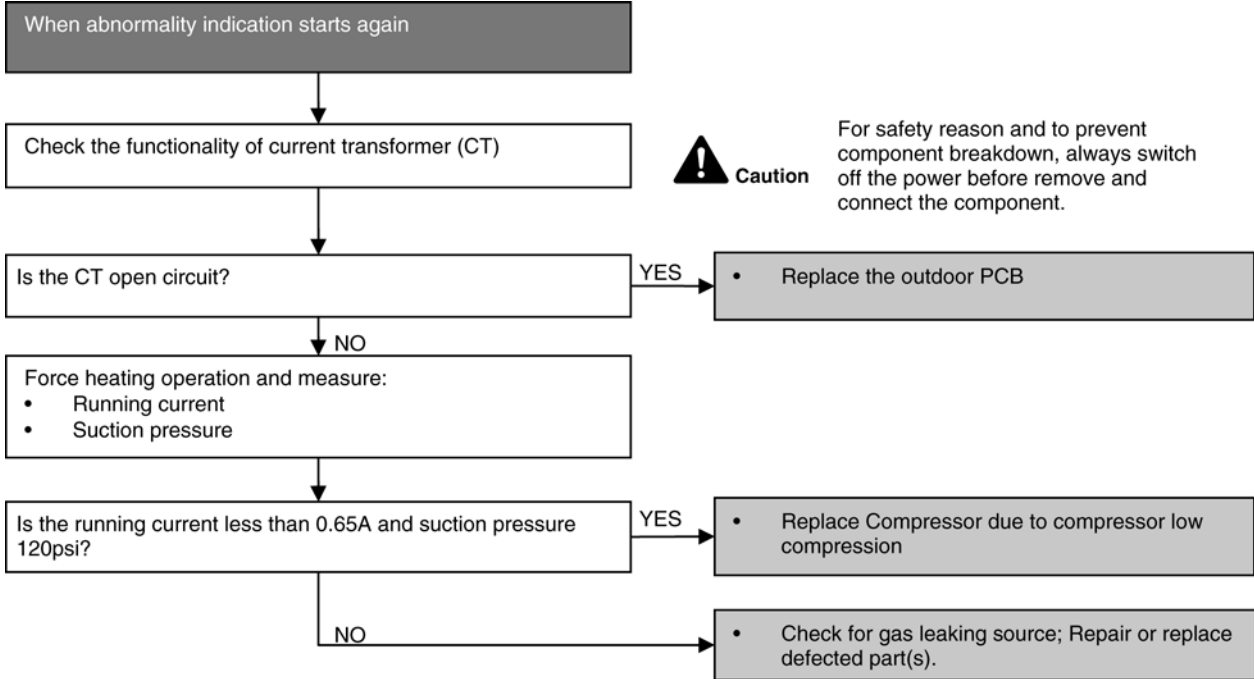

15.4.6. H19 (Indoor Fan Motor - DC Motor Mechanism Locked)

Malfunction Decision Conditions

The rotation speed detected by the Hall IC during fan motor operation is used to determine abnormal fan motor (feedback of rotation > 2550rpm or < 50rpm)

Malfunction Caused

- Operation stops due to short circuit inside the fan motor winding.
- Operation stops due to breaking of wire inside the fan motor.
- Operation stops due to breaking of fan motor lead wires.
- Operation stops due to Hall IC malfunction.
- Operation error due to faulty indoor unit PCB.

Troubleshooting

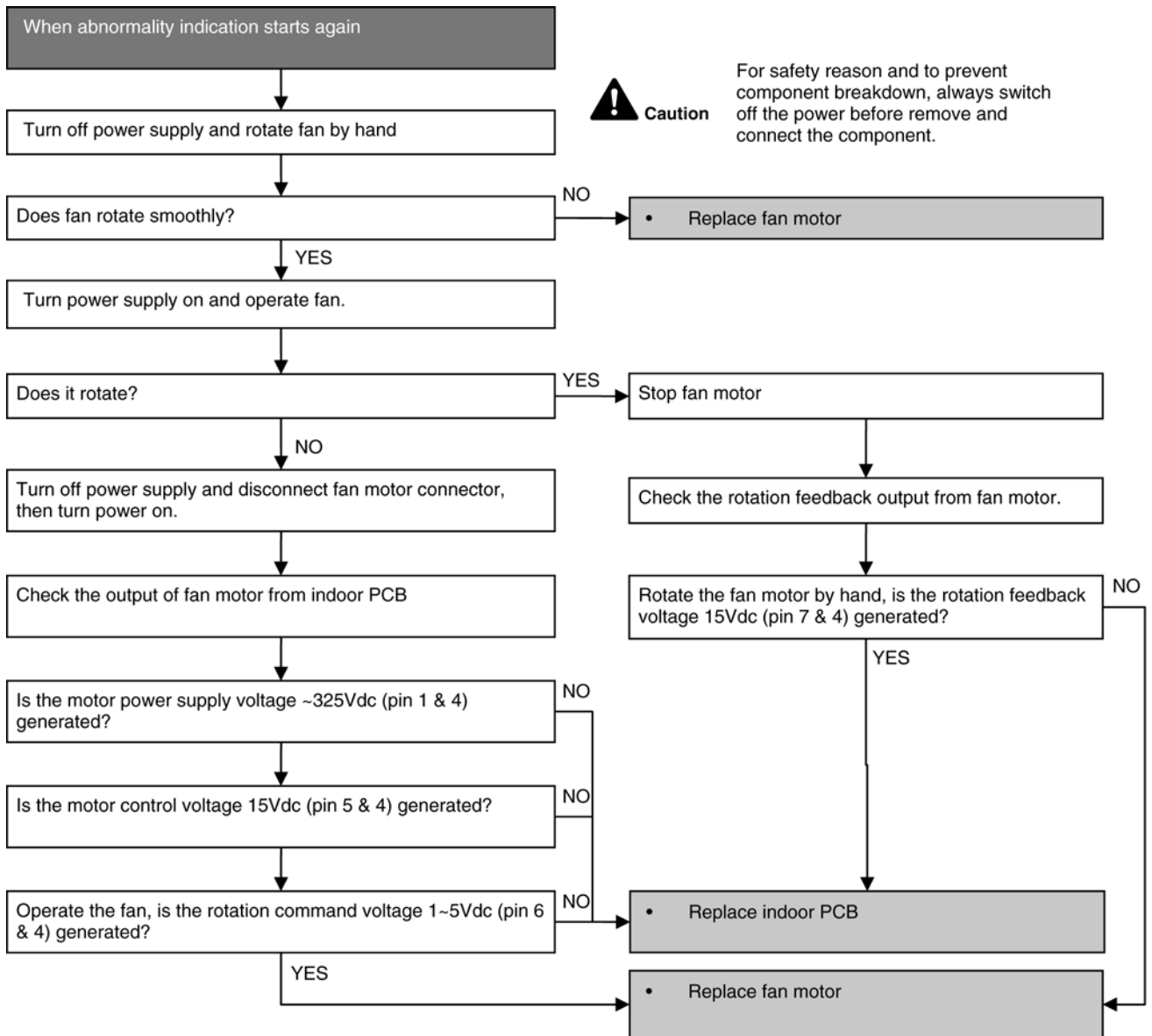

15.4.7. H23 (Indoor Pipe Temperature Sensor Abnormality)

Malfunction Decision Conditions

During startup and operation of cooling and heating, the temperatures detected by the indoor heat exchanger temperature sensor are used to determine sensor errors.

Malfunction Caused

- Faulty connector connection.
- Faulty sensor.
- Faulty PCB.

Troubleshooting

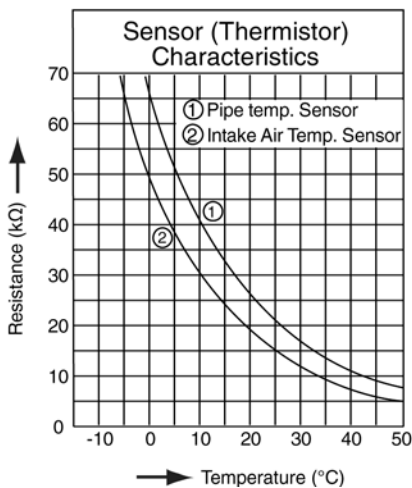
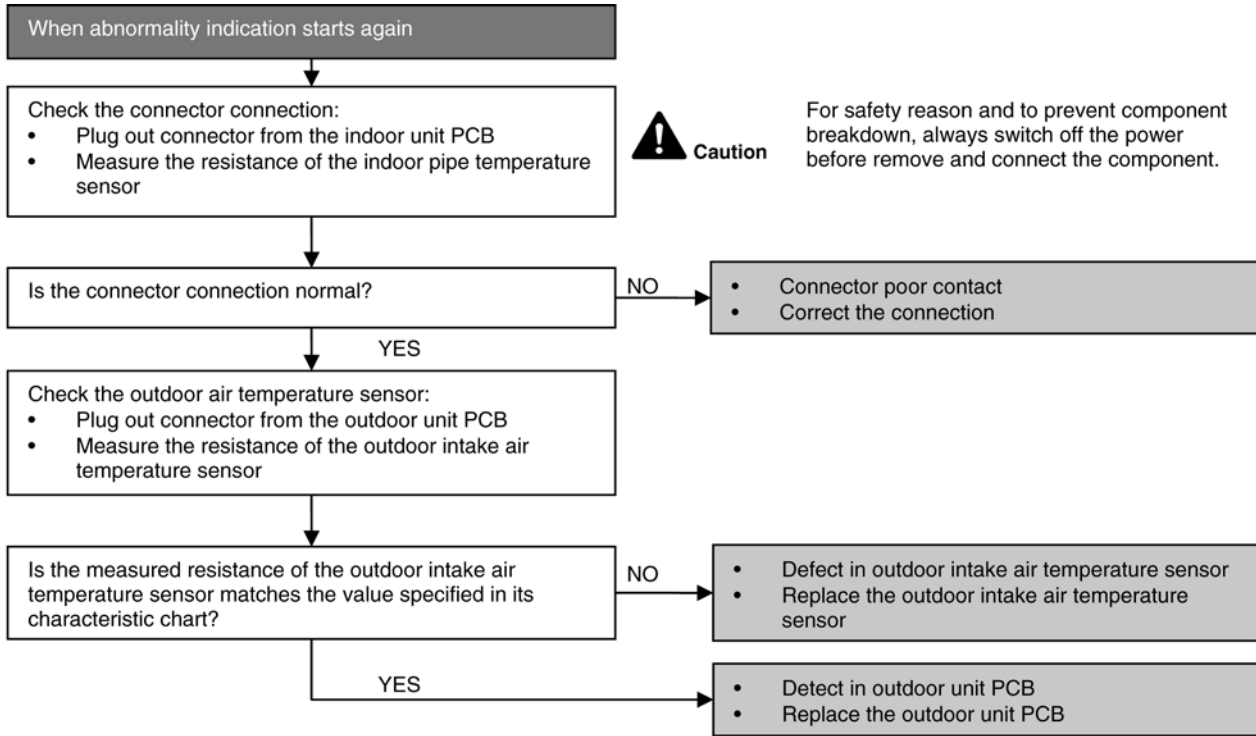

15.4.8. H25 (e-ion Air Purifying System Abnormal)

Malfunction Decision Conditions

During standby of cooling and heating operation, e-ion breakdown occurs and air conditioner stops operation.

Malfunction Caused

- Faulty indoor main PCB.
- Faulty indoor e-ion power module.

Troubleshooting

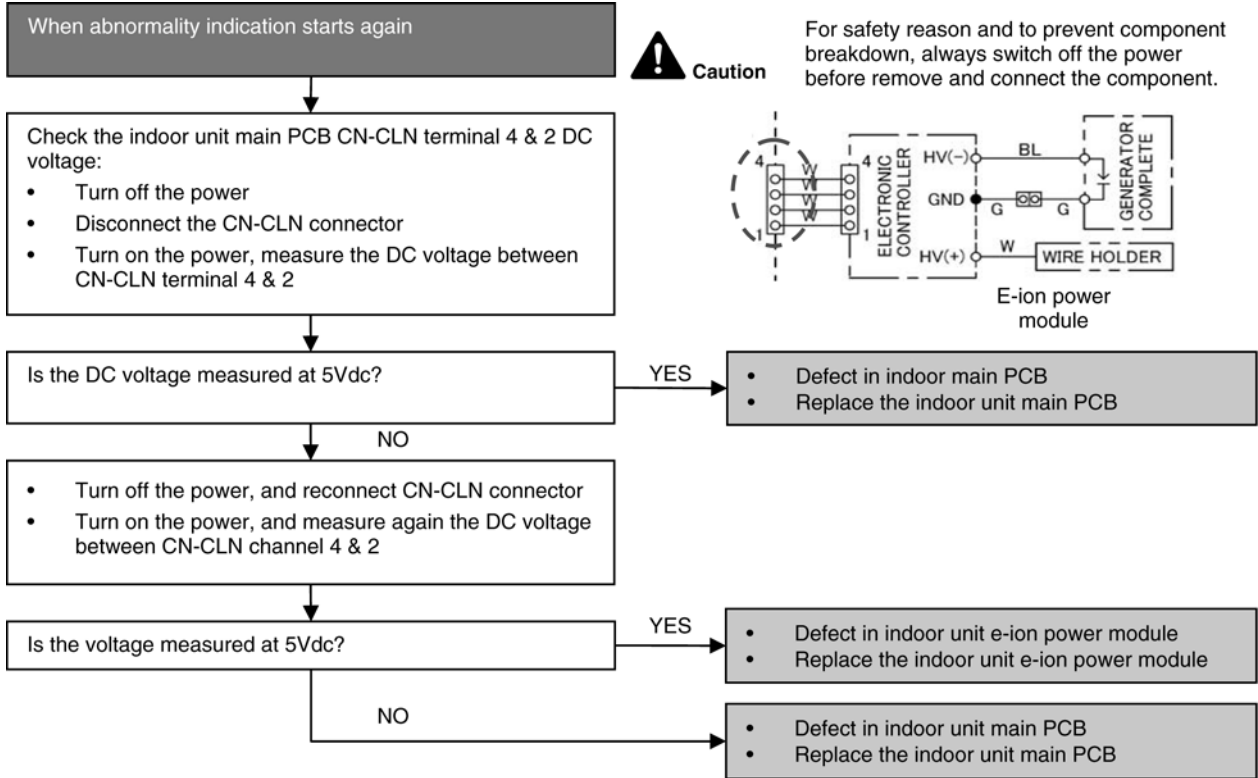

15.4.9. H27 (Outdoor Air Temperature Sensor Abnormality)

Malfunction Decision Conditions

During startup and operation of cooling and heating, the temperatures detected by the outdoor air temperature sensor are used to determine sensor errors.

Malfunction Caused

- Faulty connector connection.
- Faulty sensor.
- Faulty PCB.

Troubleshooting

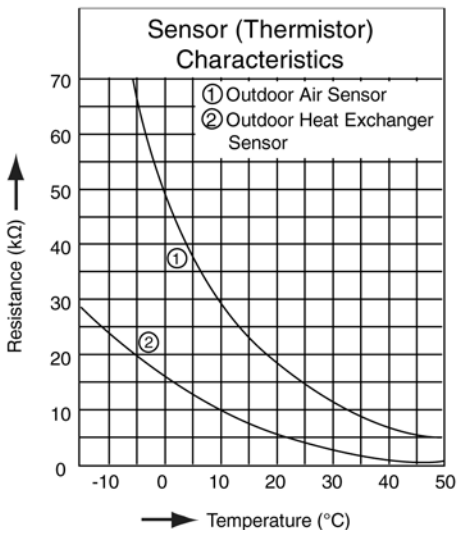
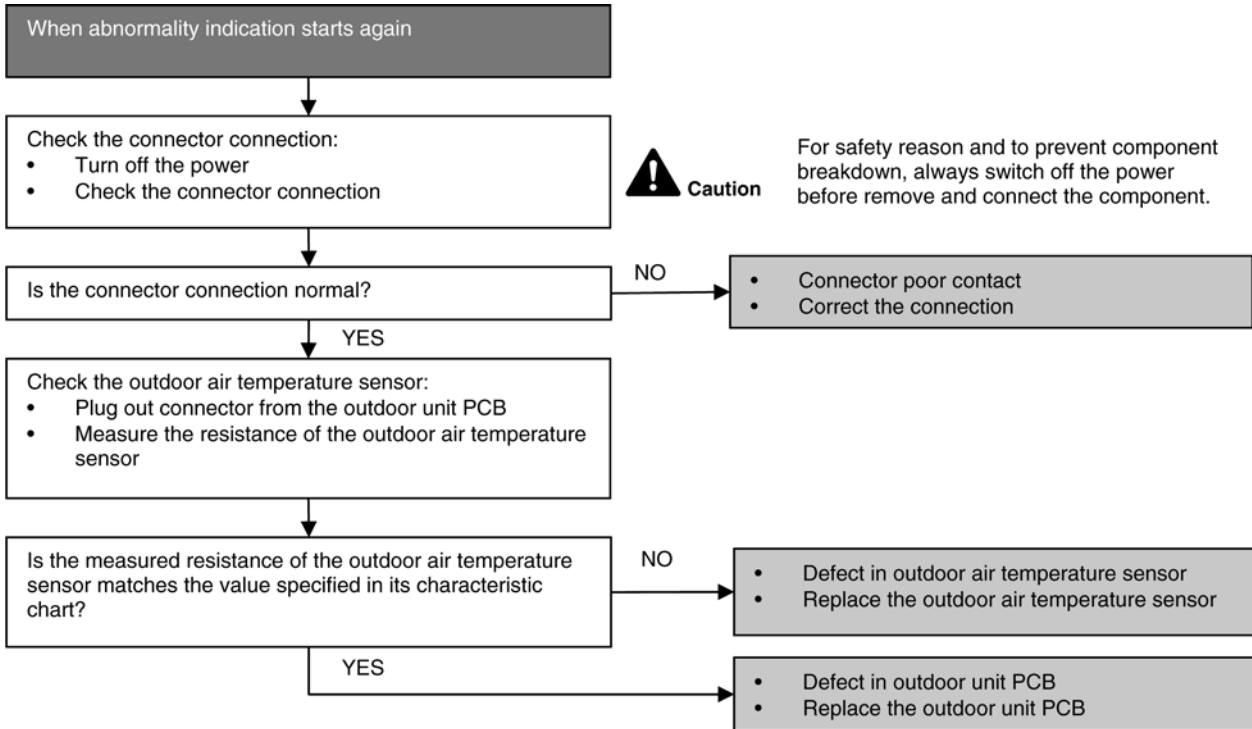

15.4.10. H28 (Outdoor Pipe Temperature Sensor Abnormality)

Malfunction Decision Conditions

During startup and operation of cooling and heating, the temperatures detected by the outdoor pipe temperature sensor are used to determine sensor errors.

Malfunction Caused

- Faulty connector connection.
- Faulty sensor.
- Faulty PCB.

Troubleshooting

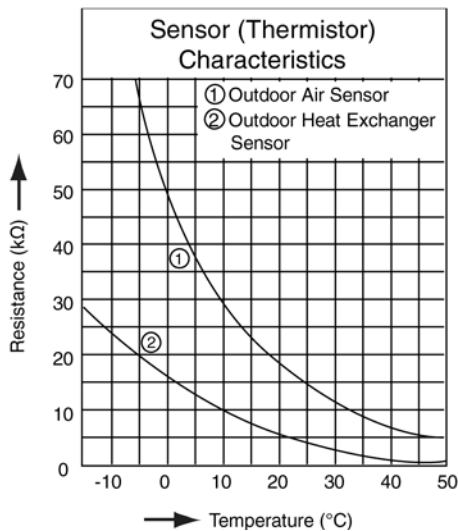
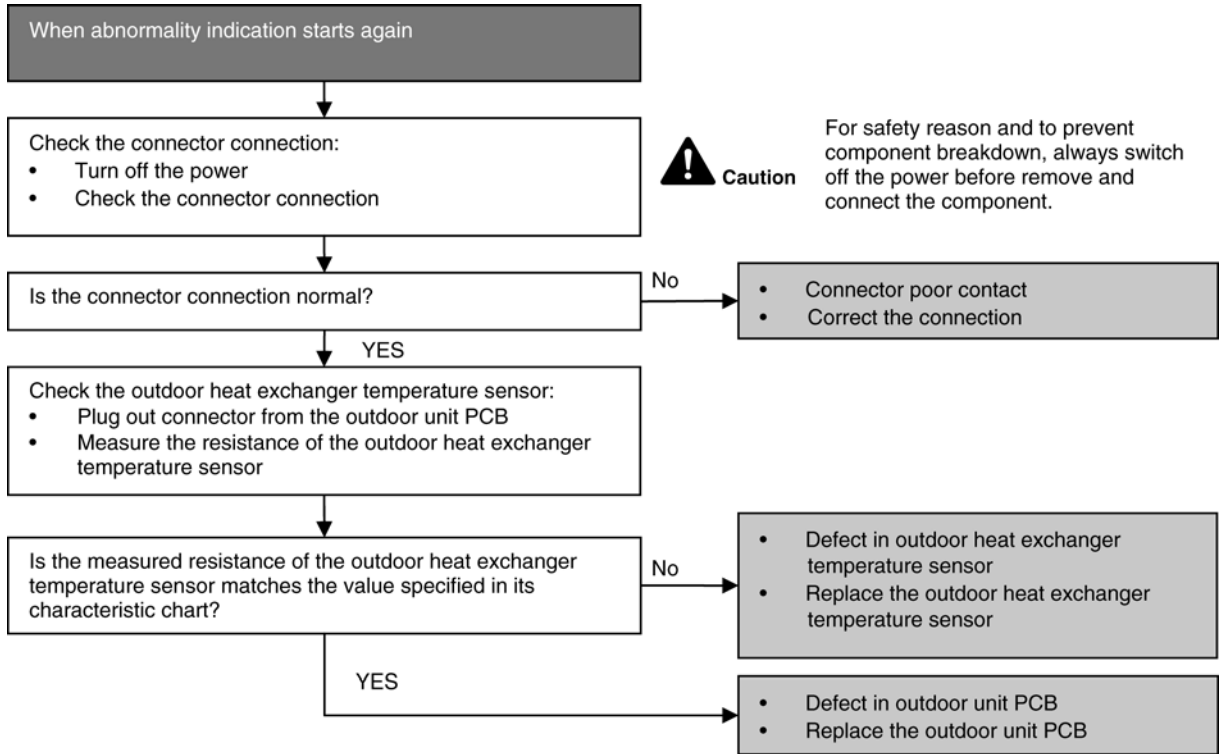

15.4.11. H30 (Compressor Discharge Temperature Sensor Abnormality)

Malfunction Decision Conditions

During startup and operation of cooling and heating, the temperatures detected by the outdoor discharge pipe temperature sensor are used to determine sensor errors.

Malfunction Caused

- Faulty connector connection.
- Faulty sensor.
- Faulty PCB.

Troubleshooting

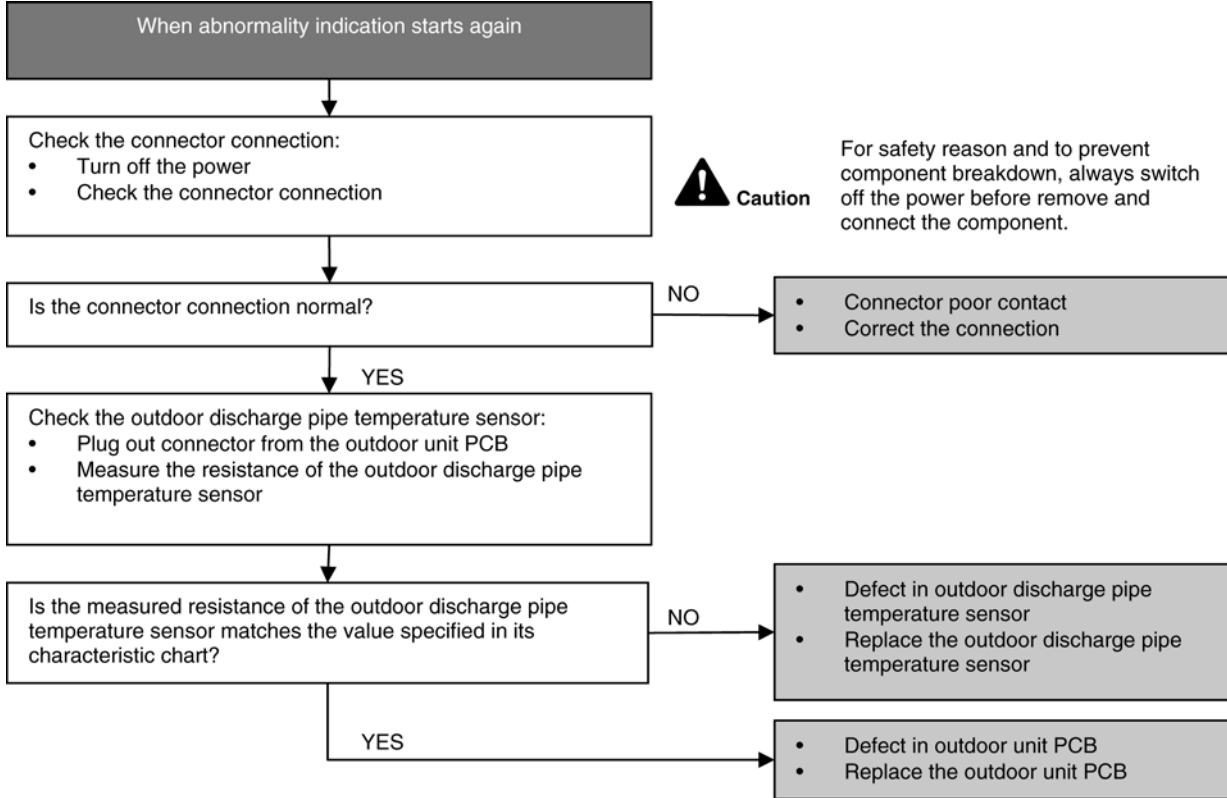

15.4.12. H32 (Outdoor Heat Exchanger Temperature Sensor 2 Abnormality)

Malfunction Decision Conditions

During startup and operation of cooling and heating, the temperatures detected by the outdoor heat exchanger temperature sensor are used to determine sensor errors.

Malfunction Caused

- Faulty connector connection.
- Faulty sensor.
- Faulty PCB.

Troubleshooting

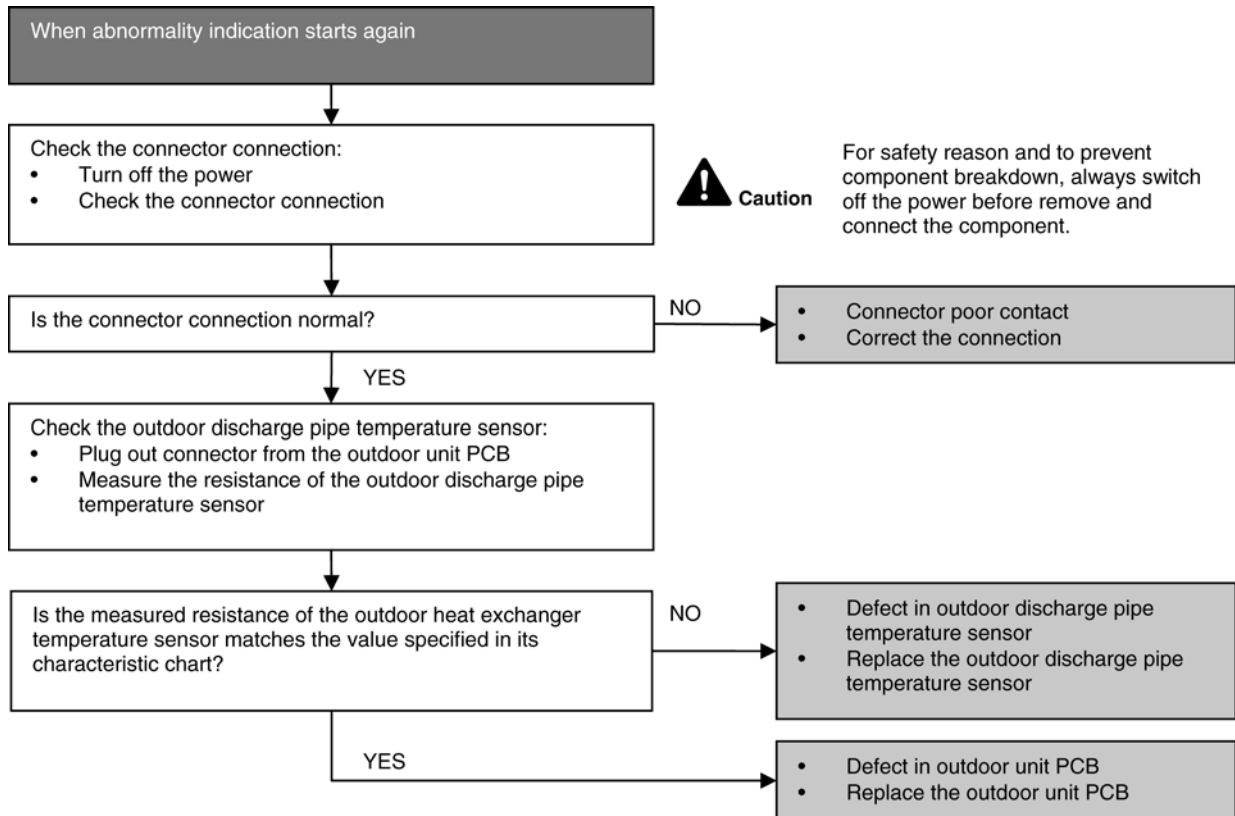

15.4.13. H33 (Unspecified Voltage between Indoor and Outdoor)

Malfunction Decision Conditions

The supply power is detected for its requirement by the indoor/outdoor transmission.

Malfunction Caused

- Wrong models interconnected.
- Wrong indoor unit and outdoor unit PCBs used.
- Indoor unit or outdoor unit PCB defective.

Troubleshooting

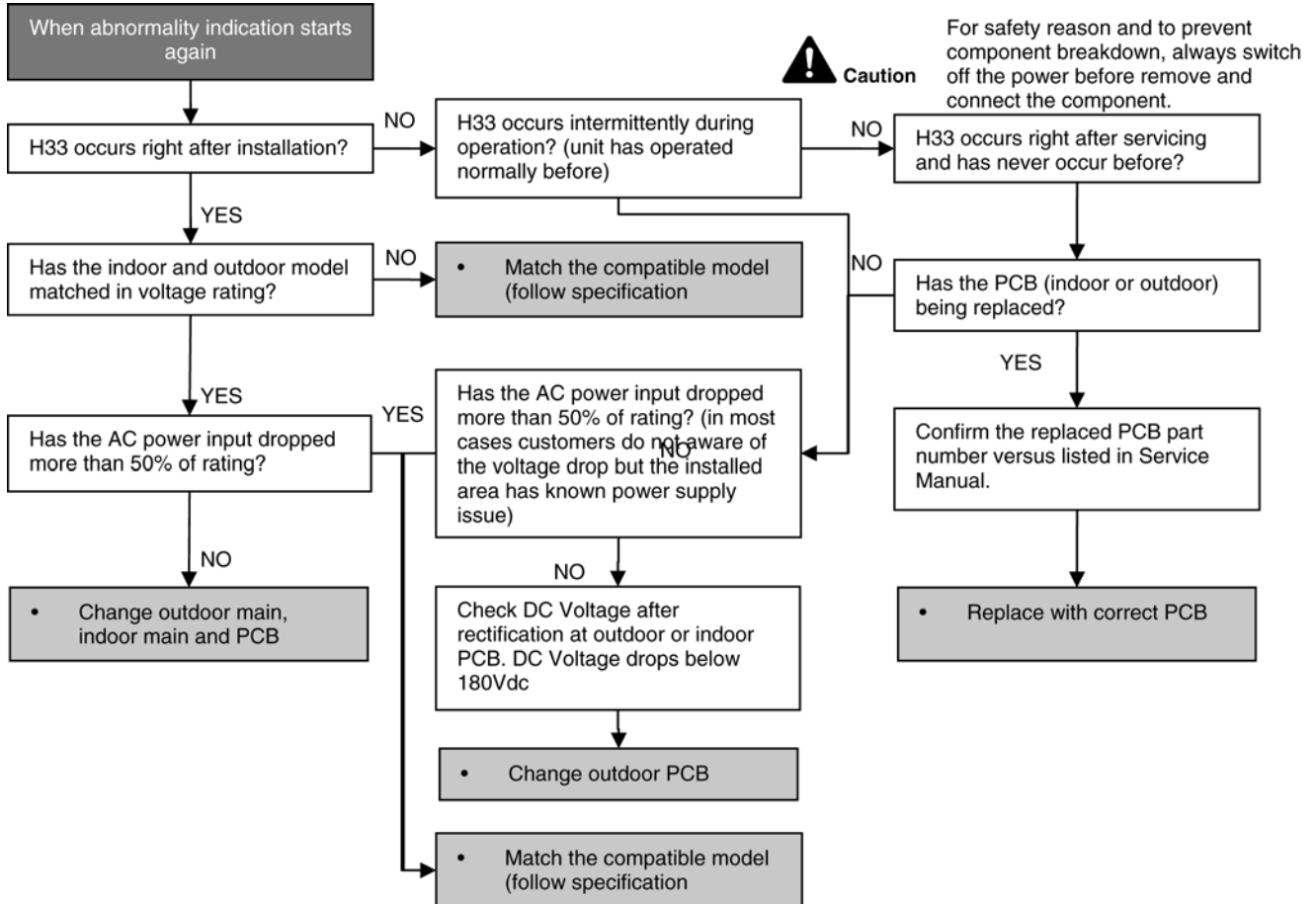

15.4.14. H34 (Outdoor Heat Sink Temperature Sensor Abnormality)

Malfunction Decision Conditions

During startup and operation of cooling and heating, the temperatures detected by the outdoor heat sink temperature sensor are used to determine sensor errors.

Malfunction Caused

- Faulty connector connection.
- Faulty sensor.
- Faulty PCB.

Troubleshooting

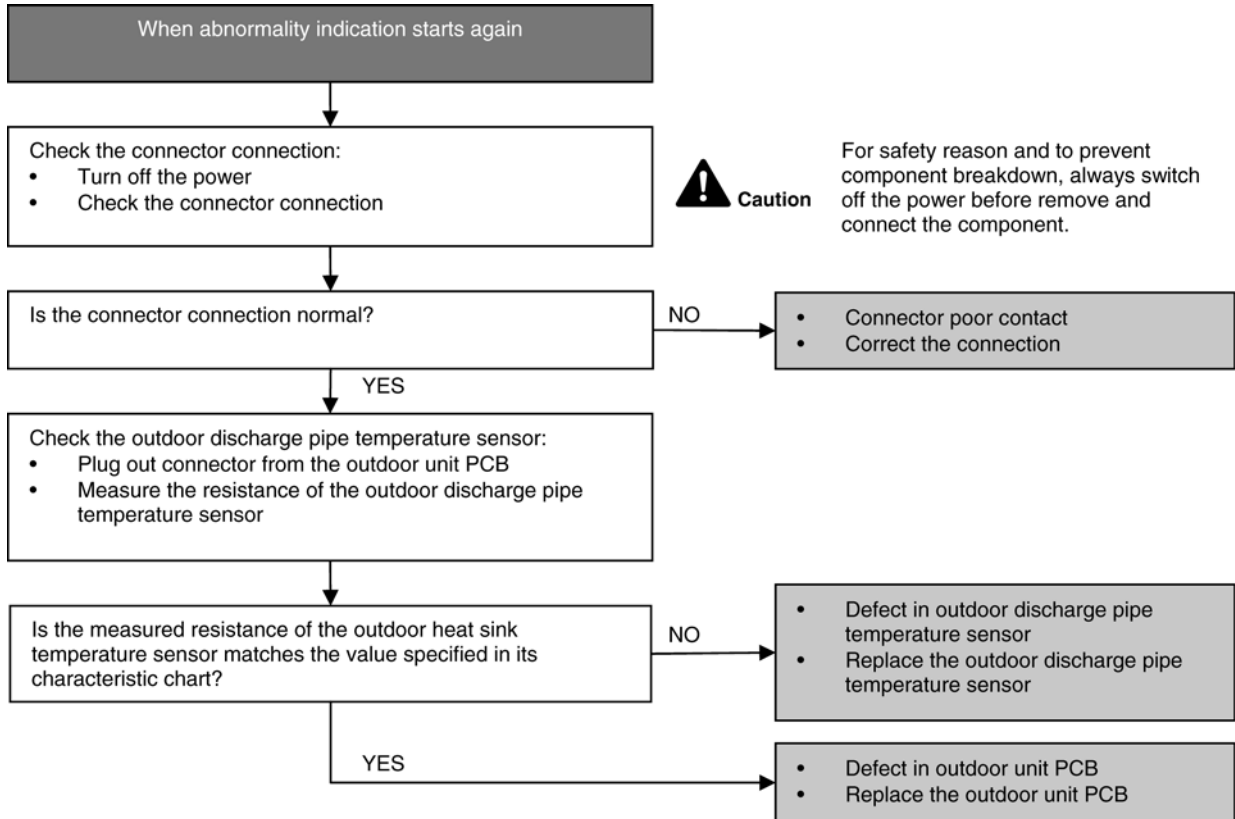

15.4.15. H36 (Outdoor Gas Pipe Sensor Abnormality)

Malfunction Decision Conditions

During startup and operation of cooling and heating, the temperatures detected by the outdoor gas pipe temperature sensor are used to determine sensor errors.

Malfunction Caused

- Faulty connector connection.
- Faulty sensor.
- Faulty PCB.

Troubleshooting

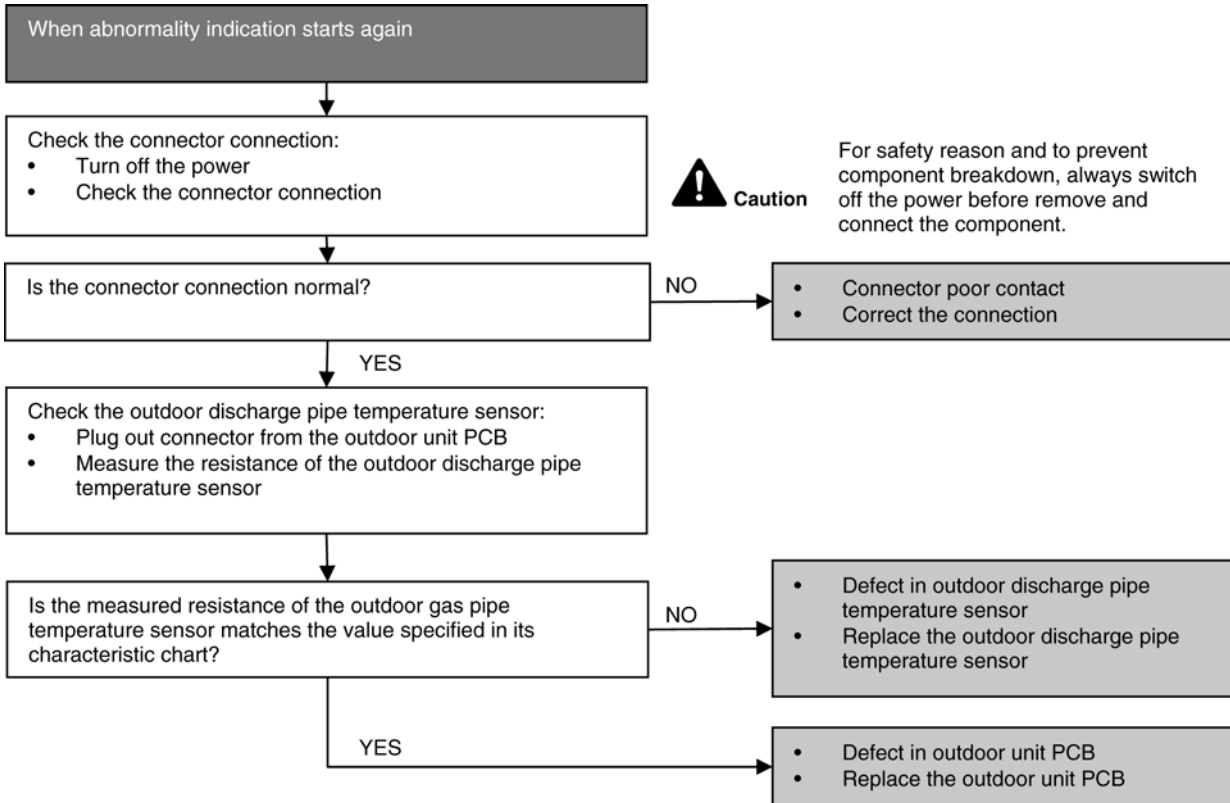

15.4.16. H37 (Outdoor Liquid Pipe Temperature Sensor Abnormality)

Malfunction Decision Conditions

During startup and operation of cooling and heating, the temperatures detected by the outdoor liquid pipe temperature sensor are used to determine sensor errors.

Malfunction Caused

- Faulty connector connection.
- Faulty sensor.
- Faulty PCB.

Troubleshooting

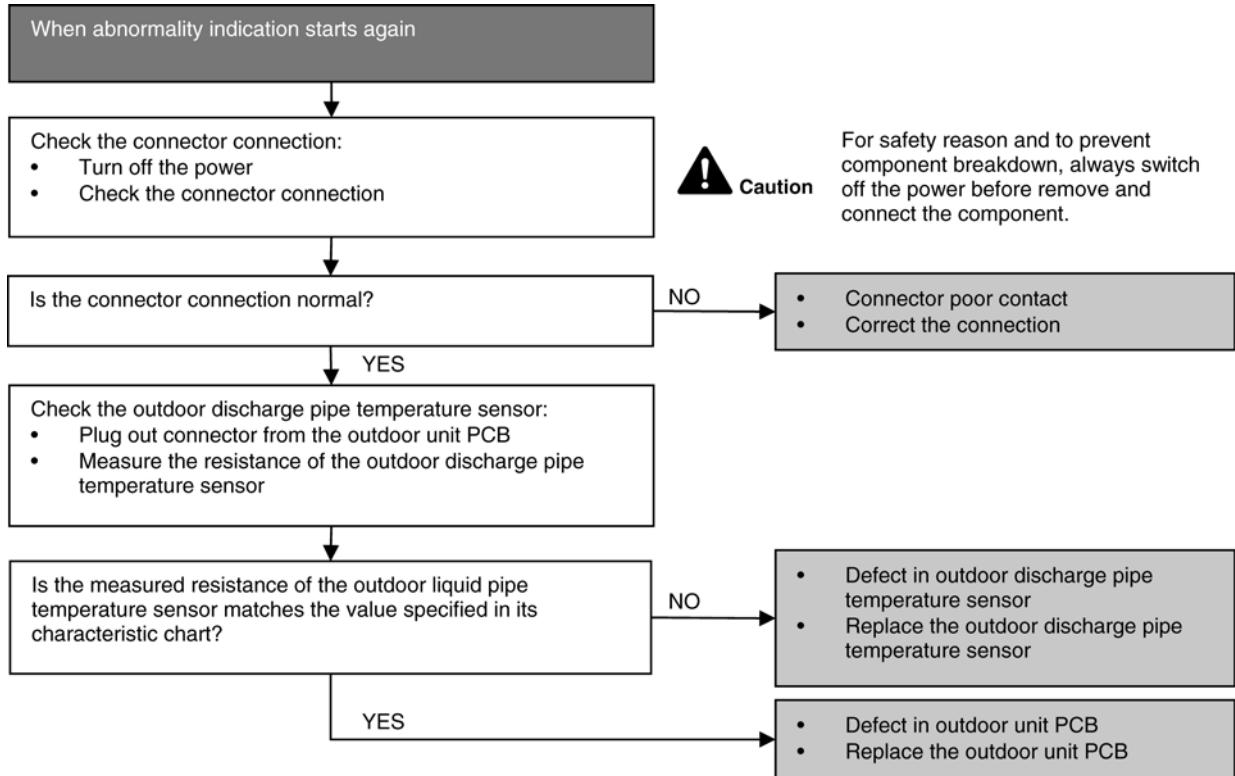

15.4.17. H58 (Patrol Sensor Abnormality)

Malfunction Decision Conditions

- If Patrol sensor feedback is 0V or 5V continuous for 6 hours.
- Error will display only when the Patrol operation is ON.

Malfunction Caused

- Faulty connector connection.
- Faulty Patrol sensor.

Troubleshooting

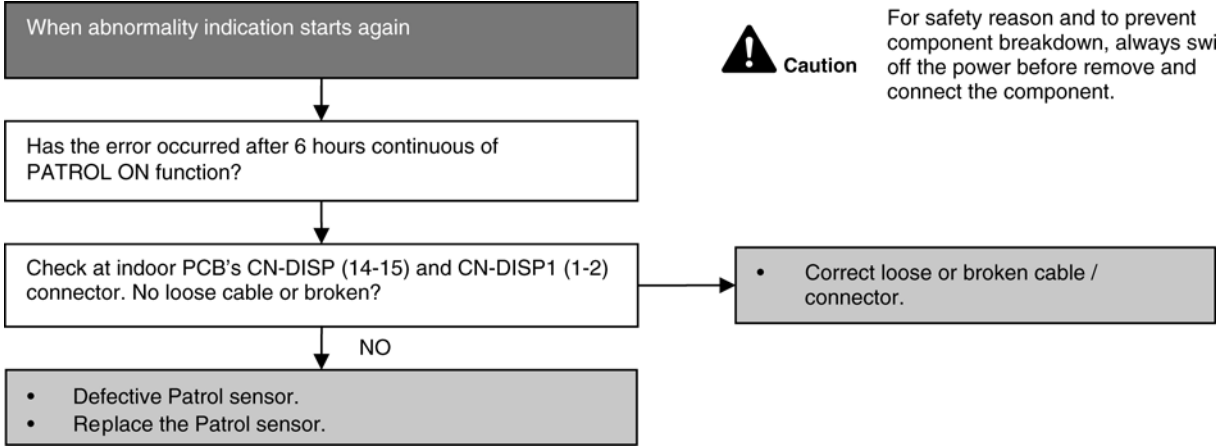

Caution

For safety reason and to prevent component breakdown, always switch off the power before remove and connect the component.

15.4.18. H97 (Outdoor Fan Motor - DC Motor Mechanism Locked)

Malfunction Decision Conditions

The rotation speed detected by the Hall IC during fan motor operation is used to determine abnormal fan motor.

Malfunction Caused

- Operation stops due to short circuit inside the fan motor winding.
- Operation stops due to breaking of wire inside the fan motor.
- Operation stops due to breaking of fan motor lead wires.
- Operation stops due to Hall IC malfunction.
- Operation error due to faulty outdoor unit PCB.

Troubleshooting

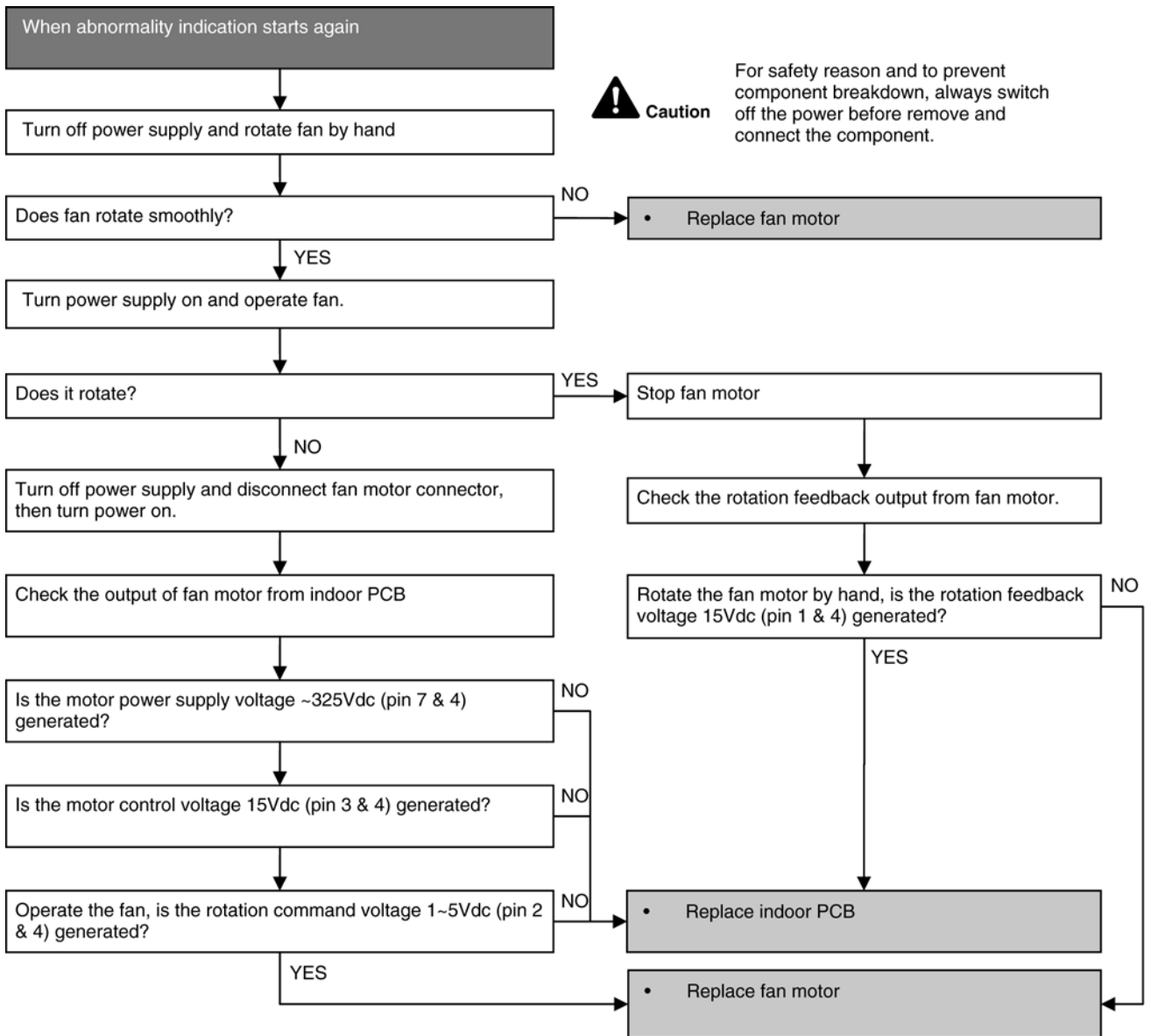

15.4.19. H98 (Indoor High Pressure Protection)

Error Code will not display (no Timer LED blinking) but store in EEPROM

Malfunction Decision Conditions

During heating operation, the temperature detected by the indoor pipe temperature sensor is above 60°C.

Malfunction Caused

- Clogged air filter of the indoor unit
- Dust accumulation on the indoor unit heat exchanger
- Air short circuit
- Detection error due to faulty indoor pipe temperature sensor
- Detection error due to faulty indoor unit PCB

Troubleshooting

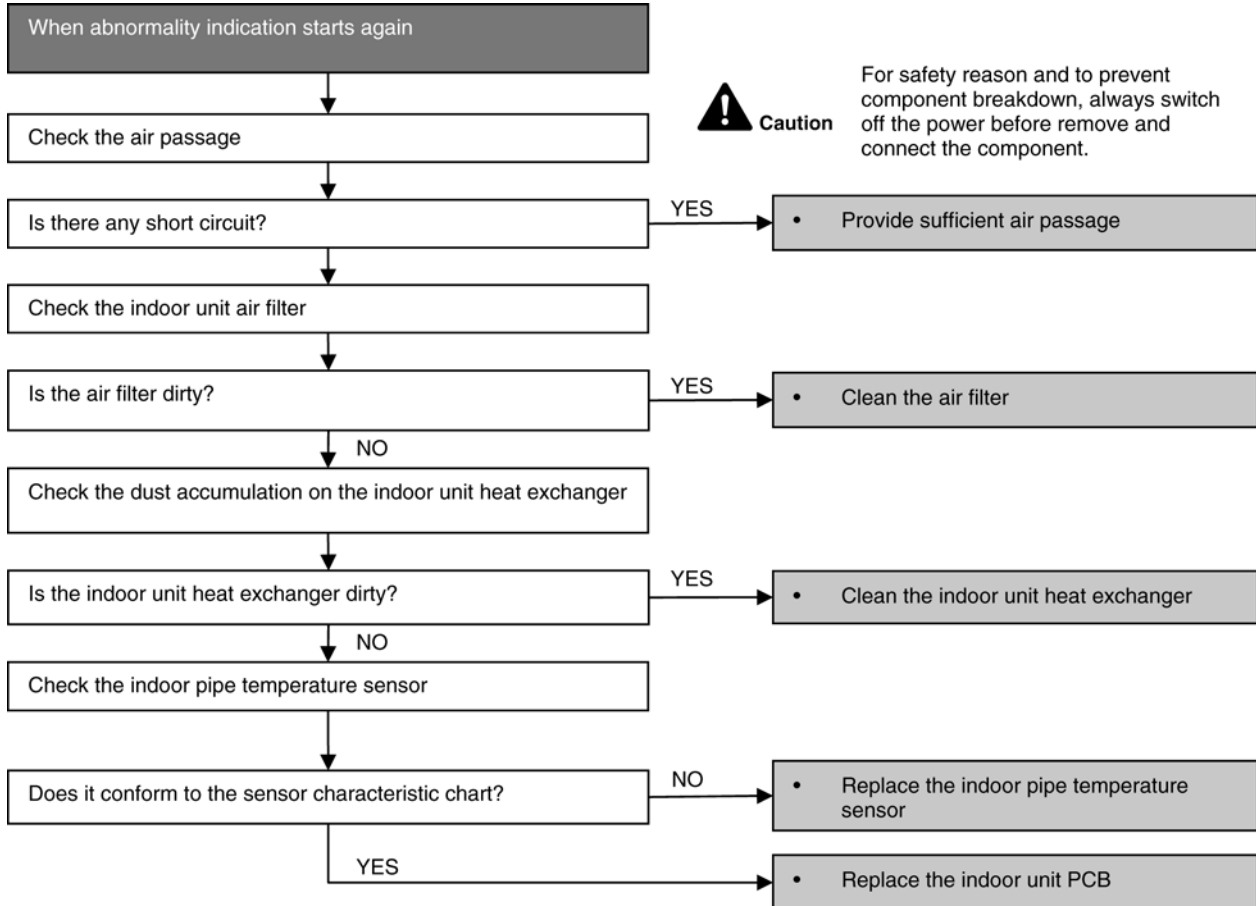

15.4.20. H99 (Indoor Freeze Prevention Protection: Cooling or Soft Dry)

Error code will not display (no TIMER LED blinking) but store in EEPROM

Malfunction Decision Conditions

Freeze prevention control takes place (when indoor pipe temperature is lower than 2°C)

Malfunction Caused

- Clogged air filter of the indoor unit
- Dust accumulation on the indoor unit heat exchanger
- Air short circuit
- Detection error due to faulty indoor pipe temperature sensor
- Detection error due to faulty indoor unit PCB

Troubleshooting

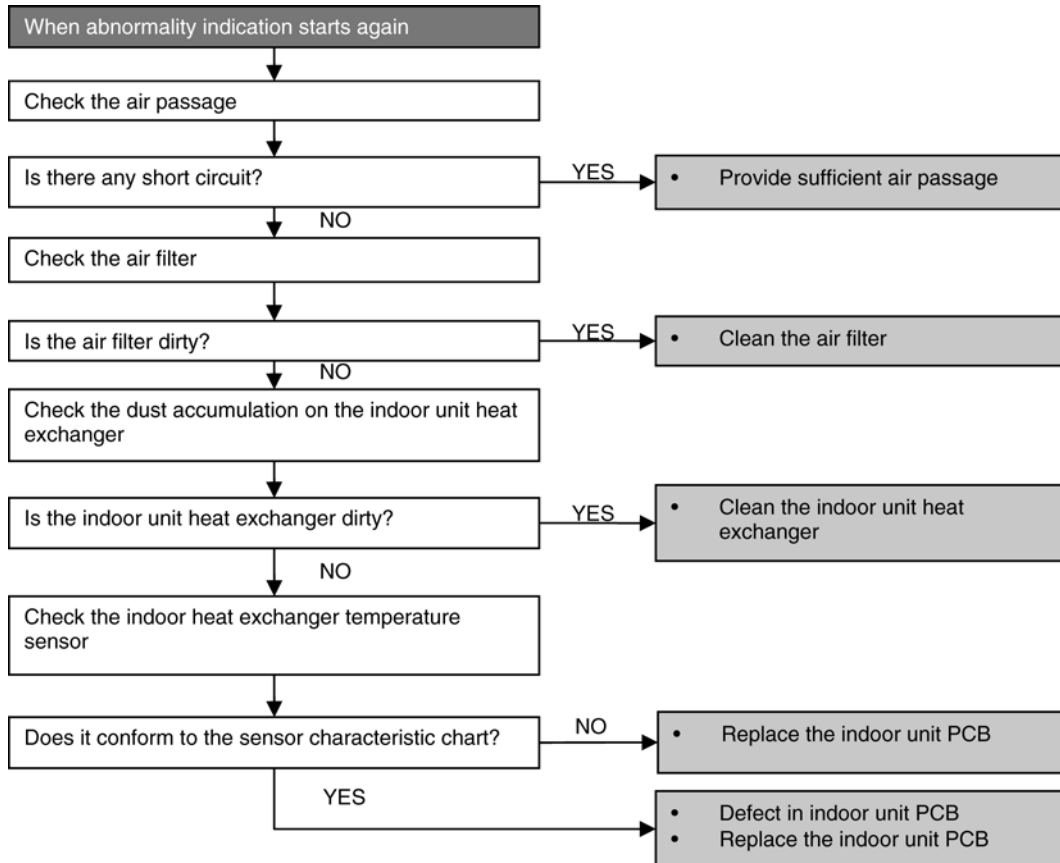

15.4.21. F11 (4-way valve Abnormality)

Malfunction Decision Conditions

- When heating operation, when indoor pipe temperature is below 10°C
- When cooling operation, when indoor pipe temperature is above 45°C

Malfunction Caused

- Connector in poor contact
- Faulty sensor
- Faulty outdoor unit PCB
- 4-way valve defective

Troubleshooting

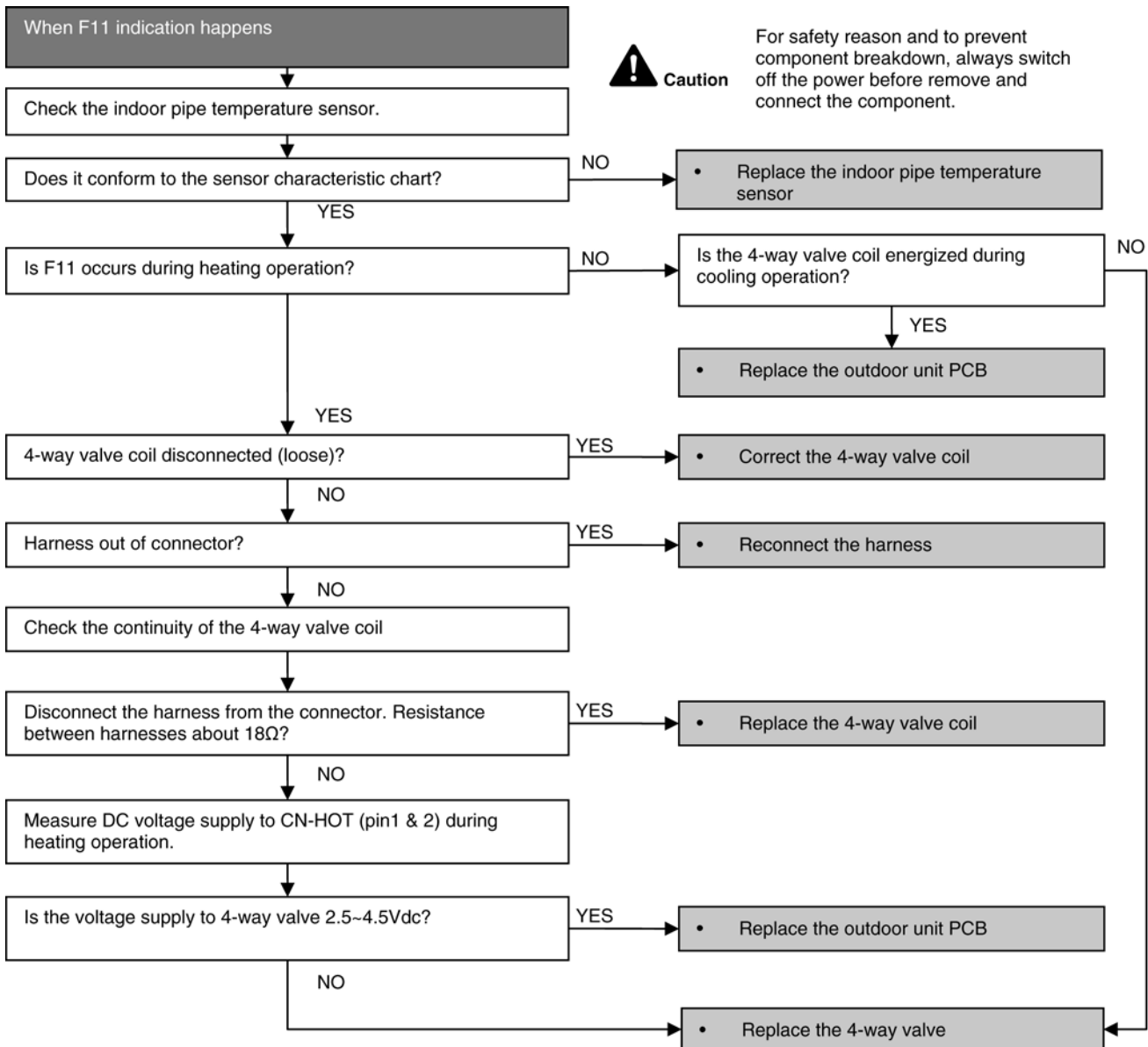

15.4.22. F17 (Indoor Standby Units Freezing Abnormality)

Malfunction Decision Conditions

- When the different between indoor intake air temperature and indoor pipe temperature is above 10°C or indoor pipe temperature is below -1.0°C

Remark:

When the indoor standby unit is freezing, the outdoor unit transfers F17 error code to the corresponding indoor unit and H39 to other indoor unit(s).

Malfunction Caused

- Wrong wiring connection
- Faulty sensor
- Faulty expansion valve

Troubleshooting

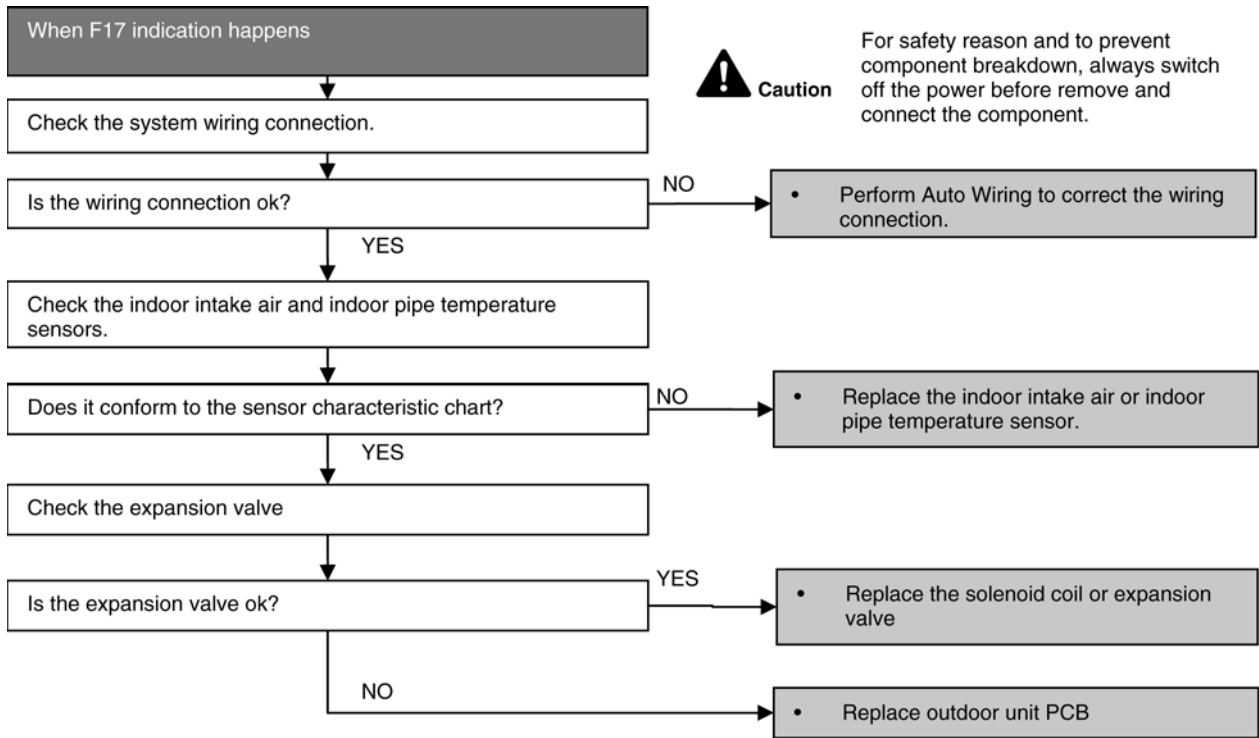

Caution

For safety reason and to prevent component breakdown, always switch off the power before remove and connect the component.

15.4.23. F90 (Power Factor Correction Protection)

Malfunction Decision Conditions

During startup and operation of cooling and heating, when Power Factor Correction (PFC) protection circuitry at the outdoor unit main PCB senses abnormal high DC voltage level.

Malfunction Caused

- DC voltage peak due to power supply surge.
- DC voltage peak due to compressor windings not uniform.
- Faulty outdoor PCB.

Troubleshooting

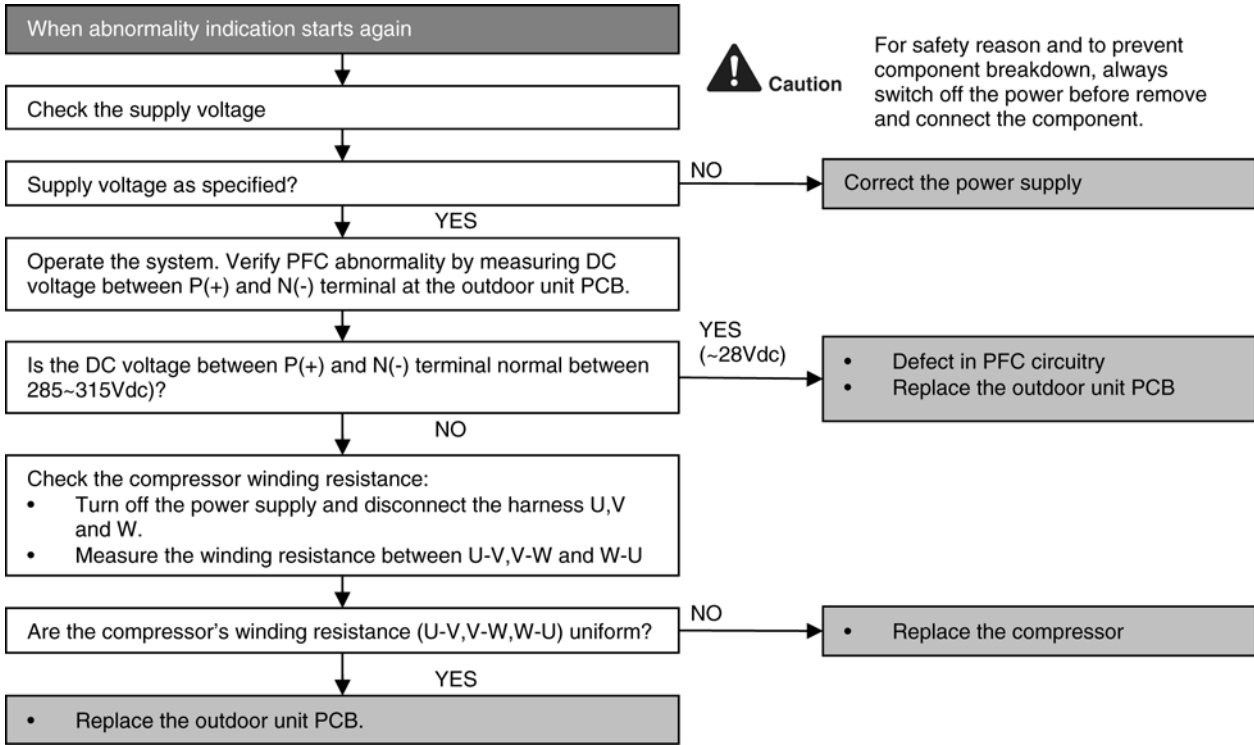

15.4.24. F91 (Refrigeration Cycle Abnormality)

Malfunction Decision Conditions

- During cooling, compressor frequency = F_{cmax}.
- During heating, compressor frequency > F_{hrated}.
- During cooling and heating operation, running current: $0.65A < I < 1.65A$.
- During cooling, indoor intake - indoor pipe < 4°C
- During heating, indoor pipe - indoor intake < 5°C

Multi Models Only

- Gas shortage detection 1: A gas shortage is detected by checking the CT-detected input current value and the compressor running frequency. During startup and operating of cooling and heating, input current < $8.78/256 (A/Hz) \times$ compressor running frequency + 0.25.
- Gas shortage detection 2: A gas shortage is detected by checking the difference between indoor pipe temperature and indoor intake air temperature during cooling and heating.

Malfunction Caused

- Refrigerant shortage (refrigerant leakage)
- Poor compression performance of compressor.
- 2/3 way valve closed.
- Detection error due to faulty indoor intake air or indoor pipe temperature sensors.

Troubleshooting

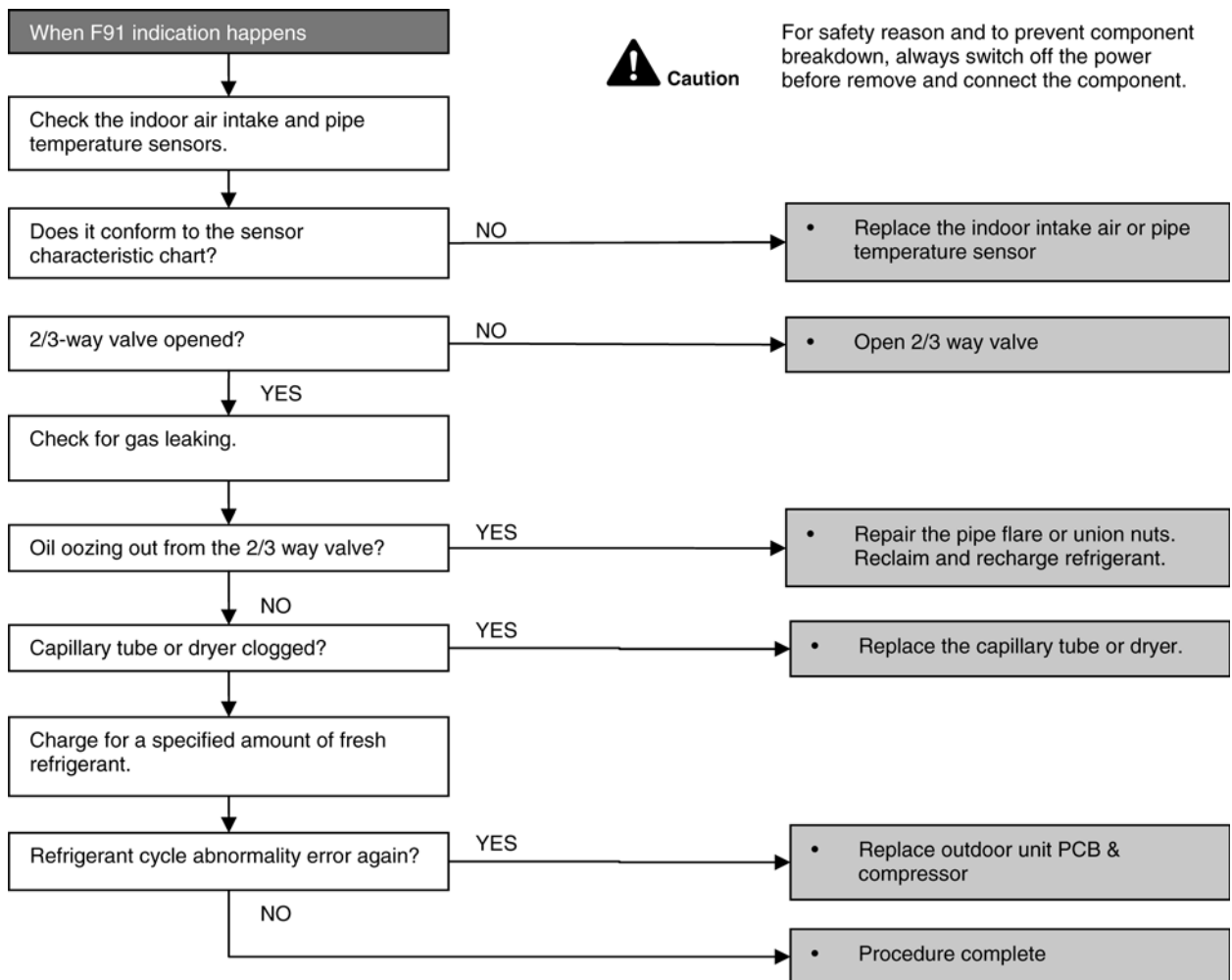

15.4.25. F93 (Compressor Rotation Failure)

Malfunction Decision Conditions

A compressor rotation failure is detected by checking the compressor running condition through the position detection circuit.

Malfunction Caused

- Compressor terminal disconnect
- Outdoor PCB malfunction

Troubleshooting

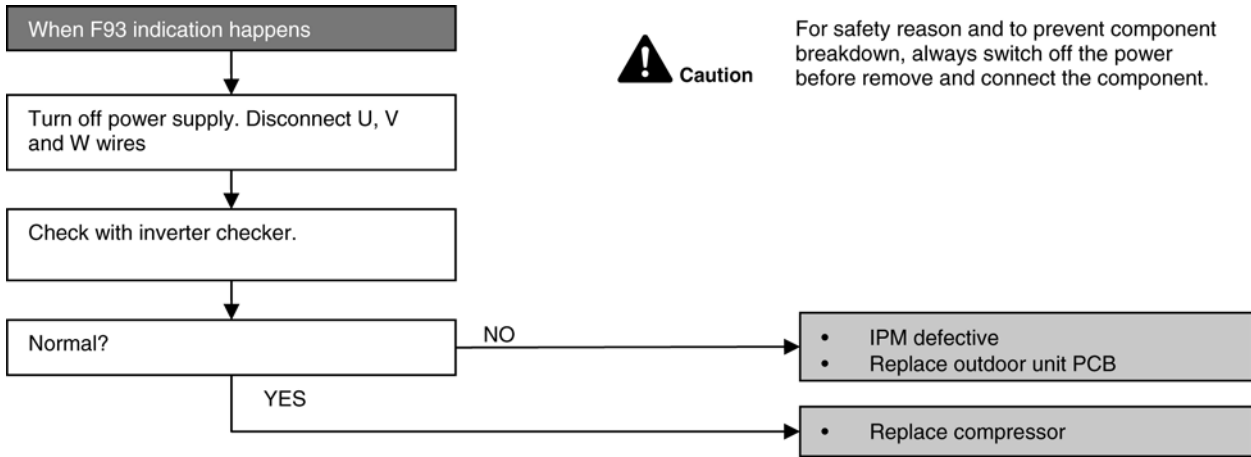

15.4.26. F95 (Cooling High Pressure Abnormality)

Malfunction Decision Conditions

During operation of cooling, when outdoor unit heat exchanger high temperature data (61°C) is detected by the outdoor pipe temperature sensor.

Malfunction Caused

- Outdoor pipe temperature rise due to short circuit of hot discharge air flow.
- Outdoor pipe temperature rise due to defective of outdoor fan motor.
- Outdoor pipe temperature rise due to defective outdoor pipe temperature sensor.
- Outdoor pipe temperature rise due to defective outdoor unit PCB.

Troubleshooting

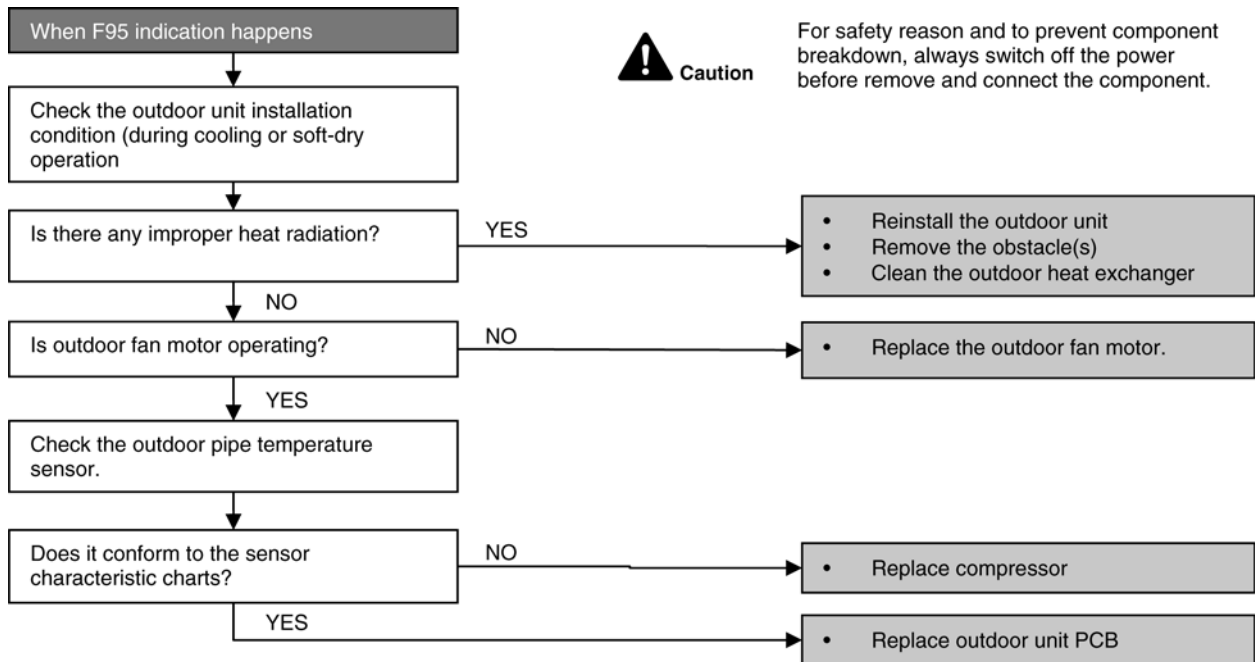

15.4.27. F96 (IPM Overheating)

Malfunction Decision Conditions

During operating of cooling and heating, when IPM temperature data (100°C) is detected by the IPM temperature sensor.

Multi Models Only

- Compressor Overheating: During operation of cooling and heating, when the compressor OL is activated.
- Heat Sink Overheating: During operation of cooling and heating, when heat sink temperature data (90°C) is detected by the heat sink temperature sensor.

Malfunction Caused

- IPM overheats due to short circuit of hot discharge air flow.
- IPM overheats due to defective of outdoor fan motor.
- IPM overheats due to defective of internal circuitry of IPM.
- IPM overheats due to defective IPM temperature sensor.

Multi Models Only

- Compressor OL connector poor contact.
- Compressor OL faulty.

Troubleshooting

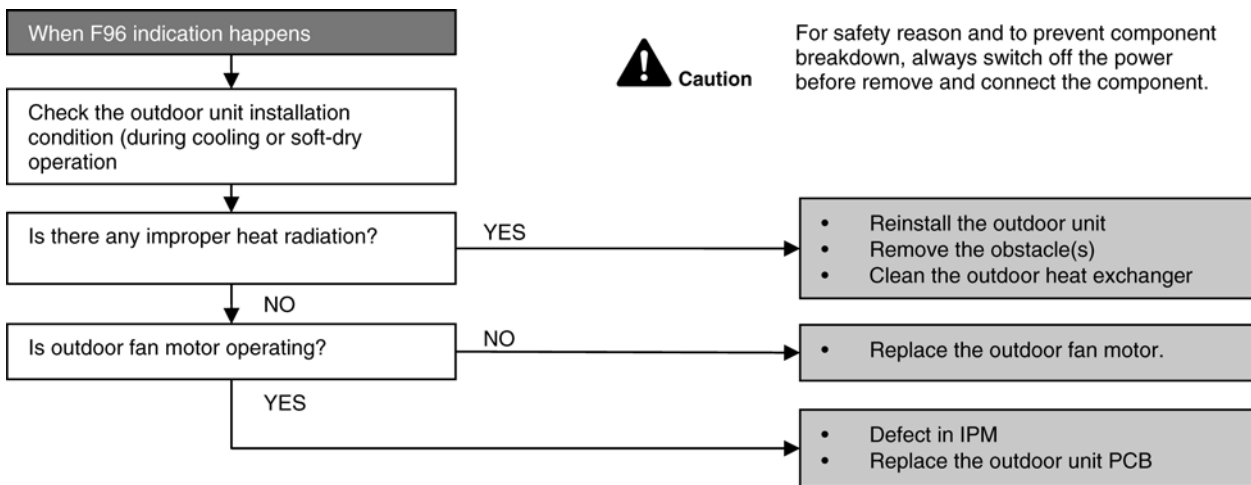

15.4.28. F97 (Compressor Overheating)

Malfunction Decision Conditions

During operation of cooling and heating, when compressor tank temperature data (112°C) is detected by the compressor tank temperature sensor.

Malfunction Caused

- Refrigerant shortage (refrigerant leakage).
- 2/3 way valve closed.
- Detection error due to faulty compressor tank temperature sensor.

Troubleshooting

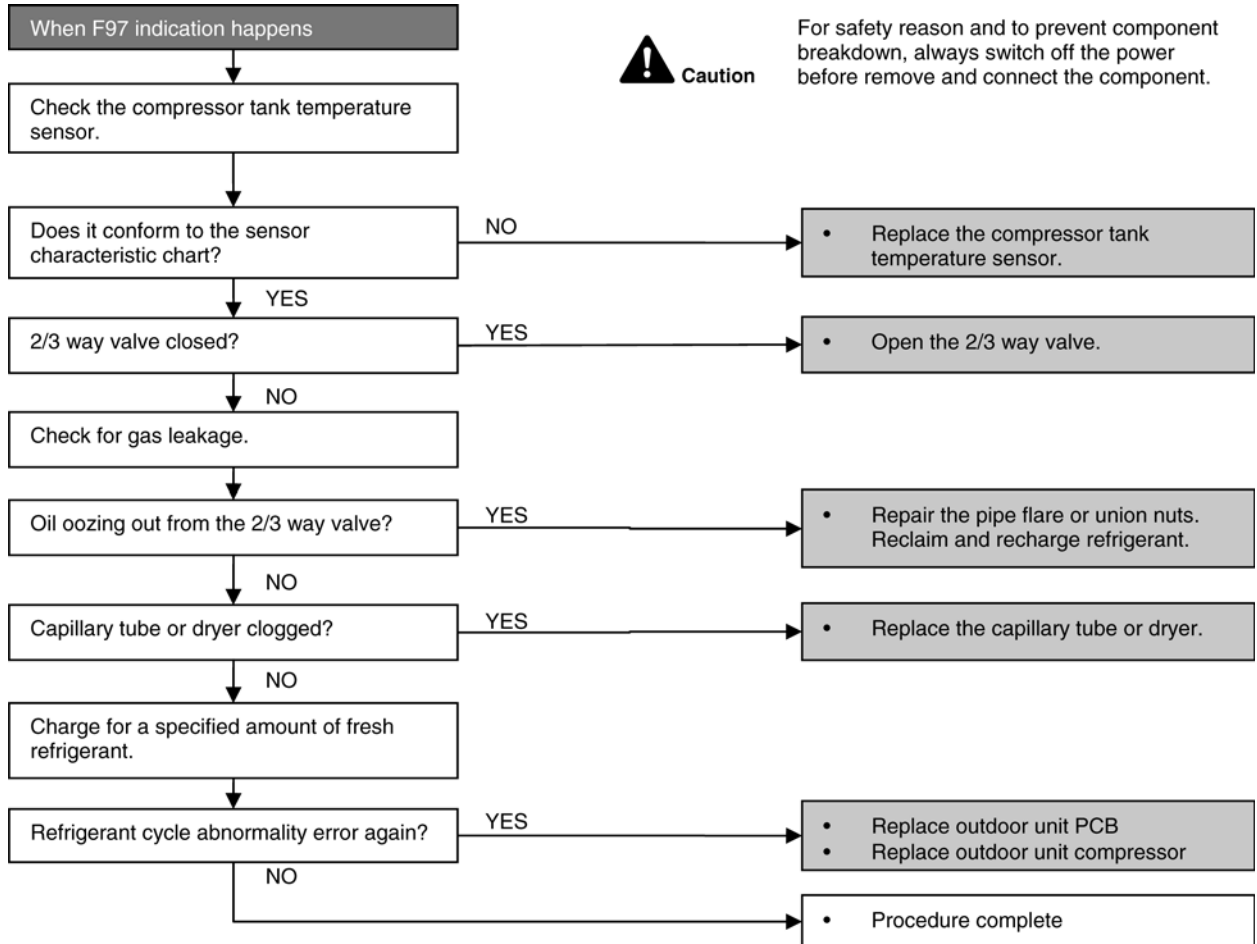

15.4.29. F98 (Input Over Current Detection)

Malfunction Decision Conditions

During operation of cooling and heating, when an input over-current (16.8A) is detected by checking the input current value being detected by current transformer (CT) with the compressor running.

Malfunction Caused

- Over-current due to compressor failure.
- Over-current due to defective outdoor unit PCB.
- Over-current due to defective inverter main circuit electrolytic capacitor.
- Over-current due to excessive refrigerant.

Troubleshooting

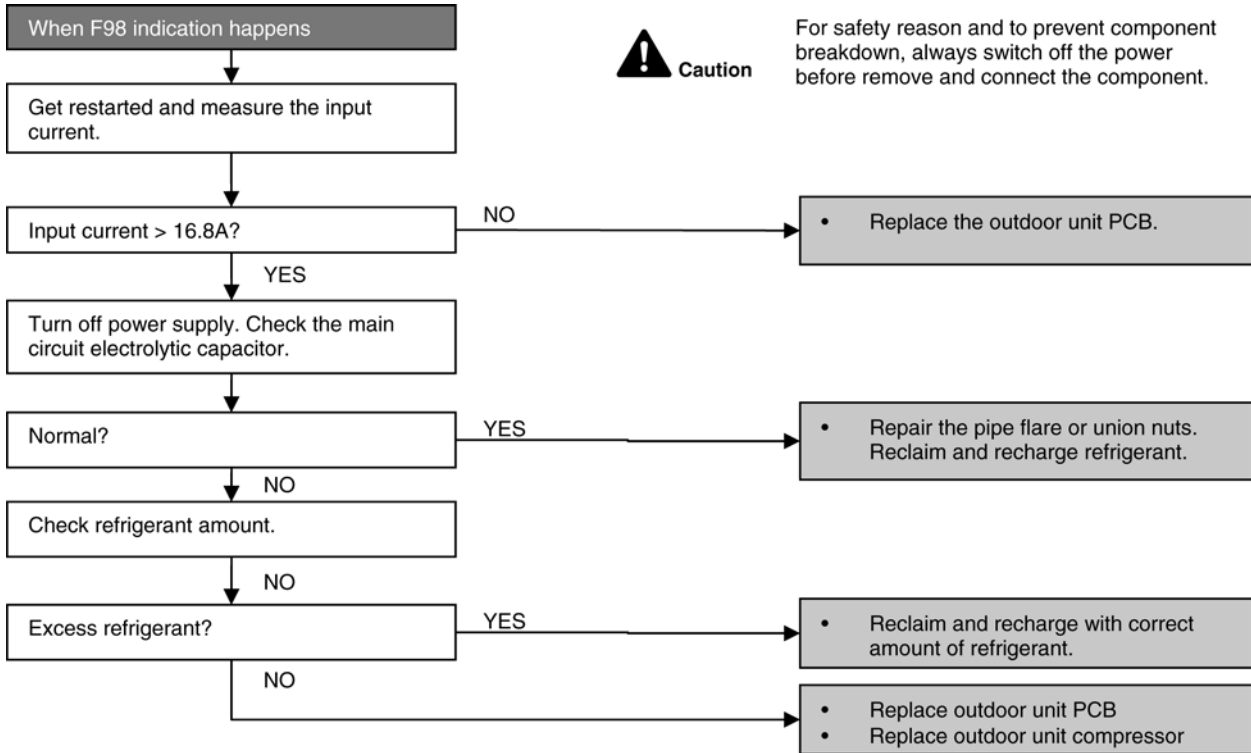

15.4.30. F99 (Output Over Current Detection)

Malfunction Decision Conditions

During operation of cooling and heating, when an output over-current (18.5A) is detected by checking the current that flows in the inverter DC peak sensing circuitry.

Malfunction Caused

- DC peak due to compressor failure.
- DC peak due to defective power transistor(s).
- DC peak due to defective outdoor unit PCB.

Troubleshooting

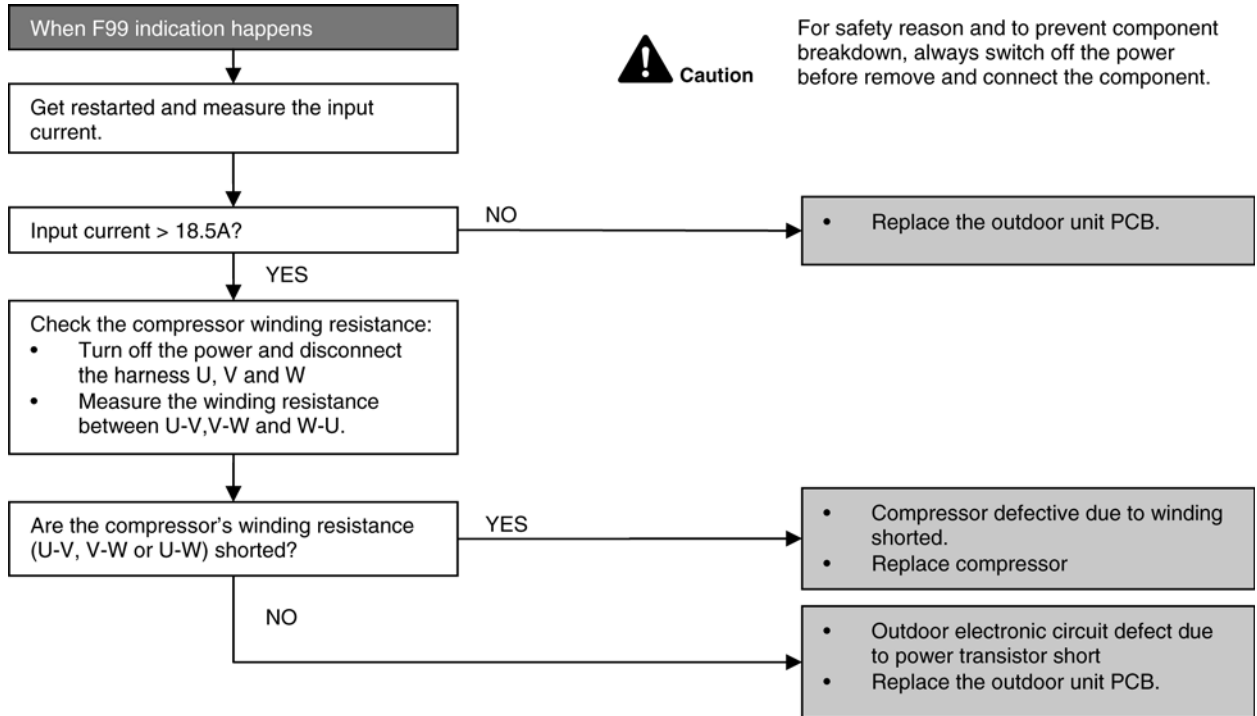

- Checking the power transistor
- Never touch any live parts for at least 10 minutes after turning off the circuit breaker.
- If unavoidable necessary to touch a live part, make sure the power transistor's supply voltage is below 50V using the tester.
- For the UVW, make measurement at the Faston terminal on the board of the relay connector.

Tester's negative terminal	Power transistor (+)	UVW	Power transistor (-)	UVW
Tester's positive terminal	UVW	Power transistor (+)	UVW	Power transistor (-)
Normal resistance	Several kΩ to several MΩ			
Abnormal resistance	0 or ∞			

16 Disassembly and Assembly Instructions

WARNING

High voltages are generated in the electrical parts area by the capacitor. Ensure that the capacitor has discharged sufficiently before proceeding with repair work. Failure to heed this caution may result in electric shocks.

16.1. Indoor Electronic Controllers, Cross Flow Fan and Indoor Fan Motor Removal Procedures

16.1.1. To remove front grille

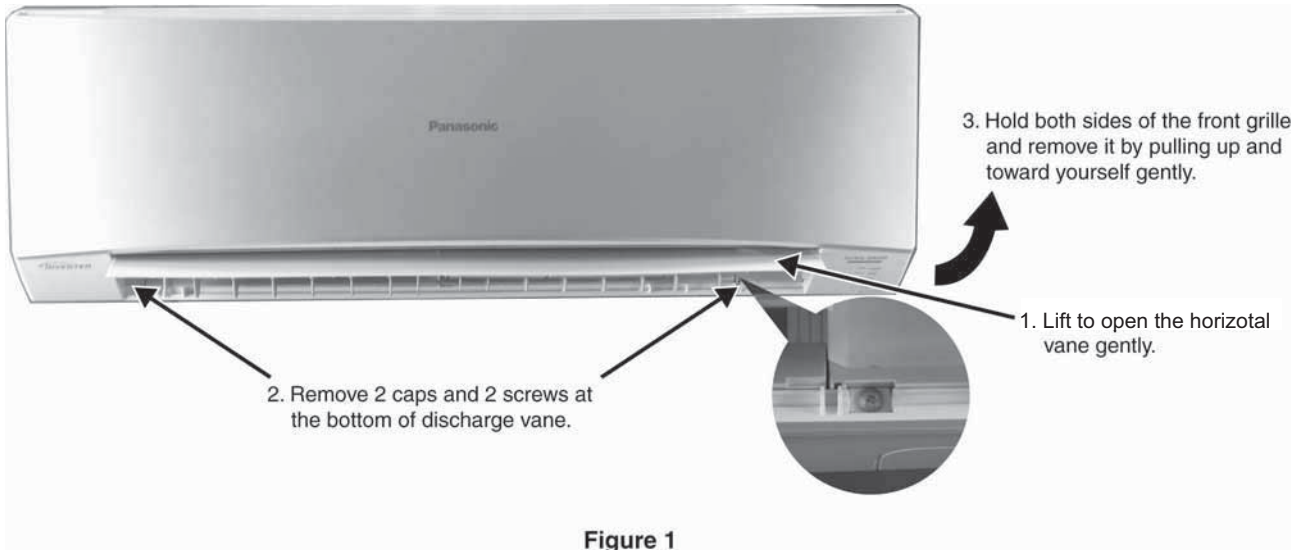

16.1.2. To remove power electronic controller

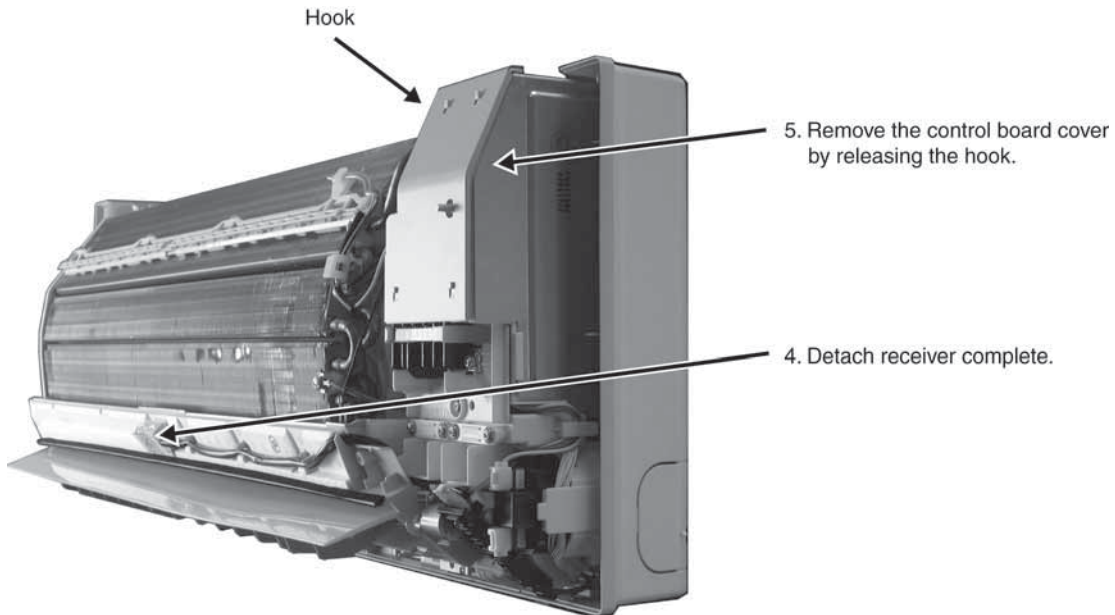

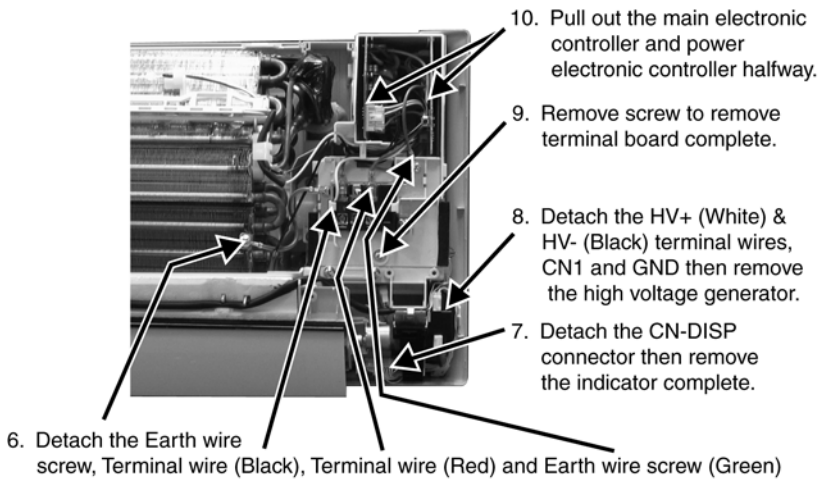

Figure 3

11. Detach 4 connectors as labeled from the electronic controller. Then pull out main controller gently.

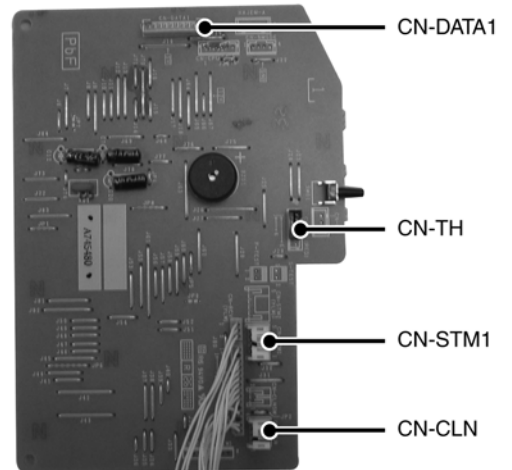

Figure 4

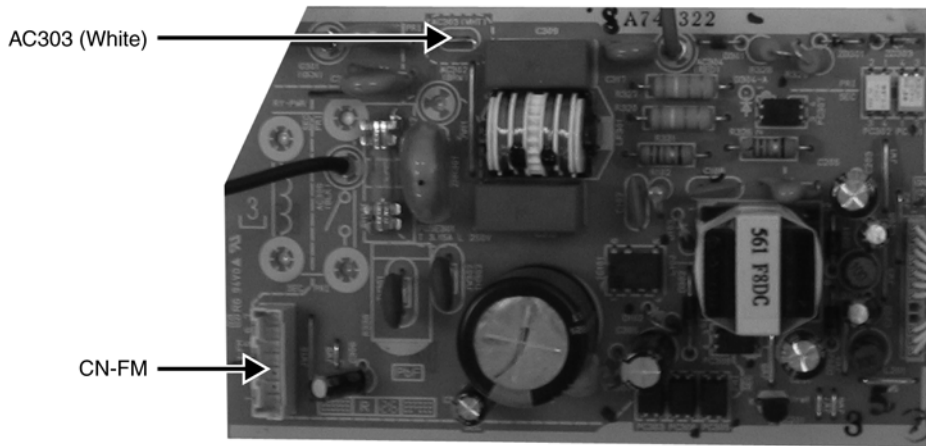

Figure 5

12. Detach the AC303 and CN-FM connectors from the electronic controller. Then, pull out power electronic controller gently.

16.1.3. To remove discharge grille

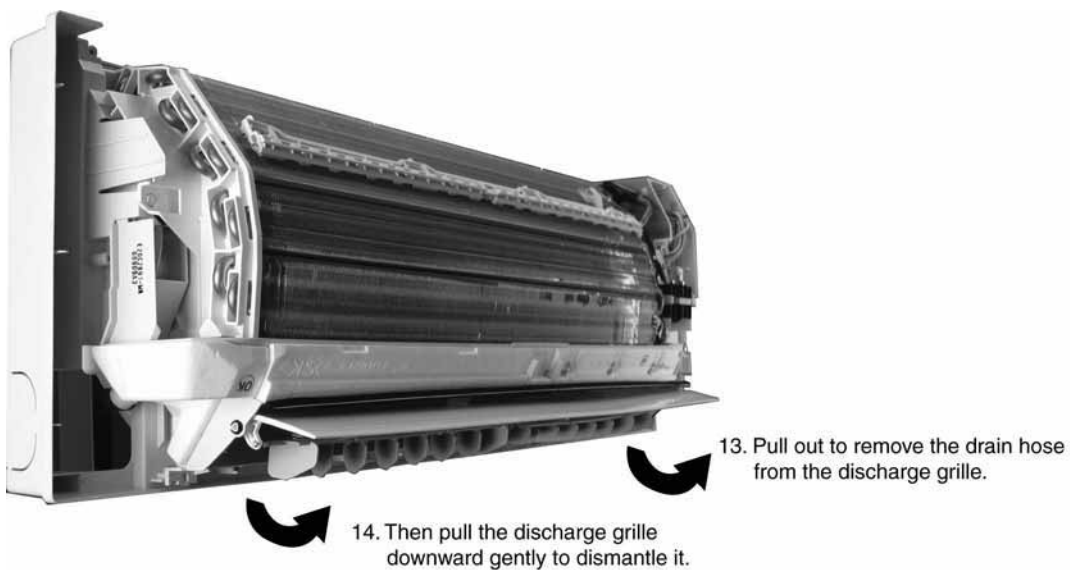

Figure 6

16.1.4. To remove control board

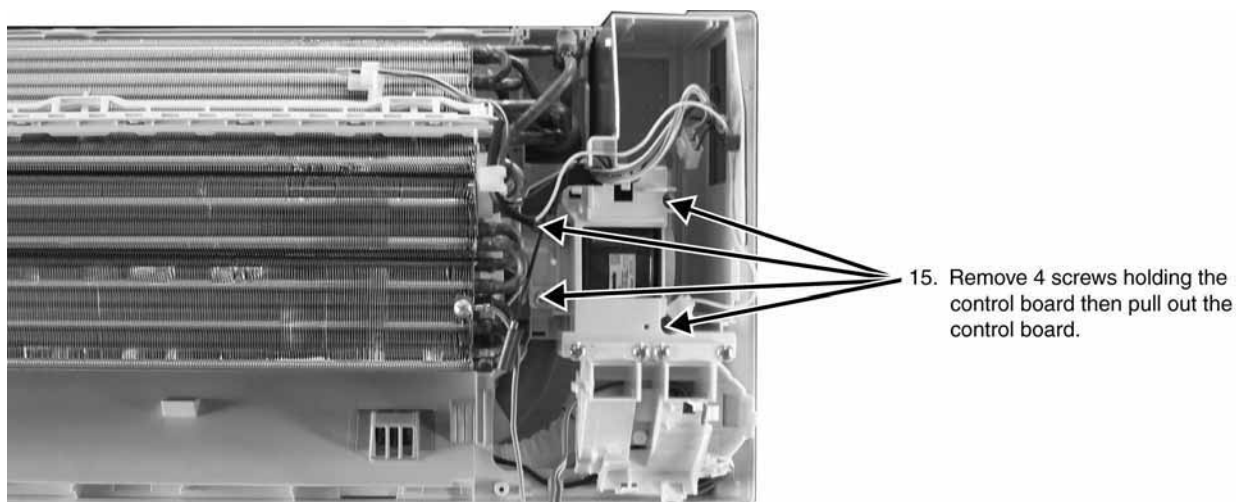

Figure 7

16.1.5. To remove cross flow fan and indoor fan motor



Figure 8

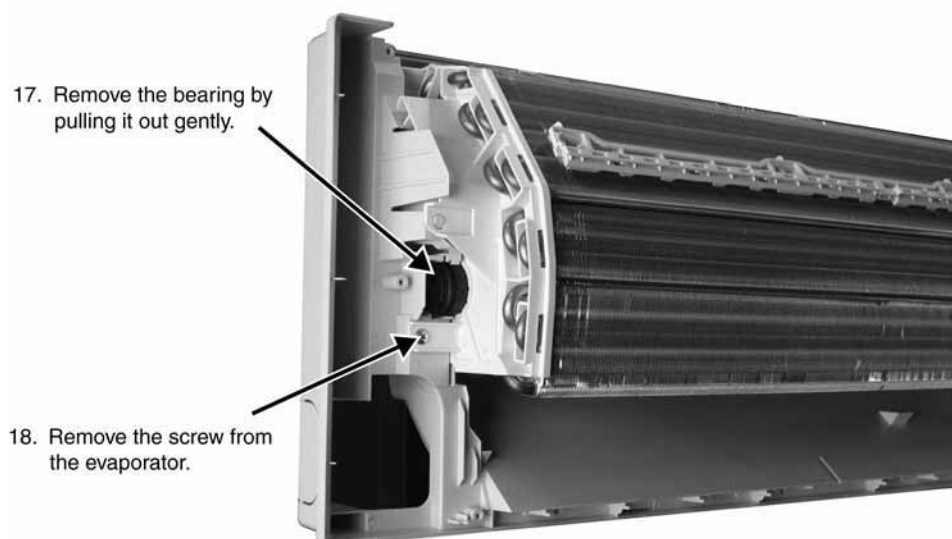

Figure 9

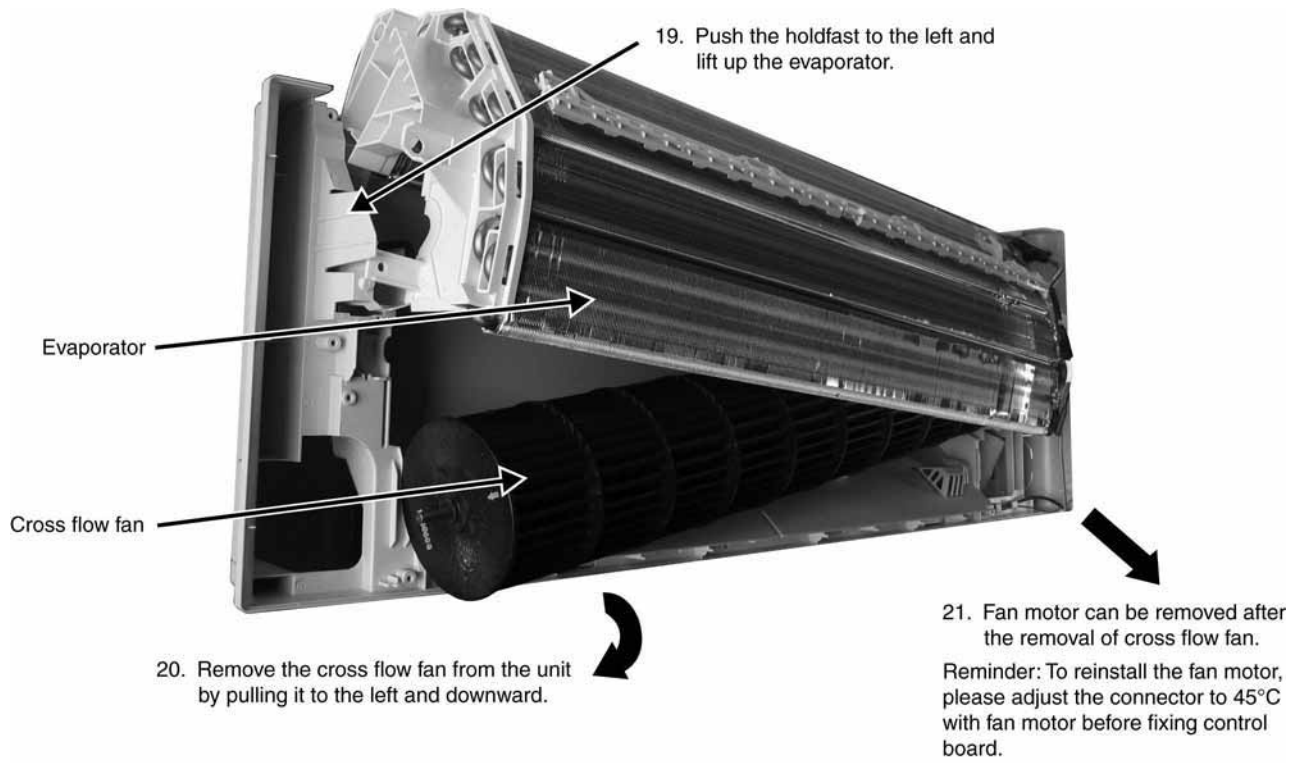

Figure 10

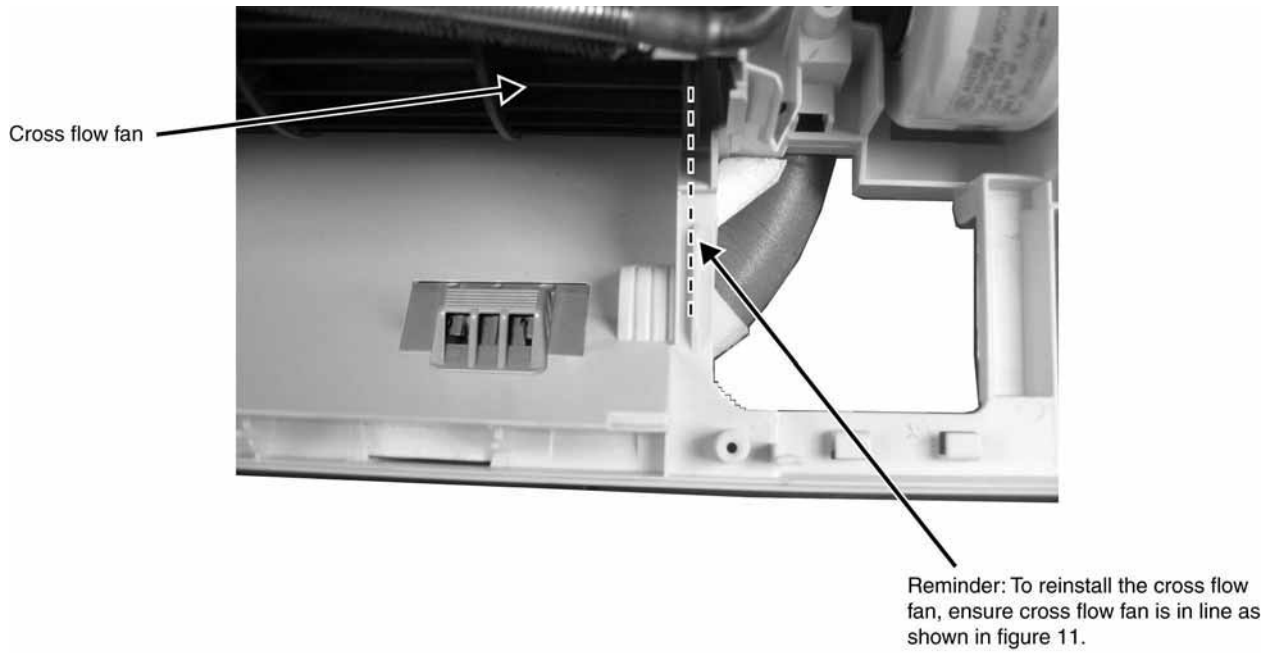



Figure 11

16.2. Outdoor Electronic Controller Removal Procedure

16.2.1. CU-E7JKE CU-E9JKE CU-E12JKE CU-E15JKE-1 CU-E7JKE-3 CU-E9JKE-3 CU-E12JKE-3

 Caution! When handling electronic controller, be careful of electrostatic discharge.

1. Remove the 3 screws of the Top Panel.

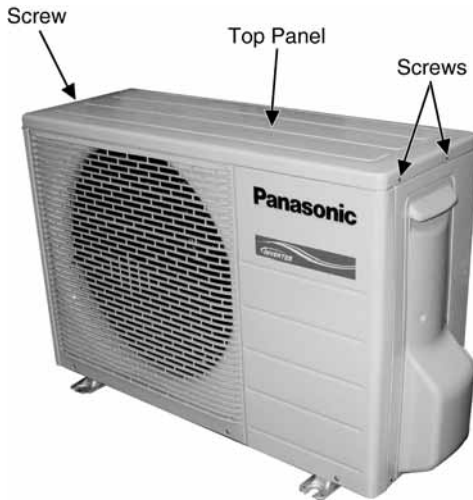

Fig. 1

2. Remove the 6 screws of the Front Panel.

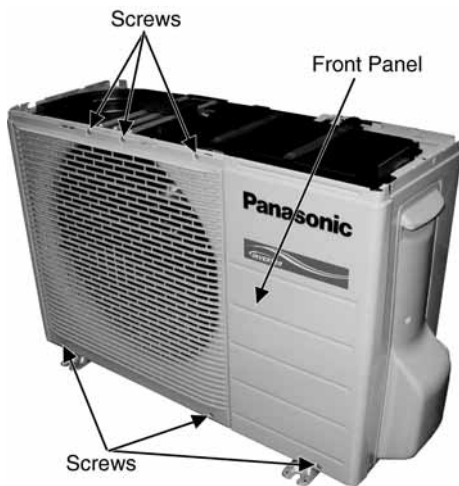

Fig. 2

3. Remove the screw of the Terminal Board Cover.

4. Remove the Top Cover of the Control Board by 4 hooks.

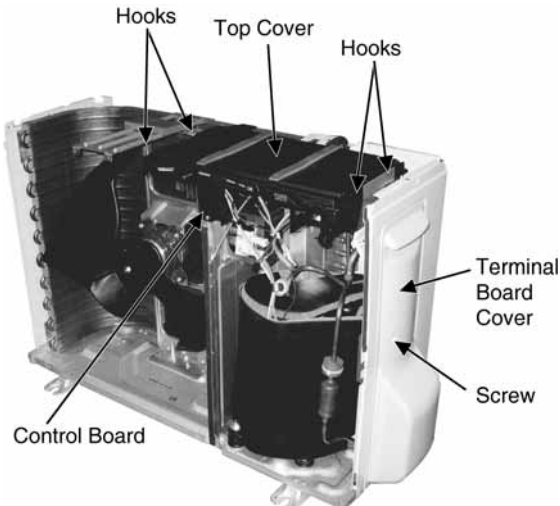

Fig. 3

5. Remove the Control Board as follows:

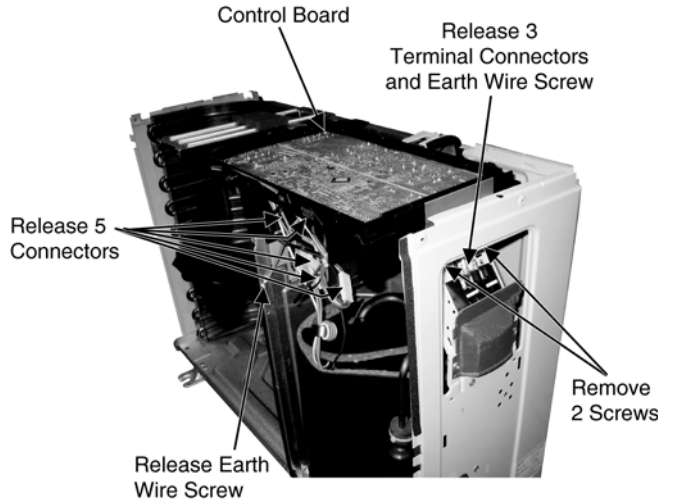

Fig. 4

Remove the Terminal Cover and 3 Terminal Compressor

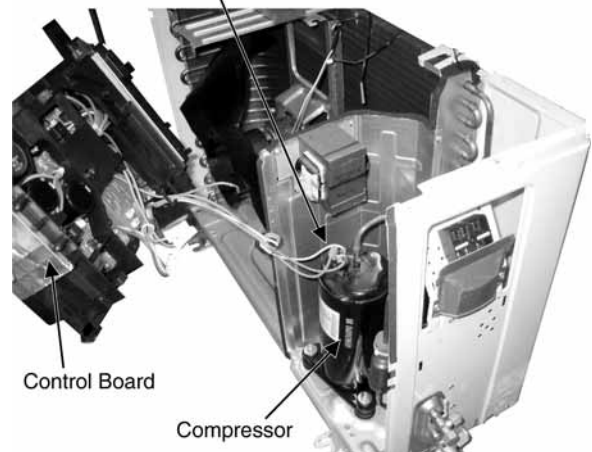

Fig. 5

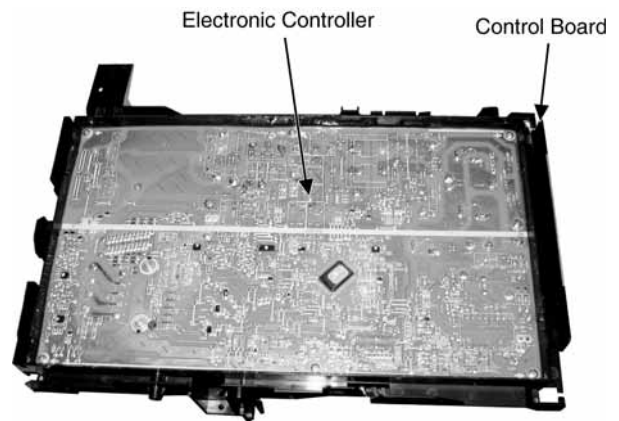

Fig. 6

16.2.2. CU-E15JKE

1. Remove the 4 screws of the Top Panel.



Fig. 1

2. Remove the 10 screws of the Front Panel.

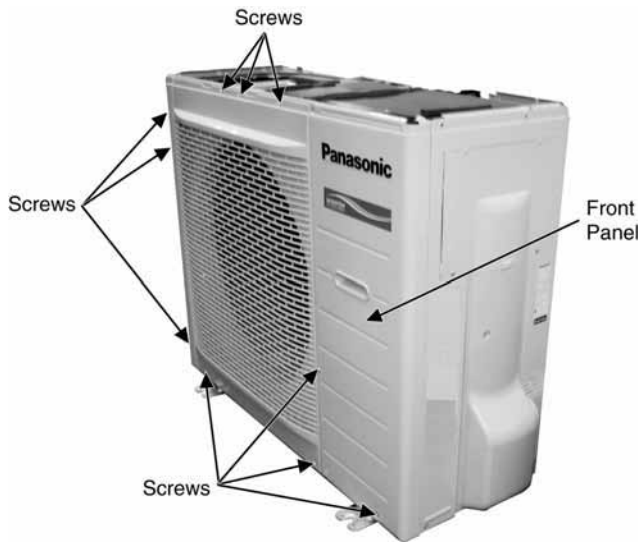

Fig. 2

3. Remove the Top Cover of the Electronic Controller.



Fig. 3

4. Remove the Control Board.

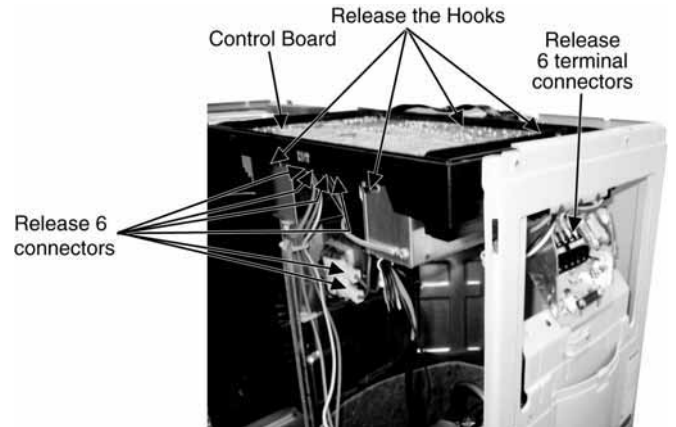

Fig. 4

5. Remove the 8 screws of the Electronic Controller.

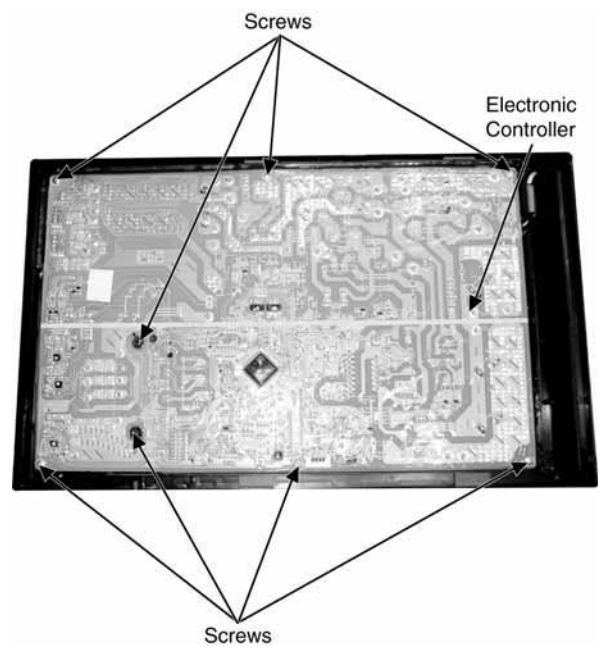

Fig. 5

⚠ Caution! When handling electronic controller, be careful of electrostatic discharge.

17 Technical Data

17.1. Operation Characteristics

17.1.1. CU-E7JKE

• Cooling Characteristic

[Condition] Indoor temperature: 27/19°C
Remote condition: High fan speed, Cool 16°C
Comp. Hz: F_c
Voltage: 230V

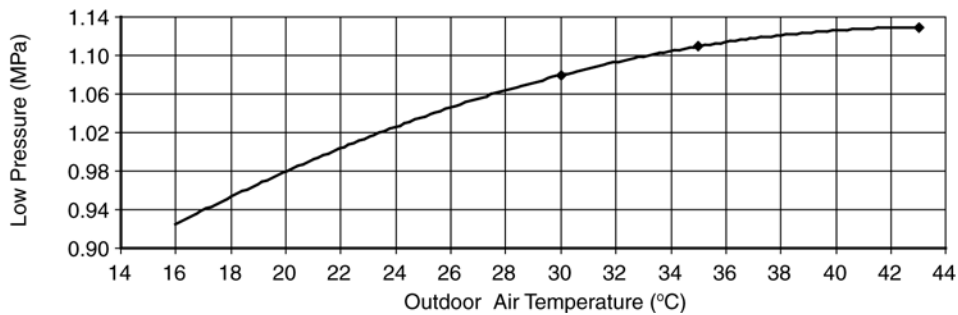
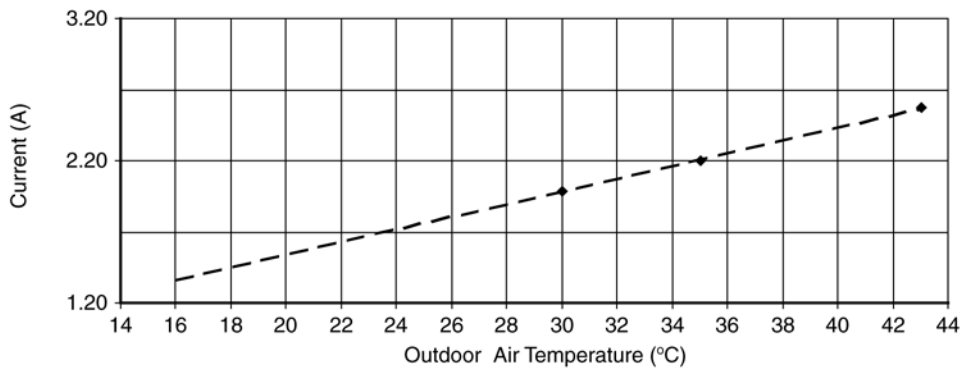
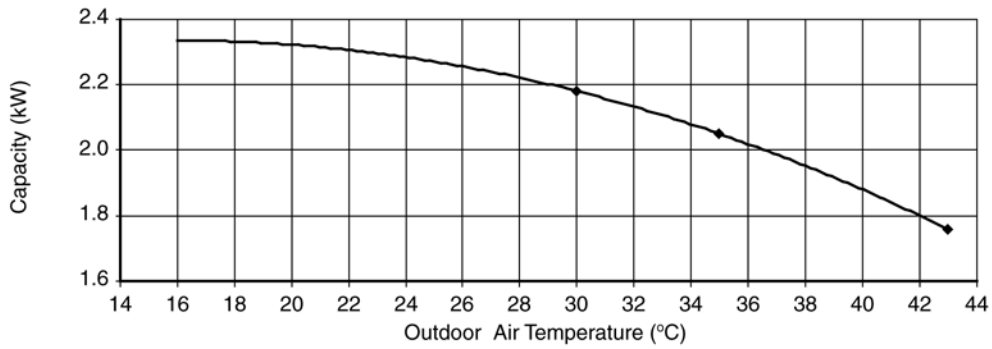
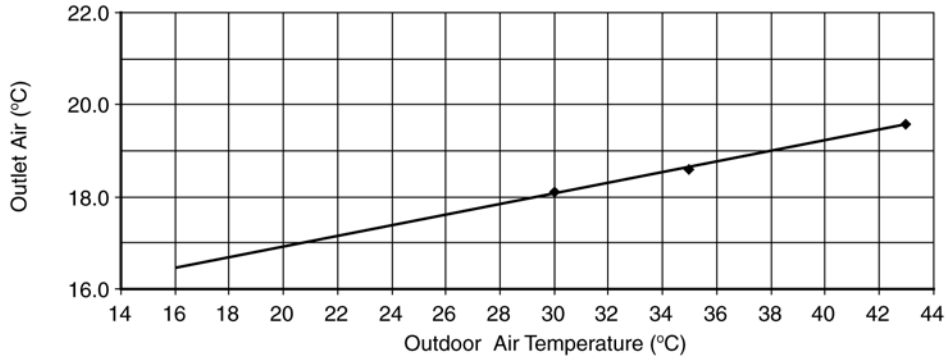

• Piping Length Characteristic

[Condition] Indoor temperature: 27/19°C, 35/-°C
 Remote condition: High fan speed, Cool 16°C
 Comp. Hz: F_c
 Voltage: 230V

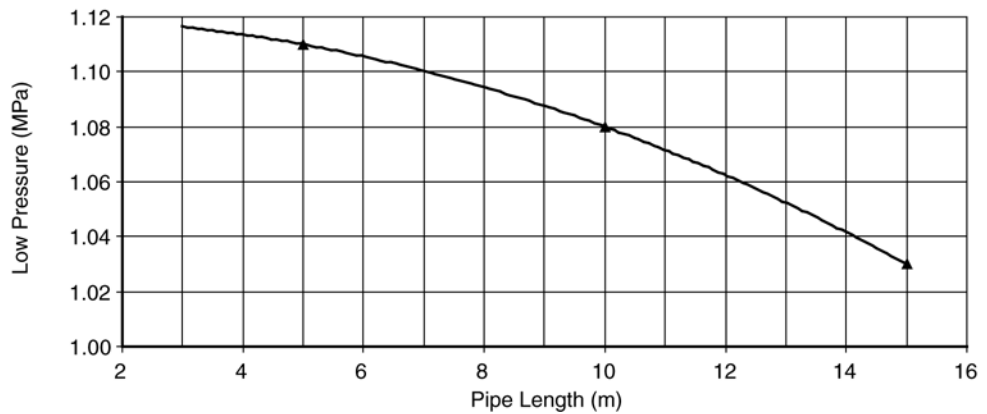
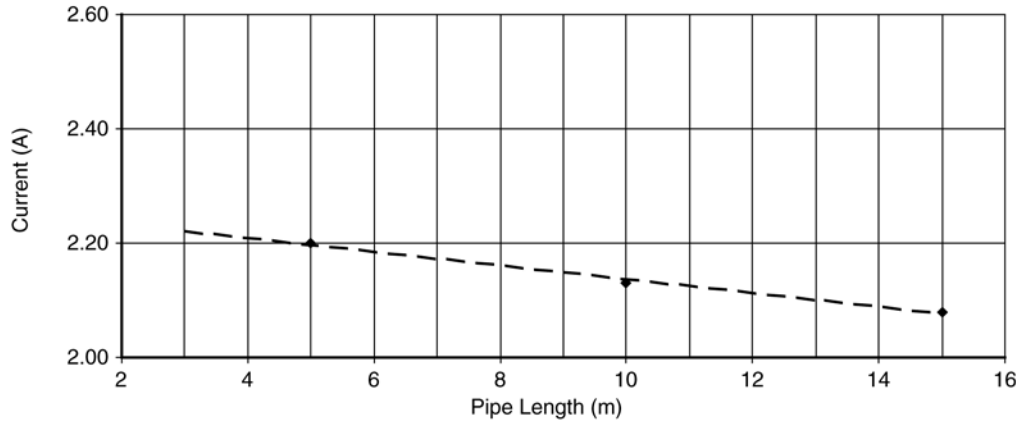
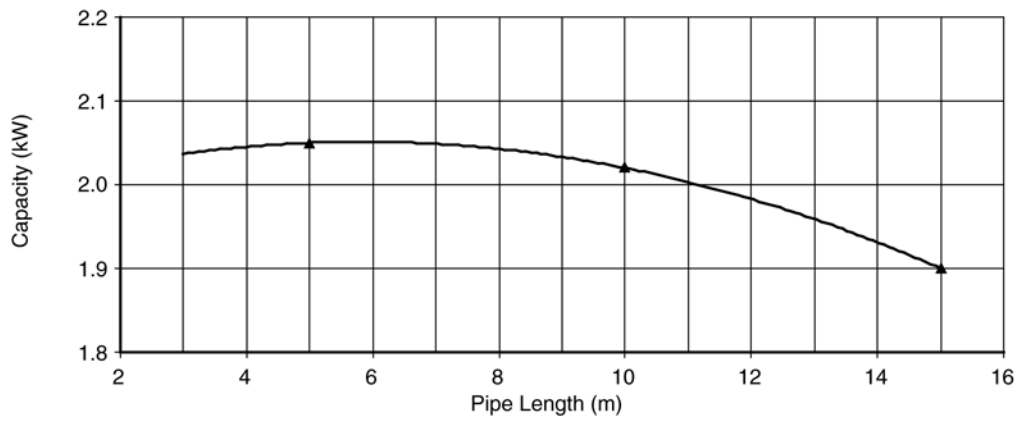
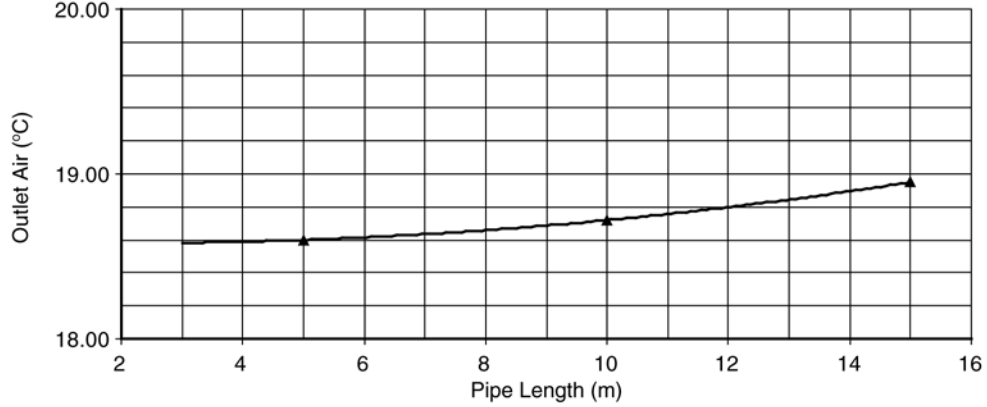

• Heating Characteristic

[Condition] Indoor temperature: 20/-°C

Remote condition: High fan speed, Heat 30°C

Comp. Hz: F_h

Voltage: 230V

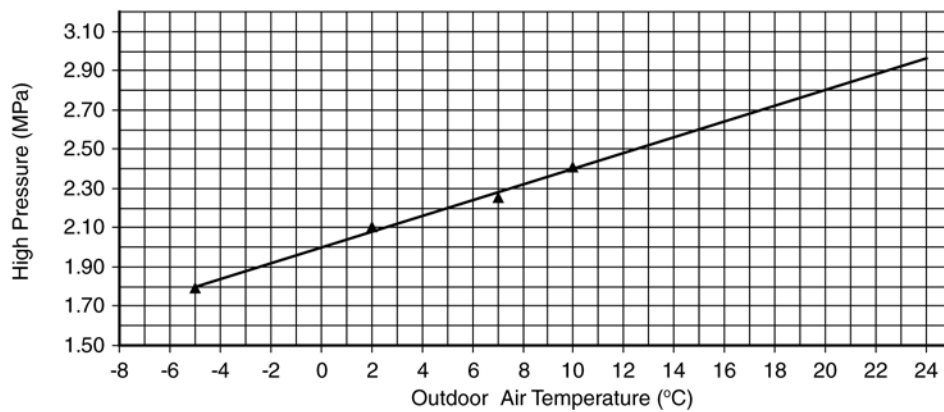
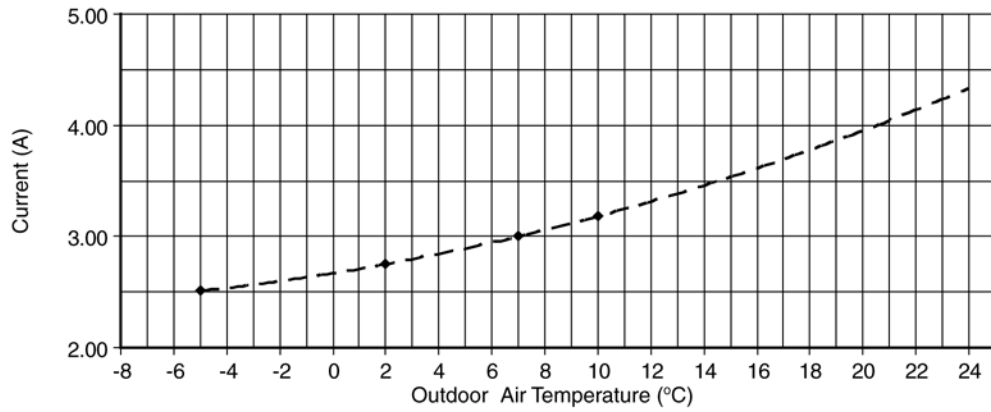
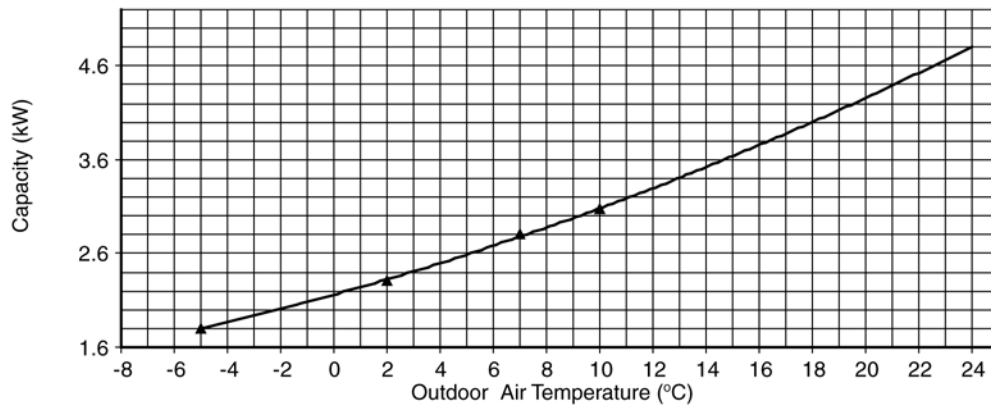
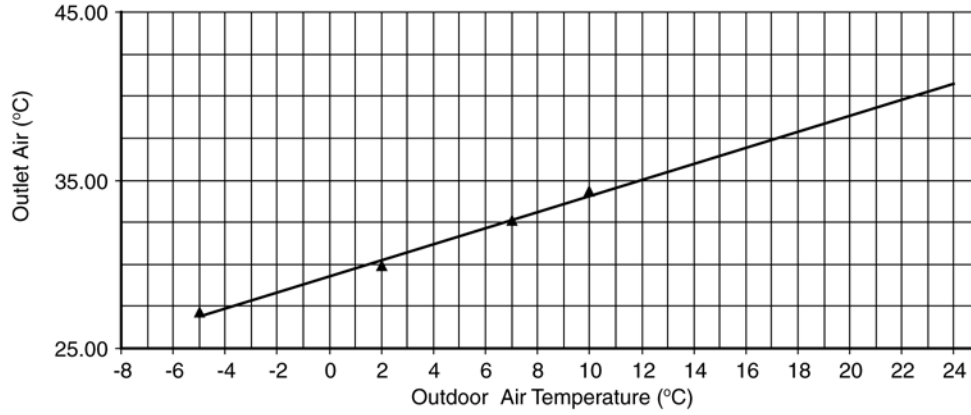

• Piping Length Characteristic

[Condition] Indoor temperature: 20/-°C, 7/6°C
 Remote condition: High fan speed, Heat 30°C
 Comp. Hz: F_h
 Voltage: 230V

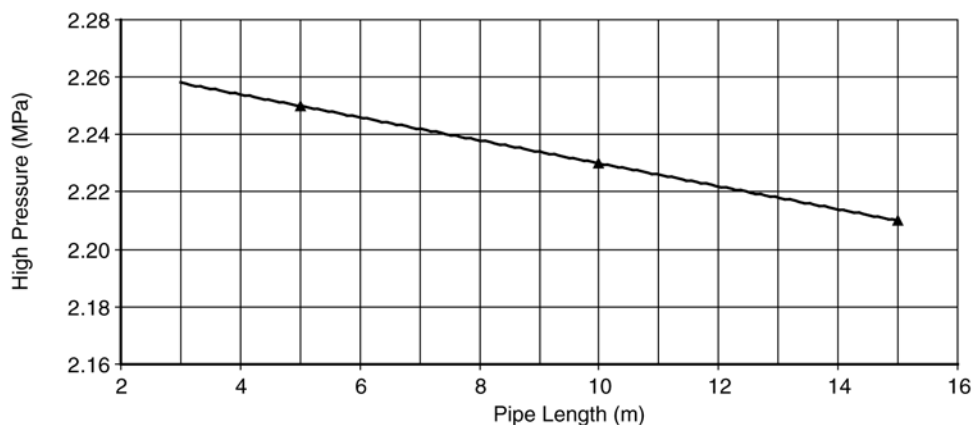
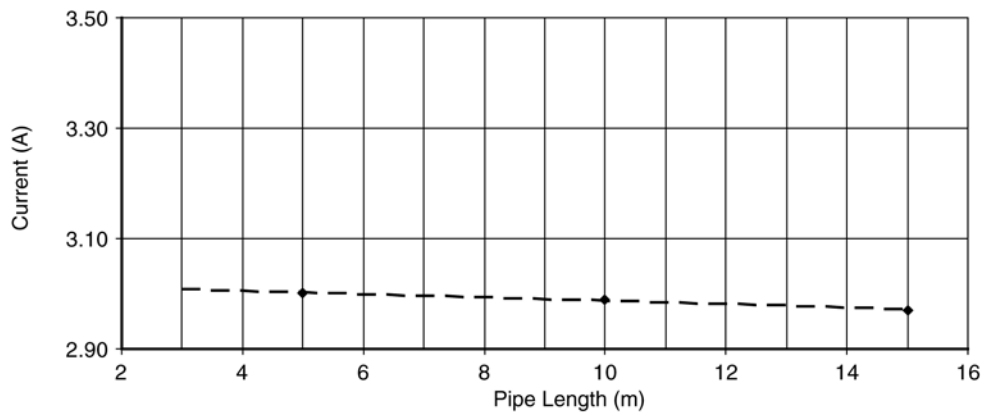
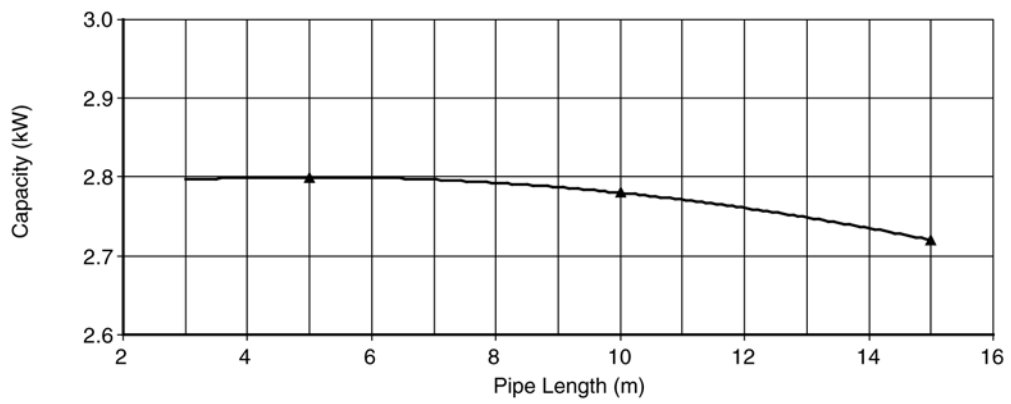
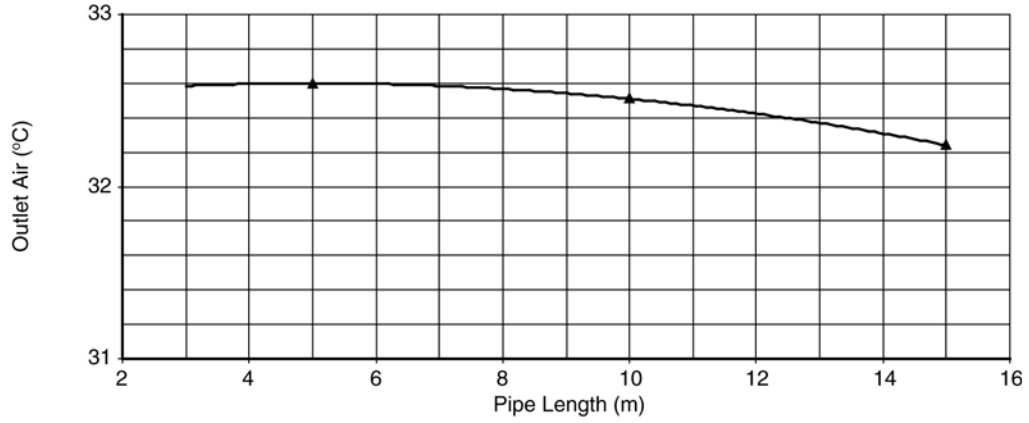

17.1.2. CU-E9JKE

• Cooling Characteristic

[Condition] Indoor temperature: 27/19°C
Remote condition: High fan speed, Cool 16°C
Comp. Hz: F_c
Voltage: 230V

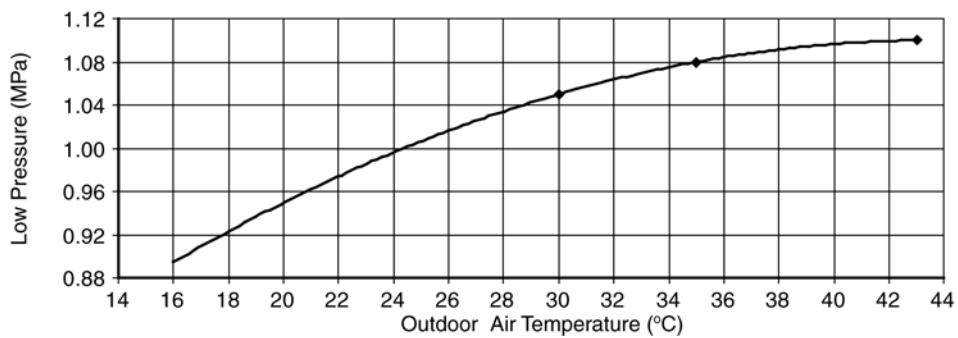
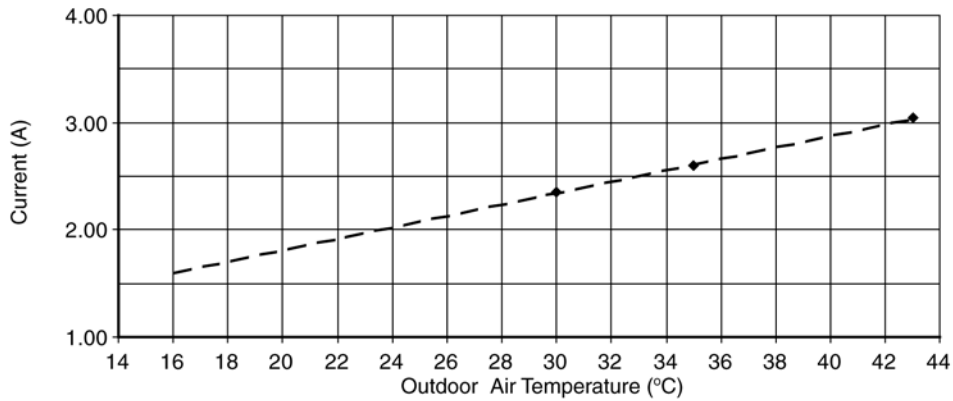
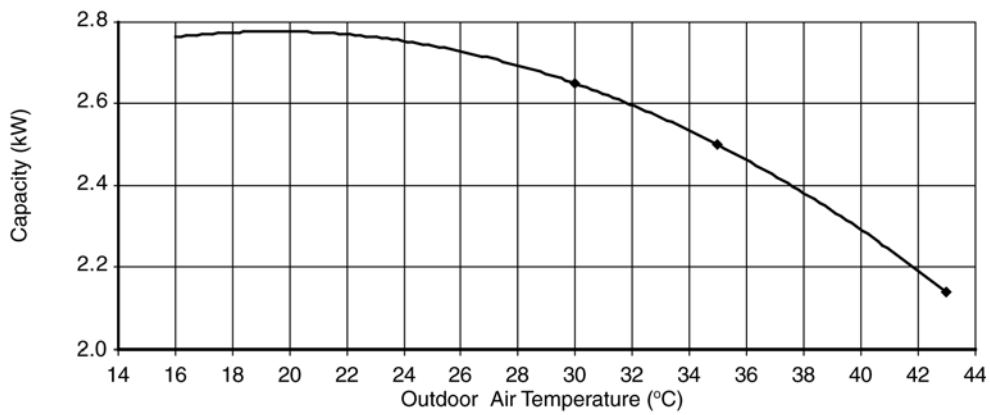
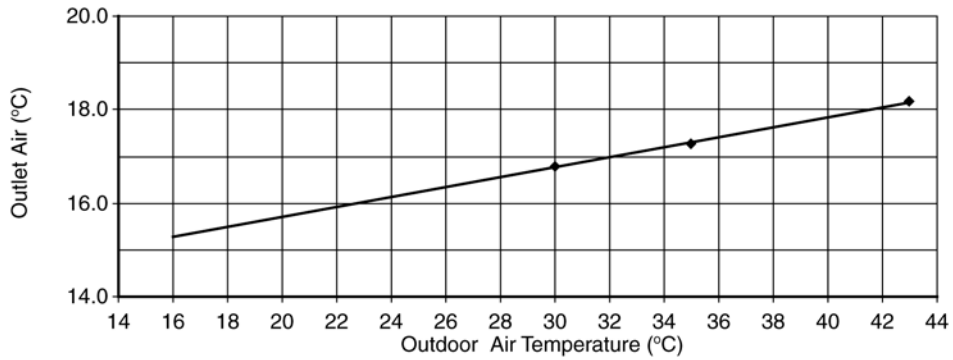

• Piping Length Characteristic

[Condition] Indoor temperature: 27/19°C, 35/-°C
 Remote condition: High fan speed, Cool 16°C
 Comp. Hz: F_c
 Voltage: 230V

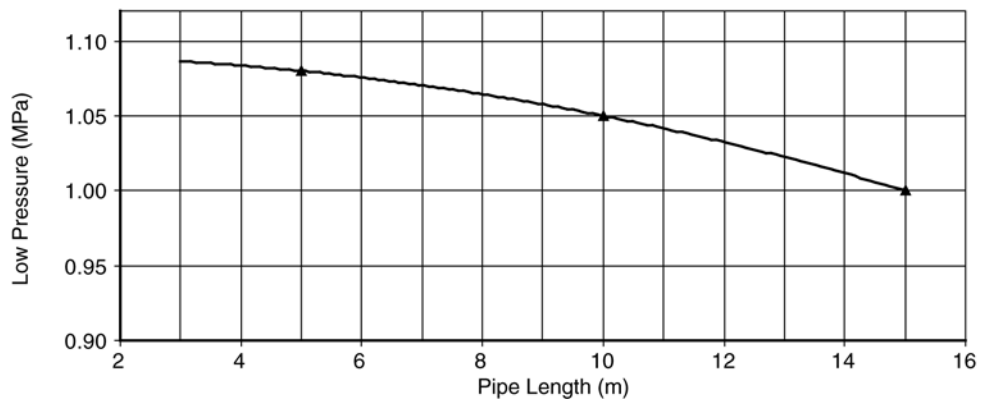
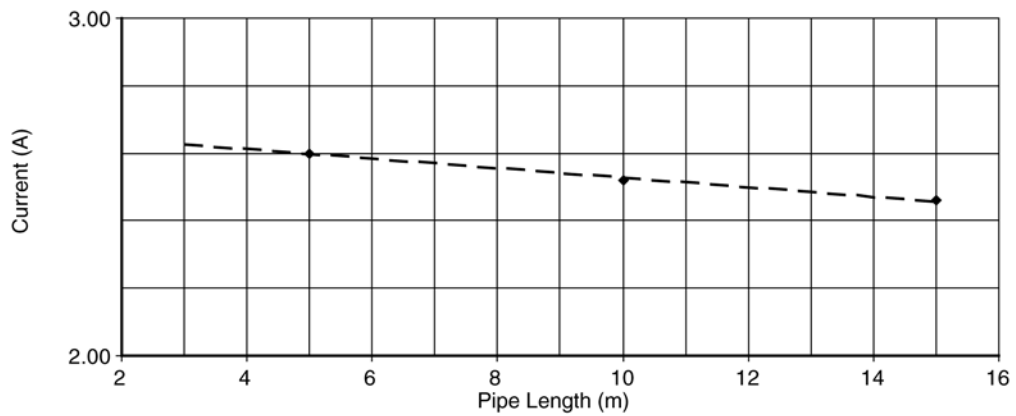
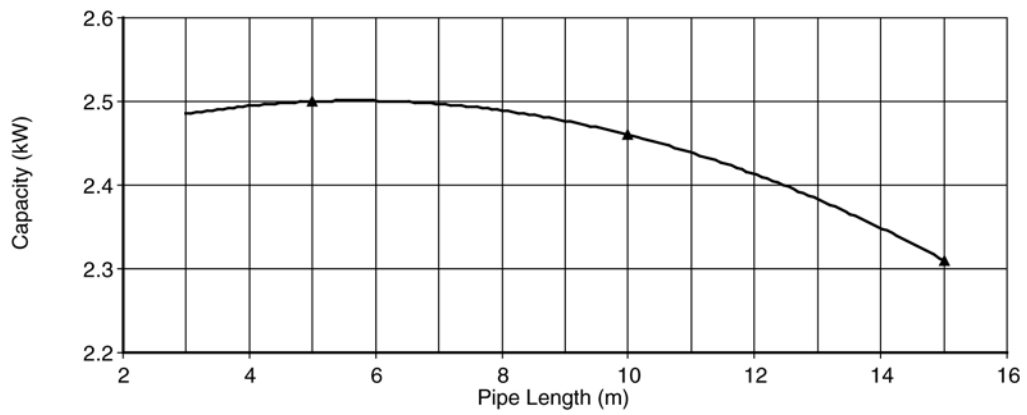
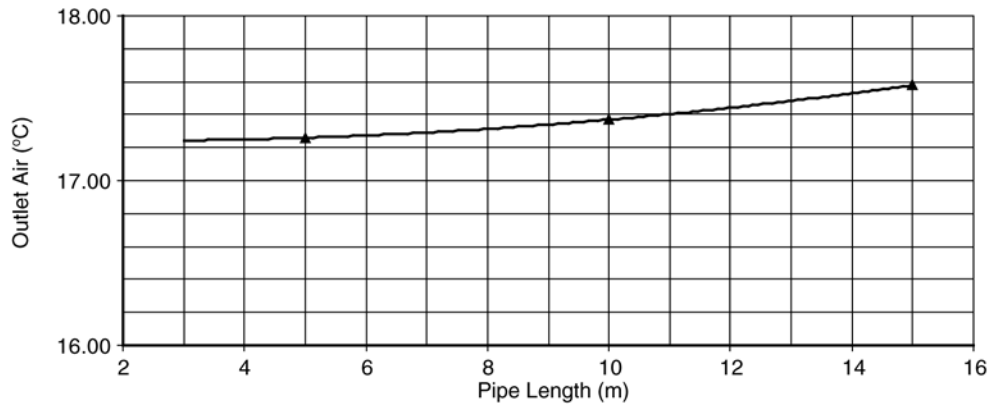

• Heating Characteristic

[Condition] Indoor temperature: 20/-°C

Remote condition: High fan speed, Heat 30°C

Comp. Hz: F_h

Voltage: 230V

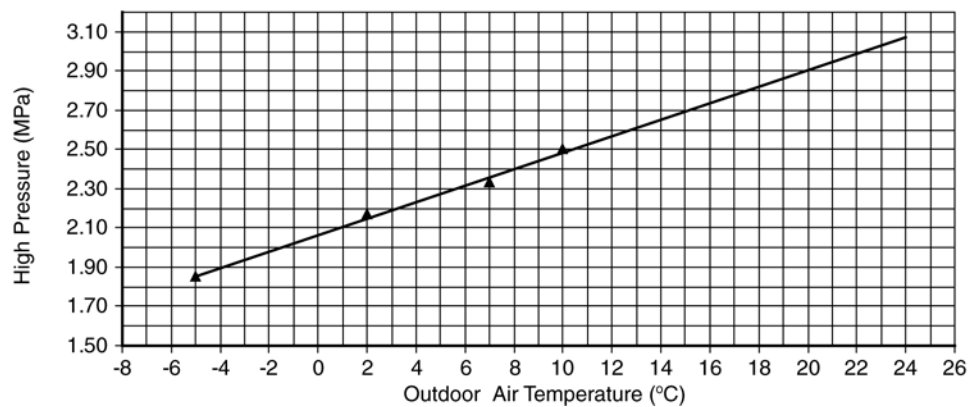
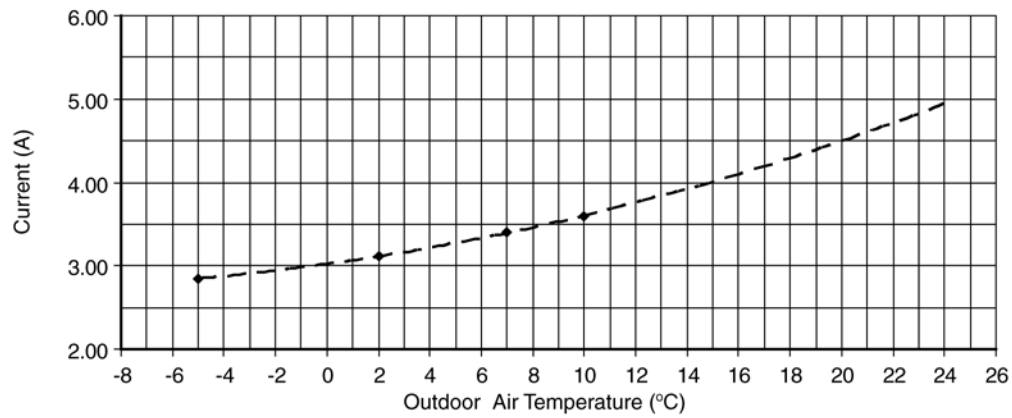
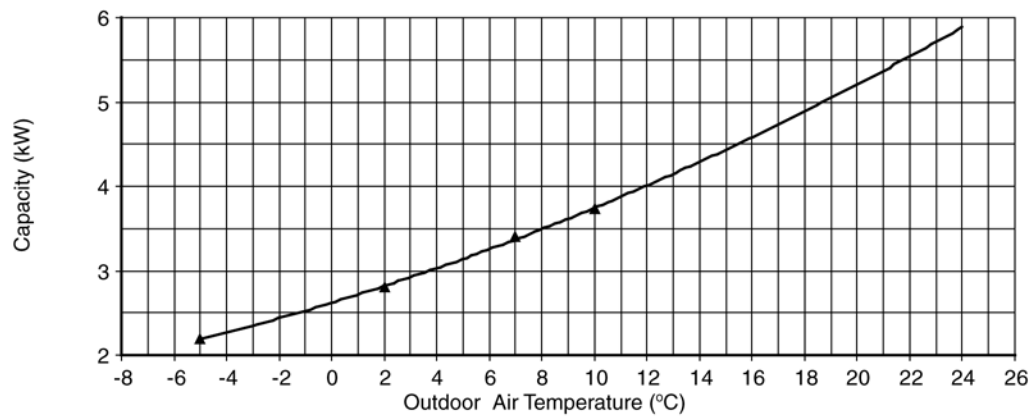
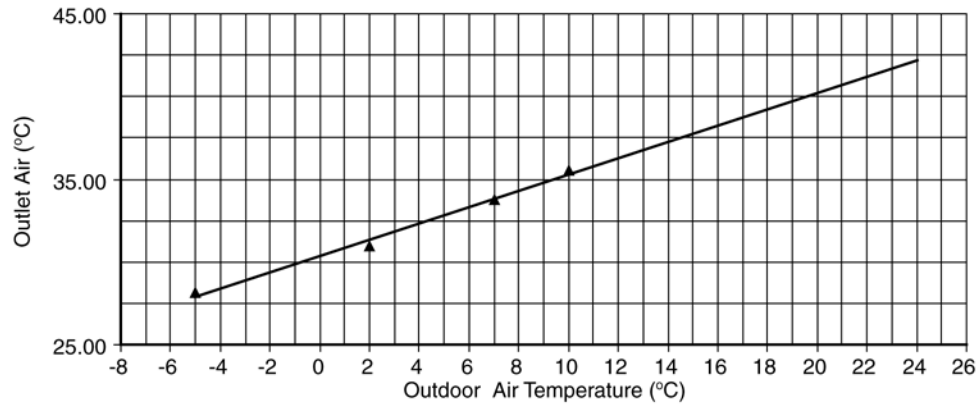

• Piping Length Characteristic

[Condition] Indoor temperature: 20/-°C, 7/6°C
 Remote condition: High fan speed, Heat 30°C
 Comp. Hz: F_h
 Voltage: 230V

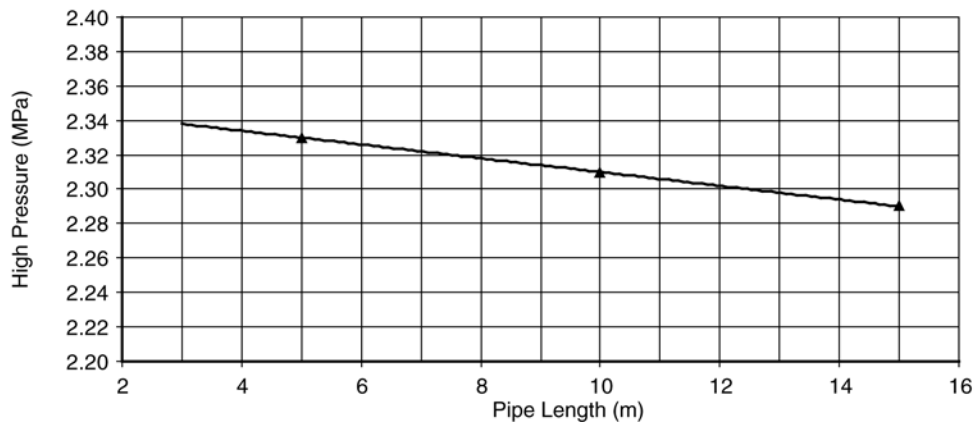
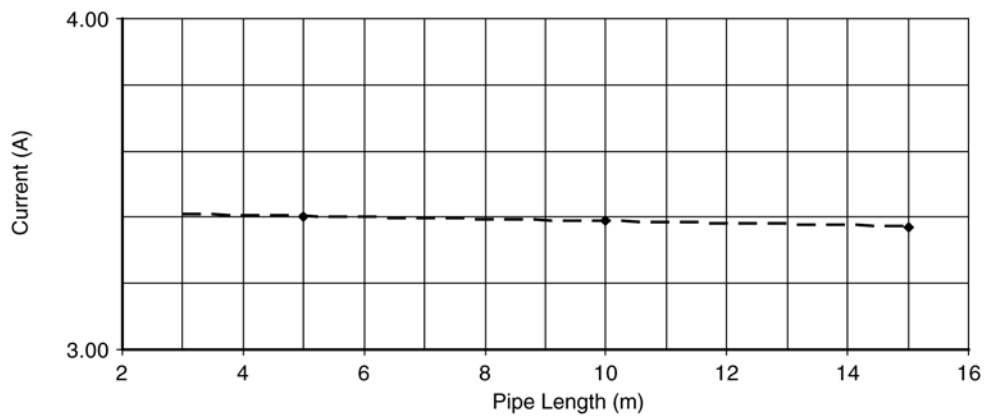
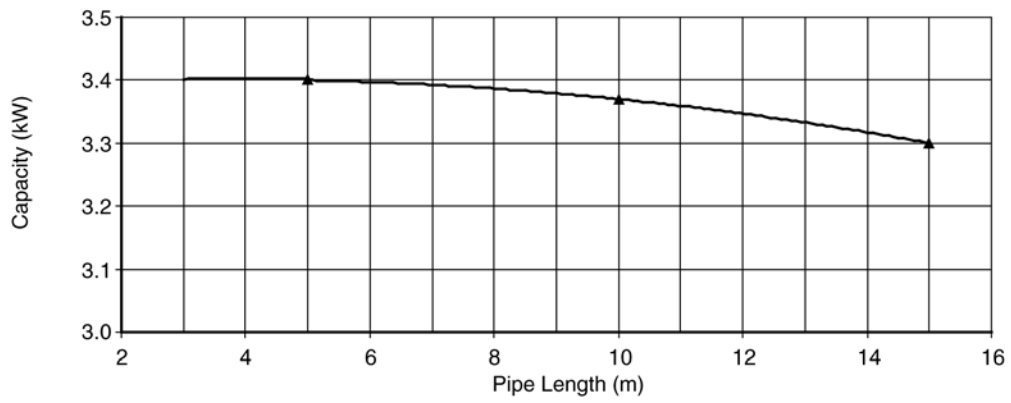
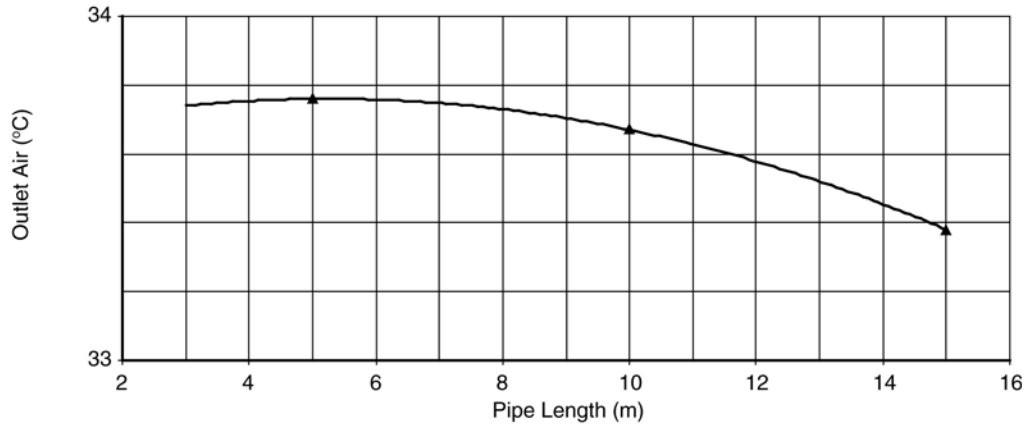

17.1.3. CU-E12JKE

• Cooling Characteristic

[Condition] Indoor temperature: 27/19°C
Remote condition: High fan speed, Cool 16°C
Comp. Hz: F_c
Voltage: 230V

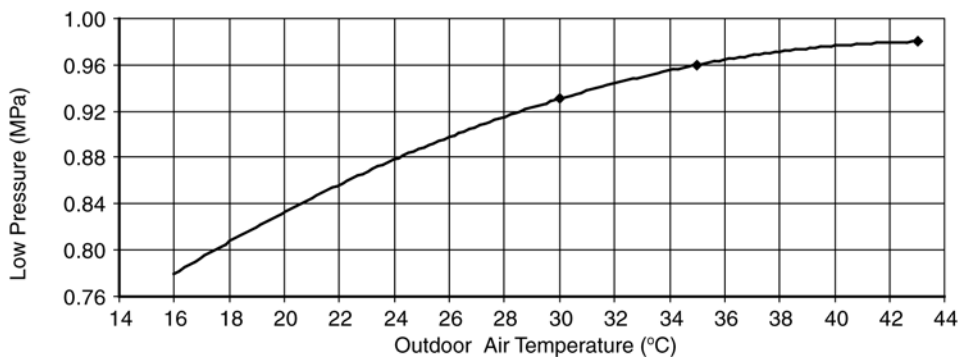
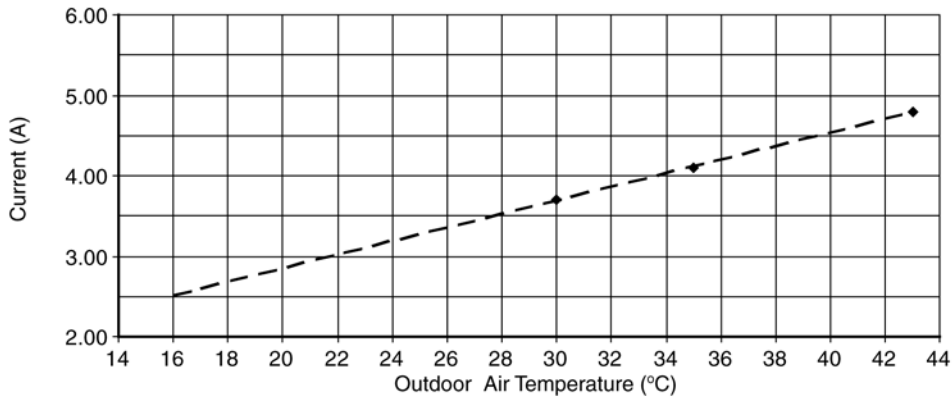
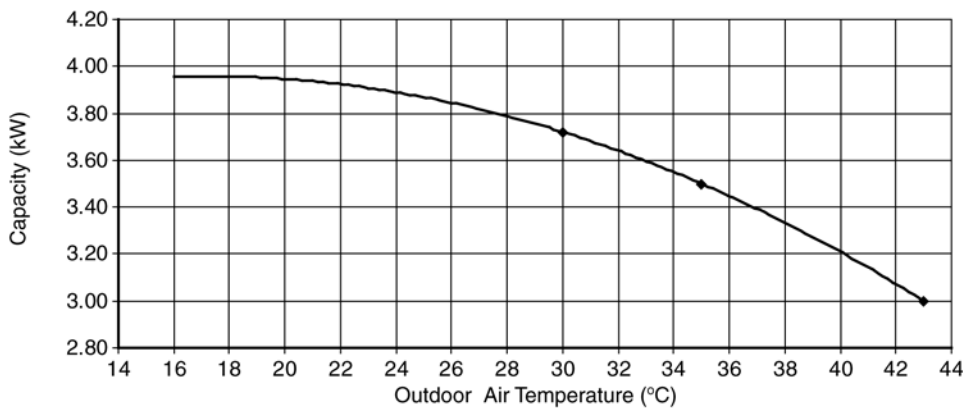
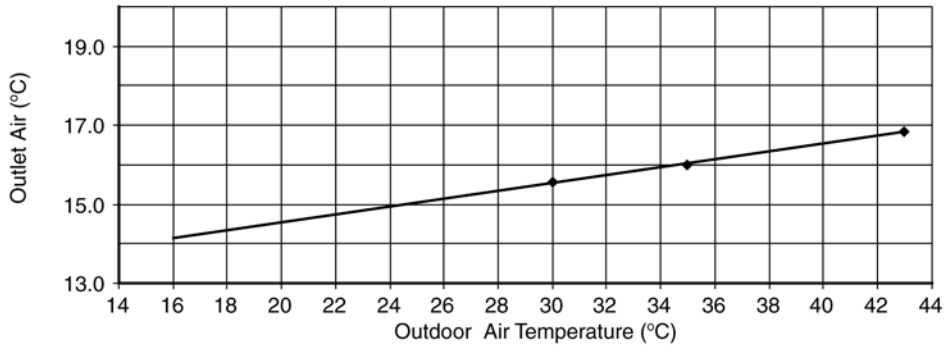

• Piping Length Characteristic

[Condition] Indoor temperature: 27/19°C, 35/-°C
 Remote condition: High fan speed, Cool 16°C
 Comp. Hz: F_c
 Voltage: 230V

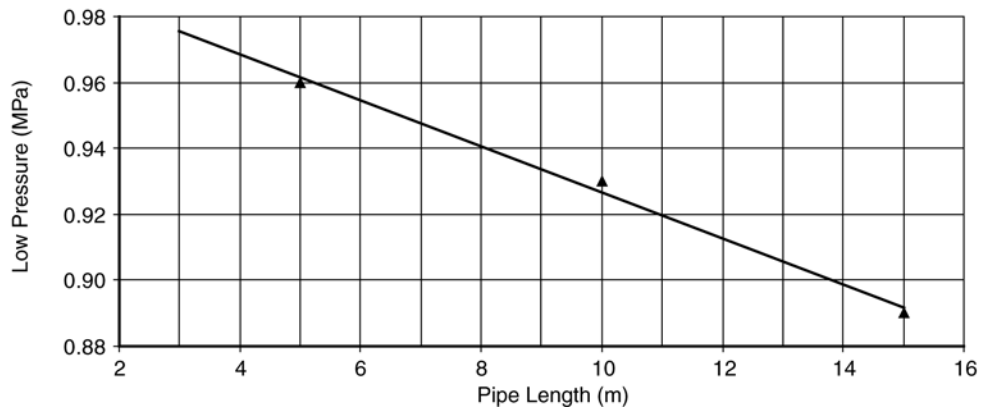
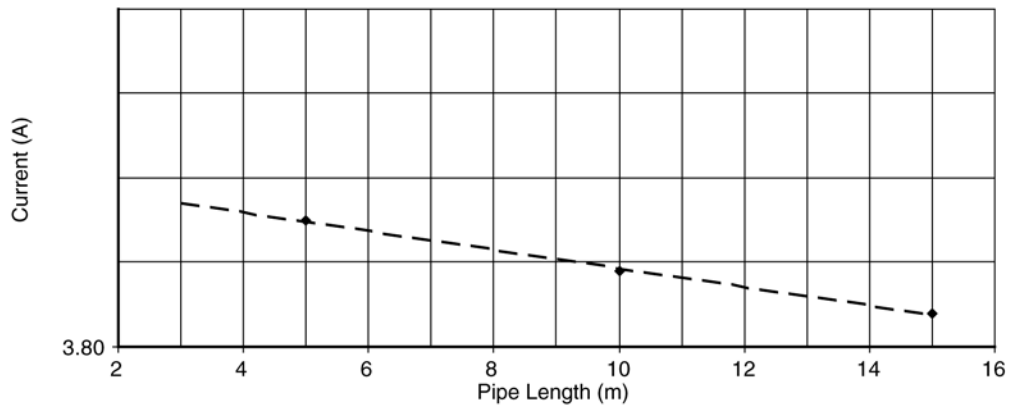
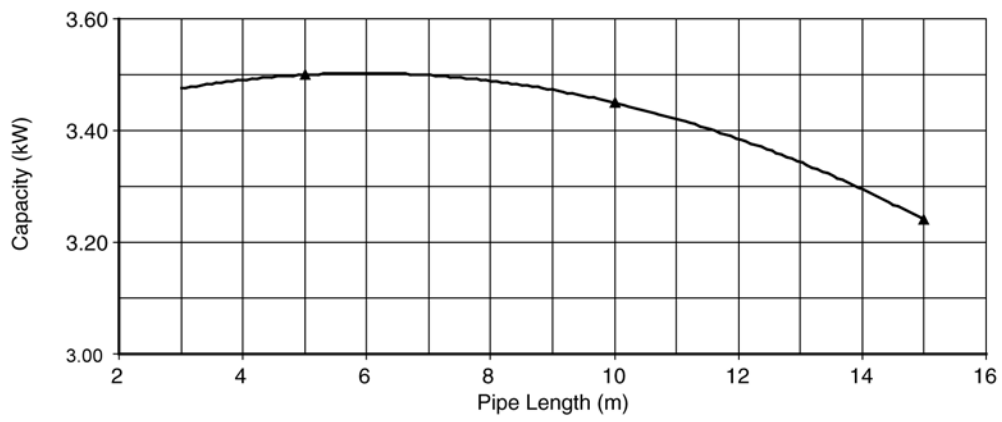
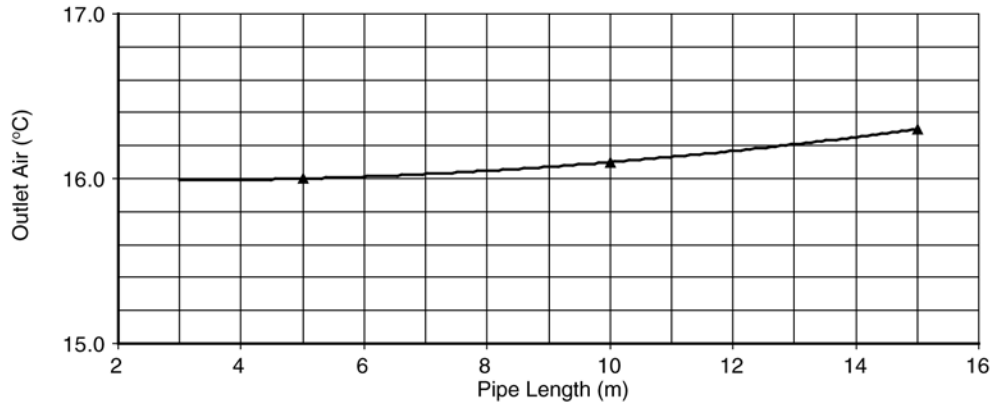

• Heating Characteristic

[Condition] Indoor temperature: 20/-°C

Remote condition: High fan speed, Heat 30°C

Comp. Hz: F_h

Voltage: 230V

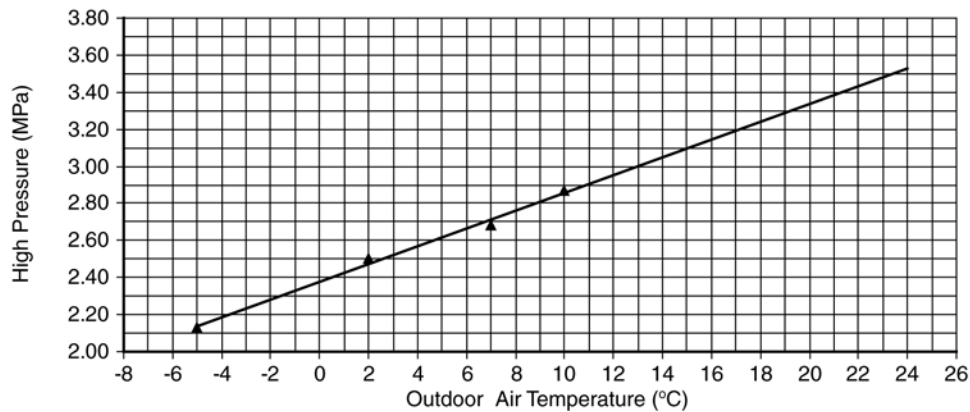
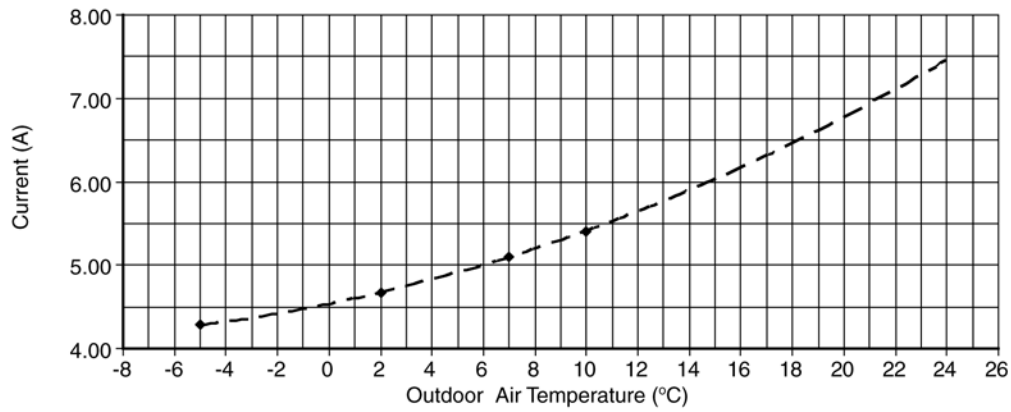
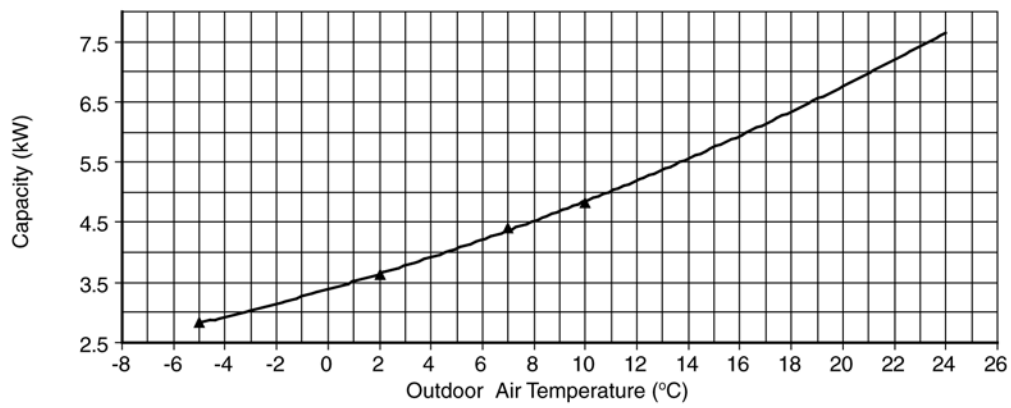
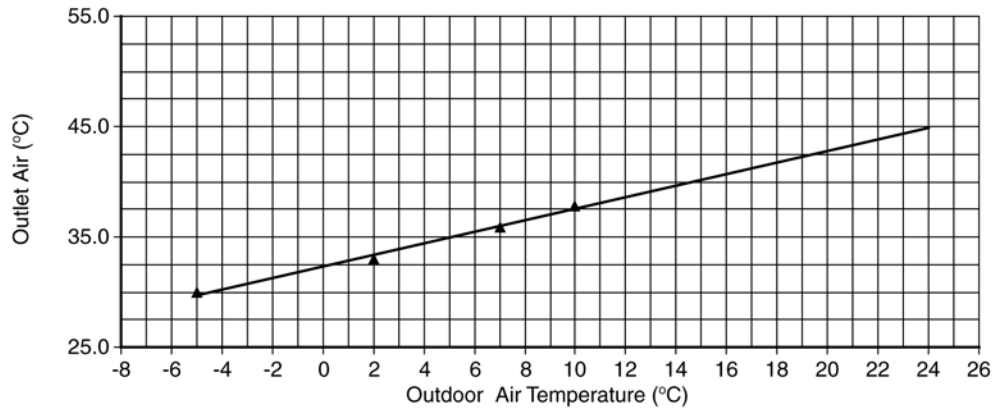

• Piping Length Characteristic

[Condition] Indoor temperature: 20/-°C, 7/6°C
 Remote condition: High fan speed, Heat 30°C
 Comp. Hz: F_h
 Voltage: 230V

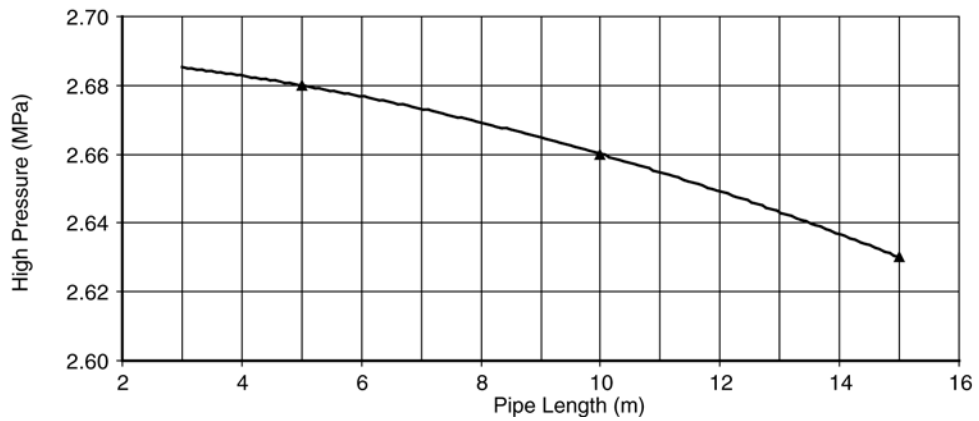
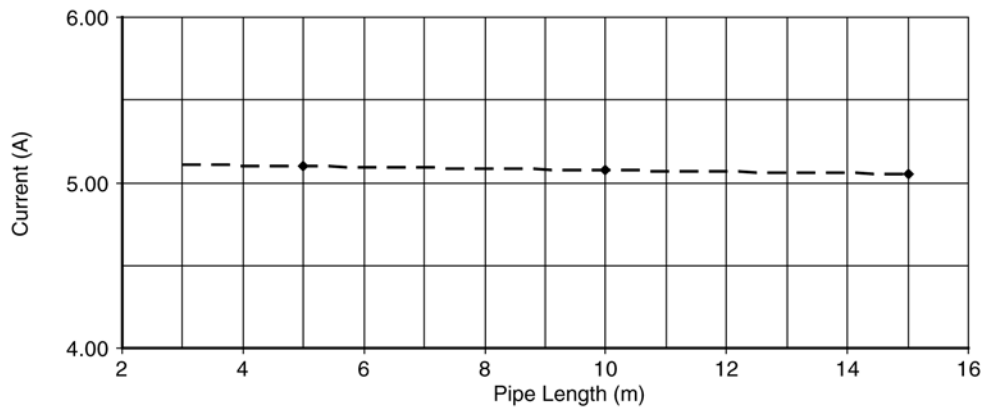
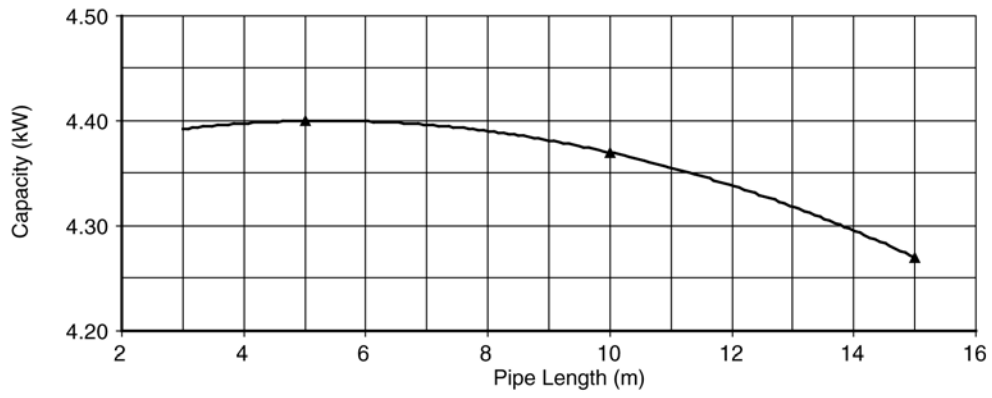
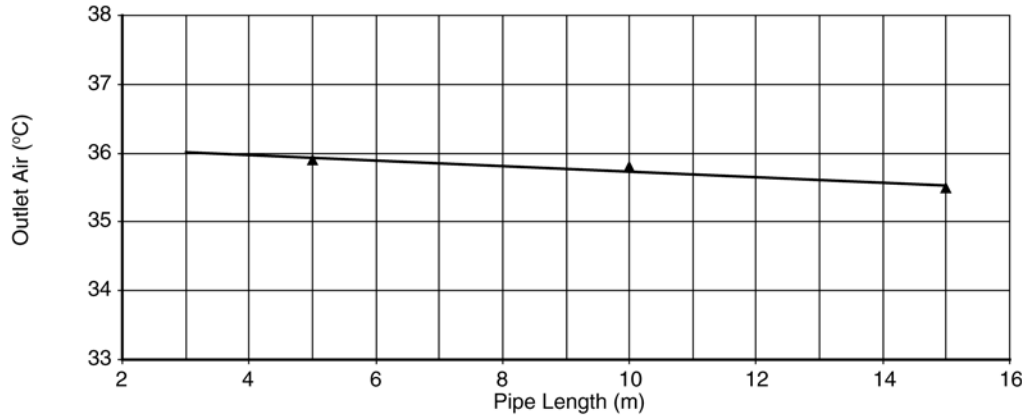

17.1.4. CU-E15JKE

• Cooling Characteristic

[Condition] Indoor temperature: 27/19°C
Remote condition: High fan speed, Cool 16°C
Comp. Hz: F_c
Voltage: 230V

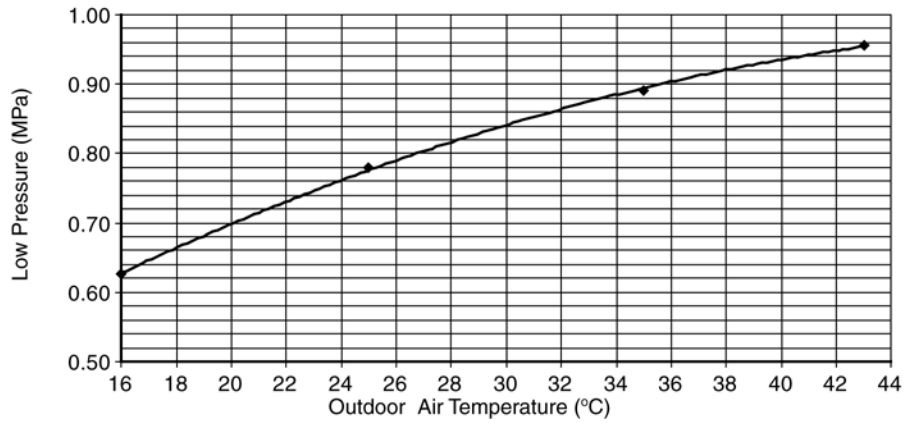
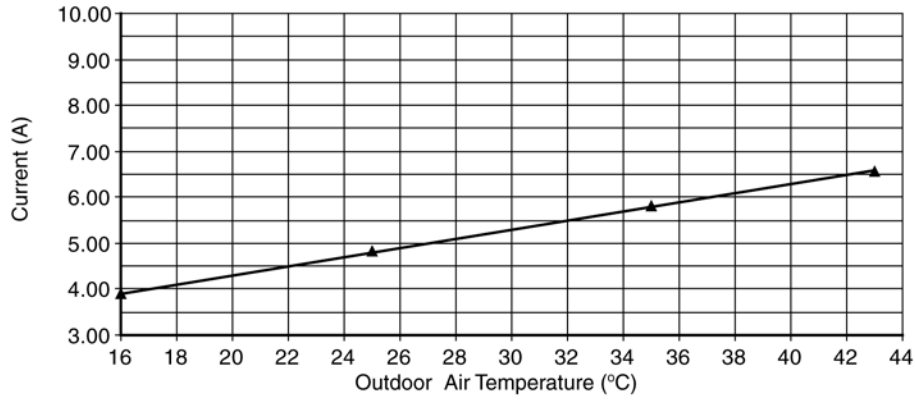
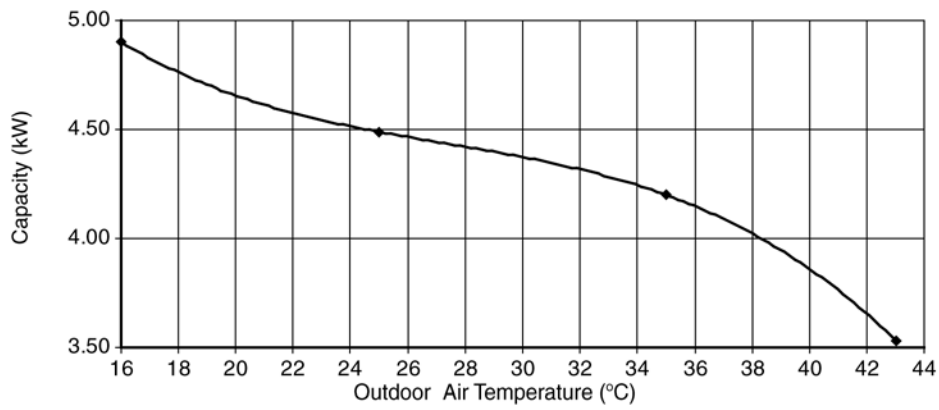
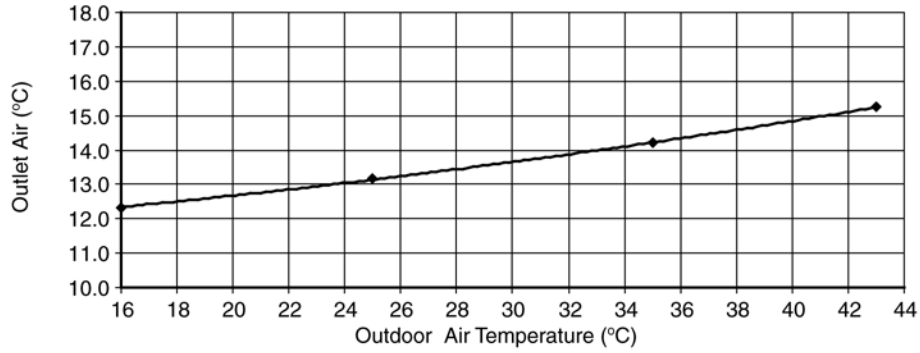

• Piping Length Characteristic (Cooling)

[Condition] Indoor temperature: 27/19°C, 35/-°C
 Remote condition: High fan speed, Cool 16°C
 Comp. Hz: F_c
 Voltage: 230V

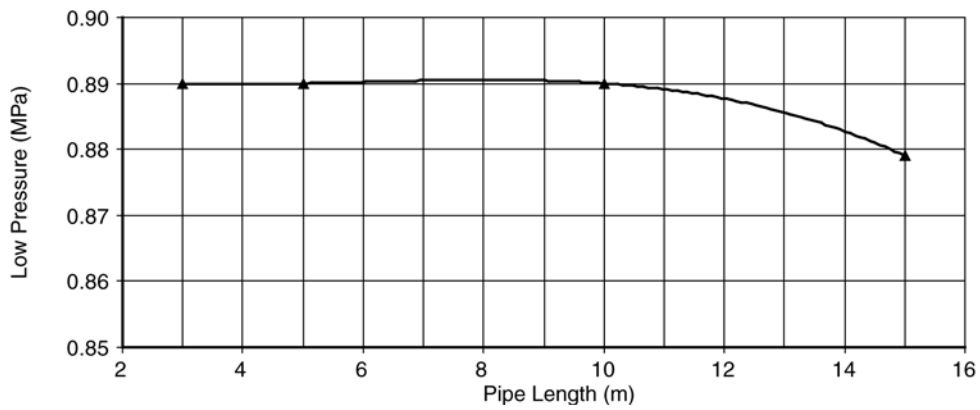
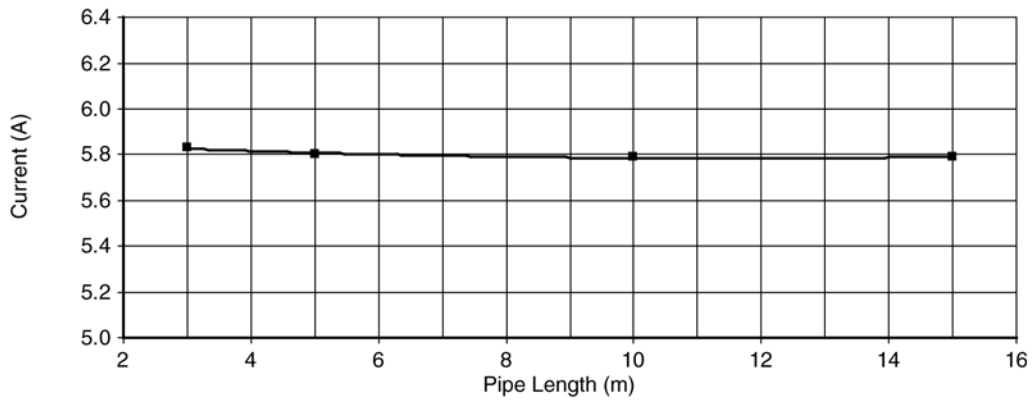
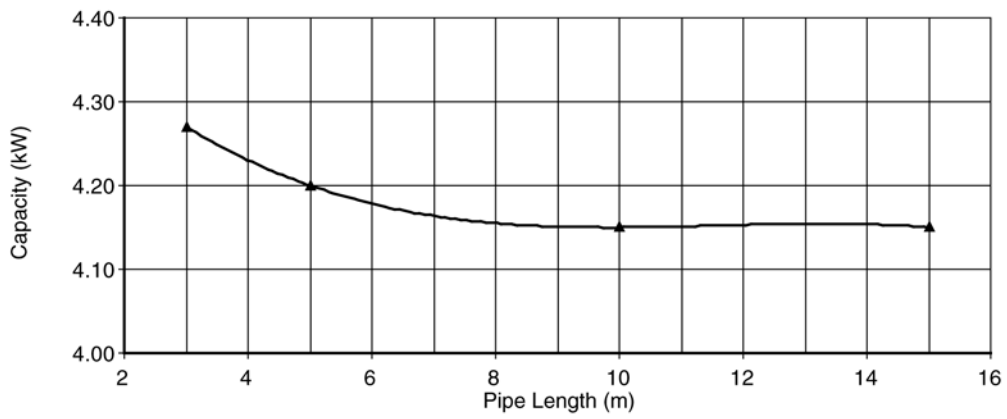
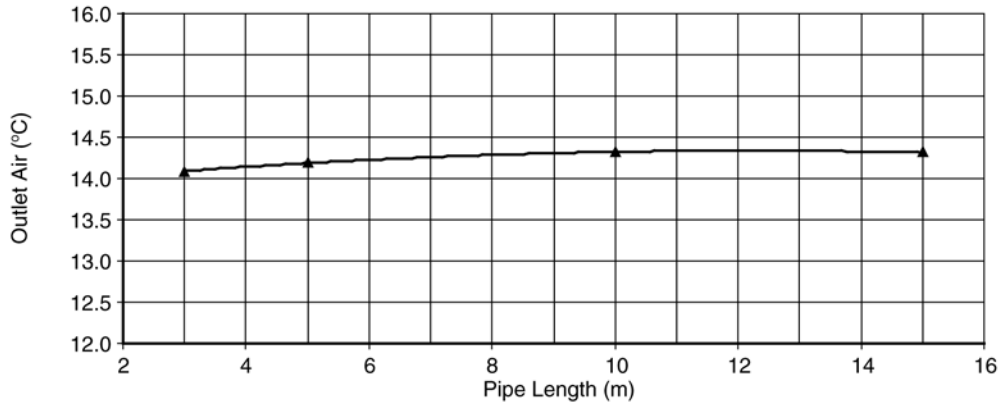

• Heating Characteristic

[Condition] Indoor temperature: 20/-°C

Remote condition: High fan speed, Heat 30°C

Comp. Hz: F_h

Voltage: 230V

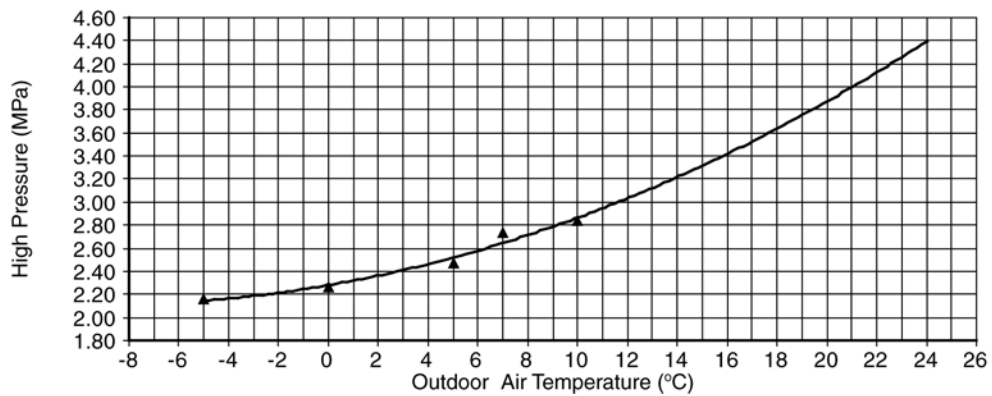
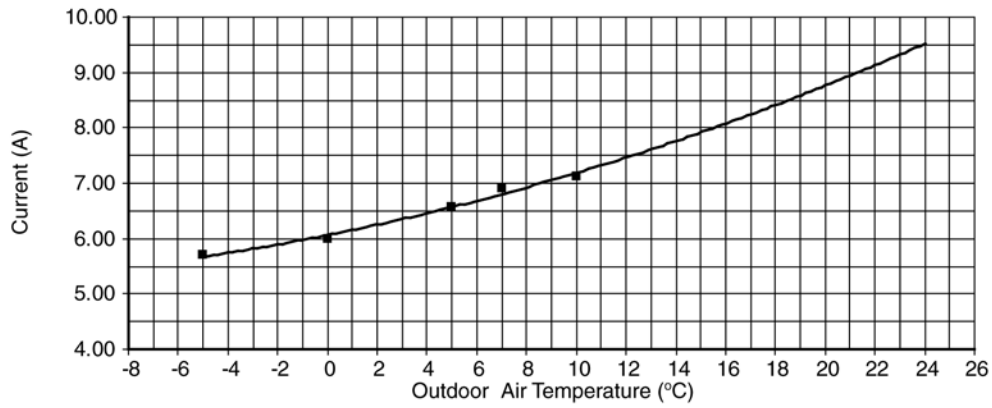
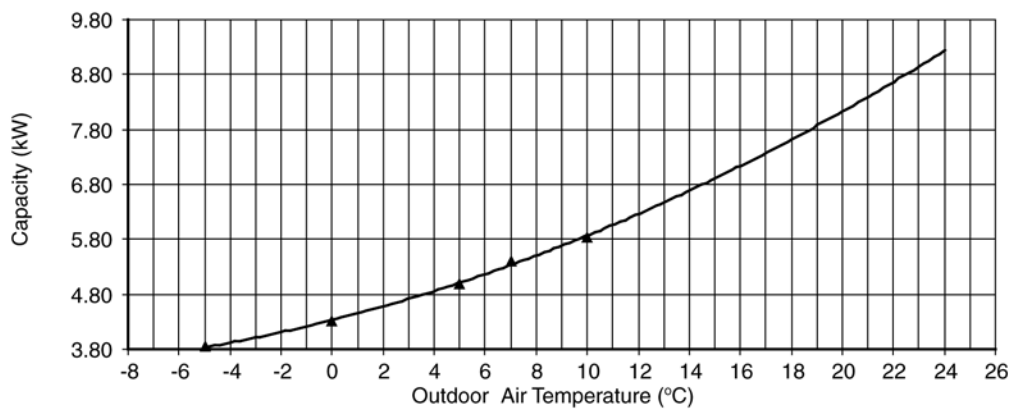
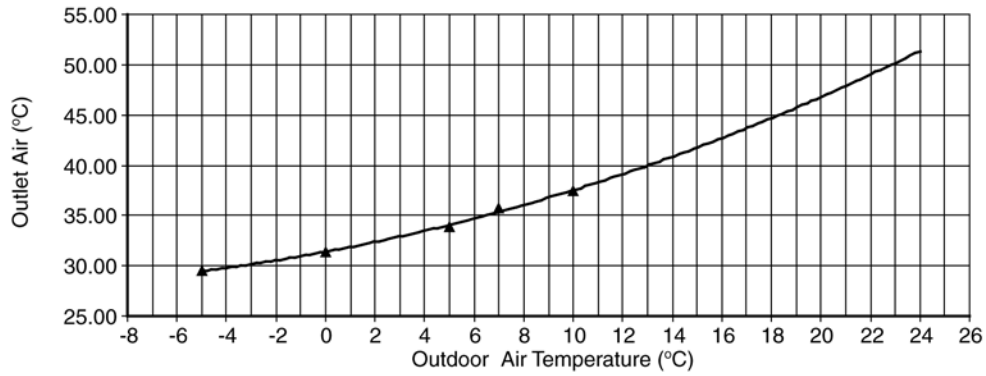

• Piping Length Characteristic (Heating)

[Condition] Indoor temperature: 20/-°C, 7/6°C
 Remote condition: High fan speed, Heat 30°C
 Comp. Hz: F_h
 Voltage: 230V

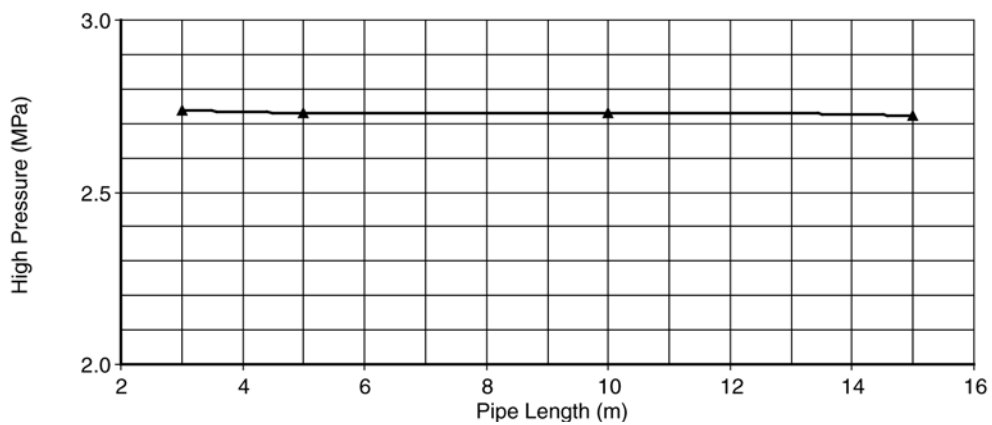
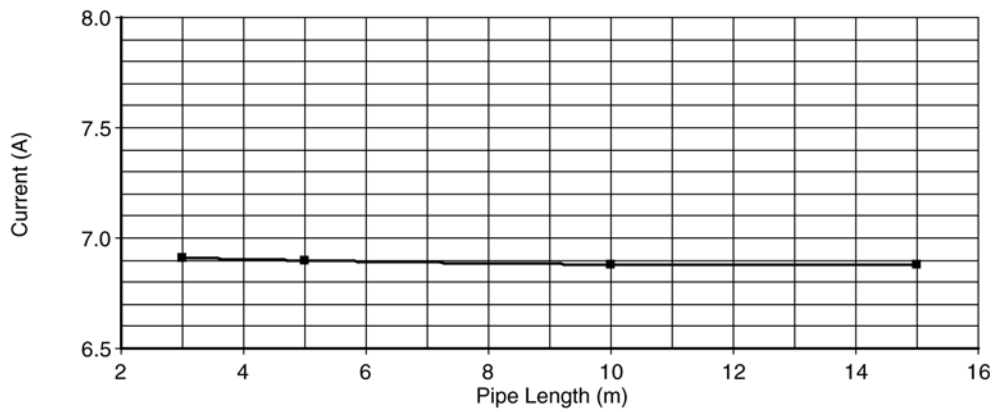
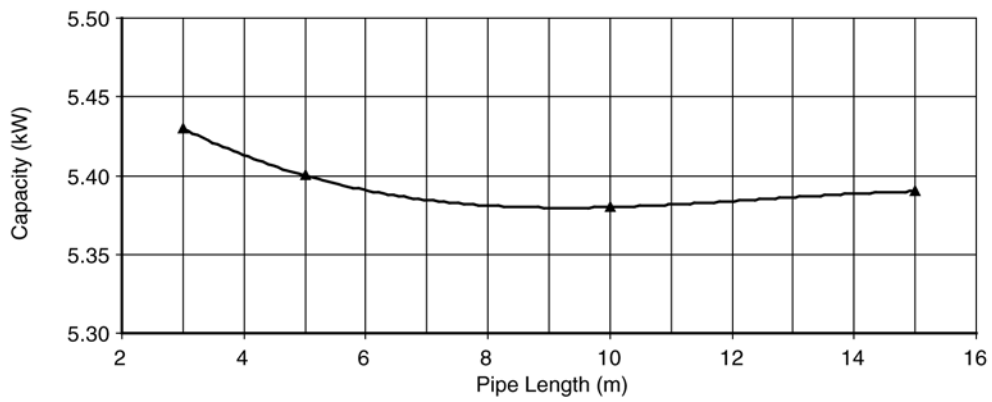
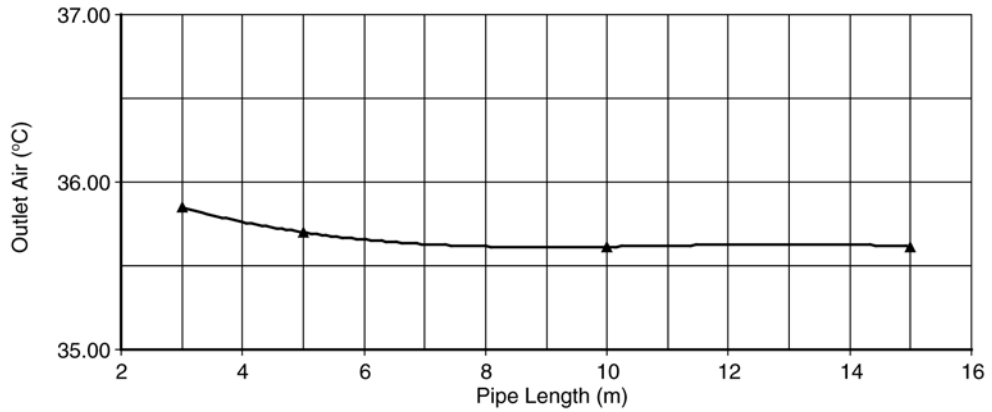

17.1.5. CU-E15JKE-1

• Cooling Characteristic

[Condition] Indoor temperature: 27/19°C
Remote condition: High fan speed, Cool 16°C
Comp. Hz: F_c
Voltage: 230V

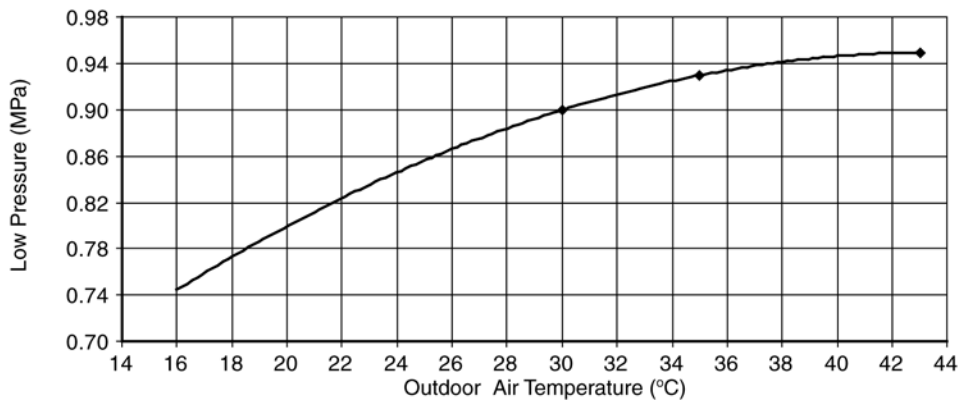
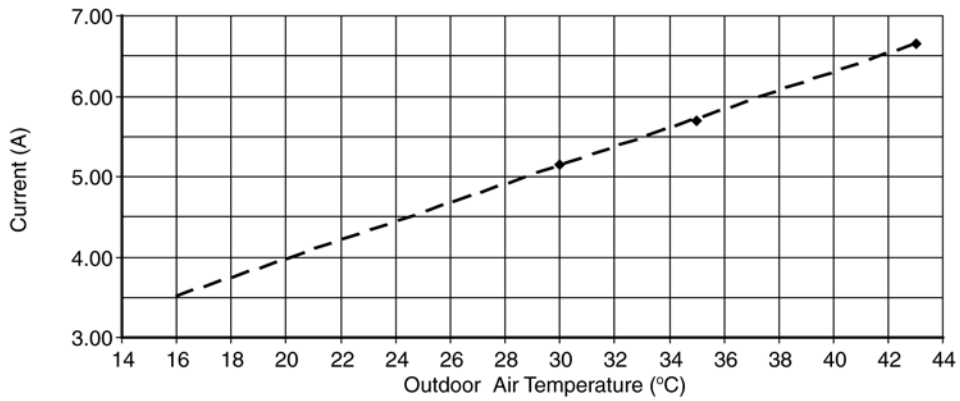
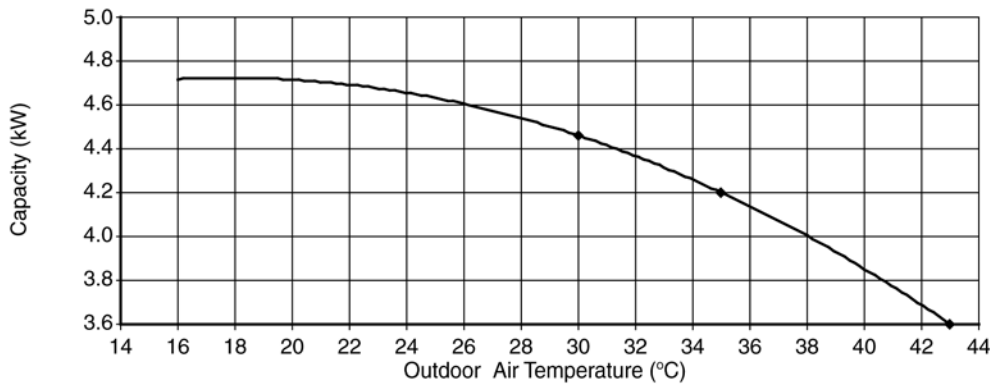
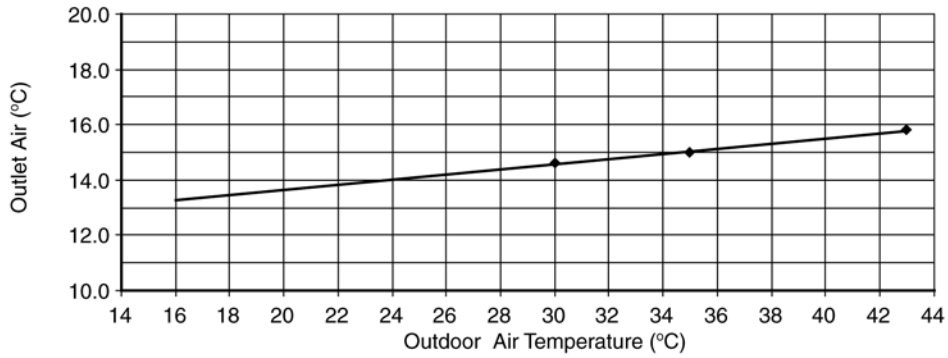

• Piping Length Characteristic (Cooling)

[Condition] Indoor temperature: 27/19°C, 35/-°C
 Remote condition: High fan speed, Cool 16°C
 Comp. Hz: F_c
 Voltage: 230V

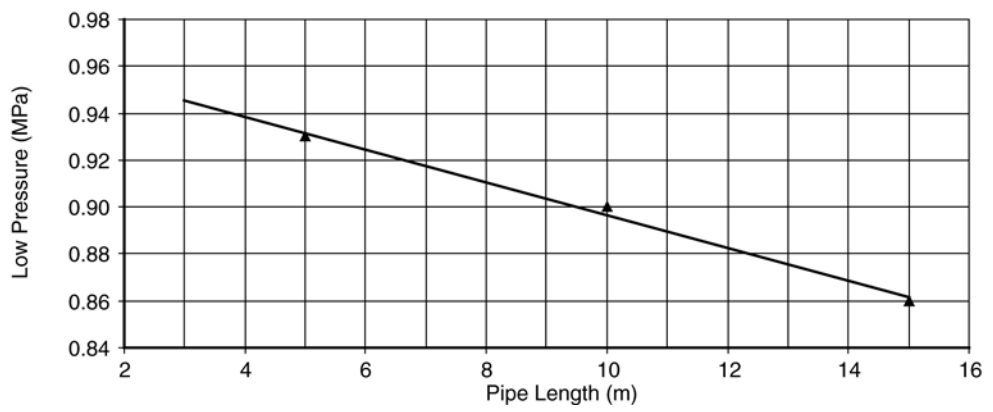
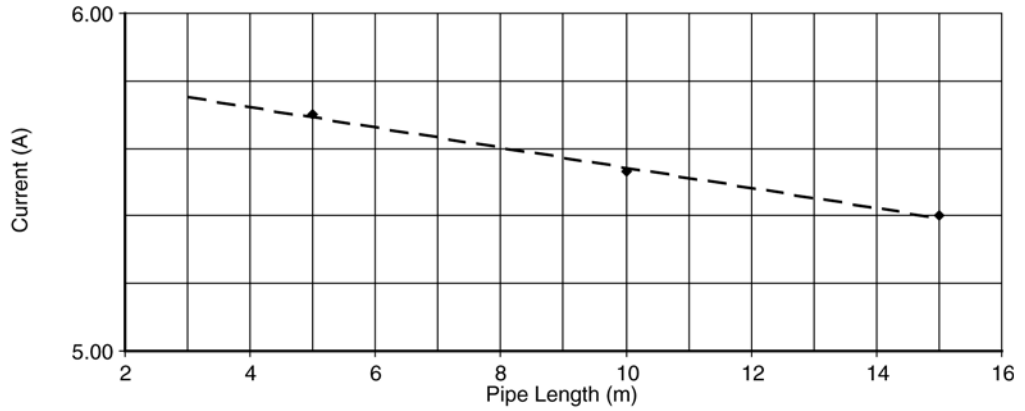
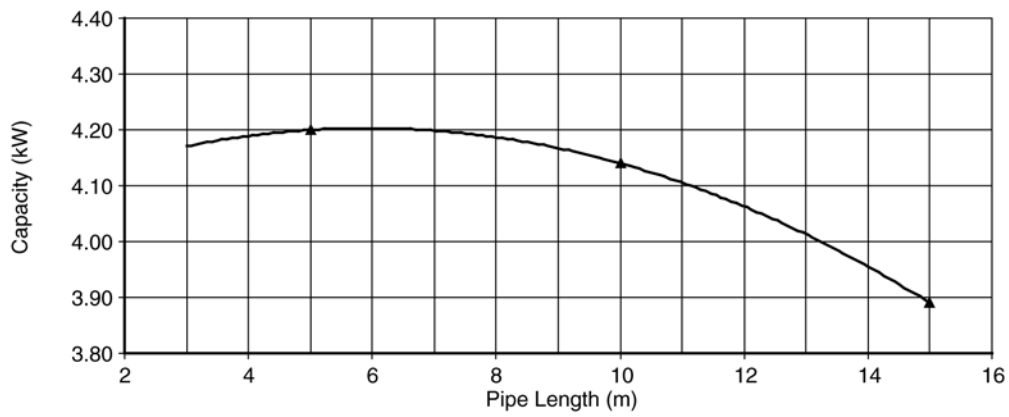
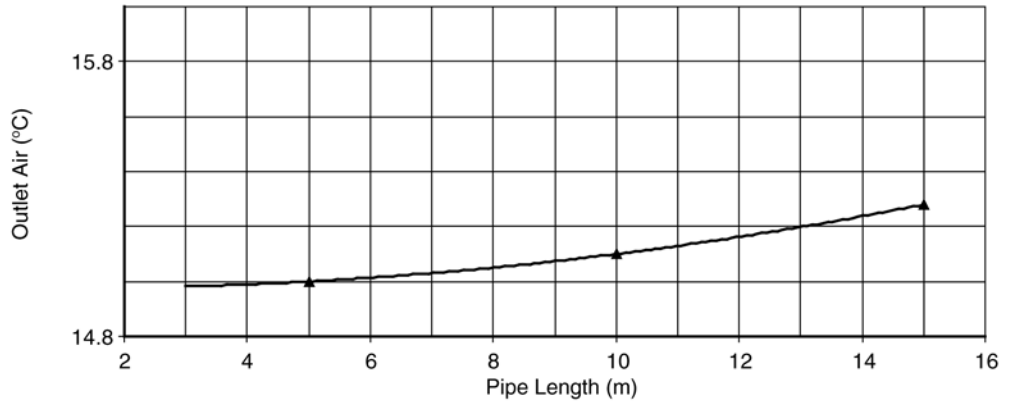

• Heating Characteristic

[Condition] Indoor temperature: 20/-°C

Remote condition: High fan speed, Heat 30°C

Comp. Hz: F_h

Voltage: 230V

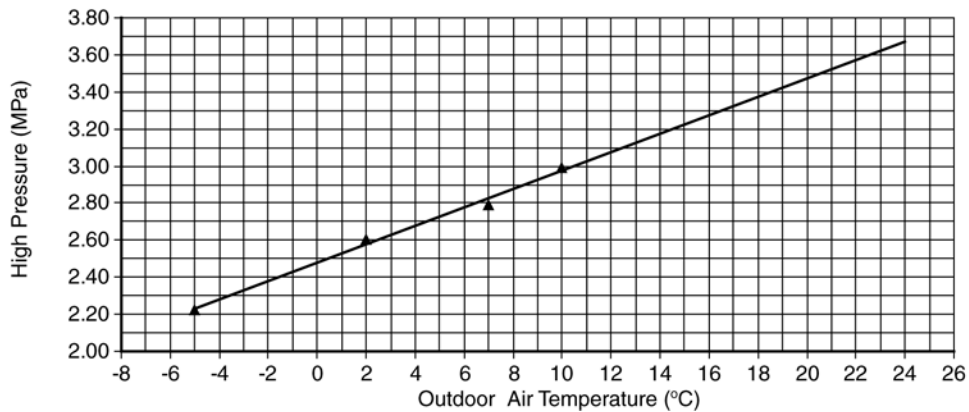
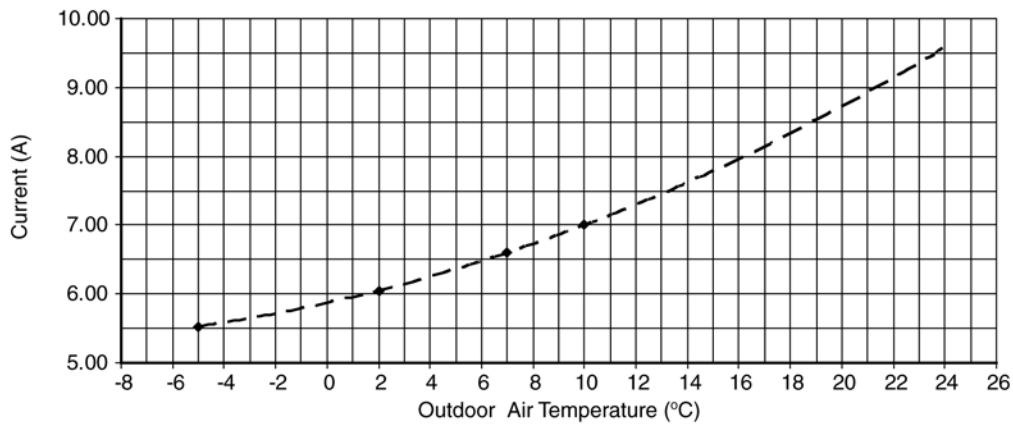
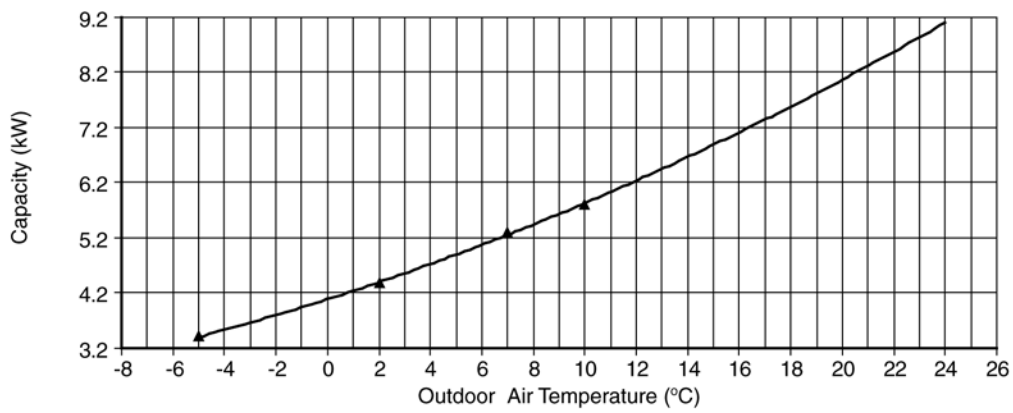
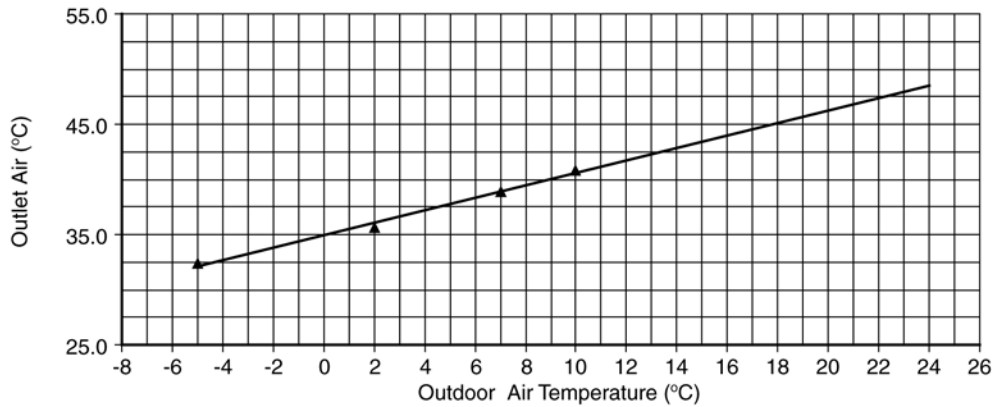

• Piping Length Characteristic (Heating)

[Condition] Indoor temperature: 20/-°C, 7/6°C
 Remote condition: High fan speed, Heat 30°C
 Comp. Hz: F_h
 Voltage: 230V

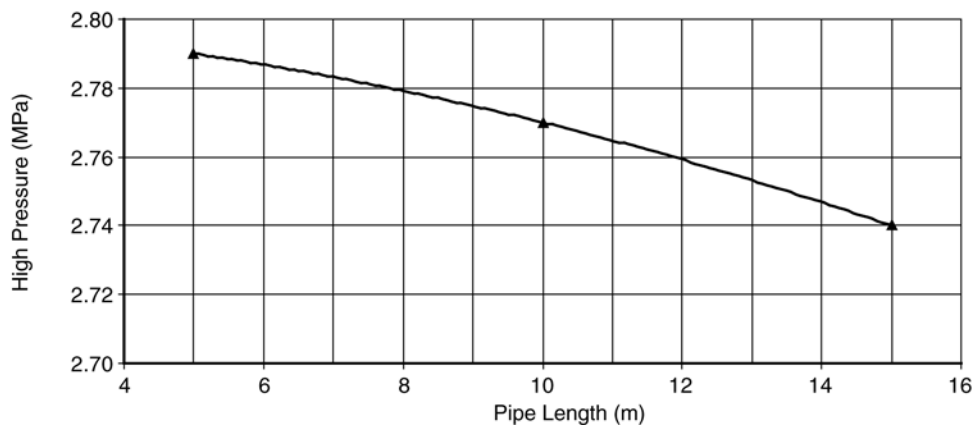
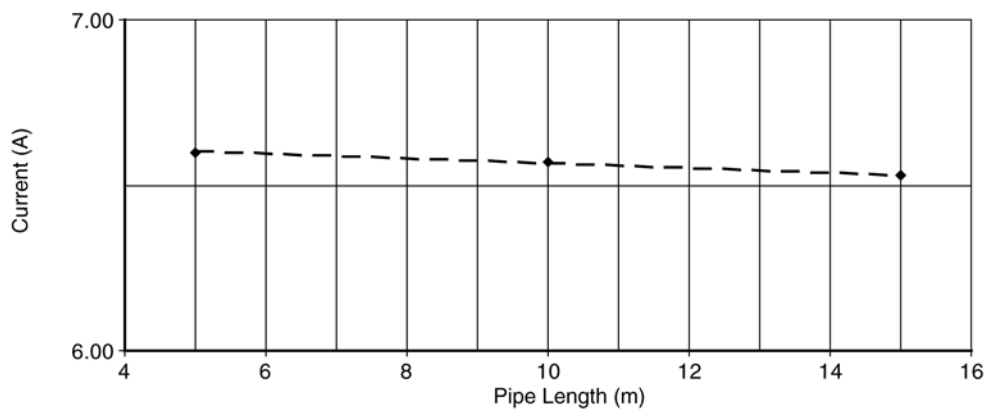
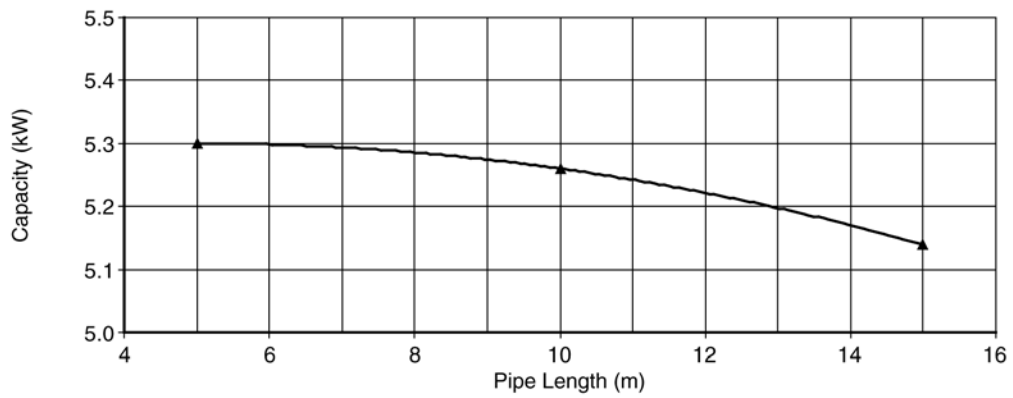
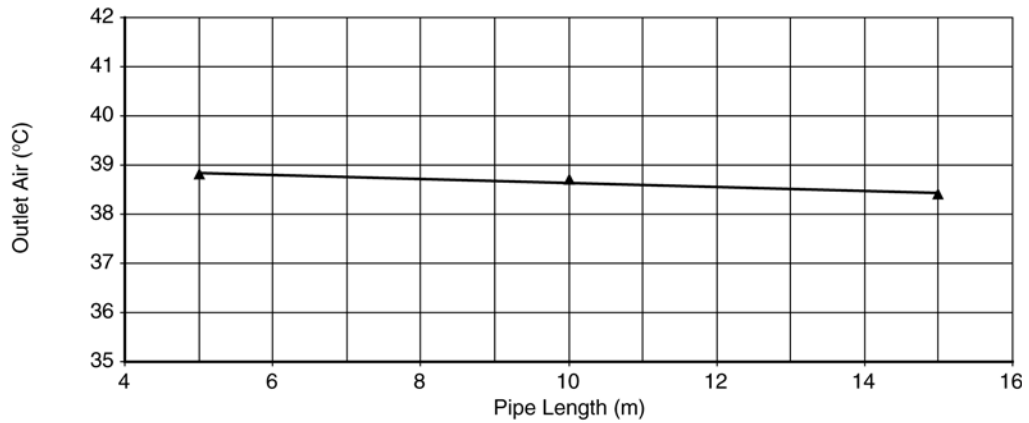

17.1.6. CU-E7JKE-3

• Cooling Characteristic

[Condition] Indoor temperature: 27/19°C
Remote condition: High fan speed, Cool 16°C
Comp. Hz: F_c
Voltage: 230V

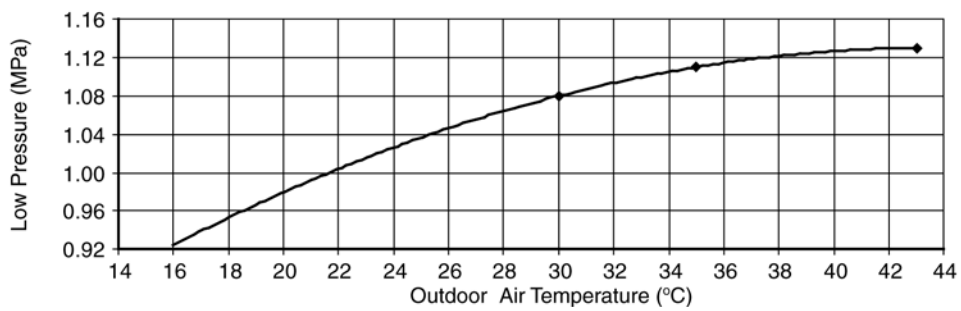
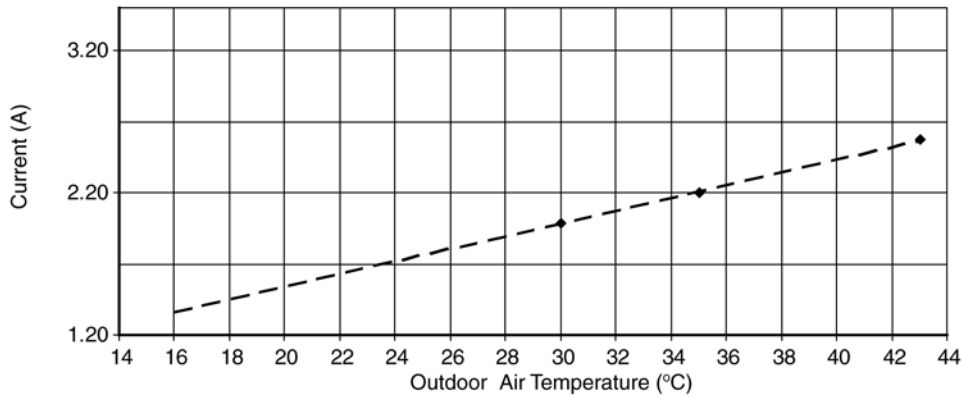
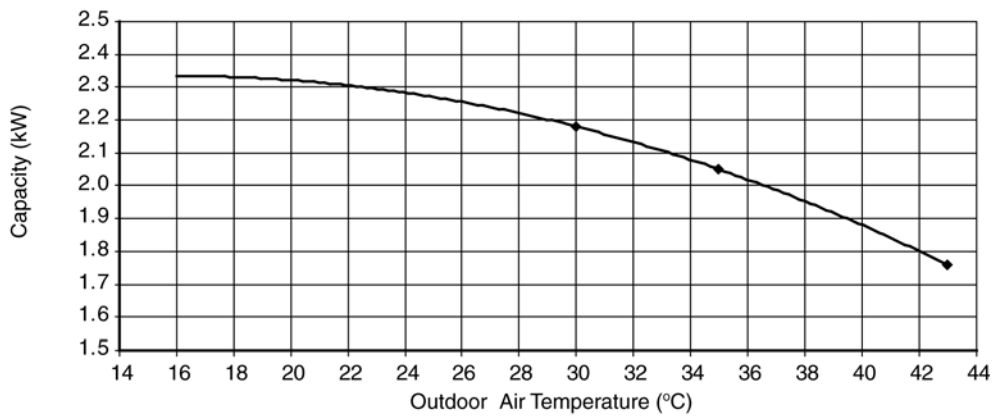
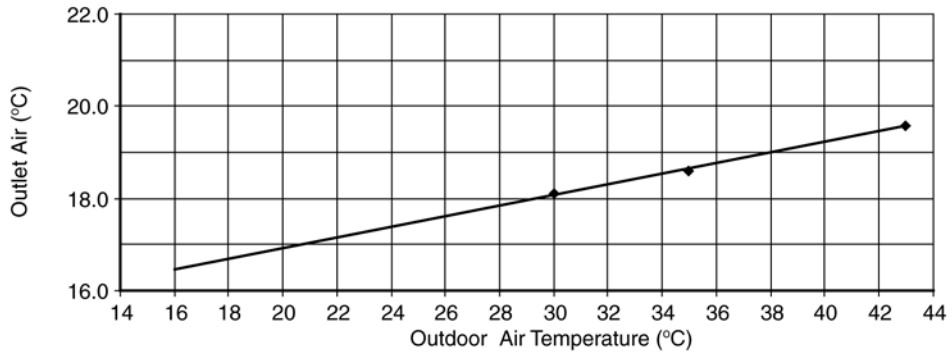

• Piping Length Characteristic

[Condition] Indoor temperature: 27/19°C, 35/-°C
 Remote condition: High fan speed, Cool 16°C
 Comp. Hz: F_c
 Voltage: 230V

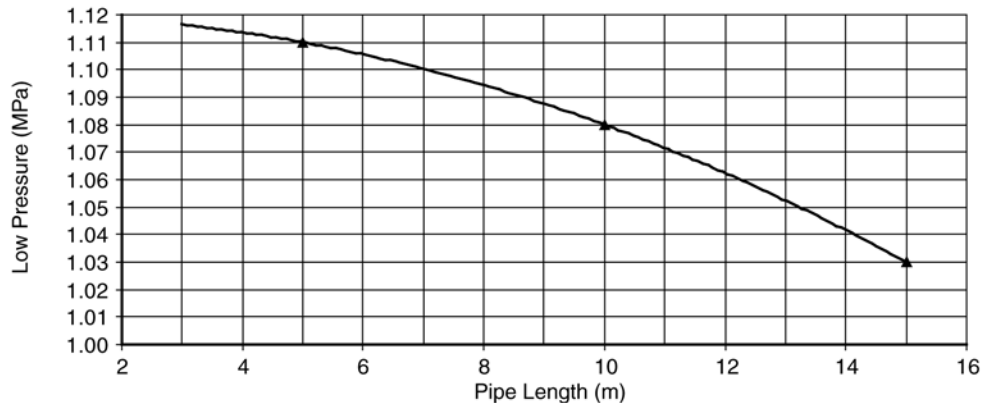
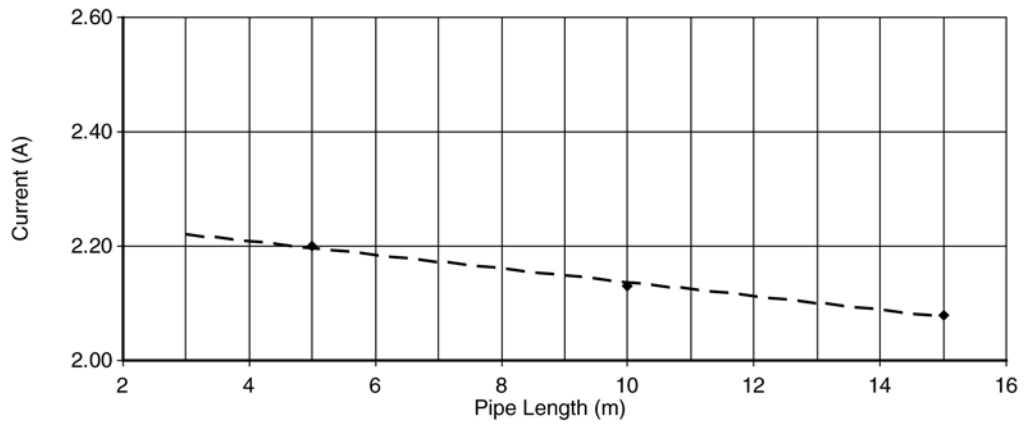
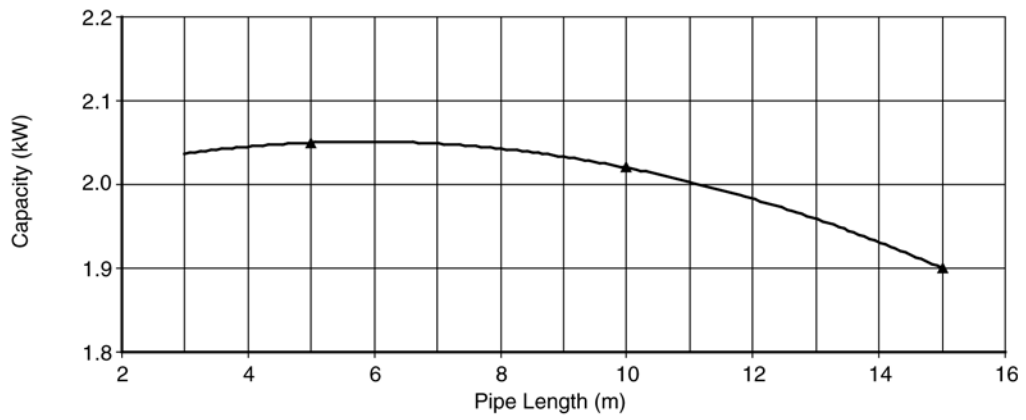
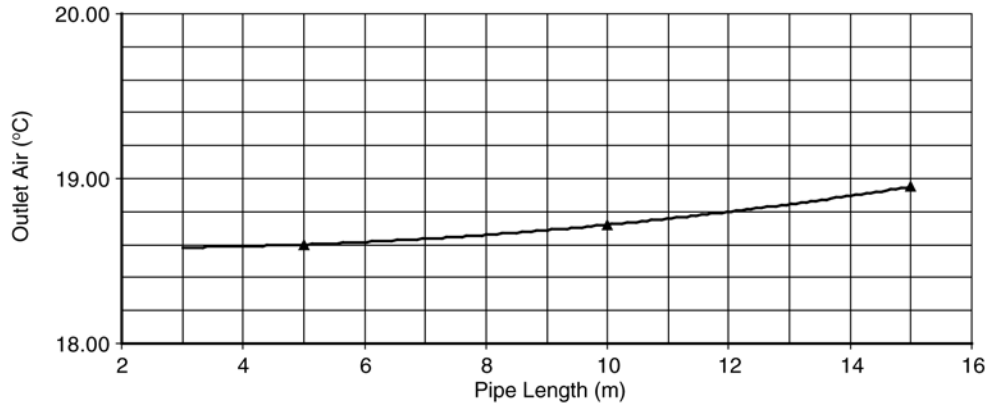

• Heating Characteristic

[Condition] Indoor temperature: 20/-°C

Remote condition: High fan speed, Heat 30°C

Comp. Hz: F_h

Voltage: 230V

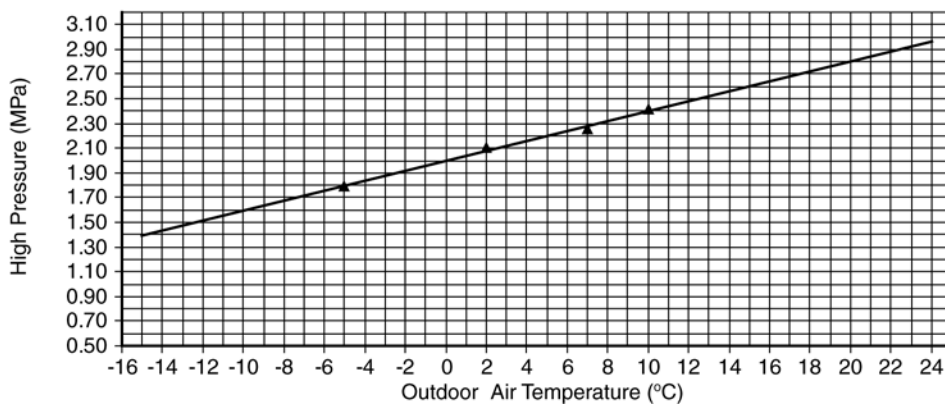
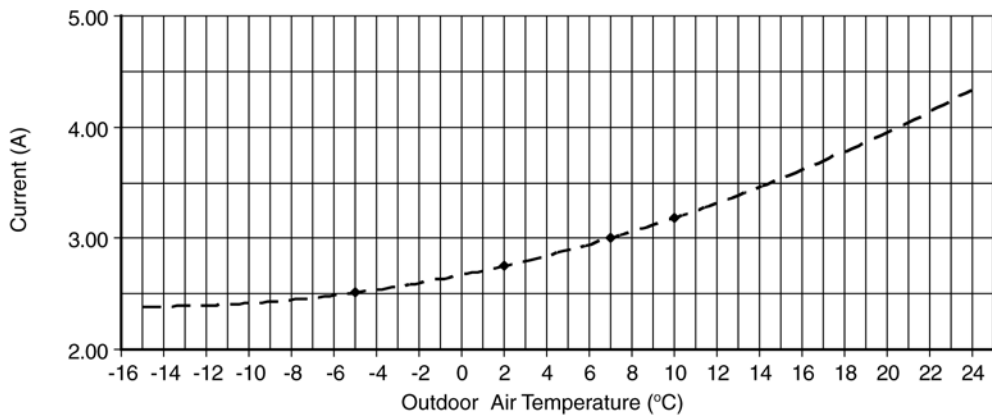
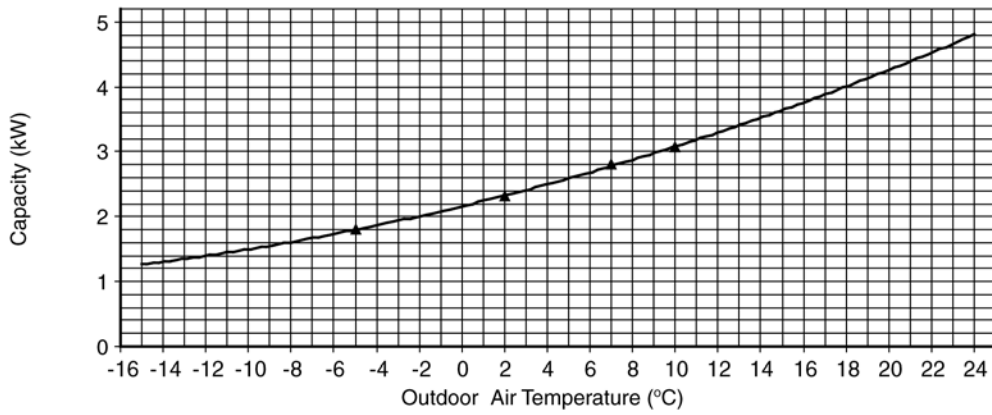
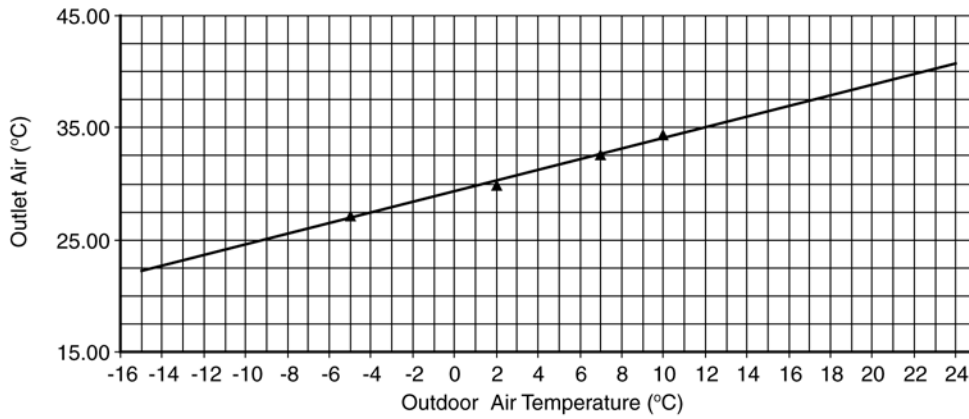

• Piping Length Characteristic

[Condition] Indoor temperature: 20/-°C, 7/6°C
 Remote condition: High fan speed, Heat 30°C
 Comp. Hz: F_h
 Voltage: 230V

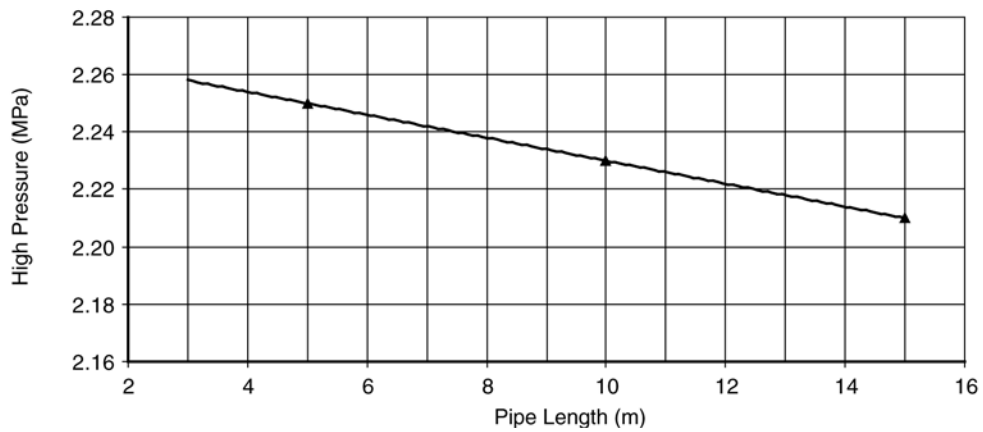
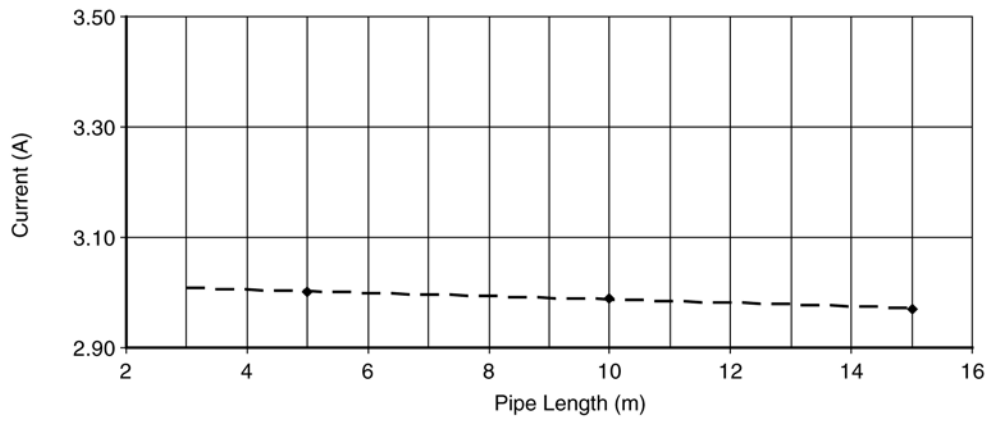
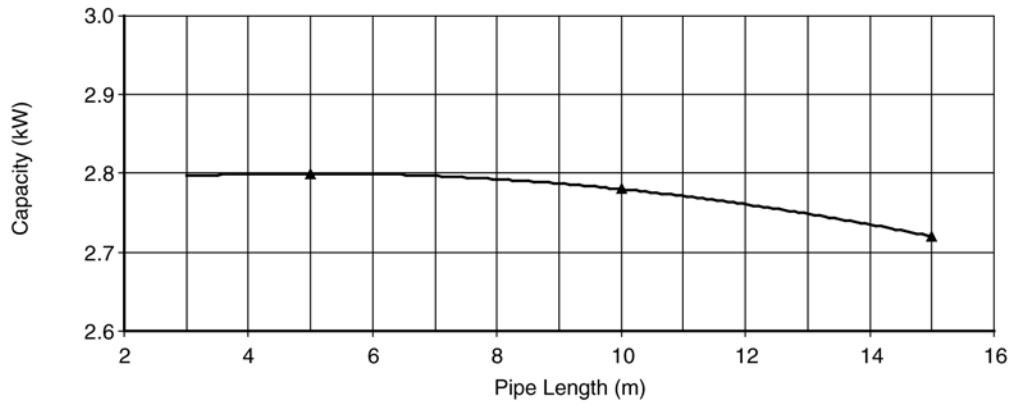
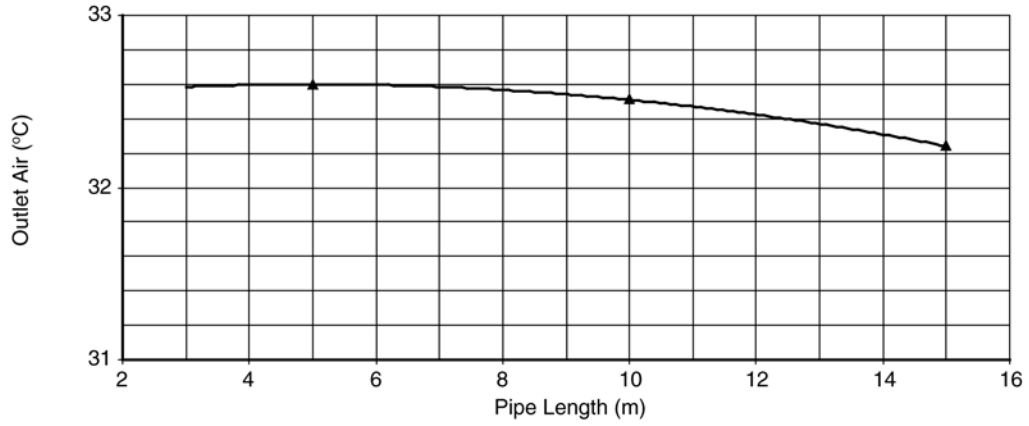

17.1.7. CU-E9JKE-3

• Cooling Characteristic

[Condition] Indoor temperature: 27/19°C
Remote condition: High fan speed, Cool 16°C
Comp. Hz: F_c
Voltage: 230V

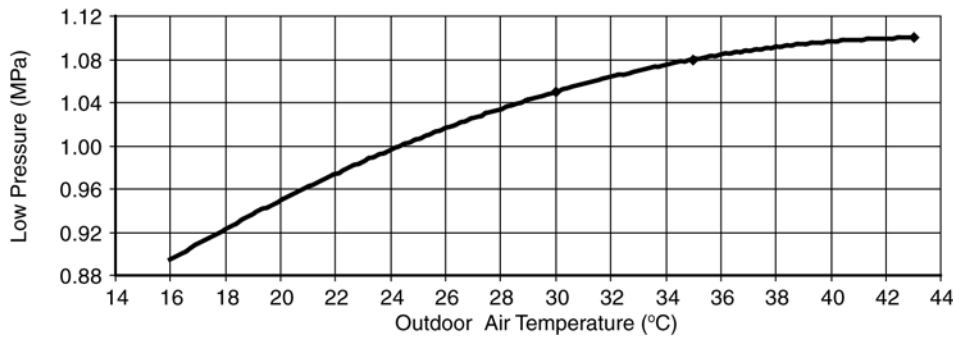
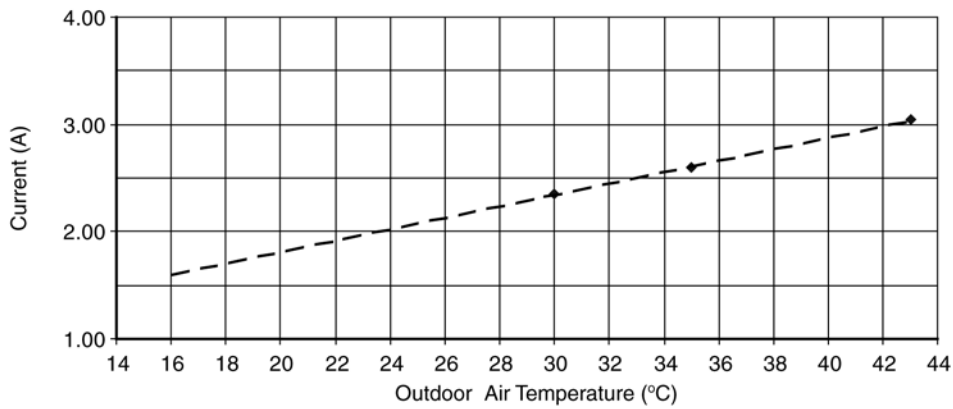
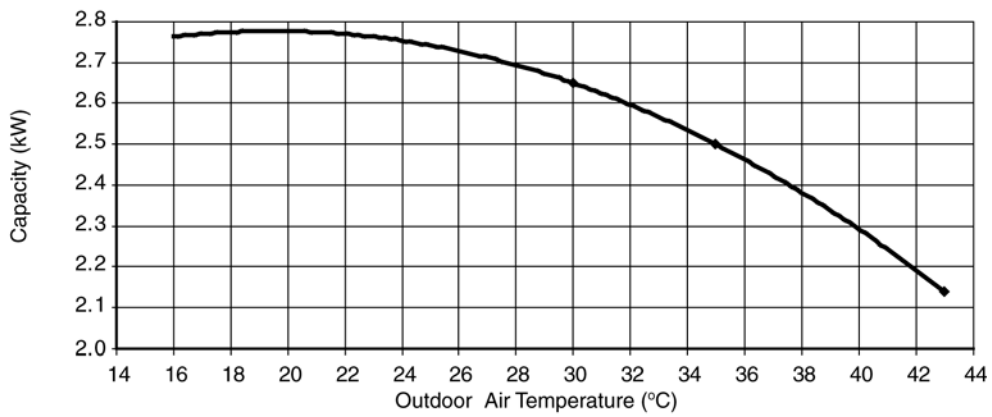
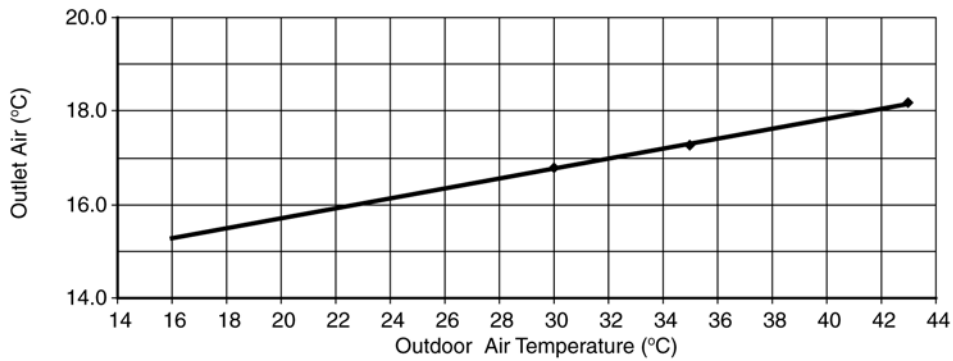

• Piping Length Characteristic

[Condition] Indoor temperature: 27/19°C, 35/-°C
 Remote condition: High fan speed, Cool 16°C
 Comp. Hz: F_c
 Voltage: 230V

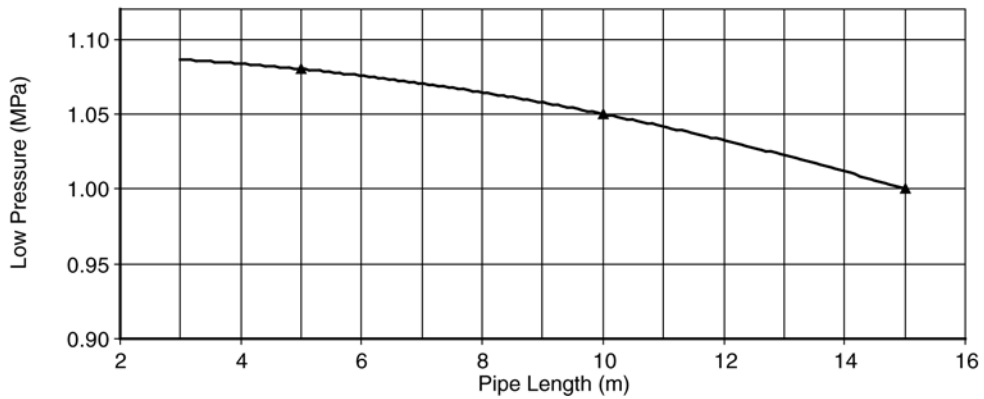
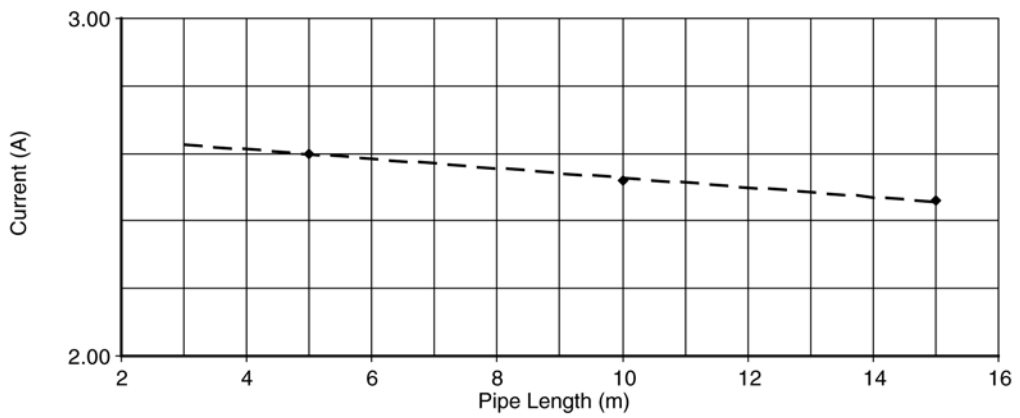
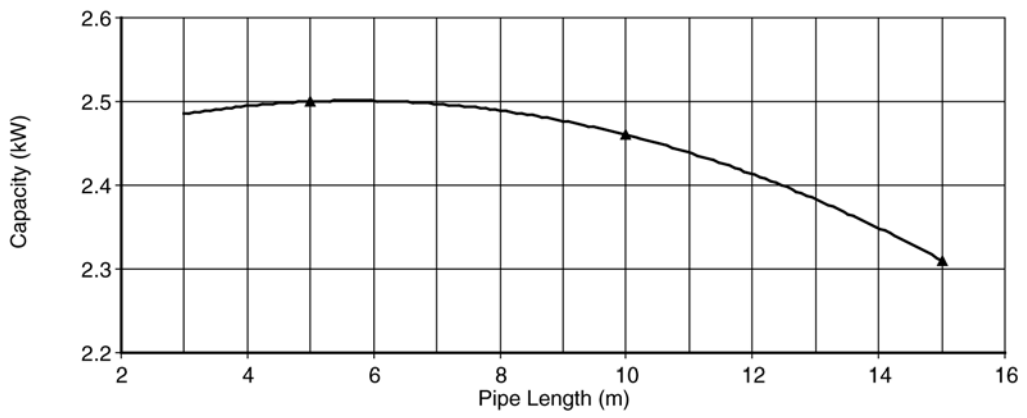
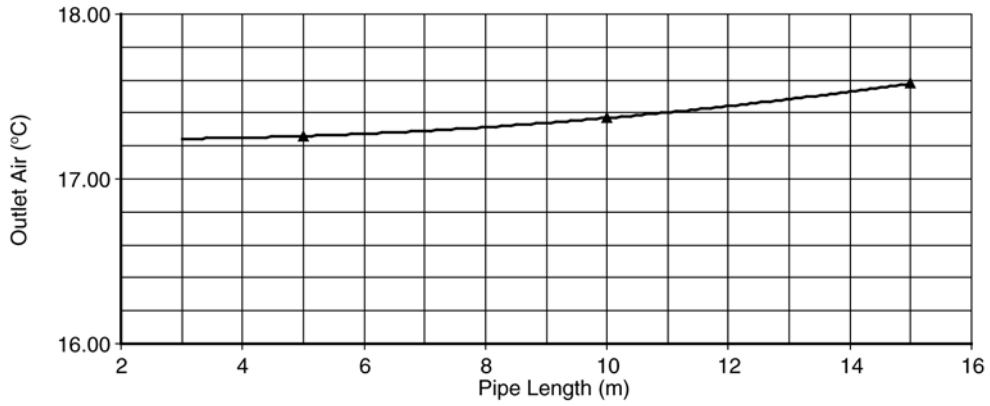

• Heating Characteristic

[Condition] Indoor temperature: 20/-°C

Remote condition: High fan speed, Heat 30°C

Comp. Hz: F_h

Voltage: 230V

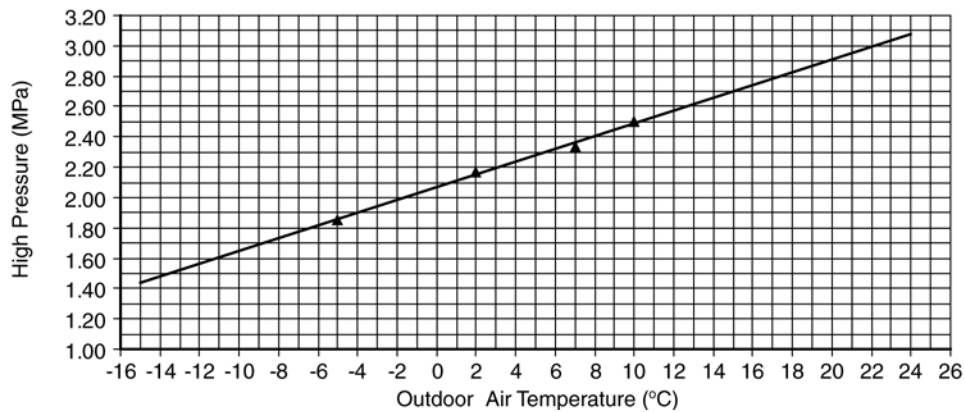
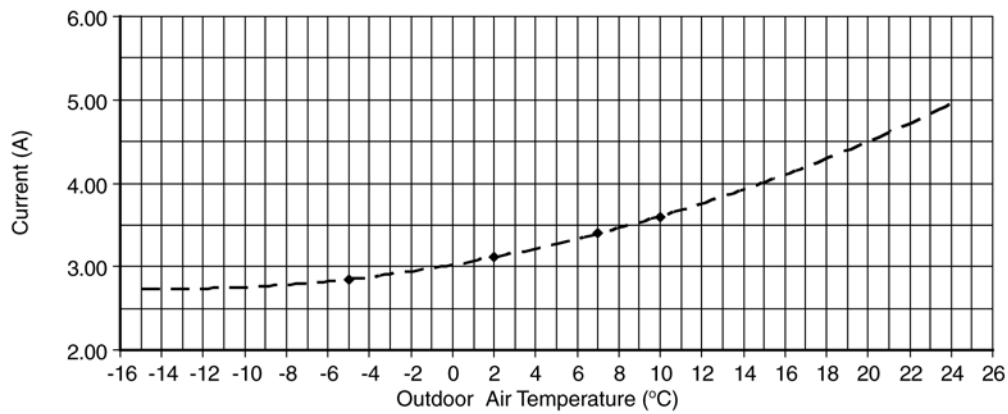
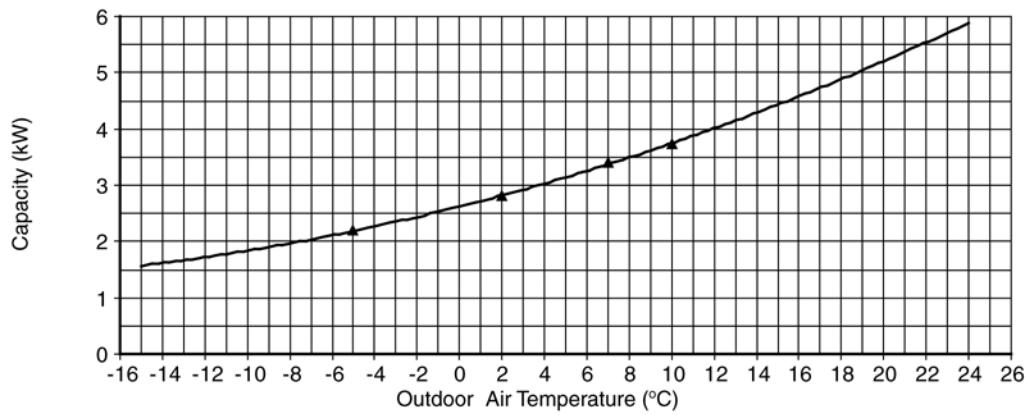
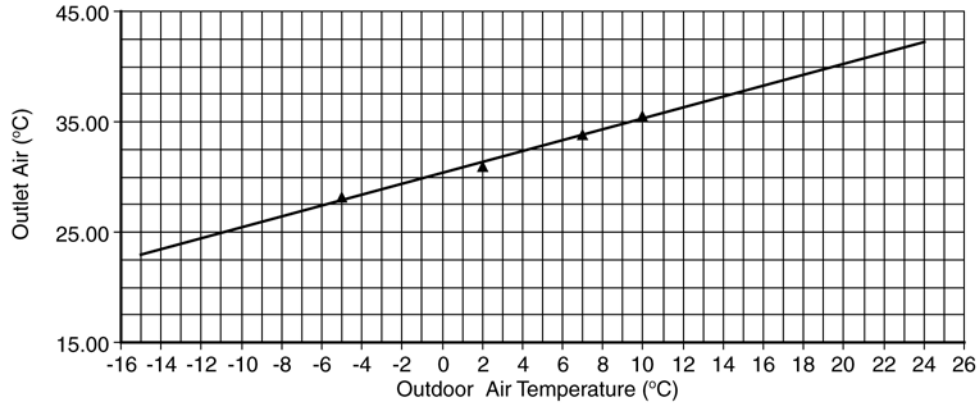

• Piping Length Characteristic

[Condition] Indoor temperature: 20/-°C, 7/6°C
 Remote condition: High fan speed, Heat 30°C
 Comp. Hz: F_h
 Voltage: 230V

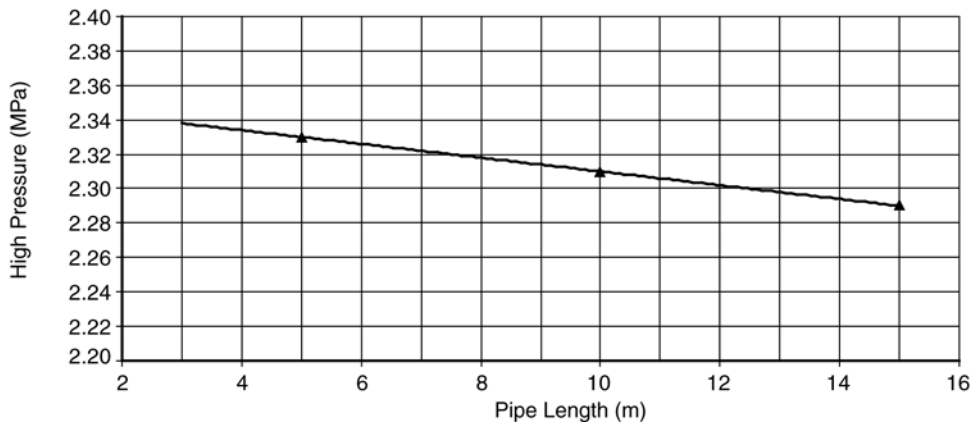
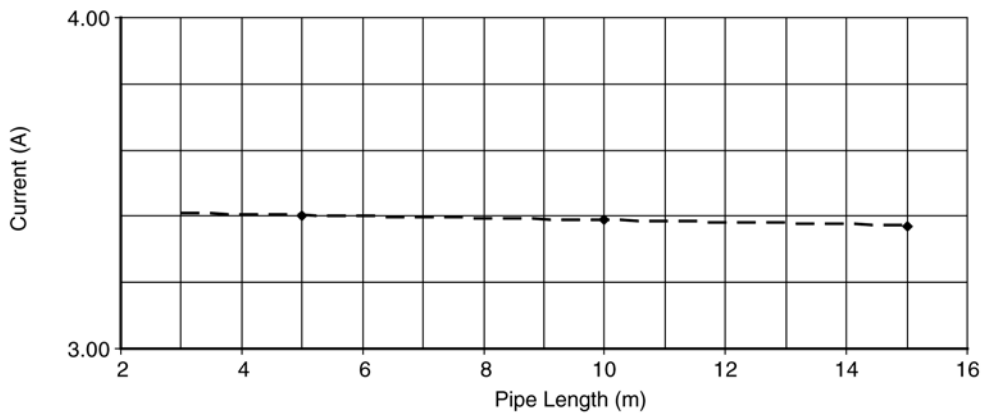
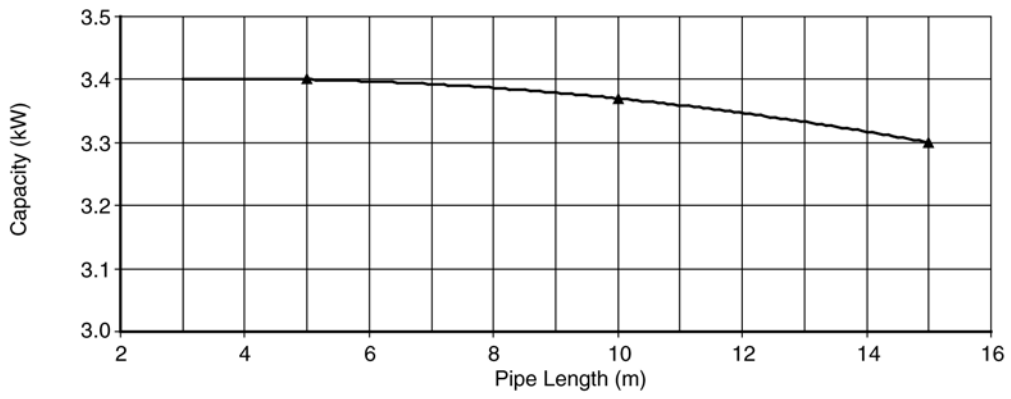
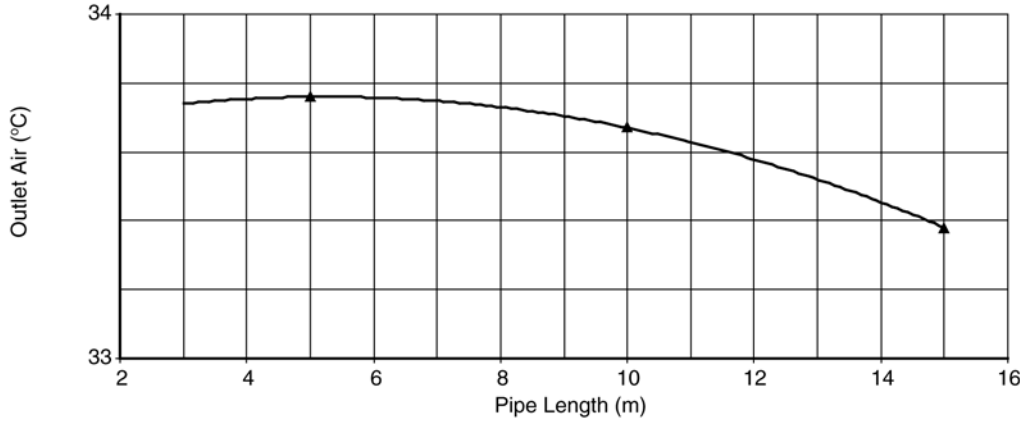

17.1.8. CU-E12JKE-3

• Cooling Characteristic

[Condition] Indoor temperature: 27/19°C
Remote condition: High fan speed, Cool 16°C
Comp. Hz: F_c
Voltage: 230V

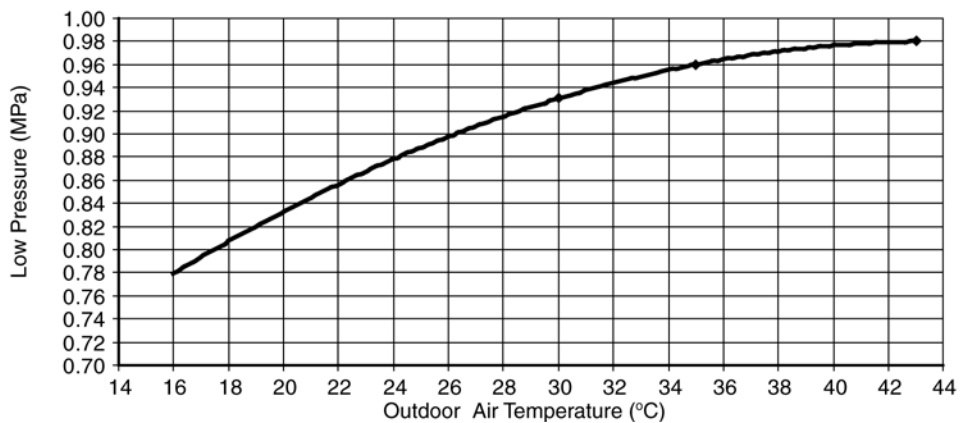
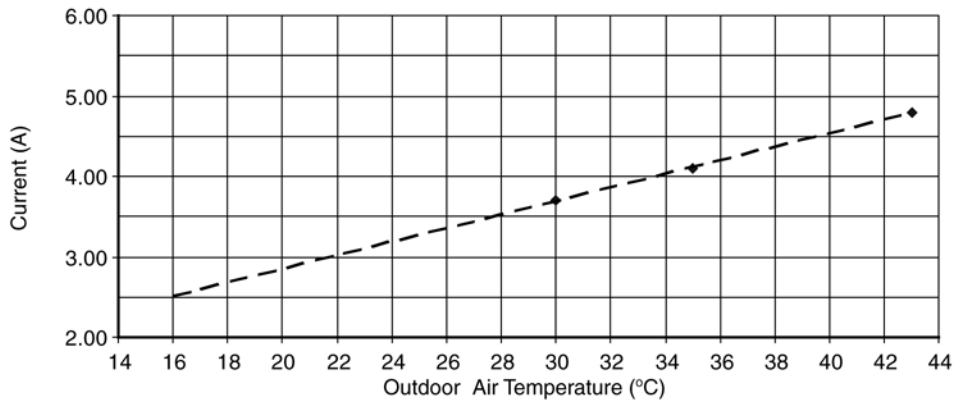
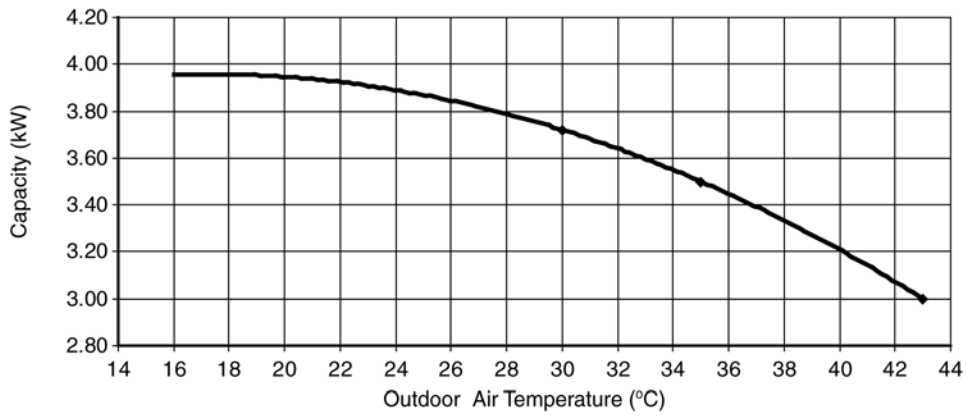
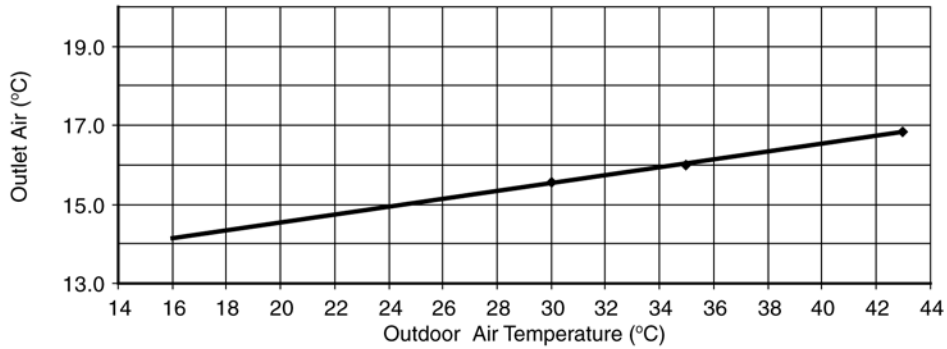

• Piping Length Characteristic

[Condition] Indoor temperature: 27/19°C, 35/-°C
 Remote condition: High fan speed, Cool 16°C
 Comp. Hz: F_c
 Voltage: 230V

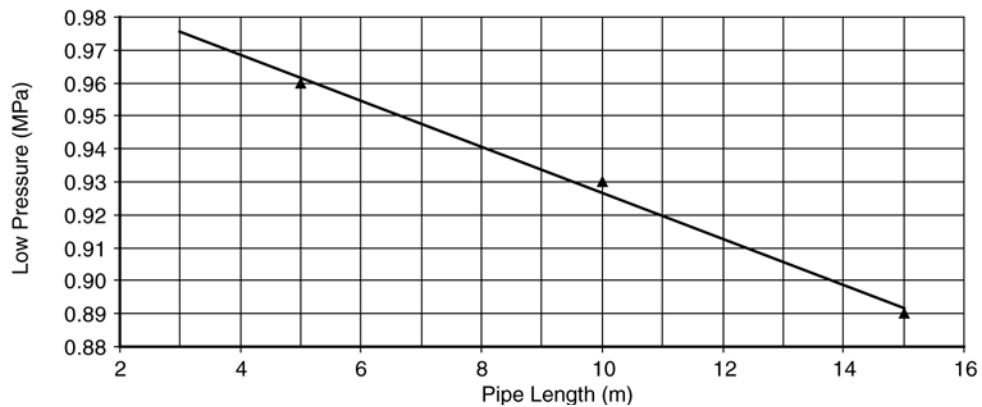
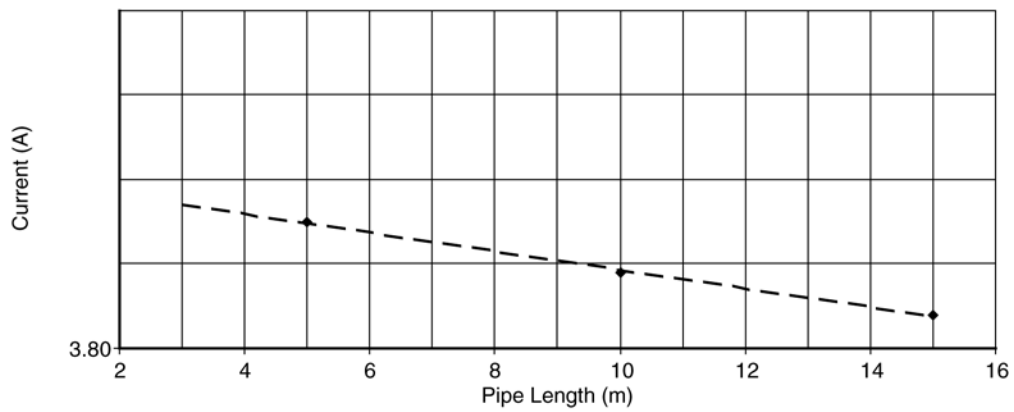
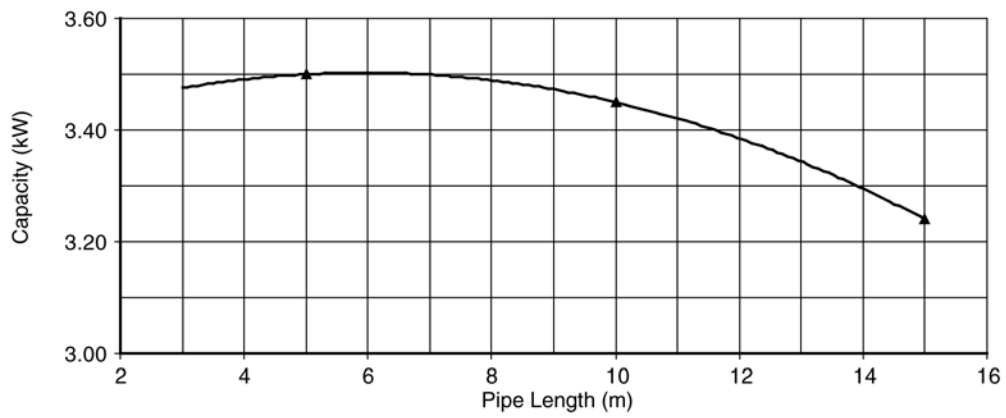
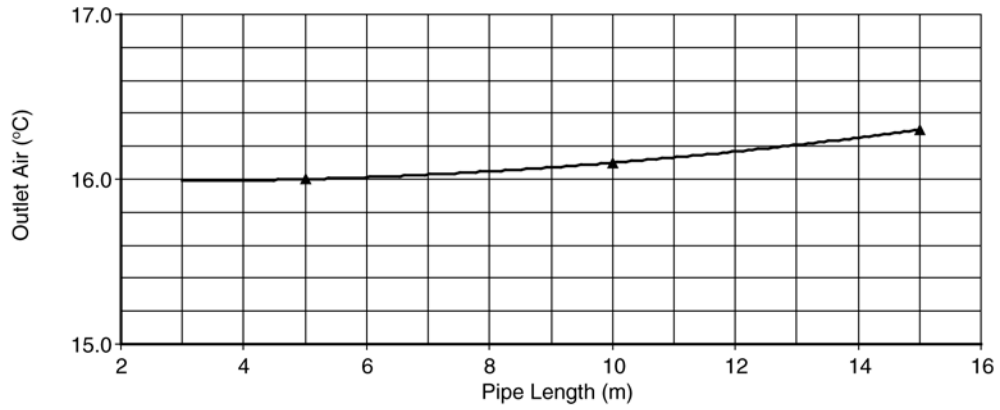

• Heating Characteristic

[Condition] Indoor temperature: 20/-°C

Remote condition: High fan speed, Heat 30°C

Comp. Hz: F_h

Voltage: 230V

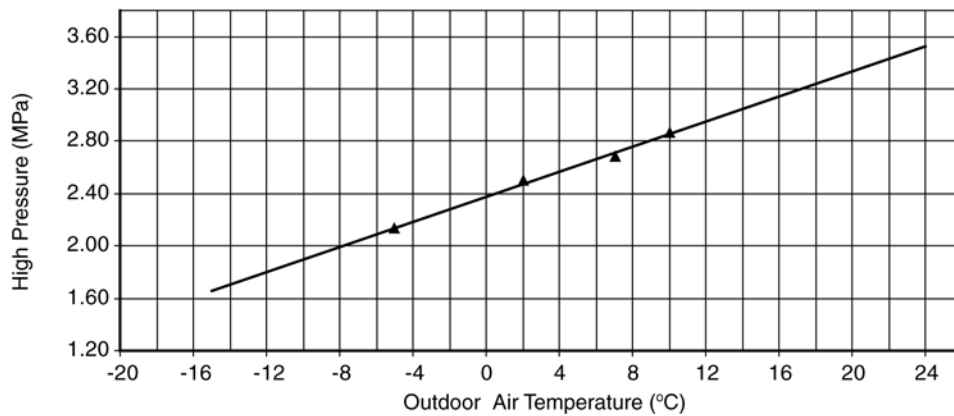
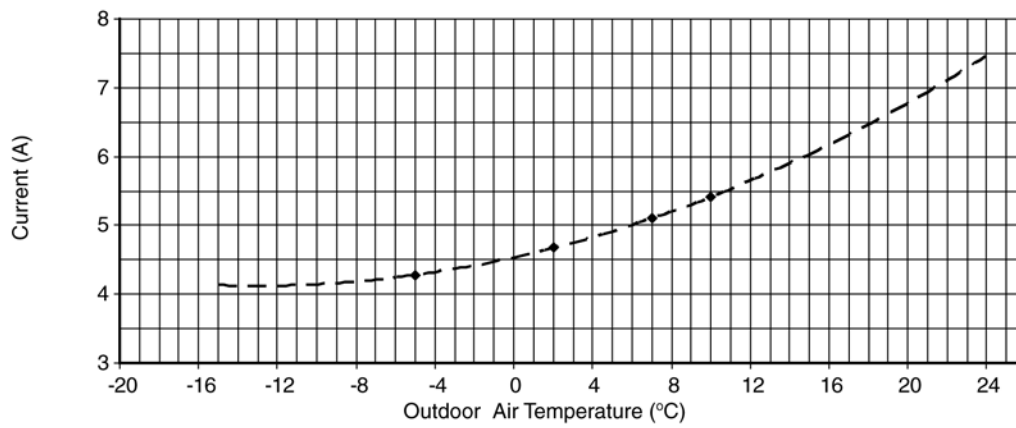
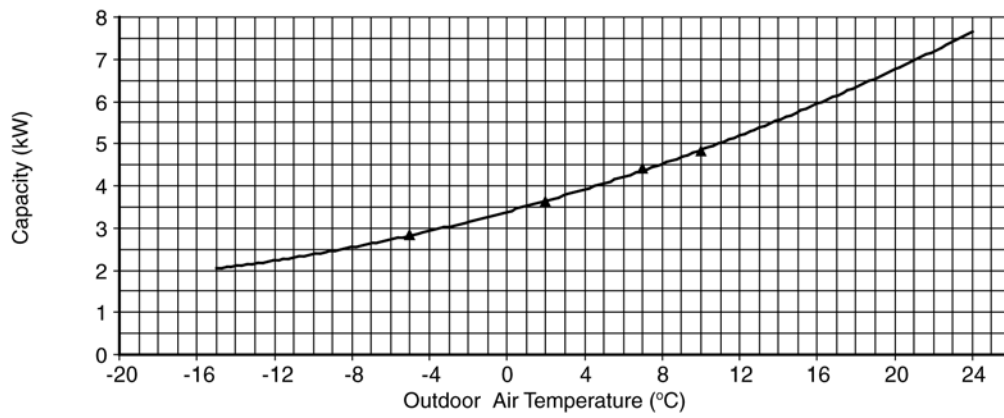
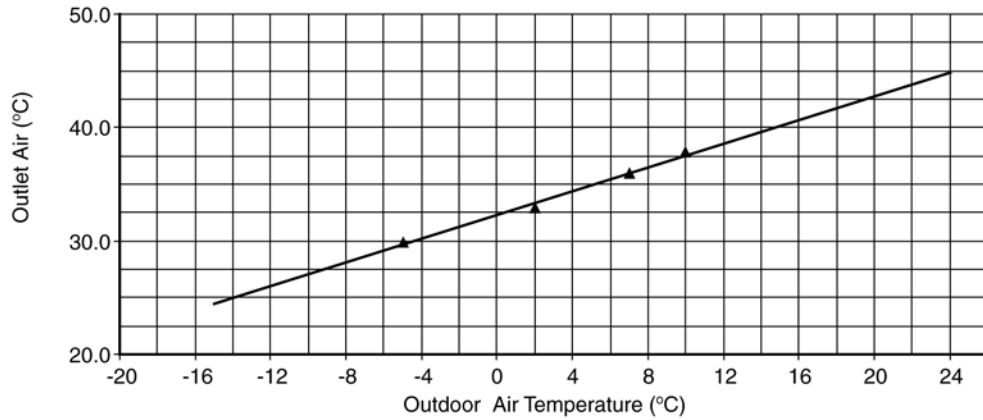

• Piping Length Characteristic

[Condition] Indoor temperature: 20/-°C, 7/6°C
 Remote condition: High fan speed, Heat 30°C
 Comp. Hz: F_h
 Voltage: 230V

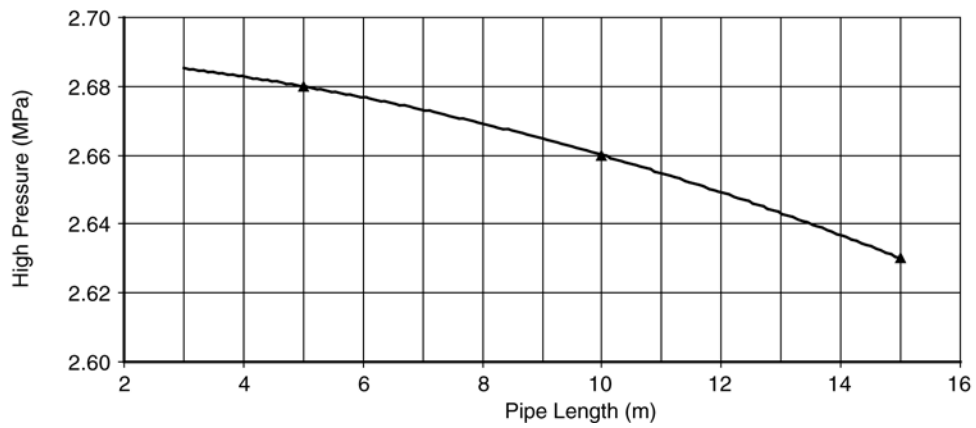
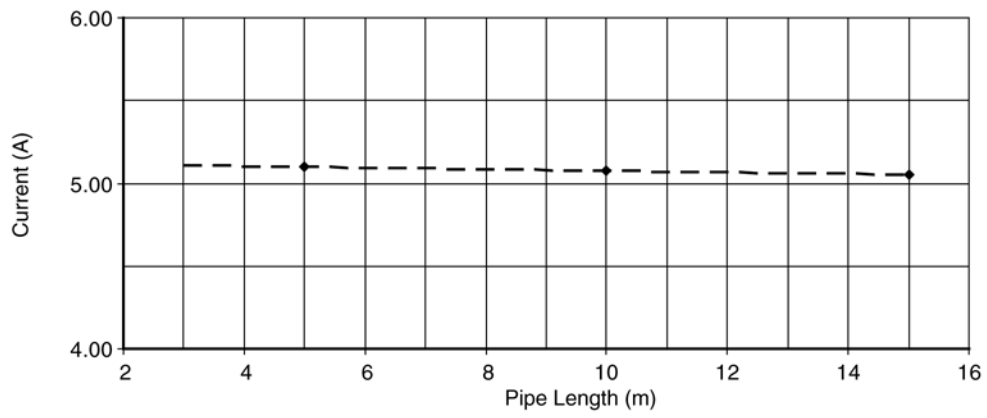
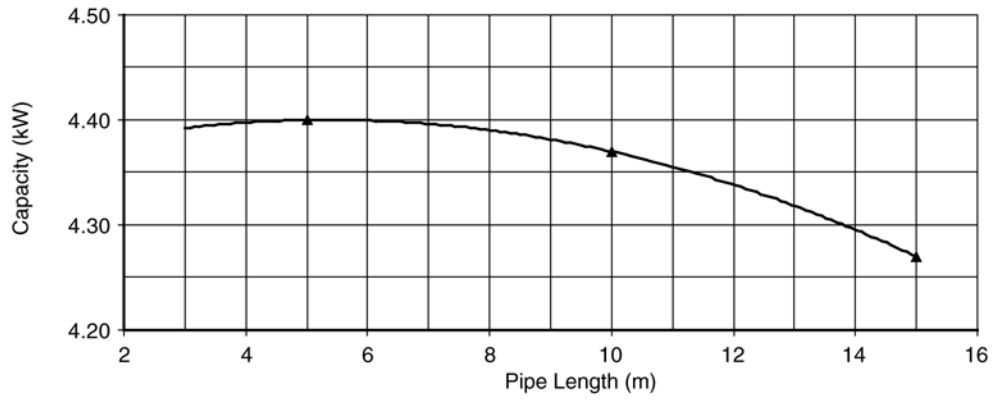
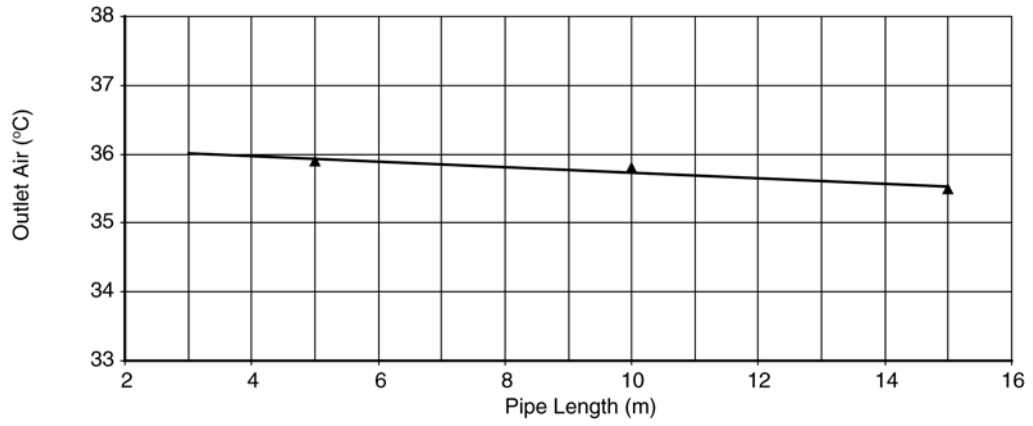

17.2. Sensible Capacity Chart

● CU-E7JKE CU-E7JKE-3

230V Indoor wet bulb temp.	Outdoor Temp. (°C)											
	30			35			40			46		
	TC	SHC	IP	TC	SHC	IP	TC	SHC	IP	TC	SHC	IP
17.0°C	2.03	1.54	0.43	1.90	1.48	0.46	1.77	1.42	0.50	1.61	1.35	0.53
19.0°C				2.05		0.47						
19.5°C	2.23	1.61	0.44	2.09	1.55	0.47	1.94	1.49	0.50	1.77	1.42	0.54
22.0°C	2.43	1.67	0.45	2.27	1.61	0.48	2.12	1.55	0.51	1.92	1.48	0.55

● CU-E9JKE CU-E9JKE-3

230V Indoor wet bulb temp.	Outdoor Temp. (°C)											
	30			35			40			46		
	TC	SHC	IP	TC	SHC	IP	TC	SHC	IP	TC	SHC	IP
17.0°C	2.48	1.88	0.50	2.32	1.80	0.54	2.16	1.73	0.57	1.96	1.65	0.62
19.0°C				2.50		0.55						
19.5°C	2.72	1.97	0.51	2.55	1.89	0.55	2.37	1.82	0.59	2.15	1.73	0.63
22.0°C	2.97	2.04	0.52	2.77	1.96	0.56	2.58	1.89	0.60	2.35	1.81	0.64

● CU-E12JKE CU-E12JKE-3

230V Indoor wet bulb temp.	Outdoor Temp. (°C)											
	30			35			40			46		
	TC	SHC	IP	TC	SHC	IP	TC	SHC	IP	TC	SHC	IP
17.0°C	3.47	2.63	0.83	3.24	2.52	0.89	3.02	2.43	0.95	2.74	2.30	1.03
19.0°C				3.50		0.91						
19.5°C	3.81	2.76	0.84	3.56	2.65	0.91	3.31	2.55	0.97	3.01	2.43	1.05
22.0°C	4.15	2.86	0.86	3.88	2.75	0.92	3.61	2.65	0.99	3.28	2.53	1.07

● CU-E15JKE

230V Indoor wet bulb temp.	Outdoor Temp. (°C)											
	30			35			40			46		
	TC	SHC	IP	TC	SHC	IP	TC	SHC	IP	TC	SHC	IP
17.0°C	4.17	3.16	1.12	3.89	3.03	1.20	3.62	2.91	1.29	3.29	2.77	1.39
19.0°C				4.20		1.22						
19.5°C	4.57	3.31	1.14	4.28	3.18	1.22	3.98	3.06	1.31	3.62	2.91	1.41
22.0°C	4.99	3.43	1.16	4.66	3.30	1.25	4.33	3.18	1.33	3.94	3.03	1.44

● CU-E15JKE-1

230V Indoor wet bulb temp.	Outdoor Temp. (°C)											
	30			35			40			46		
	TC	SHC	IP	TC	SHC	IP	TC	SHC	IP	TC	SHC	IP
17.0°C	4.17	3.16	1.15	3.89	3.03	1.24	3.62	2.91	1.33	3.29	2.77	1.43
19.0°C				4.20		1.26						
19.5°C	4.57	3.31	1.18	4.28	3.18	1.27	3.98	3.06	1.35	3.62	2.91	1.46
22.0°C	4.99	3.43	1.20	4.66	3.30	1.29	4.33	3.18	1.38	3.94	3.03	1.49

TC - Total Cooling Capacity (kW)
 SHC - Sensible Heat Capacity (kW)
 IP - Input Power (kW)

Indoor 27°C/19°C
 Outdoor 35°C/24°C

18 Exploded View and Replacement Parts List

18.1. Indoor Unit

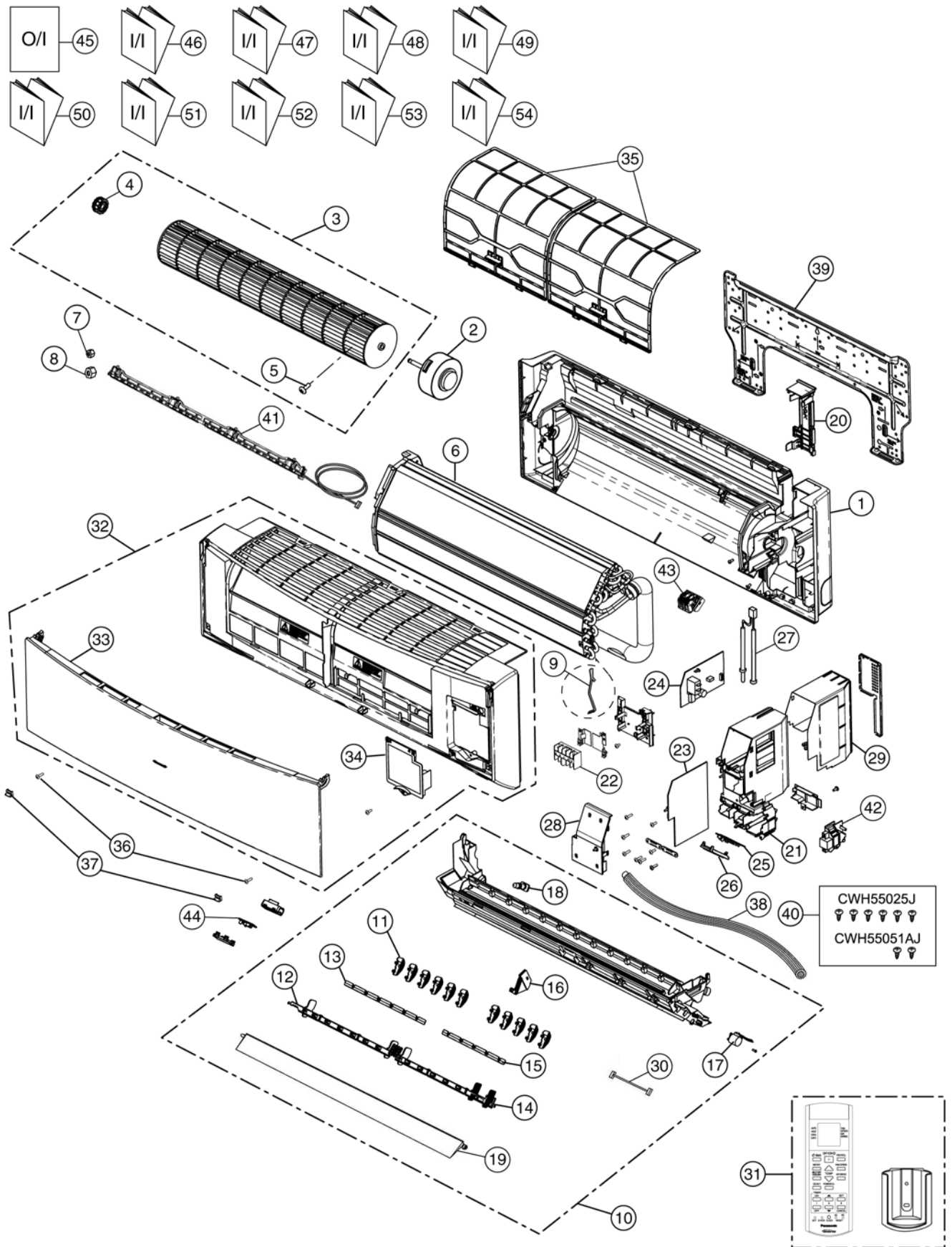

Note
 The above exploded view is for the purpose of parts disassembly and replacement.
 The non-numbered parts are not kept as standard service parts.

REF. NO.	PART NAME & DESCRIPTION	QTY.	CS-E7JKEW	CS-E9JKEW	CS-E12JKEW	CS-E15JKEW	REMARKS
1	CHASSY COMPLETE	1	CWD50C1599	←	←	←	
2	FAN MOTOR	1	L6CBYYL0037	←	←	←	O
3	CROSS FLOW FAN COMPLETE	1	CWH02C1076	←	←	←	
4	BEARING ASSY	1	CWH64K007	←	←	←	
5	SCREW - CROSS FLOW FAN	1	CWH551146	←	←	←	
6	EVAPORATOR CO.	1	CWB30C2960	CWB30C3002	CWB30C2803	CWB30C2945	
7	FLARE NUT (LIQUID)	1	CWT251030	←	←	←	
8	FLARE NUT (GAS)	1	CWT251031	←	←	CWT251032	
9	CLIP FOR SENSOR	1	CWH32143	←	←	←	
10	DISCHARGE GRILLE COMPLETE	1	CWE20C3009	←	←	←	
11	VERTICAL VANE	11	CWE241287	←	←	←	
12	CONNECTING BAR	1	CWE261152	←	←	←	
13	CONNECTING BAR	1	CWE261153	←	←	←	
14	CONNECTING BAR	1	CWE261154	←	←	←	
15	CONNECTING BAR	1	CWE261155	←	←	←	
16	FULCRUM	1	CWH621102	←	←	←	
17	AIR SWING MOTOR	1	CWA981240	←	←	←	O
18	CAP - DRAIN TRAY	1	CWH521096	←	←	←	
19	HORIZONTAL VANE COMPLETE	1	CWE24C1268	←	←	←	
20	BACK COVER CHASSIS	1	CWD933019	←	←	←	
21	CONTROL BOARD CASING	1	CWH102370	←	←	←	
22	TERMINAL BOARD COMPLETE	1	CWA28C2357	←	←	←	O
23	ELECTRONIC CONTROLLER - MAIN	1	CWA73C3769	CWA73C3771	CWA73C3773	CWA73C3775	O
24	ELECTRONIC CONTROLLER - POWER	1	CWA745322	←	←	←	O
25	ELECTRONIC CONTROLLER - INDICATOR	1	CWA745479	←	←	←	O
26	INDICATOR HOLDER	1	CWD933021	←	←	←	
27	SENSOR COMPLETE	1	CWA50C2401	←	←	←	O
28	CONTROL BOARD FRONT COVER	1	CWH13C1183	←	←	←	
29	CONTROL BOARD TOP COVER	1	CWH131350	←	←	←	
30	LEAD WIRE - COMP (A.S.MOTOR)	1	—	←	←	←	
31	REMOTE CONTROL COMPLETE	1	CWA75C3229	←	←	←	O
32	FRONT GRILLE COMPLETE	1	CWE11C4154	←	←	←	O
33	INTAKE GRILLE COMPLETE	1	CWE22C1507	←	←	←	
34	GRILLE DOOR COMPLETE	1	CWE14C1029	←	←	←	
35	E-ION FILTER	2	CWD00K1014	←	←	←	
36	SCREW - FRONT GRILLE	2	XTT4+16CFJ	←	←	←	
37	CAP - FRONT GRILLE	2	CWH521194	←	←	←	
38	DRAIN HOSE	1	CWH851063	←	←	←	
39	INSTALLATION PLATE	1	CWH361097	←	←	←	
40	BAG COMPLETE - INSTALLATION SCREW	1	CWH82C067	←	←	←	
41	E-ION AIR PURIFYING SYSTEM	1	CWD93C1090	←	←	←	
42	ELECTRONIC CONTROLLER - HVU	1	CWA745348	←	←	←	O
43	GENERATOR COMPLETE	1	CWH94C0028	←	←	←	O
44	ELECTRONIC CONTROLLER - RECEIVER	1	CWA745288	←	←	←	
45	OPERATION INSTRUCTIONS	1	CWF566693	←	←	←	
46	INSTALLATION INSTRUCTIONS	1	CWF613869	←	←	←	
47	INSTALLATION INSTRUCTIONS	1	CWF613870	←	←	←	
48	INSTALLATION INSTRUCTIONS	1	CWF613871	←	←	←	
49	INSTALLATION INSTRUCTIONS	1	CWF613872	←	←	←	
50	INSTALLATION INSTRUCTIONS	1	CWF613873	←	←	←	
51	INSTALLATION INSTRUCTIONS	1	CWF613874	←	←	←	
52	INSTALLATION INSTRUCTIONS	1	CWF613875	←	←	←	
53	INSTALLATION INSTRUCTIONS	1	CWF613876	←	←	←	

REF. NO.	PART NAME & DESCRIPTION	QTY.	CS-E7JKEW	CS-E9JKEW	CS-E12JKEW	CS-E15JKEW	REMARKS
54	INSTALLATION INSTRUCTIONS	1	—	←	←	←	

(NOTE)

- All parts are supplied from PHAAM, Malaysia (Vendor Code: 00029488).
- "O" marked parts are recommended to be kept in stock.

REF. NO.	PART NAME & DESCRIPTION	QTY.	CS-XE7JKEW	CS-XE9JKEW	CS-XE12JKEW	CS-XE15JKEW	REMARKS
1	CHASSY COMPLETE	1	CWD50C1605	←	←	←	
2	FAN MOTOR	1	L6CBYYL0037	←	←	←	O
3	CROSS FLOW FAN COMPLETE	1	CWH02C1076	←	←	←	
4	BEARING ASSY	1	CWH64K007	←	←	←	
5	SCREW - CROSS FLOW FAN	1	CWH551146	←	←	←	
6	EVAPORATOR CO.	1	CWB30C2960	CWB30C3002	CWB30C2803	CWB30C2945	
7	FLARE NUT (LIQUID)	1	CWT251030	←	←	←	
8	FLARE NUT (GAS)	1	CWT251031	←	←	CWT251032	
9	CLIP FOR SENSOR	1	CWH32143	←	←	←	
10	DISCHARGE GRILLE COMPLETE	1	CWE20C2920	←	←	←	
11	VERTICAL VANE	11	CWE241287	←	←	←	
12	CONNECTING BAR	1	CWE261152	←	←	←	
13	CONNECTING BAR	1	CWE261153	←	←	←	
14	CONNECTING BAR	1	CWE261154	←	←	←	
15	CONNECTING BAR	1	CWE261155	←	←	←	
16	FULCRUM	1	CWH621102	←	←	←	
17	AIR SWING MOTOR	1	CWA981240	←	←	←	O
18	CAP - DRAIN TRAY	1	CWH521096	←	←	←	
19	HORIZONTAL VANE COMPLETE	1	CWE24C1288	←	←	←	
20	BACK COVER CHASSIS	1	CWD933019A	←	←	←	
21	CONTROL BOARD CASING	1	CWH102370	←	←	←	
22	TERMINAL BOARD COMPLETE	1	CWA28C2357	←	←	←	O
23	ELECTRONIC CONTROLLER - MAIN	1	CWA73C3787	CWA73C3788	CWA73C3790	CWA73C3792	O
24	ELECTRONIC CONTROLLER - POWER	1	CWA745322	←	←	←	O
25	ELECTRONIC CONTROLLER - INDICATOR	1	CWA745479	←	←	←	O
26	INDICATOR HOLDER	1	CWD933021	←	←	←	
27	SENSOR COMPLETE	1	CWA50C2401	←	←	←	O
28	CONTROL BOARD FRONT COVER	1	CWH13C1183	←	←	←	
29	CONTROL BOARD TOP COVER	1	CWH131350	←	←	←	
30	LEAD WIRE - COMP (A.S.MOTOR)	1	—	←	←	←	
31	REMOTE CONTROL COMPLETE	1	CWA75C3229	←	←	←	O
32	FRONT GRILLE COMPLETE	1	CWE11C4173	←	←	←	O
33	INTAKE GRILLE COMPLETE	1	CWE22C1482	←	←	←	
34	GRILLE DOOR COMPLETE	1	CWE14C1038	←	←	←	
35	E-ION FILTER	2	CWD00K1014	←	←	←	
36	SCREW - FRONT GRILLE	2	XTT4+16CFJ	←	←	←	
37	CAP - FRONT GRILLE	2	CWH521194A	←	←	←	
38	DRAIN HOSE	1	CWH851063	←	←	←	
39	INSTALLATION PLATE	1	CWH361097	←	←	←	
40	BAG COMPLETE - INSTALLATION SCREW	1	CWH82C067	←	←	←	
41	E-ION AIR PURIFYING SYSTEM	1	CWD93C1090	←	←	←	
42	ELECTRONIC CONTROLLER - HVU	1	CWA745348	←	←	←	O
43	GENERATOR COMPLETE	1	CWH94C0028	←	←	←	O
44	ELECTRONIC CONTROLLER - RECEIVER	1	CWA745288	←	←	←	
45	OPERATION INSTRUCTIONS	1	CWF566691	←	←	←	
46	INSTALLATION INSTRUCTIONS	1	CWF613869	←	←	←	
47	INSTALLATION INSTRUCTIONS	1	CWF613870	←	←	←	
48	INSTALLATION INSTRUCTIONS	1	CWF613871	←	←	←	
49	INSTALLATION INSTRUCTIONS	1	CWF613872	←	←	←	
50	INSTALLATION INSTRUCTIONS	1	CWF613873	←	←	←	
51	INSTALLATION INSTRUCTIONS	1	CWF613874	←	←	←	
52	INSTALLATION INSTRUCTIONS	1	CWF613875	←	←	←	
53	INSTALLATION INSTRUCTIONS	1	CWF613876	←	←	←	

REF. NO.	PART NAME & DESCRIPTION	QTY.	CS-XE7JKEW	CS-XE9JKEW	CS-XE12JKEW	CS-XE15JKEW	REMARKS
54	INSTALLATION INSTRUCTIONS	1	CWF613877	←	←	—	

(NOTE)

- All parts are supplied from PHAAM, Malaysia (Vendor Code: 00029488).
- "O" marked parts are recommended to be kept in stock.

REF. NO.	PART NAME & DESCRIPTION	QTY.	CS-E7JKEW-3	CS-E9JKEW-3	CS-E12JKEW-3	REMARKS
1	CHASSY COMPLETE	1	CWD50C1599	←	←	
2	FAN MOTOR	1	L6CBYYL0037	←	←	O
3	CROSS FLOW FAN COMPLETE	1	CWH02C1076	←	←	
4	BEARING ASSY	1	CWH64K007	←	←	
5	SCREW - CROSS FLOW FAN	1	CWH551146	←	←	
6	EVAPORATOR CO.	1	CWB30C2960	CWB30C3002	CWB30C2803	
7	FLARE NUT (LIQUID)	1	CWT251030	←	←	
8	FLARE NUT (GAS)	1	CWT251031	←	←	
9	CLIP FOR SENSOR	1	CWH32143	←	←	
10	DISCHARGE GRILLE COMPLETE	1	CWE20C3009	←	←	
11	VERTICAL VANE	11	CWE241287	←	←	
12	CONNECTING BAR	1	CWE261152	←	←	
13	CONNECTING BAR	1	CWE261153	←	←	
14	CONNECTING BAR	1	CWE261154	←	←	
15	CONNECTING BAR	1	CWE261155	←	←	
16	FULCRUM	1	CWH621102	←	←	
17	AIR SWING MOTOR	1	CWA981240	←	←	O
18	CAP - DRAIN TRAY	1	CWH521096	←	←	
19	HORIZONTAL VANE COMPLETE	1	CWE24C1268	←	←	
20	BACK COVER CHASSIS	1	CWD933019	←	←	
21	CONTROL BOARD CASING	1	CWH102370	←	←	
22	TERMINAL BOARD COMPLETE	1	CWA28C2357	←	←	O
23	ELECTRONIC CONTROLLER - MAIN	1	CWA73C3769	CWA73C3771	CWA73C3773	O
24	ELECTRONIC CONTROLLER - POWER	1	CWA745322	←	←	O
25	ELECTRONIC CONTROLLER - INDICATOR	1	CWA745479	←	←	O
26	INDICATOR HOLDER	1	CWD933021	←	←	
27	SENSOR COMPLETE	1	CWA50C2401	←	←	O
28	CONTROL BOARD FRONT COVER	1	CWH13C1183	←	←	
29	CONTROL BOARD TOP COVER	1	CWH131350	←	←	
30	LEAD WIRE - COMP (A.S.MOTOR)	1	—	←	←	
31	REMOTE CONTROL COMPLETE	1	CWA75C3229	←	←	O
32	FRONT GRILLE COMPLETE	1	CWE11C4154	←	←	O
33	INTAKE GRILLE COMPLETE	1	CWE22C1507	←	←	
34	GRILLE DOOR COMPLETE	1	CWE14C1029	←	←	
35	E-ION FILTER	2	CWD00K1014	←	←	
36	SCREW - FRONT GRILLE	2	XTT4+16CFJ	←	←	
37	CAP - FRONT GRILLE	2	CWH521194	←	←	
38	DRAIN HOSE	1	CWH851063	←	←	
39	INSTALLATION PLATE	1	CWH361097	←	←	
40	BAG COMPLETE - INSTALLATION SCREW	1	CWH82C067	←	←	
41	E-ION AIR PURIFYING SYSTEM	1	CWD93C1090	←	←	
42	ELECTRONIC CONTROLLER - HVU	1	CWA745348	←	←	O
43	GENERATOR COMPLETE	1	CWH94C0028	←	←	O
44	ELECTRONIC CONTROLLER - RECEIVER	1	CWA745288	←	←	
45	OPERATION INSTRUCTIONS	1	CWF566694	←	←	
46	INSTALLATION INSTRUCTIONS	1	CWF613869	←	←	
47	INSTALLATION INSTRUCTIONS	1	CWF613870	←	←	
48	INSTALLATION INSTRUCTIONS	1	CWF613871	←	←	
49	INSTALLATION INSTRUCTIONS	1	CWF613872	←	←	
50	INSTALLATION INSTRUCTIONS	1	CWF613873	←	←	
51	INSTALLATION INSTRUCTIONS	1	CWF613874	←	←	
52	INSTALLATION INSTRUCTIONS	1	CWF613875	←	←	
53	INSTALLATION INSTRUCTIONS	1	CWF613876	←	←	

REF. NO.	PART NAME & DESCRIPTION	QTY.	CS-E7JKEW-3	CS-E9JKEW-3	CS-E12JKEW-3	REMARKS
54	INSTALLATION INSTRUCTIONS	1	CWF613877	←	←	

(NOTE)

- All parts are supplied from PHAAM, Malaysia (Vendor Code: 00029488).
- "O" marked parts are recommended to be kept in stock.

18.2. Outdoor Unit

18.2.1. CU-E7JKE CU-E9JKE CU-E12JKE CU-E15JKE-1 CU-E7JKE-3 CU-E9JKE-3 CU-E12JKE-3

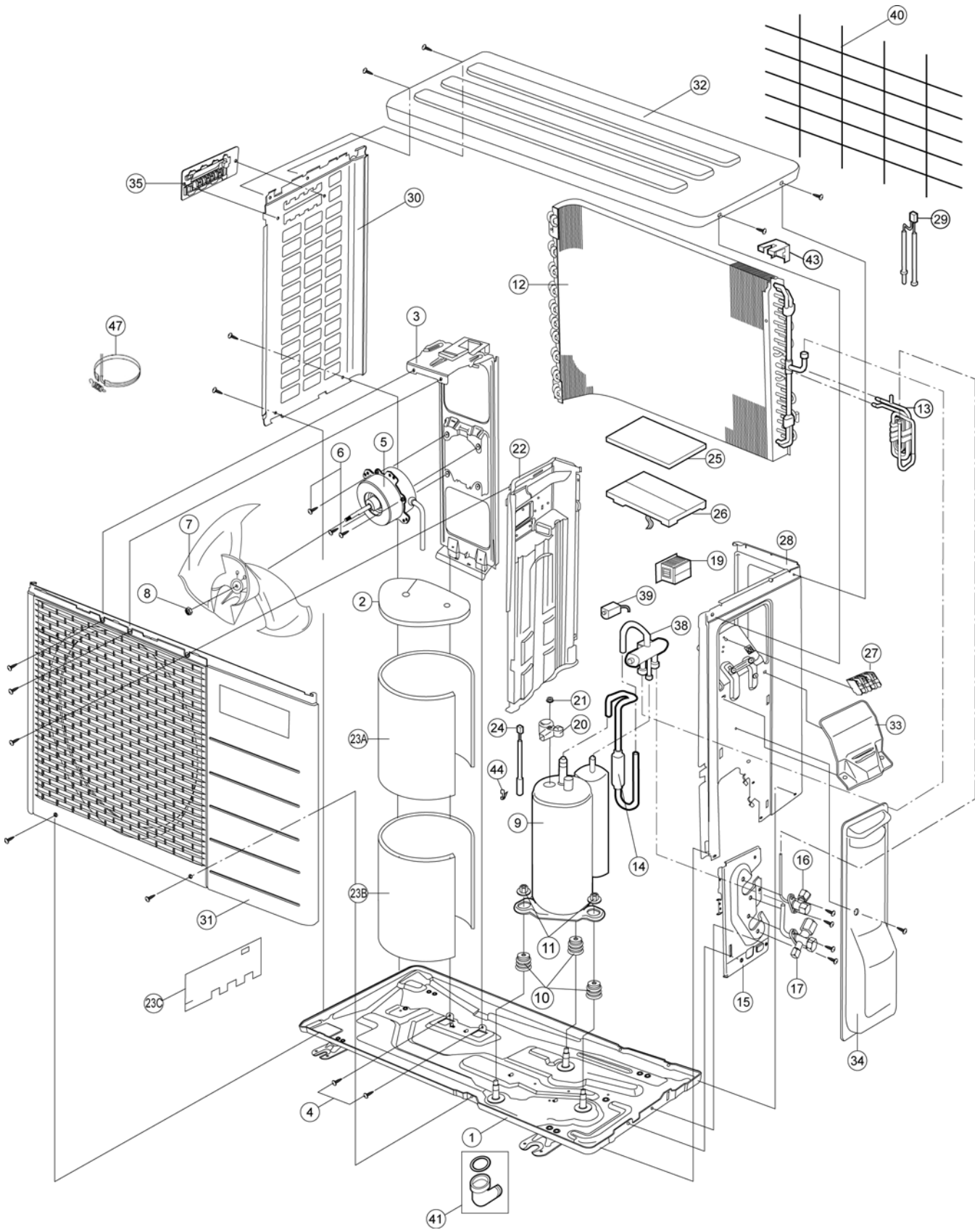

Note

The above exploded view is for the purpose of parts disassembly and replacement.
The non-numbered parts are not kept as standard service parts.

REF. NO.	PART NAME & DESCRIPTION	QTY.	CU-E7JKE	CU-E9JKE	CU-E12JKE	CU-E15JKE-1	REMARKS
1	CHASSY ASS'Y	1	CWD50K2073	←	←	←	
2	SOUND PROOF MATERIAL	1	CWG302447	—	—	—	
3	FAN MOTOR BRACKET	1	CWD541089	←	←	←	
4	SCREW - FAN MOTOR BRACKET	2	CWH551217	←	←	←	
5	FAN MOTOR	1	CWA951536	CWA951553	CWA951542	CWA951555	O
6	SCREW - FAN MOTOR MOUNT	4	CWH55406J	←	←	CWH55252J	
7	PROPELLER FAN ASS'Y	1	CWH03K1010	←	←	←	
8	NUT - PROPELLER FAN	1	CWH56053J	←	←	←	
9	COMPRESSOR	1	5RS092XCD01	5RS102XBC01	←	←	O
10	ANTI - VIBRATION BUSHING	3	CWH50077	←	←	←	
11	NUT - COMPRESSOR MOUNT	3	CWH56000J	←	←	←	
12	CONDENSER	1	CWB32C2485	CWB32C2448	←	←	
13	TUBE ASS'Y CO. (CAP. / CHK VALVE)	1	CWT01C4849	CWT01C4850	CWT01C4851	CWT01C4852	
14	DISCHARGE MUFFLER	1	CWB121010	←	←	←	
15	HOLDER COUPLING	1	CWH351023	←	←	←	
16	2-WAYS VALVE (LIQUID)	1	CWB021301	←	←	←	O
17	3-WAYS VALVE (GAS)	1	CWB011374	←	←	CWB011367	O
19	REACTOR	1	G0C193J00003	G0C193J00002	G0C193J00004	←	O
20	TERMINAL COVER	1	CWH171039A	←	←	←	
21	NUT - TERMINAL COVER	1	CWH7080300J	←	←	←	
22	SOUND PROOF BOARD	1	CWH151172	←	←	←	
23A	SOUND PROOF MATERIAL	1	CWG302443	CWG302292	←	←	
23B	SOUND PROOF MATERIAL	1	—	CWG302293	←	←	
24	SENSOR COMPLETE	1	CWA50C2205	←	←	←	O
25	CONTROL BOARD COVER	1	CWH131264	←	←	←	
26	ELECTRONIC CONTROLLER - MAIN	1	CWA73C3797R	CWA73C3798R	CWA73C3799R	CWA73C3803R	O
27	TERMINAL BOARD ASS'Y	1	CWA28K1110J	←	←	←	O
28	CABINET SIDE PLATE CO.	1	CWE04C1116	←	←	←	
29	SENSOR COMPLETE	1	CWA50C2391	←	←	←	O
30	CABINET SIDE PLATE	1	CWE041248A	←	←	←	
31	CABINET FRONT PLATE CO.	1	CWE06C1039	←	←	←	
32	CABINET TOP PLATE	1	CWE031014A	←	←	←	
33	PLATE - C. B. COVER	1	CWH131301	←	←	←	
34	CONTROL BOARD COVER CO.	1	CWH13C1064	←	←	←	
35	HANDLE	1	CWE161010	←	←	←	
38	4-WAYS VALVE	1	CWB001037J	←	←	←	O
39	V - COIL COMPLETE	1	CWA43C2143J	←	←	←	O
40	WIRE NET	1	CWD041111A	←	←	←	
41	ACCESSORY CO. (DRAIN ELBOW)	1	CWG87C900	←	←	←	
43	HOLDER SENSOR	1	—	—	—	CWH321023	
44	HOLDER SENSOR	1	—	—	—	CWH32143	

(NOTE)

- All parts are supplied from PHAAM, Malaysia (Vendor Code: 00029488).
- "O" marked parts are recommended to be kept in stock.

REF. NO.	PART NAME & DESCRIPTION	QTY.	CU-E7JKE-3	CU-E9JKE-3	CU-E12JKE-3	REMARKS
1	CHASSY ASS'Y	1	CWD50K2073	←	←	
2	SOUND PROOF MATERIAL	1	CWG302314	←	←	
3	FAN MOTOR BRACKET	1	CWD541089	←	←	
4	SCREW - FAN MOTOR BRACKET	2	CWH551217	←	←	
5	FAN MOTOR	1	CWA951536	CWA951553	CWA951542	O
6	SCREW - FAN MOTOR MOUNT	4	CWH55406J	←	←	
7	PROPELLER FAN ASS'Y	1	CWH03K1010	←	←	
8	NUT - PROPELLER FAN	1	CWH56053J	←	←	
9	COMPRESSOR	1	5RS092XCD01	5RS102XBC01	←	O
10	ANTI - VIBRATION BUSHING	3	CWH50077	←	←	
11	NUT - COMPRESSOR MOUNT	3	CWH56000J	←	←	
12	CONDENSER	1	CWB32C2485	CWB32C2448	←	
13	TUBE ASS'Y CO. (CAP. / CHK VALVE)	1	CWT01C4849	CWT01C4850	CWT01C4851	
14	DISCHARGE MUFFLER	1	CWB121010	←	←	
15	HOLDER COUPLING	1	CWH351023	←	←	
16	2-WAYS VALVE (LIQUID)	1	CWB021301	←	←	O
17	3-WAYS VALVE (GAS)	1	CWB011374	←	←	O
19	REACTOR	1	G0C193J00003	←	G0C193J00004	O
20	TERMINAL COVER	1	CWH171039A	←	←	
21	NUT - TERMINAL COVER	1	CWH7080300J	←	←	
22	SOUND PROOF BOARD	1	CWH151172	←	←	
23A	SOUND PROOF MATERIAL	1	CWG302316	←	←	
23B	SOUND PROOF MATERIAL	1	CWG302317	←	←	
23C	SOUND PROOF MATERIAL	1	CWG302315	←	←	
24	SENSOR COMPLETE	1	CWA50C2205	←	←	O
25	CONTROL BOARD COVER	1	CWH131264	←	←	
26	ELECTRONIC CONTROLLER - MAIN	1	CWA73C3800R	CWA73C3801R	CWA73C3802R	O
27	TERMINAL BOARD ASS'Y	1	CWA28K1110J	←	←	O
28	CABINET SIDE PLATE CO.	1	CWE04C1116	←	←	
29	SENSOR COMPLETE	1	CWA50C2391	←	←	O
30	CABINET SIDE PLATE	1	CWE041248A	←	←	
31	CABINET FRONT PLATE CO.	1	CWE06C1039	CWE06C1136	←	
32	CABINET TOP PLATE	1	CWE031014A	←	←	
33	PLATE - C. B. COVER	1	CWH131301	←	←	
34	CONTROL BOARD COVER CO.	1	CWH13C1064	←	←	
35	HANDLE	1	CWE161010	←	←	
38	4-WAYS VALVE	1	CWB001037J	←	←	O
39	V - COIL COMPLETE	1	CWA43C2143J	←	←	O
40	WIRE NET	1	CWD041111A	←	←	
41	ACCESSORY CO. (DRAIN ELBOW)	1	CWG87C900	←	←	
47	CRANKCASE HEATER	1	CWA341044	←	←	

(NOTE)

- All parts are supplied from PHAAM, Malaysia (Vendor Code: 00029488).
- "O" marked parts are recommended to be kept in stock.

18.2.2. CU-E15JKE

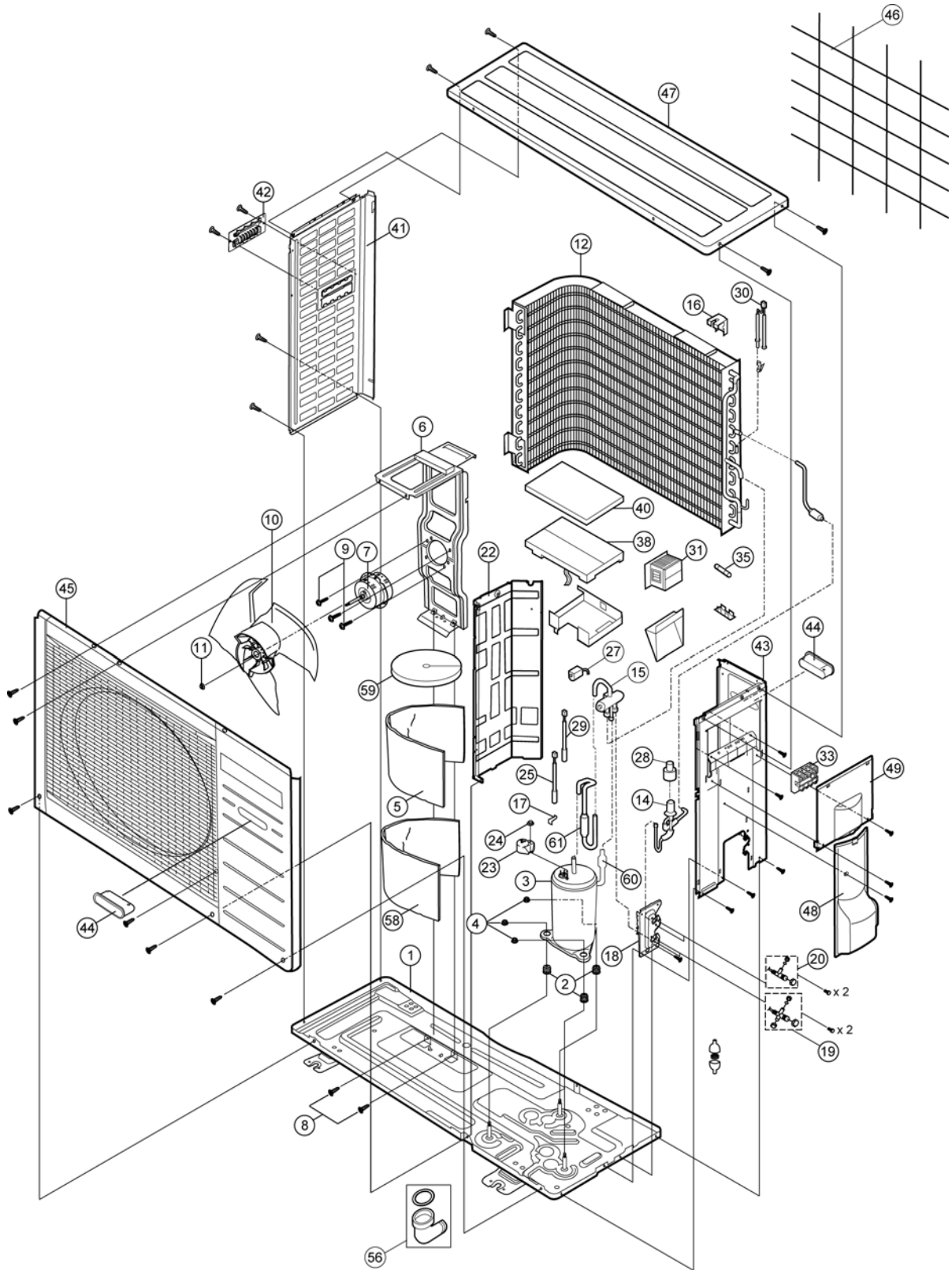

Note

The above exploded view is for the purpose of parts disassembly and replacement.
The non-numbered parts are not kept as standard service parts.

REF. NO.	DESCRIPTION & NAME	QTY.	CU-E15JKE	REMARKS
1	CHASSY ASS'Y	1	CWD50K2085	
2	ANTI-VIBRATION BUSHING	3	CWH50077	
3	COMPRESSOR	1	5CS130XAD04	O
4	NUT-COMPRESSOR MOUNT	3	CWH56000J	
5	SOUND PROOF MATERIAL	1	CWG302302	
6	FAN MOTOR BRACKET	1	CWD541084	
7	FAN MOTOR	1	CWA981166J	O
8	SCREW - FAN MOTOR BRACKET	2	CWH551217	
9	SCREW - FAN MOTOR MOUNT	4	CWH55252J	
10	PROPELLER FAN ASSY	1	CWH03K1016	
11	NUT - PROPELLER FAN	1	CWH56053J	
12	CONDENSER	1	CWB32C2817	
14	EXPANSION VALVE	1	CWB051016J	O
15	4 WAYS VALVE	1	CWB001026J	
16	HOLDER SENSOR	1	CWMH320001	
17	HOLDER SENSOR	1	CWH32074	
18	HOLDER - COUPLING	1	CWH351056	
19	3 WAYS VALVE (GAS)	1	CWB011361	O
20	2 WAYS VALVE (LIQUID)	1	CWB021292	O
22	SOUND PROOF BOARD	1	CWH151050	
23	TERMINAL COVER	1	CWH171039A	
24	NUT-TERMINAL COVER	1	CWH7080300J	
25	SENSOR COMPLETE (COMP. TOP)	1	CWA50C2185	
27	V-COIL COMPLETE (4 - WAYS VALVE)	1	CWA43C2168J	
28	V-COIL COMPLETE (EXPAND VALVE)	1	CWA43C2058J	
29	SENSOR COMPLETE (COMP. DISC.)	1	CWA50C2180	
30	SENSOR COMPLETE	1	CWA50C2181	
31	REACTOR	1	G0C203J00003	
33	TERMINAL BOARD ASSY	1	CWA28K1110J	
35	FUSE	1	K5D303BBA002	
38	ELECTRONIC CONTROLLER - MAIN	1	CWA73C3804R	O
40	CONTROL BOARD COVER (TOP)	1	CWH131167	
41	CABINET SIDE PLATE (LEFT)	1	CWE041255A	
42	HANDLE	1	CWE161010	
43	CABINET SIDE PLATE (RIGHT)	1	CWE041158A	
44	HANDLE	2	CWE16000E	
45	CABINET FRONT PLATE CO.	1	CWE06K1043	
46	WIRE NET	1	CWD041041A	
47	CABINET TOP PLATE	1	CWE031031A	
48	CONTROL BOARD COVER (BOTTOM)	1	CWH131168	
49	CONTROL BOARD COVER (TOP)	1	CWH131169A	
56	ACCESSORY CO. (DRAIN ELBOW)	1	CWG87C900	
58	SOUND PROOF MATERIAL	1	CWG302290	
59	SOUND PROOF MATERIAL	1	CWG302301	
60	ACCUMULATOR	1	CWB131024	
61	RECEIVER	1	CWB14011	

(NOTE)

- All parts are supplied from PHAAM, Malaysia (Vendor Code: 00029488).
- "O" marked parts are recommended to be kept in stock.