

## SERVICE MANUAL

## 2WAY SYSTEM

**R410A**



### Model No. Outdoor Unit

Class		8HP	10HP	12HP	14HP	16HP	18HP	20HP
ME1	Model Name	U-8ME1E8	U-10ME1E8	U-12ME1E8	U-14ME1E8	U-16ME1E8	U-18ME1E8	U-20ME1E8
		U-8ME1E8E	U-10ME1E8E	U-12ME1E8E	U-14ME1E8E	U-16ME1E8E	U-18ME1E8E	U-20ME1E8E

### Indoor Unit

Class		22	28	36	45	56	73	90	106	140	160
U1	4-Way Cassette	S-22MU1E5	S-28MU1E5	S-36MU1E5	S-45MU1E5	S-56MU1E5	S-73MU1E5		S-106MU1E5	S-140MU1E5	S-160MU1E5
Y1	4-Way Cassette 60×60	S-22MY1E5	S-28MY1E5	S-36MY1E5	S-45MY1E5	S-56MY1E5					
L1	2-Way Cassette	S-22ML1E5	S-28ML1E5	S-36ML1E5	S-45ML1E5	S-56ML1E5	S-73ML1E5				
D1	1-Way Cassette		S-28MD1E5	S-36MD1E5	S-45MD1E5	S-56MD1E5	S-73MD1E5				
F1	Low Silhouette Ducted	S-22MF1E5	S-28MF1E5	S-36MF1E5	S-45MF1E5	S-56MF1E5	S-73MF1E5	S-90MF1E5	S-106MF1E5	S-140MF1E5	S-160MF1E5
M1	Slim Low Static Ducted	S-22MM1E5	S-28MM1E5	S-36MM1E5	S-45MM1E5	S-56MM1E5					
T1	Ceiling			S-36MT1E5	S-45MT1E5	S-56MT1E5	S-73MT1E5		S-106MT1E5	S-140MT1E5	
K1	Wall Mounted	S-22MK1E5	S-28MK1E5	S-36MK1E5	S-45MK1E5	S-56MK1E5	S-73MK1E5		S-106MK1E5		
R1	Concealed Floor Standing	S-22MR1E5	S-28MR1E5	S-36MR1E5	S-45MR1E5	S-56MR1E5	S-71MR1E5				
P1	Floor Standing	S-22MP1E5	S-28MP1E5	S-36MP1E5	S-45MP1E5	S-56MP1E5	S-71MP1E5				

Class		73	106	140	224	280
E1	High Static Pressure Ducted	S-73ME1E5	S-106ME1E5	S-140ME1E5	S-224ME1E5	S-280ME1E5

# IMPORTANT!

## Please Read Before Starting

This air conditioning system meets strict safety and operating standards. As the installer or service person, it is an important part of your job to install or service the system so it operates safely and efficiently.

### For safe installation and trouble-free operation, you must:

- Carefully read this instruction booklet before beginning.
- Follow each installation or repair step exactly as shown.
- Observe all local, state, and national electrical codes.
- This product is intended for professional use. Permission from the power supplier is required when installing the U-8ME1E8 (E) outdoor unit that is connected to a 16 A distribution network.
- This equipment complies with EN/IEC 61000-3-12 provided that the short-circuit power  $S_{sc}$  is greater than or equals to the values corresponding to each model as shown in the table below at the interface point between the user's supply and the public system. It is the responsibility of the installer or user of the equipment to ensure; by consultation with the distribution network operator if necessary that the equipment is connected only to supply with a short-circuit power  $S_{sc}$  greater than or equals to the values corresponding to each model as shown in the table below.

	U-10ME1E8(E)	U-12ME1E8(E)	U-14ME1E8(E)	U-16ME1E8(E)	U-18ME1E8(E)	U-20ME1E8(E)
$S_{sc}$	1,660 kW	1,660 kW	1,510 kW	1,510 kW	1,690 kW	1,690 kW

- This equipment complies with EN/IEC 61000-3-11 provided that the system impedance  $Z_{max}$  is less than or equals to the values corresponding to each model as shown in the table below at the interface point between the user's supply and the public system. Consult to the supply authority for the system impedance  $Z_{max}$ .

	U-10ME1E8(E)	U-12ME1E8(E)	U-14ME1E8(E)	U-16ME1E8(E)	U-18ME1E8(E)	U-20ME1E8(E)
$Z_{max}$	0.194 $\Omega$	0.194 $\Omega$	0.194 $\Omega$	0.194 $\Omega$	0.194 $\Omega$	0.194 $\Omega$

- Pay close attention to all warning and caution notices given in this manual.



**WARNING**

This symbol refers to a hazard or unsafe practice which can result in severe personal injury or death.



**CAUTION**

This symbol refers to a hazard or unsafe practice which can result in personal injury or product or property damage.

### If Necessary, Get Help

These instructions are all you need for most installation sites and maintenance conditions. If you require help for a special problem, contact our sales/service outlet or your certified dealer for additional instructions.

### In Case of Improper Installation

The manufacturer shall in no way be responsible for improper installation or maintenance service, including failure to follow the instructions in this document.

## SPECIAL PRECAUTIONS

### WARNING When Wiring



**ELECTRICAL SHOCK CAN CAUSE SEVERE PERSONAL INJURY OR DEATH. ONLY A QUALIFIED, EXPERIENCED ELECTRICIAN SHOULD ATTEMPT TO WIRE THIS SYSTEM.**

- Do not supply power to the unit until all wiring and tubing are completed or reconnected and checked.
- Highly dangerous electrical voltages are used in this system. Carefully refer to the wiring diagram and these instructions when wiring. Improper connections and inadequate grounding can cause **accidental injury or death**.
- **Ground the unit** following local electrical codes.
- Connect all wiring tightly. Loose wiring may cause overheating at connection points and a possible fire hazard.
- Provide a power outlet to be used exclusively for each unit, and a power supply disconnect, circuit breaker and earth leakage breaker for overcurrent protection should be provided in the exclusive line.
- Provide a power outlet exclusively for each unit, and full disconnection mean having a contact separation in all poles must be incorporated in the fixed wiring in accordance with the wiring rules.
- To prevent possible hazards from insulation failure, the unit must be grounded. 

### When Transporting

Be careful when picking up and moving the indoor and outdoor units. Get a partner to help, and bend your knees when lifting to reduce strain on your back. Sharp edges or thin aluminum fins on the air conditioner can cut your fingers.

### When Installing...

#### ...In a Room

Properly insulate any tubing run inside a room to prevent "sweating" that can cause dripping and water damage to walls and floors.



**CAUTION**

Keep the fire alarm and the air outlet at least 1.5 m away from the unit.

#### ...In Moist or Uneven Locations

Use a raised concrete pad or concrete blocks to provide a solid, level foundation for the outdoor unit. This prevents water damage and abnormal vibration.

#### ...In an Area with High Winds

Securely anchor the outdoor unit down with bolts and a metal frame. Provide a suitable air baffle.

#### ...In a Snowy Area (for Heat Pump-type Systems)

Install the outdoor unit on a raised platform that is higher than drifting snow. Provide snow vents.

## When Connecting Refrigerant Tubing



### WARNING

- When performing piping work do not mix air except for specified refrigerant (R410A) in refrigeration cycle. It causes capacity down, and risk of explosion and injury due to high tension inside the refrigerant cycle.
  - Refrigerant gas leakage may cause fire.
- Ventilate the room well, in the event that is refrigerant gas leaks during the installation. Be careful not to allow contact of the refrigerant gas with a flame as this will cause the generation of poisonous gas.
  - Keep all tubing runs as short as possible.
  - Use the flare method for connecting tubing.
  - Apply refrigerant lubricant to the matching surfaces of the flare and union tubes before connecting them, then tighten the nut with a torque wrench for a leak-free connection.
  - Check carefully for leaks before starting the test run.
  - Do not leak refrigerant while piping work for an installation or re-installation, and while repairing refrigeration parts.  
Handle liquid refrigerant carefully as it may cause frostbite.

## When Servicing

- Turn the power OFF at the main power box (mains) before opening the unit to check or repair electrical parts and wiring. 
- Keep your fingers and clothing away from any moving parts.
- Clean up the site after you finish, remembering to check that no metal scraps or bits of wiring have been left inside the unit being serviced.



### WARNING

- Do not clean inside the indoor and outdoor units by users. Engage authorized dealer or specialist for cleaning.
- In case of malfunction of this appliance, do not repair by yourself. Contact the sales dealer or service dealer for repair.







### CAUTION

- Do not touch the air inlet or the sharp aluminum fins of the outdoor unit. You may get hurt. 
- Ventilate any enclosed areas when installing or testing the refrigeration system. Escaped refrigerant gas, on contact with fire or heat, can produce dangerously toxic gas.
- Confirm after installation that no refrigerant gas is leaking. If the gas comes in contact with a burning stove, gas water heater, electric room heater or other heat source, it can cause the generation of poisonous gas.

## Others



### CAUTION

- Do not touch the air inlet or the sharp aluminum fins of the outdoor unit. You may hurt. 
- Do not sit or step on the unit, you may fall down accidentally. 
- Do not stick any object into the FAN CASE. You may be injured and the unit may be damaged.   

## Check of Density Limit

The room in which the air conditioner is to be installed requires a design that in the event of refrigerant gas leaking out, its density will not exceed a set limit.

The refrigerant (R410A), which is used in the air conditioner, is safe, without the toxicity or combustibility of ammonia, and is not restricted by laws imposed to protect the ozone layer. However, since it contains more than air, it poses the risk of suffocation if its density should rise excessively. Suffocation from leakage of refrigerant is almost non-existent. With the recent increase in the number of high density buildings, however, the installation of multi air conditioner systems is on the increase because of the need for effective use of floor space, individual control, energy conservation by curtailing heat and carrying power, etc.

Most importantly, the multi air conditioner system is able to replenish a large amount of refrigerant compared to conventional individual air conditioners. If a single unit of the multi air conditioner system is to be installed in a small room, select a suitable model and installation procedure so that if the refrigerant accidentally leaks out, its density does not reach the limit (and in the event of an emergency, measures can be made before injury can occur).

In a room where the density may exceed the limit, create an opening with adjacent rooms, or install mechanical ventilation combined with a gas leak detection device. The density is as given below.

### Total amount of refrigerant (kg)

$$\text{Min. volume of the indoor unit installed room (m}^3\text{)} \leq \text{Density limit (kg/m}^3\text{)}$$

The density limit of refrigerant which is used in multi air conditioners is 0.3 kg/m<sup>3</sup> (ISO 5149).

### NOTE

1. If there are 2 or more refrigerating systems in a single refrigerating device, the amount of refrigerant should be as charged in each independent device.

For the amount of charge in this example:

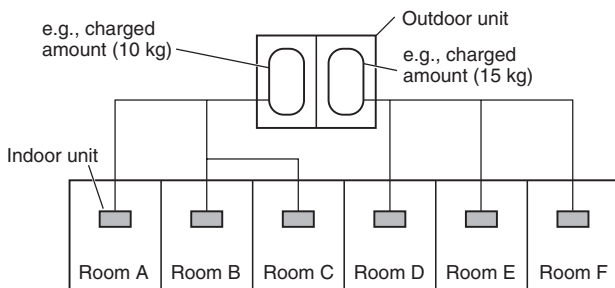

The possible amount of leaked refrigerant gas in rooms A, B and C is 10 kg.

The possible amount of leaked refrigerant gas in rooms D, E and F is 15 kg.



**RoHS**

· This product does not contain any hazardous substances prohibited by the RoHS Directive.



**WARNING**

· You are requested to use RoHS compliant parts for maintenance or repair.

2. The standards for minimum room volume are as follows.

- (1) No partition (shaded portion)

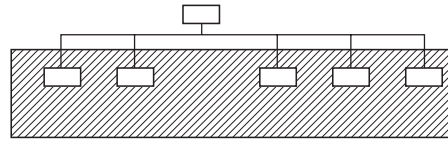

- (2) When there is an effective opening with the adjacent room for ventilation of leaking refrigerant gas (opening without a door, or an opening 0.15% or larger than the respective floor spaces at the top or bottom of the door).

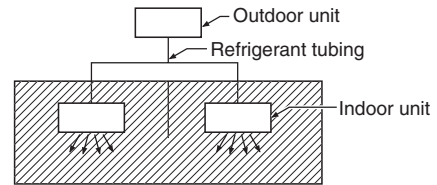

- (3) If an indoor unit is installed in each partitioned room and the refrigerant tubing is interconnected, the smallest room of course becomes the object. But when mechanical ventilation is installed interlocked with a gas leakage detector in the smallest room where the density limit is exceeded, the volume of the next smallest room becomes the object.

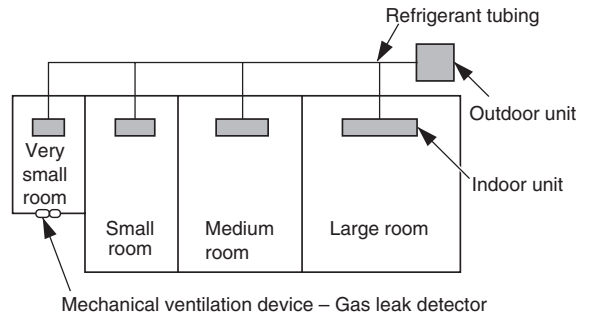

3. The minimum indoor floor space compared with the amount of refrigerant is roughly as follows: (When the ceiling is 2.7 m high)

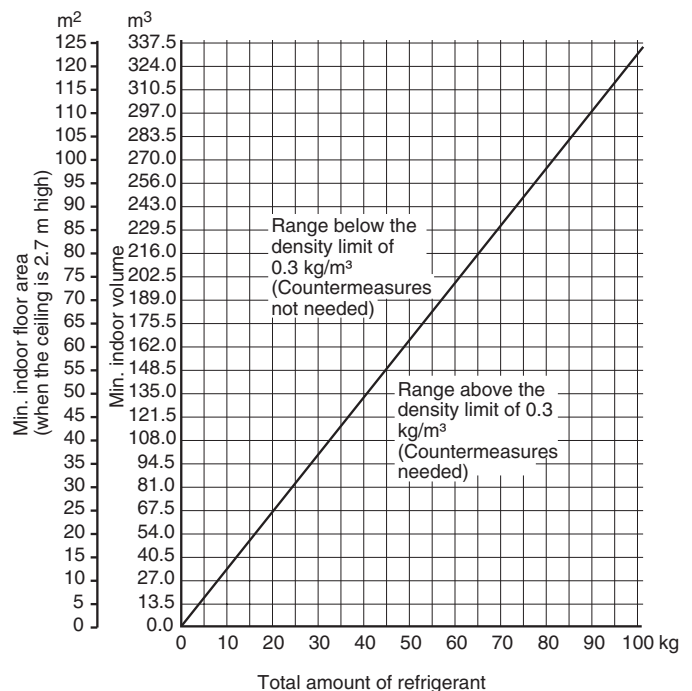



# CONTENTS

<b>Section 1:</b>	<b>CONTROL FUNCTIONS-Outdoor Unit</b>	<b>1-1</b>
1.	Introduction	1-2
2.	Selecting Outdoor Unit for Operation	1-3
3.	Compressor Control	1-4
4.	Output of PCB	1-11
5.	Outdoor Fan Control	1-16
6.	Indoor Units Control from the CCU	1-19
7.	Oil Control	1-22
8.	4-WAY Valve Adjustment Control	1-26
9.	Defrost Control	1-27
10.	Upper Current Limitation Mode	1-31
11.	Alarm Information	1-32
12.	Backup Operation	1-36
13.	Other Functions	1-39
	Detail setting in EEPROM of outdoor unit	1-42
<b>Section 2:</b>	<b>CONTROL FUNCTIONS-Indoor Unit</b>	<b>2-2</b>
1.	Room Temperature Control	2-2
2.	Heating Standby	2-4
3.	Automatic Fan Speed Control	2-5
4.	Indoor Unit MOV Control	2-6
5.	Drain Pump Control	2-6
6.	Automatic Heating/Cooling Control	2-7
7.	Discharge Air Temperature Control	2-8
8.	RAP Valve Kit Control	2-8
9.	Automatic Flap Control	2-9
10.	Filter Sign	2-9
11.	Electric Heater Control	2-10
12.	Fan Control during Dry Mode	2-10
13.	Ventilation Fan Output	2-11
14.	T10 Terminal	2-11
15.	Parameter	2-12
<b>Section 3:</b>	<b>OUTDOOR UNIT REPAIR PROCEDURES</b>	<b>3-2</b>
1.	Removing Panels	3-2
2.	Discharging Compressor Oil	3-3
3.	Backup Operation	3-6
4.	Recovering Refrigerant	3-8
5.	Checking for Leakage After Repair	3-15
6.	Evacuating System	3-17
7.	Charging Compressor Oil	3-19
8.	Pumping Out Refrigerant from Outdoor Unit	3-24
9.	Compressor	3-27

<b>Section 4:</b>	<b>OUTDOOR UNIT MAINTENANCE REMOTE CONTROLLER</b> .....	<b>4-1</b>
	1. Overview .....	4-2
	2. Functions .....	4-3
	3. Ordinary Display Controls and Functions .....	4-4
	4. Monitoring Operations .....	4-9
	5. Outdoor Unit Alarm History Monitor .....	4-11
	6. Mode Settings .....	4-12
<b>Section 5:</b>	<b>REMOTE CONTROLLER FUNCTIONS</b> .....	<b>5-1</b>
	1. Simple Settings Function .....	5-2
	2. Detailed Settings Function .....	5-4
	3. Remote Controller Servicing Functions .....	5-17
<b>Section 6:</b>	<b>TROUBLE DIAGNOSIS</b> .....	<b>6-1</b>
	1. Contents of Remote Controller Switch Alarm Display .....	6-2
	2. Outdoor Unit Control Panel LED Display .....	6-4
	3. Remote Controller Servicing Functions .....	6-5
	4. 2WAY SYSTEM Alarm Codes .....	6-7
	5. Blinking Inspection Display on the Remote Controller .....	6-28
	6. Inspection of Parts .....	6-30
	7. Test Pin .....	6-31



## 1. CONTROL FUNCTIONS-Outdoor Unit

1. Introduction . . . . .	1-2
2. Selecting Outdoor Unit for Operation . . . . .	1-3
3. Compressor Control . . . . .	1-4
4. Output of PCB . . . . .	1-11
5. Outdoor Fan Control . . . . .	1-16
6. Indoor Units Control from the CCU . . . . .	1-19
7. Oil Control . . . . .	1-22
8. 4-WAY Valve Adjustment Control . . . . .	1-26
9. Defrost Control . . . . .	1-27
10. Upper Current Limitation Mode . . . . .	1-31
11. Alarm Information . . . . .	1-32
12. Backup Operation . . . . .	1-36
13. Other Functions. . . . .	1-39
Detail setting in EEPROM of outdoor unit. . . . .	1-42

# 1. Introduction

The 2WAY system allows multiple outdoor units to be connected.

-This system can be expanded to connect a maximum of 3 outdoor units.

-The maximum system capacity is 60HP(at the Standard-COP mode).

## PCB setting of outdoor unit

All the outdoor units contain inverter compressors. The main and the sub units have to be set on the PCB of each outdoor unit.

-Main outdoor unit

The outdoor unit where the unit No. is set to "1" activates the CCU (command controller unit) functions that controls the entire system. This outdoor unit is main outdoor unit.

For the main outdoor unit, perform all the settings in the table below.

-Sub outdoor unit

The outdoor unit where the unit No. is set to other than "1" is a sub outdoor unit.

The system will not operate if no outdoor unit has been set as unit No. "1."

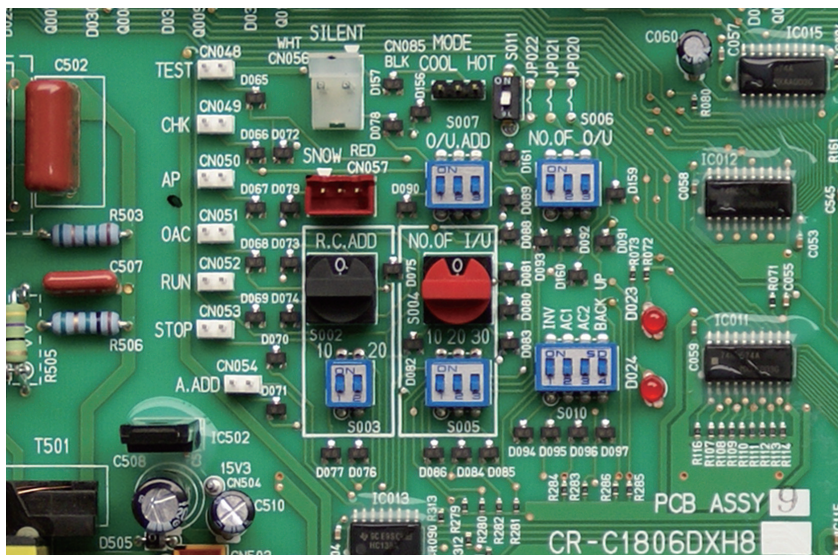

## Required settings

	Factory preset mode	Main outdoor unit On-site setting	Sub outdoor unit On-site setting
System address	1	System 1 ~ 30	Not necessary
No. of indoor units	1	1 ~ 64 units	Not necessary
No. of outdoor units	1	1 ~ 3 units	Not necessary
Unit No.	1	Unit No. 1	Unit Nos. 2 ~ 3

The CCU functions are disabled at sub units. Therefore no problems will result even if the system address, No. of indoor units, and No. of outdoor units settings are made at the sub units.

## 2-1. Outdoor Unit Operating Rules

All outdoor units in this system contain an inverter compressor. Therefore there is no order of priority for the outdoor units.

## 2-2. Delayed Start of Outdoor Units

### 2-2-1. Delayed start of outdoor units in the same system

If it is necessary to operate the compressors simultaneously at multiple outdoor units, each outdoor unit will start in order of unit No. every one second, beginning with unit No. 1.

This is in order to reduce the load on the power supply equipment.

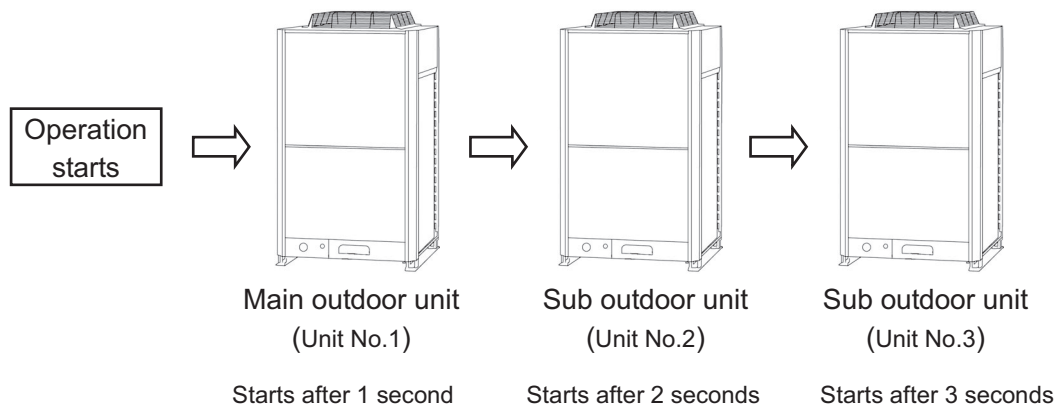

### 2-2-2. Delayed start for each system

When systems are linked with one communication cable and multiple systems are required to operate simultaneously by the central control device, all main outdoor units will begin operating simultaneously. In this situation, the load of the power supply equipment increases temporarily.

To prevent the overload, the start timing of each system can be delayed.

In order to enable this delay time, it must be set in the EEPROM for each system (Main outdoor unit). Those systems (Main outdoor units) where this setting has been made will start after a delay according to their system addresses.

To activate this delay start function, it is necessary to set it to EEPROM on main outdoor PCB.

EEPROM setting in main outdoor unit

CODE: 3E

Setting No	Delay time
0	Delay start invalid (factory preset mode)
1	[System address * 8] seconds delay
2	[System address * 8] seconds delay
3	[System address * 8] seconds delay

\* Delayed start for each system is not set in the factory preset mode.

## 2-3. Outdoor Unit Stop Rules

### 2-3-1. Stopping of all outdoor units

When all outdoor units must stop, the units stop at the same time. However, depending on the communications timing, a difference of approximately 10 seconds may occur.

### 2-3-2. Stopping of individual outdoor units according to load of air-conditioning

-In cooling mode, all inverter compressors in the outdoor units operate and stop simultaneously.

\* When ambient temperature is 10°C or more, inverter compressor may stop excluding one with short operating time.

-In heating mode, the outdoor unit which has the inverter compressor with the shortest amount of operating time continues to run and rest of the other outdoor units may be stopped according to load of air-conditioning.



# 3. Compressor Control

## 3-1. Compressors Mounted in the Outdoor Units

Outdoor unit Capacity			8 HP	10 HP	12 HP	14 HP	16 HP	18 HP	20 HP
Installed compressor	Compressor 1	DC Inverter Rotary	10 HP	6 HP	6 HP	10 HP	10 HP	10 HP	10 HP
	Compressor 2	Constant speed Scroll	—	5 HP	6 HP	5 HP	6 HP	5 HP	6 HP
	Compressor 3	Constant speed Scroll	—	—	—	—	—	5 HP	6 HP

Top view

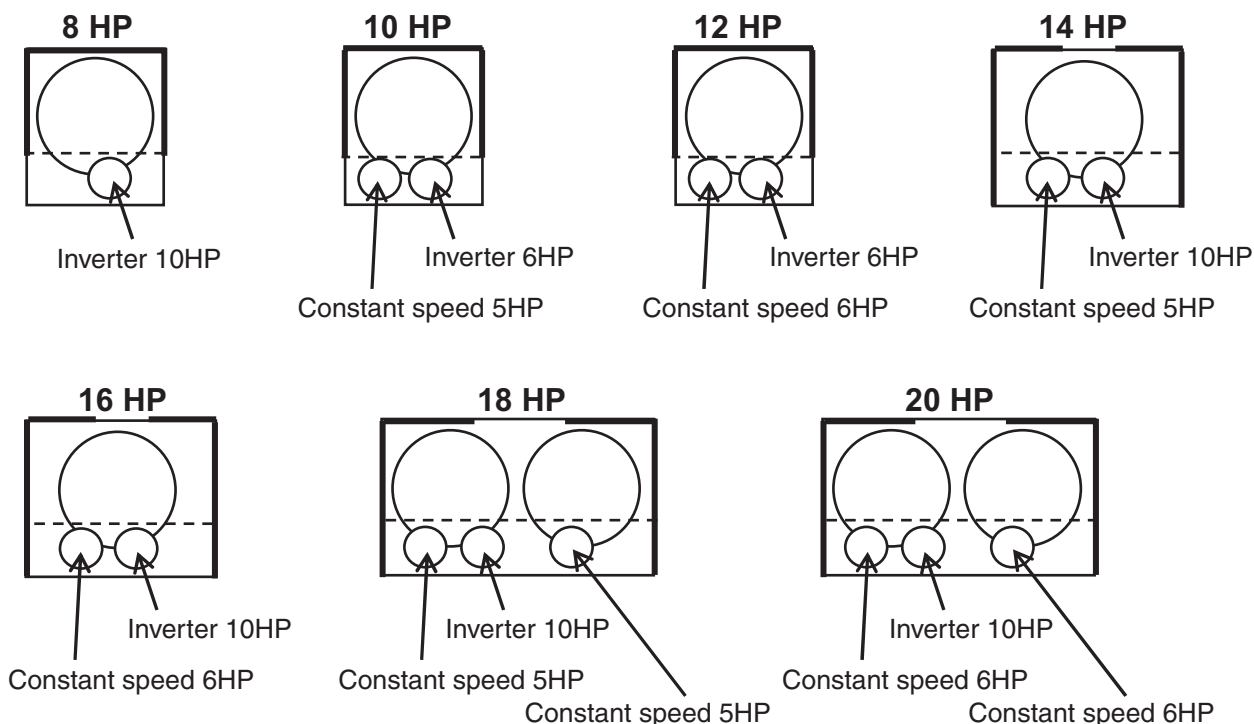

## 3-2. Compressor Selection Rules

### 3-2-1. Priority order of inverter compressor and constant speed compressor

Priority order of inverter compressor is higher than that of constant speed compressor.

\* However, when the inverter compressor stops because of protection control or forced stop etc., a constant speed compressor operates while the inverter compressor has stopped.

### 3-2-2. Priority order of inverter compressors

The priority order of the inverter compressor with the least operating time is high.

\* The comparison is made among inverter compressors other than ones stopped because of protection control or forced stop.

### 3-2-3. Priority order of constant speed compressors

The priority order of Compressor 2 is higher than that of Compressor 3.

### 3-2-4. Priority order between Compressors 2, priority order between Compressors 3

Priority order of Compressor 2 and Compressor 3 with the least operating time is high.

\* The comparison is made among constant speed compressors other than ones stopped because of protection control or forced stop.

### 3. Compressor Control

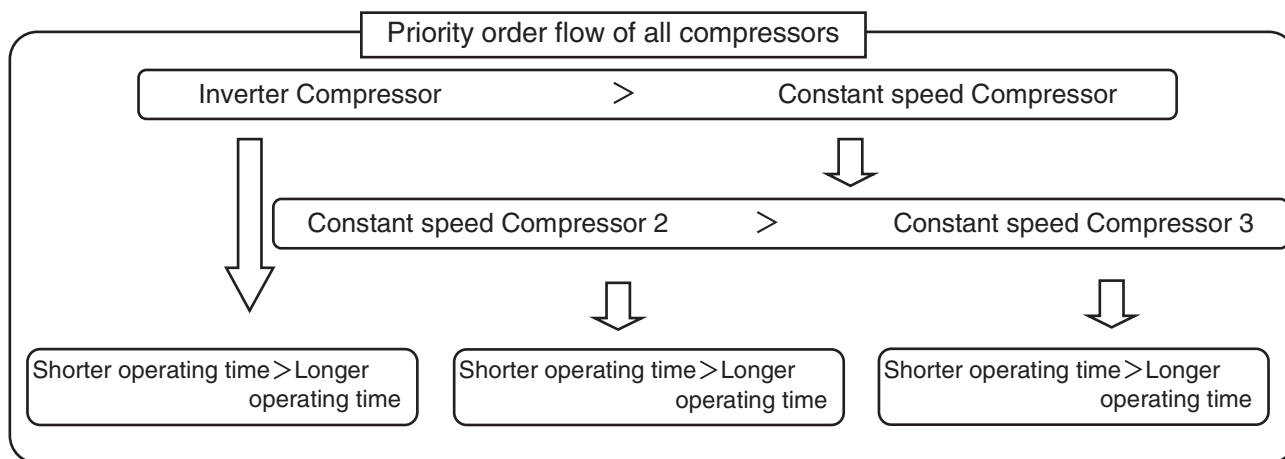

#### 3-2-5. Operating compressors

##### -Cooling operation

All the inverter compressors operate when the system starts.

The constant speed compressors operate according to those priority orders when the load of air conditioner becomes large.

\*Some inverter compressors might stop after the system starts when the load of the air conditioner is very small and ambient temperature is 10°C or more.

##### -Heating operation

At least, one inverter compressor operates when the system starts.

The other compressors operate according to those priority orders when the load of air conditioner becomes large.

#### 3-2-6. stopping compressors

##### -Situation in which multiple compressors stop

All compressors stop at the same time when all indoor units stop or defrosting operation is done.

\*The stop of the compressor might shift for about ten seconds by the time lag of the communication between outdoor units.

##### -Situation in which compressors stop in order of priority

The compressor with lower priority order stops when the load of air-conditioning decreases.

\*The last compressor to stop operating is the inverter with the shortest amount of operating time.

### 3-3. Delay start of each compressor

To decrease the load of power-supply facility, it is possible to delay the start timing of each compressor.

#### 3-3-1. Delay start of compressor in the same system

When the inverter compressor and the constant speed compressor start at the same time, the inverter starts first, and the constant speed starts at least five seconds later.

\*Depending on the operation states, the constant speed compressor might not start for 60 seconds after the inverter compressor starts.

Multiple constant speed compressors start every second.

## 3. Compressor Control

### 3-4. Operating frequency range of inverter compressor

- When one of the constant speed compressor mounted in the outdoor unit do not operate:

The inverter compressor can operate between 25Hz and 100Hz.

- When all constant speed compressors mounted in the outdoor unit operate:

The inverter compressor can operate within the range in the table below.

Outdoor Unit Capacity	8HP	10HP	12HP	14HP	16HP	18HP	20HP
Min.frequency	25						
Max.frequency	79.5	66.0	81.0	88.5	94.0	62.5	87.0

[Hz]

- \*The inverter frequency during operation may be lower than the frequency listed above due to overload current protection control.

### 3-5. Forced Compressor Stop

Once a compressor stops, it will not start for a period of 3 minutes (3-minute forced OFF). However, this does not apply when the compressor was forced to stop as the result of a control operation during the special controls (start control, defrost control, refrigerant oil recovery control, etc.)

### 3-6. Capacity Control (Roadmap control)

The capacity control by the compressors is performed according to the pressure sensor attached to the outdoor unit and temperature thermistor attached to the indoor / outdoor unit heat exchanger.

- \* With roadmap control, the pressure detected by the pressure sensor is converted to saturation temperature before it is used by microcomputer. This converted temperature is called "pressure sensor temperature".

This control is performed every 30 seconds.

- Required level of each indoor unit

Required level of indoor unit is calculated by difference between preset temperature in remote controller and intake temperature of indoor unit (that is called "DTi"), difference between preset discharge air temperature in EEPROM on indoor unit PCB and discharge air temperature of indoor unit (that is called "DTo").

Required level has "0" to "30" phases. This level becomes "31" at the test run.

The target temperature of indoor unit heat exchanger is decided according to the maximum required level.

- \*Target temperature of all indoor units heat exchanger is same value because all indoor units are connected with same pressure piping.

- Definition of evaporation temperature and condensation temperature

Evaporation temperature (Te): The lowest temperature of heat exchangers (E1, E3) in all indoor units including stopped indoor units.

Condensation temperature (Tc): This depends on the operating mode.

Cooling mode: The highest temperature of high pressure sensor temperature in outdoor units and the outdoor unit heat exchanger liquid temperatures.

Heating mode: The highest temperature of high pressure sensor temperature in outdoor units and the indoor unit heat exchanger liquid temperatures (E1).

- \* The E3 in indoor heat exchanger may indicate superheated gas temperature. Therefore it is not included for detection of Tc.

#### 3-6-1. Evaporation temperature adjustment by roadmap control

The cooling capacity is adjusted with this control. It prevents freezing of the indoor unit's heat exchanger and the dew to the outside panel of the indoor unit. The capacity is adjusted according to the following figure.

Evaporation temperature area

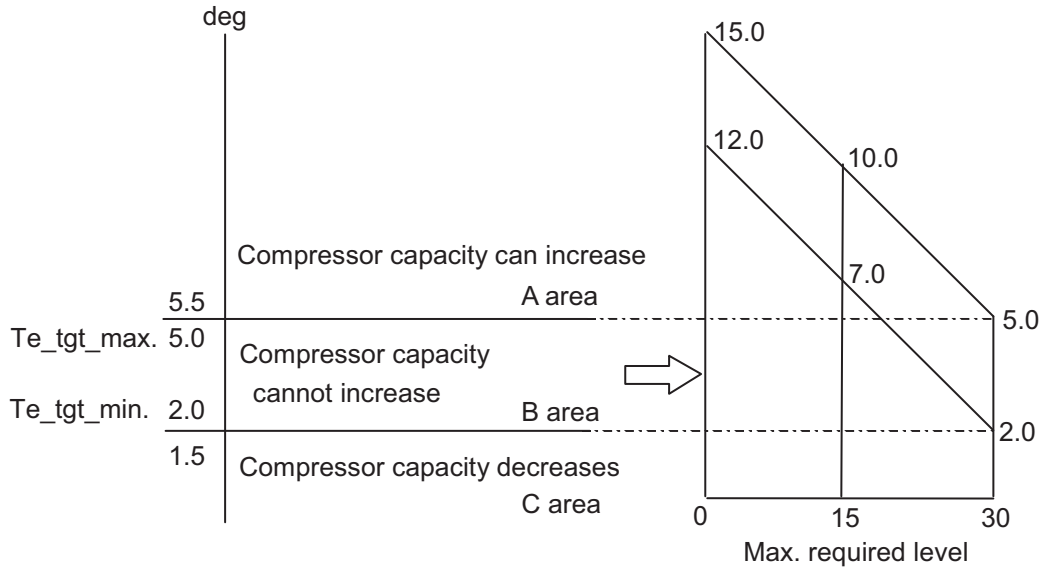

- \*The evaporation temperature area changes depending on the maximum required level of each indoor unit as shown in the right figure.
- \*C area is regarded as B area for 6 minutes after compressor starts.
- \*When the system operates in a minimum capacity, the system will continue operating for at least 6 minutes if the evaporation temperature area is C area.
- \*The evaporation temperature is not adjusted while specially controlling defrosting and the oil recovery, etc.
- \*The evaporation temperature is not adjusted when there are one or more indoor units that select the test run. If one or more indoor units are selected into test run, the system doesn't stop in all states except alarm appearing.
- \*The test run will finish automatically in about one hour.

Area shift function

B area is able to shift by EEPROM setting of outdoor unit.  
EEPROM setting in main outdoor unit

Lower temperature of B area  
= 2.0 + Te<sub>L</sub>

CODE: 3F

Setting No	Te <sub>L</sub> (deg)
-9	-9
-8	-8
⋮	Interval of "1"
-1	-1
0 (factory preset mode)	0
1	1
⋮	⋮
9	9

C area shifts according to changed Te<sub>L</sub>

Lower temperature of B area  
= 5.0 + Te<sub>U</sub>

CODE: 40

Setting No	Te <sub>U</sub> (deg)
-9	-9
-8	-8
⋮	Interval of "1"
-1	-1
0 (factory preset mode)	0
1	1
⋮	⋮
9	9

A area shifts according to changed Te<sub>H</sub>

## 3-6-2. Condensation temperature adjustment by roadmap control

Target temperature of the B area is different between cooling and heating operation.

	Target lower temperature (Tc_tgt_min)	Target upper temperature (Tc_tgt_max)
Cooling	53.0°C	55.0°C
Heating	48.0°C	51.0°C

### -Cooling operation

The purpose of this control at cooling is to prevent abnormal high-pressure.

Condensation temperature area at cooling operation

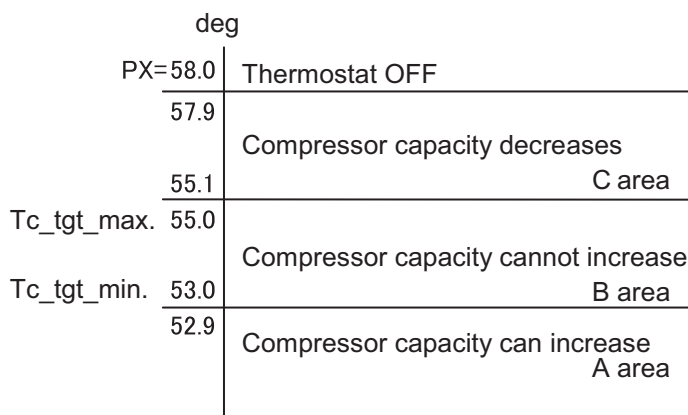

### - Heating operation

The heating capacity is adjusted with this control. It also prevents abnormal high-pressure.

Condensation temperature area at heating operation

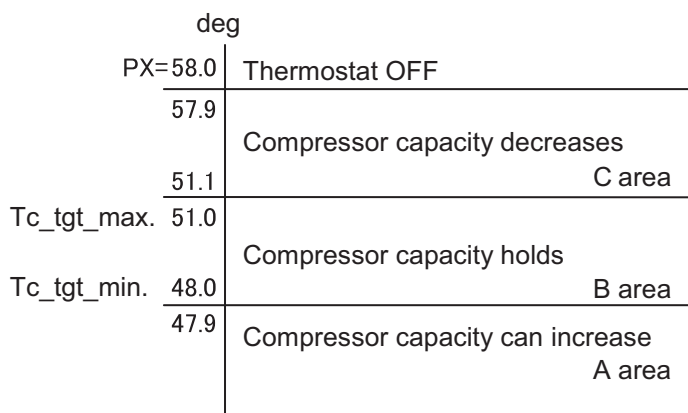

\*PX is usually fixed to 58deg. If the high pressure goes up rapidly after the compressor starts, the system experiences urgent stop. The next time the system will start with lower PX.

\*In the B area, the compressor capacity changes depending on the refrigerant condition.

\*When the system operates in a minimum capacity, the system will continue operating for at least 6 minutes if the condensation temperature area is C area.

\*The condensation temperature is not adjusted when there are one or more indoor units that select the test run.

### 3. Compressor Control

#### Area shift function

B area is able to shift by EEPROM setting of outdoor unit.

EEPROM setting in main outdoor unit

Lower temperature of B area

$$= Tc\_tgt\_min + Te\_L$$

CODE: 35

Setting No	Tc_L (deg)
-7	-7
-6	-6
⋮	Interval of "1"
-1	-1
0 (factory preset mode)	0
1	1
⋮	⋮
7	7

A area shifts according to changed Tc\_L

Lower temperature of B area

$$= Tc\_tgt\_max + Te\_U$$

CODE: 36

Setting No	Tc_U (deg)
-7	-7
-6	-6
⋮	Interval of "1"
-1	-1
0 (factory preset mode)	0
1	1
⋮	⋮
7	7

C area shifts according to changed Tc\_U

#### Limit pressure adjustment function

Operation pressure is able to be adjusted for existing old piping.

If area shift function is set, values below shift.

EEPROM setting in main outdoor unit

CODE: 4B

Setting No	Limited pressure (Reference)	PX(°C)	Cooling mode		Heating mode	
			Tc_tgt_min	Tc_tgt_max	Tc_tgt_min	Tc_tgt_max
0	3.3 MPa	52.5	47.0	49.0	47.0	48.0
1	3.6 MPa	56.0	51.0	53.0	48.0	51.0
2 (factory preset mode)	3.8 MPa	58.0	53.0	55.0	48.0	51.0
3	No use					

### 3-7. Protection control

#### 3-7-1. Compressor discharge temperature protection

The compressor capacity is controlled according to the table below.

\*Discharge temperature that is used for this control is the highest temperature among all compressors.

106 deg	Stop	If this temperature is detected at regular intervals, alarm appears.
105 deg	Compressor capacity decreases	Capacity goes down 2.0 HP
104 deg		Capacity goes down 1.0 HP
103 deg		Capacity goes down 0.5 HP
101 deg		Compressor capacity cannot increase
		Compressor capacity can increase



### 3. Compressor Control

#### 3-7-2. Overcurrent protection of compressor

Current limitation of compressor is shown in the table below. This limitation is to protect the compressor, so that the current of the power cable connected with the compressor is limited.

\* For the inverter compressor, this is the secondary current from HIC board.

	Inverter 6 HP	Inverter 10 HP	Constant speed 5 HP	Constant speed 6HP
Limit current 2	18.0	21.0	13.6	16.4
Max. current 2 H	15.5	18.5	-	-
Max. current 2 L	14.5	17.5	-	-

Limit current 2	Stop If this current is detected at regular intervals, alarm appears.
Max. current 2 L	Inverter compressor Hz goes down
Max. current 2 H	Inverter compressor Hz cannot increase
Max. current 2 H	Inverter compressor Hz can increase

#### 3-7-3. Primary current protection of HIC board

The fan motor current is included in primary current. PCB is protected from the power consumption increase of fan motor when the heat exchanger is blocked by frost etc.

	Inverter 6 HP	Inverter 10 HP
Limit current 1	18.0	21A
Max. current 1 H	15.0	18A
Max. current 1 L	14.0	17A

Limit current 1	Stop If this current is detected at regular intervals, alarm appears.
Max. current 1 H	Inverter compressor Hz goes down
Max. current 1 L	Inverter compressor Hz cannot increase
Max. current 1 L	Inverter compressor Hz can increase

\*When restarting after stopping by protection control, the compressor capacity will increase slowly.

Reference Inverter layout sketch

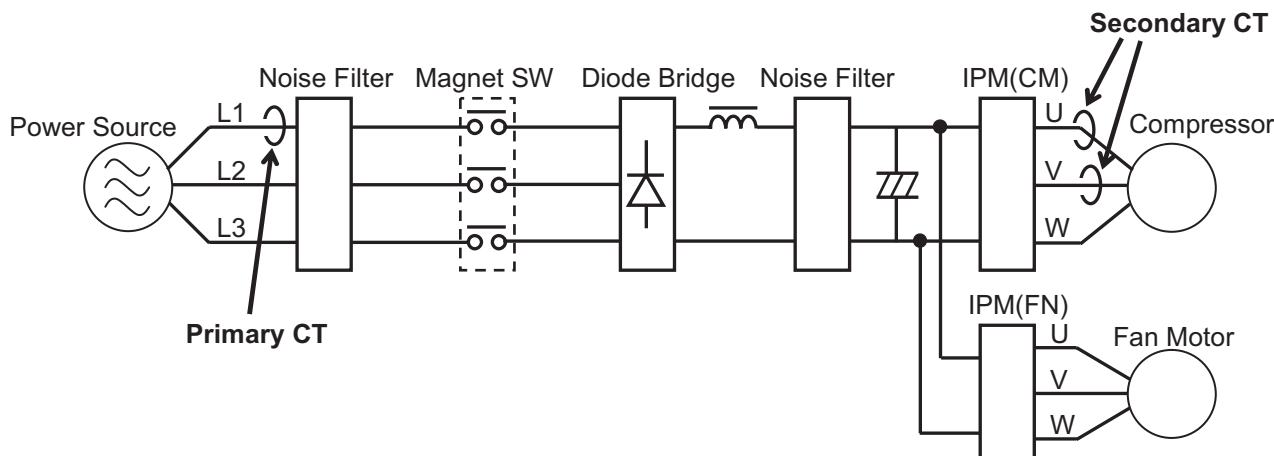



Item	Remarks	Indication on PCB
Electromagnetic valve	4 way valve	20S
	Save valve	SAVE
	Refrigerant control valve	RCV
	Refrigerant balance valve	RBV
	Oil recovery valve	ORVR
	By-pass valve for oil flushing	BPV
	Refrigerant interception valve	O2
Motor Operated Valve	MOV for heat exchanger 1	MOV1
	MOV for heat exchanger 2	MOV2
	MOV for Sub cooler	MOV4
Crankcase heater	Crankcase heater for inverter	CH1
	Crankcase heater for constant speed 1	CH2
	Crankcase heater for constant speed 2	CH3

### 4-1. 4 way valve [20S]

- This valve turns OFF at cooling, and turns ON at heating operation.
- This valve turns OFF at defrosting.
- \* When the outdoor unit stops, the 4-way valve maintains the same state just before. However, when the system stopped condition continues for 30 minutes, it is turned OFF.

### 4-2. SAVE valve [SAVE]

- This valve turns ON 5 seconds before the inverter compressor starts. After the inverter compressor starts, the valve is ON for ten seconds. After that, it turns OFF.

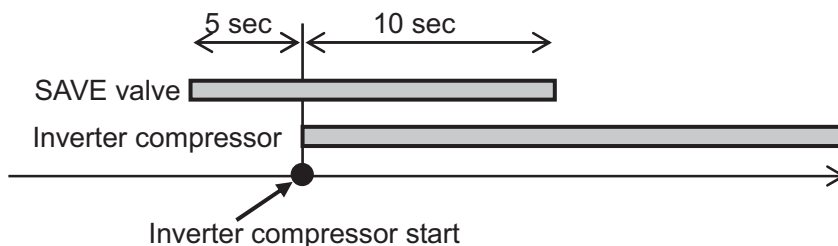

- This valve turns ON for 30 seconds after the outdoor unit stops. After that, it turns OFF.
- This valve turns ON when high pressure sensor detects 3.4MPa to prevent abnormal pressure. This valve turns OFF when the high pressure goes down below 3.3MPa.

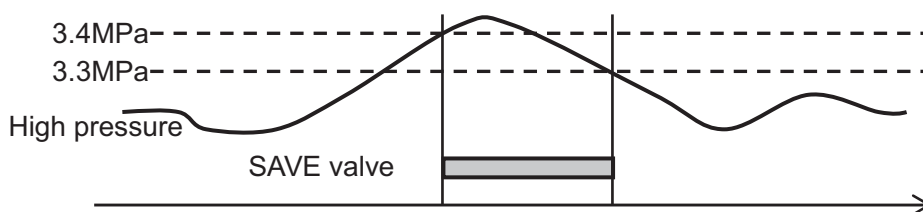

- This valve might turn ON when the system capacity is excessive although the inverter compressor operates at 25Hz.

## 4. Output of PCB

### 4-3. Refrigerant control valve [RCV]

The main purpose of this valve is to adjust the flow of refrigerant (refrigerant volume) on the evaporator. When the valve determines that there are signs of a low refrigerant volume, refrigerant is supplied from the receiver tank to the system.

- This valve turns ON when the evaporator is refrigerant shortage.
  - The heat exchanger of indoor unit is evaporator in cooling operation.
  - The heat exchanger of outdoor unit is evaporator in heating operation.
- This valve turns OFF when the excessive refrigerant is in the condenser.
  - The heat exchanger of indoor unit is condenser in heating operation.
  - The heat exchanger of outdoor unit is condenser in cooling operation.
- This valve turns OFF when the outdoor unit is stopped.
- This valve might turn ON when special control is in progress.

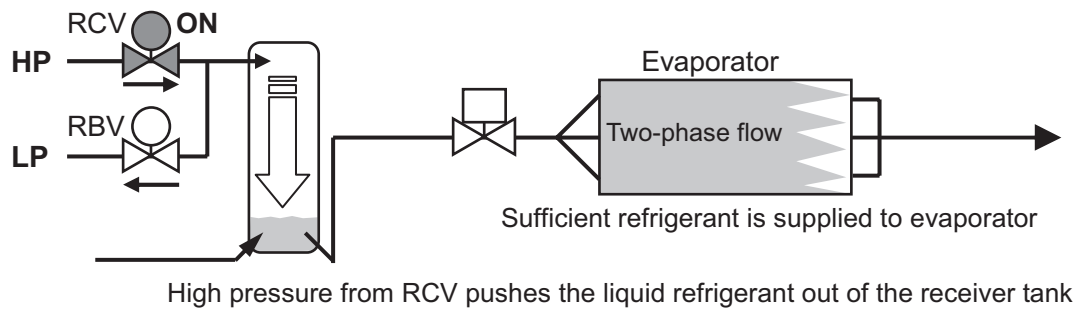
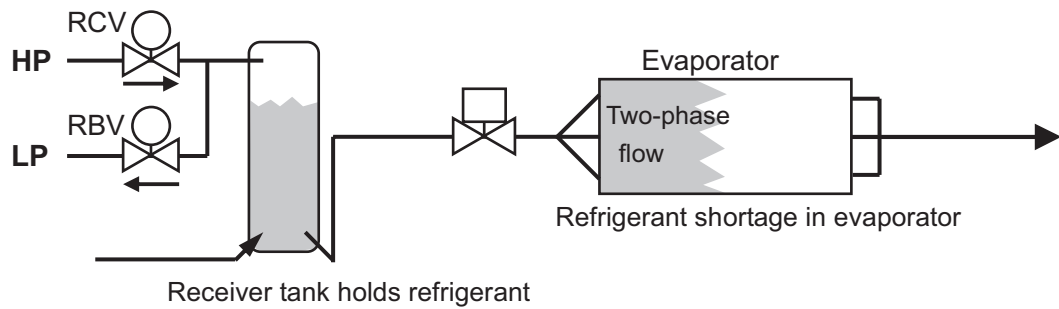

## 4. Output of PCB

### 4-4. Refrigerant balance valve [RBV]

The main purpose of this valve is to adjust the flow of refrigerant (refrigerant volume) in the indoor unit heat exchanger at heating operation. When the valve determines that there are signs of excess refrigerant, refrigerant is recovered at the receiver tank.

This valve also turns ON in order to recover refrigerant at the outdoor unit after heating operation is stopped.

\* This valve is never turned ON at the same time with the RCV.

- This valve turns ON for 20 seconds after the system stops at heating mode, and then turns OFF.
- This valve turns ON once after the system starts at heating mode.
- This valve turns OFF when an abnormal drop in compressor discharge gas temperature is detected.
- This valve turns OFF when liquid back to the compressor is occurring.

Judgment of liquid back :     Detected suction temperature is lower than low-pressure sensor temperature.  
   Difference between high-pressure sensor temperature and discharge temperature  
   of compressor is small. (less than 10 deg)

\* After the valve turns from ON to OFF, it will not turn ON again for 15 minutes.

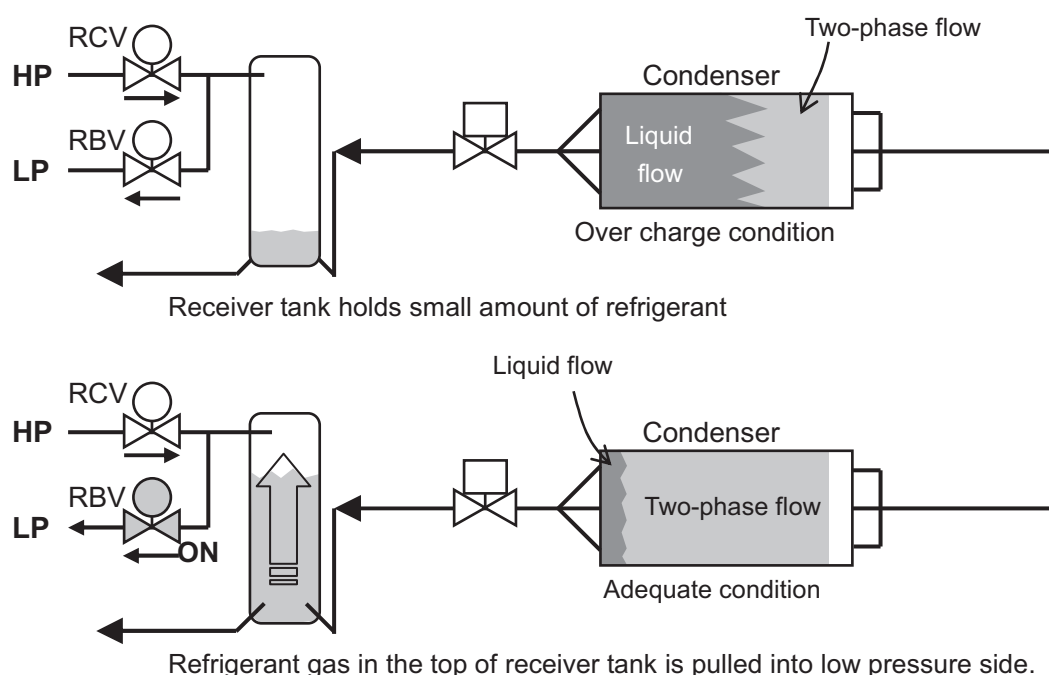

### 4-5. Oil recovery valve [ORVR]

This valve is for recovering oil from the oil separator of its own outdoor unit or balance tube to the compressor of its own outdoor unit.

- This valve turns ON when the oil level of the compressor is "0" or "1"  
 In this situation, system performs Self oil recovery control, Inter-outdoor unit oil recovery control, or system oil recovery control.
- This valve turns ON for 2 minutes after the compressor starts.
- This valve is always OFF when outdoor unit is stopped
- \* For oil level of compressor, refer to "Oil Control" section.

### 4-6. By-pass valve [BPV]

This valve is for pushing the oil in the balance piping into other outdoor unit.

- This valve turns ON when the oil level of compressor is "2" or "1" in its own outdoor unit and the oil level of compressor is "0" in other outdoor unit.
- \* This valve turns ON for ten seconds and turns OFF for 20 seconds. This operation is repeated while oil is supplied to others.
- \* For more information on oil level of compressor, refer to "Oil Control" section.

## 4. Output of PCB

### 4-7. Refrigerant interception valve [O2]

This valve works when the outdoor unit receives signal of the refrigerant leakage from the indoor unit. The indoor unit that transmits the signal of the refrigerant leakage gives "P14"alarm.

To activate this function, it is necessary to set it to EEPROM on the main outdoor PCB and indoor PCB.

EEPROM setting in main outdoor unit

CODE: C1

Setting No	
0	This function invalid (factory preset mode)
1	This valve is turned OFF when the system is normal. This valve is turned ON when the outdoor unit receives signal from the indoor unit
2	This valve is turned ON when the system is normal. This valve is turned OFF when the outdoor unit receives signal from the indoor unit

EEPROM setting in indoor unit

CODE: 0B

Setting No	Function of EXCT plug short-circuit
0	Indoor unit does thermostat OFF (factory preset mode)
1	Indoor unit gives "P14"alarm and transmits the refrigerant leakage signal.

### 4-8. MOV for heat exchanger [MOV1, MOV2]

#### 4-8-1. Type of Motor Operated Valves

Outdoor unit Capacity	8HP	10HP	12HP	14HP	16HP	18HP	20HP
MOV1	For heat exchanger in upper row			For left side heat exchanger			
MOV2	For heat exchanger in lower row			For right side heat exchanger			

#### 4-8-2. Power Initialization

If no indoor units have started (even once) after the power supply to the outdoor unit, the MOV for heat exchanger holds the pulse at 480 pulses.

#### 4-8-3. Operation of MOV for heat exchanger

MOV operation according to the mode.

Mode of system	Cooling			Heating	
	Stop	Stop	Operation	Stop	Operation
MOV 1 (pulse)	0	0	480	0	25 - 480
MOV 2 (pulse)	0	0	480	0	25 - 480

\*If any one compressor in the outdoor unit is operating at heating mode, both MOVs perform SH control of heat exchanger.

SH control adjusts the difference between the liquid temperature and gas temperature to 1 - 5 deg.

#### 4-8-4. Minimum MOV pulse adjustment function in heating operation

Minimum pulse which is set to 25 at the factory is able to adjust (shift).

Minimum pulse under SH control = 25 + XX

EEPROM setting in each outdoor unit

CODE: BA (for MOV1),

BB (for MOV2)

Setting No	XX
-20	-20
-19	-19
⋮	Interval of "1"
0	0 (factory preset mode)
⋮	⋮
30	30

## 4-9. SC Circuit Electronic Control Valve [MOV4]

### 4-9-1. SC Control (Cooling Mode only)

During cooling operation, the liquid refrigerant which condenses at the outdoor unit heat exchanger flows into the receiver tank, and SC (sub-cool = supercooling) approaches 0°C. When SC is small and the length of the tubing connecting the indoor and outdoor units is long, the refrigerant flow in the indoor unit will be reduced significantly. To prevent this trouble from occurring, MOV4 operates so as to increase supercooling in the double tube coil near the outlet of the outdoor unit.

In addition, MOV4 controls refrigerant flow volume so that it will not flow back to the compressor in the liquid state. SH in suction that is difference between the suction temperature and low pressure sensor temperature is adjusted to 5-20°C.

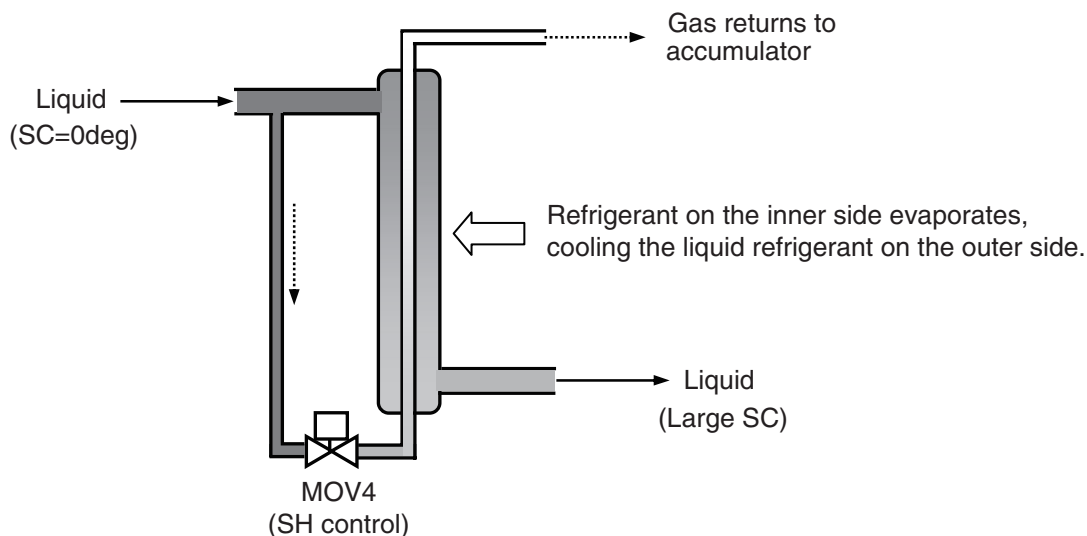

### 4-9-2. Discharge temperature control of compressor

When the discharge temperature increases to 95°C or more, MOV 4 opens to 100 pulses to cool down the compressor. MOV 4 operates according to the state of the discharge temperature between 20 - 480 pulses. This operation takes priority over SC control.

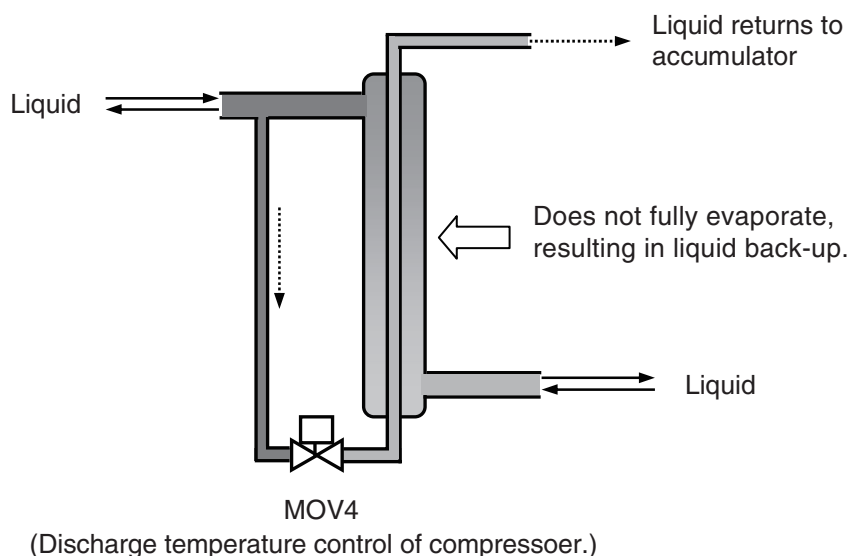

This operation is continued until discharge temperature decreases to 80°C or less.

## 4-10. Crankcase heater control [CH1, CH2, CH3]

When the compressor stops, the crankcase heater of its own compressor is turned ON.



## 5. Outdoor Fan Controls

### 5-1. No. of fan motor

Outdoor unit Capacity	8HP	10HP	12HP	14HP	16HP	18HP	20HP
No. of Fan Motor	1	1	1	1	1	2	2

### 5-2. Fan mode

These outdoor units utilize a DC fan motor that can be controlled in a maximum of 15 steps (15 modes). Fan modes 15 can only be used if high static-pressure mode has been set.

### 5-3. Outdoor Fan Min. Fan Mode and Max. Fan Mode

	Min. fan mode	Max. fan mode
Cooling operation	Outdoor air temp. > 15°C: 1 Outdoor air temp. ≤ 15°C: 0	14
Heating operation	1	14

\* Even if the fan mode is "0" during cooling operation, the fan mode may change to "1" every XX minutes for cooling the inverter HIC.

EEPROM setting in each outdoor unit

CODE: A5

Setting No	
0	0
1	1
2	2
⋮	Interval of "1"
5	5 (factory preset mode)
⋮	⋮
9	9

### 5-4. Fixed Initial Fan Mode

For the first 30 seconds after operation starts, the mode is fixed at the initial mode which was calculated from the relationship between the outdoor air temperature and the outdoor unit horsepower.

If the outdoor unit horsepower (compressor capacity) changes dramatically, the initial mode may be recalculated and may be again fixed for 30 seconds.

### 5-5. Operation after Fixed Initial Fan Mode

After the fixed initial fan mode, the fan mode is increased or decreased according to the operating conditions.

#### 5-5-1. Cooling operation

(A) Fan mode is increased when the detected high pressure sensor temperature is high, and is decreased when the pressure sensor temperature is low.

\* The fan mode is always increased when the detected high pressure sensor temperature is 46°C or higher.

(B) The fan mode may be decreased when the system detects refrigerant shortage at an indoor unit.

(C) If the fan mode becomes 0 during cooling operation and this condition lasts for 5 minutes, the fan mode is changed to 1.

#### 5-5-2. When all indoor units are operating in heating mode

(A) If the condensation temperature is low, the fan mode is increased at regular intervals.

(B) If the condensation temperature is high, the fan mode is decreased in order to prevent excessive loads.

(C) The fan mode may be increased when the outdoor liquid temperature drops to 7°C or below.

## 5. Outdoor Fan Controls

### 5-6. Silent Mode

This unit includes 2 types of silent modes.

Max. fan mode in silent mode

Outdoor unit cacacity	-3dB mode	-5dB mode
8 HP	11	8
10 HP	11	10
12 HP	10	9
14 HP	9	8
16 HP	9	8
18 HP	11	10
20 HP	11	10

Selecting the silent mode results in operation that gives priority to reducing noise, because these modes involve restrictions on outdoor unit fan modes, the capacity will be somewhat reduced.

\* The compressor capacity (frequency) is not limited. However, the capacity of the compressor decreases by road map control because of the pressure caused by the decreased fan rotational speed.

\* To activate this function, it is necessary to set it to each outdoor unit.

CODE: 05

Setting No	Silent mode	External input to PCB	Max. effect	Capacity reduction
0	Invalidity (Factory preset mode)	-	-	-
1	Silent is given priority	Necessary	-3dB	Approx -1 HP
2			-5dB	Approx -2 HP
3		Unnecessary	-3dB	Approx -1 HP
4			-5dB	Approx -2 HP
5	Capacity is given priority	Necessary	-3dB	Max. -1 HP
6			-5dB	Max. -2 HP
7		Unnecessary	-3dB	Max. -1 HP
8			-5dB	Max. -2 HP
9	Controlled in moderation	Necessary	-3dB	Max. -1 HP
10			-5dB	Max. -2 HP
11		Unnecessary	-3dB	Max. -1 HP
12			-5dB	Max. -2 HP

\* When the setting is "external input to PCB necessary", this function works by short circuiting "SILENT" pins.

\* When the setting is "external input to PCB unnecessary", this function always works.

\* When the setting is "Capacity is given priority", this function works excluding the following conditions.

Condition that silent mode interrupts

Cooling operation: Ambient temperature  $\geq 38^{\circ}\text{C}$

Heating operation: Ambient temperature  $\leq 2^{\circ}\text{C}$

This function will be useful for nighttime in summer.

\* When the setting is "Controlled in moderation", max. fan mode is decided in the following formula.

Max. fan mode =  $14 - (35 - \text{Ambient temperature}) / 2$

However, minimum fan mode is "6", maximum is "14". (When high static pressure mode, max is "15")

### 5-7. High Static Pressure Mode

The outdoor unit allows a high static pressure changing the settings.

The maximum permissible static pressure is 8 mmAq.

EEPROM setting in each outdoor unit

CODE: 8F

Setting No	
0	Invalid (Factory preset mode)
1	High static pressure mode
2 - 6	No use (Never use)

# 5. Outdoor Fan Controls

## 5-8. Snow Removal Control

### 5-8-1. Independent control of outdoor unit

This control is intended to prevent snow from accumulating on stopped fans.

Fan motor works at 500rpm in the below conditions even if the outdoor unit stops.

- Fan motor operates for 45 seconds and stops for 2 hours when ambient temperature is 5.1°C or more.
- Fan motor operates for 45 seconds and stops for 1.5 hours when ambient temperature is 1.1 - 5.0°C.
- Fan motor operates for 45 seconds and stops for 1 hour when ambient temperature is 1.0°C or less.

### 5-8-2. Control with snow detection sensor (Field supply)

If a snow detection sensor (field supply) is available, the snowfall-protection hood might be unnecessary excluding heavy snow region.

If this function is active, the fan motor of the outdoor unit works at 600 rpm when the snow detection sensor detects snow.

One snow detection sensor can control all outdoor units on the communications wiring. The snow detection sensor can be connected with any outdoor unit regardless of the main or sub and it can control all outdoor units in communication wiring.

\* To activate this function, it is necessary to set it to all EEPROMs on outdoor PCBs.

CODE: 04

Setting No	Operation
0	Snow detection sensor is NOT connected with this unit. But this function is performed according to the signal of the sensor connected with other outdoor unit. (Factory preset mode)
1	Snow detection sensor is connected with this unit. And this function is performed according to the sensor signal.
2	Snow detection sensor is NOT connected with this unit. And this function is NOT performed.
3	Snow detection sensor is connected with this unit. But this function is NOT performed.

Snow detection sensor

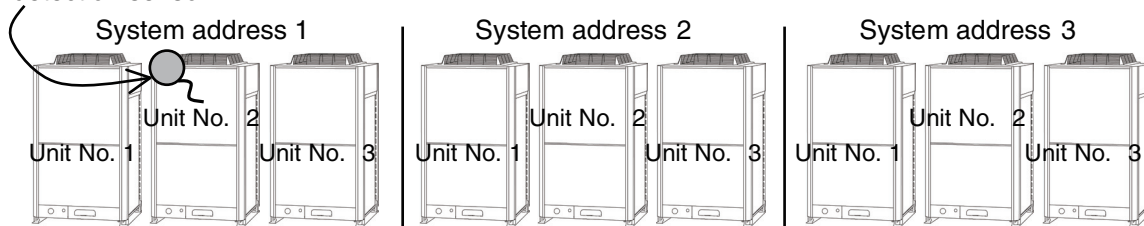

Setting No.	0	1	0	0	0	0	2	2	2
Fan motor state in case of snow	ON	ON	ON	ON	ON	ON	OFF	OFF	OFF

\* All main outdoor units are connected with same communication wiring

Some components of indoor unit are under CCU's control.

## 6-1. MOV of indoor unit

### 6-1-1. Indoor unit without RAP valve kit

Mode of indoor unit	Mode of outdoor unit	Compressor	Thermostat ON/OFF	MOV pulse of indoor unit
Stop	Cooling	Stop	-	20
		Operation	-	20
	Heating	Stop	-	85
		Operation	-	55- 80 pulses (Accumulation prevention of refrigerant)
Fan (only)	Cooling	Stop	-	20
		Operation	-	20
	Heating	Stop	-	85
		Operation	-	55- 80 pulses (Accumulation prevention of refrigerant)
Cooling	Cooling	Stop	-	20
		Operation	OFF	20
			ON	60 - 480 pulses (SH control <sup>1</sup> )
Heating	Heating	Stop	-	85
		Operation	OFF	55- 80 pulses (Accumulation prevention of refrigerant, Occasional room temperature detection control <sup>2</sup> )
			ON	65 - 480 pulses (SC control <sup>3</sup> )

- \*1 SH control adjusts the difference between the liquid temperature and gas temperature in indoor unit.  
SH = gas temperature (E3) - liquid temperature (E1)  
Target SH is 1 - 3 deg when required level of indoor unit is "30" or "31(test run)".  
Target SH will be increased up to 20 deg when required level of indoor unit is small.  
\*When the refrigerant amount in the system is adjusted, it is necessary to select test run that the required level becomes "31".
- \*2 MOV pulse changes to 55 for 1 minute when valve pulse continues to be 55 or more for 10 minutes.  
The purpose is to decrease the flow volume of the refrigerant so that room temperature can be detected with less influence of heat from the refrigerant.
- \*3 SC control adjusts the difference between the liquid temperature in indoor unit and high-pressure sensor temperature in outdoor unit.  
SC = high-pressure sensor temperature (HPS) - liquid temperature (E1)  
Target SC is 5 - 20 deg according to operating condition.

### 6-1-2. Indoor unit with RAP valve kit (Mainly Type E1)

Mode of indoor unit	Mode of outdoor unit	Compressor	Thermostat ON/OFF	MOV pulse of indoor unit
Stop	Cooling	Stop	-	20
		Operation	-	20
	Heating	Stop	-	20
		Operation	-	20
Fan (only)	Cooling	Stop	-	20
		Operation	-	20
	Heating	Stop	-	20
		Operation	-	20
Cooling	Cooling	Stop	-	20
		Operation	OFF	20
			ON	60 - 480 pulses (SH control)
Heating	Heating	Stop	-	20
		Operation	OFF	20
			ON	65 - 480 pulses (SC control)

In case of special controls, MOV performs special operation. For detail, refer to Special Controls section..



## 6. Indoor Units Control from the CCU

### 6-1-3. MOV minimum pulse adjustment function in cooling operation

Minimum pulse which is set to 60 at the factory is able to adjust (shift).

Minimum pulse under SH control = 60 + XX

EEPROM setting in main outdoor unit

CODE: A9 (for indoor unit capacity 5.6kW or less),

AA (for indoor unit capacity 7.3kW),

AB (for indoor unit capacity over 10.6kW)

Setting No	XX
-30	-30
-29	-29
⋮	Interval of "1"
0	0 (factory preset mode)
⋮	⋮
50	50

### 6-2. RAP valve kit

The RAP valve kit connection might be required on the Type E1 indoor unit.

Mode of indoor unit	Mode of outdoor unit	Compressor	Thermostat ON/OFF	RAP valve kit
Stop	Cooling	Stop	-	OFF
		Operation	-	OFF
	Heating	Stop	-	OFF
		Operation	-	OFF
Fan (only)	Cooling	Stop	-	OFF
		Operation	-	OFF
	Heating	Stop	-	OFF
		Operation	-	OFF
Cooling	Cooling	Stop	-	OFF
		Operation	OFF	OFF
			ON	OFF
Heating	Heating	Stop	-	OFF
		Operation	OFF	OFF
			ON	ON

\*RAP valve kit state (ON/OFF) is displayed on "D" in DSBE column when the Checker software is used.

0 : OFF

1 : ON

In case of special controls, RAP valve kit performs special operation. For detail, refer to Special Controls section.

### 6-3. Indoor Fan Speed Control

CCU intervenes in fan control of the indoor unit according to the state at the operating mode below.

The priority order of fan control by CCU is higher than that of indoor unit's.

#### 6-3-1. Dry mode

Indoor unit fan operated in the dry mode is controlled from CCU as shown in the below figure.

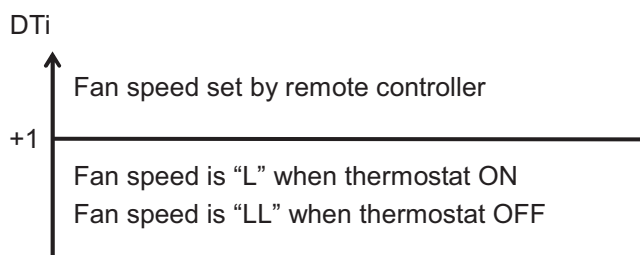

$DTi = (\text{Intake temperature of indoor unit}) - (\text{Preset temperature in remote controller})$



### 6-3-2. Heating mode

Indoor unit fan operated in the heating mode is stopped from CCU at the following condition.

- Discharge air temperature of indoor unit  $\leq 20^{\circ}\text{C}+\text{XX}$
- High pressure sensor temperature (HPS) in outdoor unit  $\leq 25^{\circ}\text{C}+\text{XX}$
- Liquid temperature (E1) in indoor unit  $\leq 20^{\circ}\text{C}+\text{XX}$

\* "XX" is able to be set in EEPROM on the outdoor unit's PCB.

EEPROM setting in main outdoor unit

CODE: 2C

Setting No	XX
-10	-10
-9	-9
-8	-8
⋮	Interval of "1"
0	0 (factory preset mode)
⋮	⋮
20	20

In case of special controls, indoor fan performs special operation. For detail, refer to Special Controls section.

### 6-4. Drain Pump control

CCU intervenes in drain pump control of the indoor unit according to the setting in EEPROM in the outdoor unit.

The drain pump operates from CCU control at the following condition.

- DP counter  $\geq 5$
- \* The DP counter counts each oil recovery control, and 4-way Valve Adjustment Control in cooling operation.
- Liquid temperature (E1) in the indoor unit which selected cooling mode  $< 0^{\circ}\text{C}$
- \* Regardless of operating / stopped.
- Low Silhouette Ducted type indoor unit

In Low Silhouette Ducted types, dirt might be accumulated when water collects in the drain pan for a long term. Therefore, the drain pump works longer to drain water surely.

\* To activate this function, it is necessary to set it to EEPROM on the main outdoor PCB.

EEPROM setting of drain pump in main outdoor unit

CODE: 0C

Setting No		Indoor unit under this control
0	Invalid	All units (Mode, Operation / Stop Thermostat ON / OFF doesn't concern)
1	DP operates for 20 minutes and stops for 2 hours	
2	DP operates for 20 minutes and stops for 20 minutes	
3	DP always operates	
4	DP operates for XX minutes when indoor unit's operation changes; from thermostat ON → thermostat OFF or operation stopped.	Cooling mode Dry mode Heating mode
5	DP operates for XX minutes when indoor unit's operation changes; from thermostat ON or thermostat OFF → operation stopped.	
6	Both Setting No. 4 and 5 functions.	
7 (Factory preset mode)	DP operates for XX minutes when indoor unit's operation changes from thermostat ON or thermostat OFF → operation stopped.	Cooling mode Dry mode

\*When setting No. 4 – 7 is selected, this function works only for below indoor unit types.

Types : F1, M1, E1

\*Operating time mentioned "XX" above is able to set in EEPROM of the main outdoor unit



EEPROM setting in main outdoor unit

CODE: 2B

Setting No	XX
20	20 minutes
30	30 minutes (factory preset mode)
40	40 minutes
50	50 minutes
60	60 minutes

- \* The drain pump always operates when the indoor unit is thermostat ON in cooling operation.
  - \* Once the drain pump operates, it keeps operating for 20 minutes.
- In the above 2 cases, the drain pump operates by the signal of indoor PCB, not by CCU.

### 6-5. Discharge air temperature control

For Type F1, M1, E1 indoor units, discharge air temperature is controlled from the CCU to prevent condensation on duct surface in cooling operation. The CCU monitors and adjusts  $\Delta T_o$  of indoor unit. The adjustment is made by compressor capacity and MOV operation in the indoor unit.

- \*  $\Delta T_o$ : Cooling (Discharge air temperature) - (Preset discharge air temperature)  
Heating (Preset discharge air temperature) - (Discharge air temperature)

Situation in which indoor unit stops by discharge air temperature control

- $\Delta T_o \leq -3.5\text{deg}$ , and this condition continues 7 minutes

- $\Delta T_o \leq -2.0\text{deg}$ , and this condition continues (20 + XX) minutes

\*The above mentioned "XX" is able to set in EEPROM of the main outdoor unit

EEPROM setting in main outdoor unit

CODE: E1

Setting No	XX
-20	-20
-19	-19
-18	-18
⋮	Interval of "1"
0	0 (factory preset mode)
⋮	⋮
10	10

\*In heating operation, this function virtually does not work because preset discharge air temperature is 50°C and this is sufficiently higher than actual discharge temperature.

For preset discharge air temperature that is set in the indoor unit is able to change, refer to manual for indoor unit.

### 7-1. Oil Level

Oil level	Meaning	Conditions of oil	Judgement
2	Sufficient	The compressor contains sufficient oil.	There is no problem.
1	Slightly low	There will be a risk of oil shortage soon.	Confirm that oil is returned after performing the oil recovery control operation.
0	Extremely low	The compressor oil is short against required level for normal operation.	Confirm that oil level is recovered to the required level after performing the oil recovery control between systems.

At the time immediately after the oil level changes from 2 to 1, there is a specified amount of oil in the compressor. Namely, soon after the oil level is changed to 1, the oil in the compressor is sufficient. If the oil level "0" indication continues for more than 5 to 10 minutes, it seems short of oil in the system. Check valves related to oil recovery operation, the refrigerant tubing and for any oil leakage.

## 7-2. Oil level detection

The compressor oil in the crankcase is sent by bypass via a capillary tube to the low-pressure circuit. The temperature detected by an oil sensor is used to determine whether it is oil (warm) or refrigerant (cold).

## 7-3. Self-separator oil recovery control

\* When a low oil level (1 or 0) is detected, oil is recovered from the oil separator to the compressor through ORVR.

## 7-4. Inter outdoor units oil recovery control – utilizing balance tubes

- \* If the low oil level (1 or 0) continues, that outdoor unit (oil-receiving outdoor unit) receives oil from operating outdoor units where the oil level is not low (oil-supply outdoor units whose all compressor oil levels are 2 or 1).
- Control at the oil-supply outdoor unit begins 3 minutes after an outdoor unit falls into low oil level state. Oil supply is performed for a maximum of 5 minutes from each unit.
- When oil supply is ended, oil supply from that outdoor unit will not occur again for a period of [(No. of outdoor units minus 1) x 5 minutes]. In addition, oil supply is ended if the oil-receiving outdoor unit oil level changes to 2, or if the oil-supply outdoor unit oil level becomes "0".
- The supply of oil is received from 1 unit at a time, in sequence, according to the order of priority of their inverter compressors.
- Operation during unit refrigerant oil recovery
  - [1] Oil-receiving outdoor unit  
ORVR turns ON and remains ON.
  - [2] Oil-supply outdoor unit  
RPV turns ON and remains ON.  
RPV bypass valve repeatedly turns ON and OFF according to a constant cycle.
- \* This oil recovery might be performed regardless of oil level according to operating condition.

## 7-5. System oil recovery control

Outdoor unit mode (cooling / heating) is not changed during system oil recovery control.

### 7-5-1. Start of system oil recovery control

- When one of the oil level of compressors is "0" and the oil level of other compressors which are in same outdoor unit is "1" or "0", system oil recovery control will start.
- \* If one compressor oil level is "0" but the oil level "2" exists, this oil recovery is not performed.

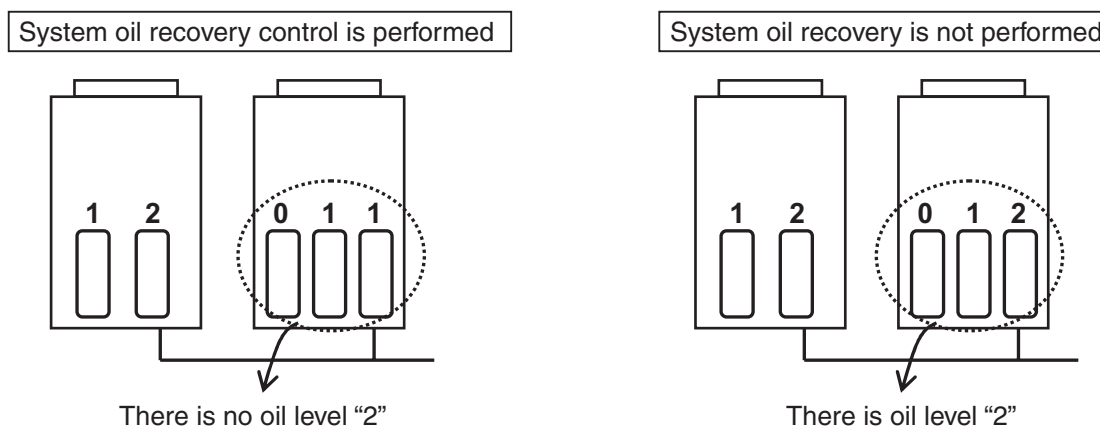

-When the system continues operation for a long time at half of the maximum system capacity, system oil recovery control might be performed at regular intervals\* regardless of oil level.

\* The interval is able to set in EEPROM of the main outdoor unit.

EEPROM setting in main outdoor unit

CODE: 41

Setting No	Interval
30	30
40	40
⋮	Interval of "10"
150	150 (factory preset mode)
⋮	⋮
300	300

This regular interval system oil recovery can be canceled by EEPROM setting in main outdoor unit.

CODE: 30

Setting No	
0	valid
1	Cancel

-After this control is performed, it is not performed again for XX minutes.

\* XX is fixed as 150 minutes in the system which consists of one outdoor unit.

\* XX is able to set in EEPROM of the main outdoor unit in the system which consists of two or more outdoor units.

EEPROM setting in main outdoor unit

CODE: 4D

Setting No	XX
0	0
1	15
2	30 (factory preset mode)
3	45
4	60

## 7-5-2. Simplified flow of system oil recovery control

System oil recovery control shall be performed as the flow mentioned below.

Normal operation → (Time before oil recovery 1 + 2) minute stop → Refrigerant oil recovery control between systems (Oil recovery control processing time + 1 minute) → (Time after oil recovery 1 + 2) minute stop →

Normal operation

-Cooling cycle

Control time	Maximum 2 minutes* (Stops once before and once after control.)	
Outdoor units	All outdoor units operate at maximum horsepower.	
Indoor units	MOV	MOV at all indoor units operate at a fixed pulse according to the indoor unit capacity.
	RAP valve kit	RAP valve kits at all indoor units operate in Cooling mode (OFF status.)
	Fan	Fan operates at the set fan speed, or stops depending on the operation mode of the indoor unit.

-Heating cycle

Control time	Maximum 2 minutes* (Stops once before and once after control.)	
Outdoor units	All outdoor units operate at maximum horsepower.	
Indoor units	MOV	MOV at all indoor units operate at 480 pulse.
	RAP valve kit	RAP valve kits at all indoor units operate in Heating mode (ON status.)
	Fan	Fan operates at the set fan speed, stops or operates at a very low speed, depending on the indoor unit operation mode.

## 7. Oil Control

- \* It is possible to change the oil recovery control processing time EEPROM setting in main outdoor unit

CODE: 43

Setting No	Oil recovery control processing time
0	0 seconds
30	30 seconds
60	60 seconds (factory preset mode)
⋮	Interval of "30"
570	570 seconds
600	600 seconds

- \* There is no stop time before and after defrosting operation in factory setting. However, it is possible to stop by setting.

EEPROM setting in main outdoor unit

CODE: F4 (Time before oil recovery 1)

F5 (Time before oil recovery 2)

F6 (Time after oil recovery 1)

F7 (Time after oil recovery 2)

Setting No	Time above mention
-1	Non stop (factory preset mode)
0	0 seconds
30	30 seconds
60	60 seconds
⋮	Interval of "30"
570	570 seconds
600	600 seconds

### 7-6. Indoor unit self oil recovery control

This control is carried out regularly when the system is in cooling mode.

-During stopped, fan or thermostat OFF condition, indoor unit expansion valve is opened regularly for 1 to 2 minutes regularly (at an interval of once every 2 hours.)

-During the thermostat ON, the indoor unit electronic thermostatic expansion valve is opened about 10 pulses from the current status.

The state of the indoor unit is shown in the table below. Type K1 operates differently according to the setting.

				EEPROM setting in main outdoor unit CODE: 24			
				Setting No. 0		Setting No. 1	
Type of indoor unit	Mode of indoor unit	Thermostat ON/OFF	Pulse of MOV	Fan speed	Flap	Fan speed	Flap
K1	Stop	-	100 - 180	Stop	-	LL	Close
	Fan (only)	-	100 - 180	LL	-	LL	Close
	Cooling	OFF	115 - 185	Set speed	-	Set speed	-
		ON	Present pulse + 20	Set speed	-	Set speed	-
Excluding K1, E1	Stop	-	100 - 180	Stop	-	Stop	-
	Fan (only)	-	100 - 180	Stop	-	Stop	-
	Cooling	OFF	115 - 185	Set speed	-	Set speed	-
		ON	Present pulse + 20	Set speed	-	Set speed	-
E1	Stop	-	100 - 180	Stop	-	Stop	-
	Fan mode	-	100 - 180	LL	-	LL	-
	Cooling	OFF	115 - 185	Set speed	-	Set speed	-
		ON	Present pulse + 20	Set speed	-	Set speed	-

\*MOV pulse might be a little different from the above values according to the operating condition.

This control can be disabled by setting to EEPROM.

EEPROM setting in main outdoor unit

CODE: E0

Setting No	
0 (factory preset mode)	This control is performed (all indoor unit)
1	This control is not performed (all indoor unit)
2	Only type K1 is not performed

The purpose of this control is to change over the 4-way valve appropriately with big differential pressure.

This control is performed at the following conditions.

- The first operation after turning on power supply to outdoor unit.
- The first operation after all outdoor units stopped for XX minutes.
- The mode of the system changes.

\* XX is able to set in EEPROM of main outdoor unit.

EEPROM setting in main outdoor unit

CODE: 28 (for cooling mode), 29 (for heating mode)

Setting No	XX
0	60 (factory preset mode)
1	10
2	20
⋮	Interval of "10"
29	290
30	300

- Cooling operation

Control time	60 seconds	
Outdoor units	All outdoor units operate at the maximum horsepower.	
Indoor units	MOV	MOV at all indoor units operate at a fixed pulse according to the indoor unit capacity.
	RAP valve kit	RAP valve kits at all indoor units operate in Cooling mode (OFF status).
	Fan	Fan operates at the set fan speed or stops, depending on the indoor unit operation mode.

\* When the above operation is finished, normal operation starts at the horsepower determined by the indoor units where thermostats are ON.

- Heating operation

Control time	Minimum 1 min - Maximum 10 min [until max (pressure sensor temp., E1) ≥ 35°C]	
Outdoor units	All outdoor units operate at the maximum horsepower.	
Indoor units	MOV	MOV at all indoor units operate at 250 pulses as a default.
	RAP valve kit	RAP valve kits at all indoor units operate in heating mode (ON status).
	Fan	Fan operates at the set fan speed, stops or operates at a very low speed, depending on the indoor unit operation mode.

\* When the above operation is finished, normal operation starts at the horsepower determined by the indoor units where thermostats are ON.



## 9-1. Defrost Methods

This system uses the following 2 defrosting systems.

System employs	Defrost control method
1 outdoor unit in the refrigerant system	Reverse cycle defrost
2 or more outdoor units in the refrigerant system	Outdoor unit cycle defrost

## 9-2. Constraint conditions

- Frost detection does not occur for 5 minutes after operation starts.
- Defrost does not begin again for 35 minutes of operation after defrost was once completed.
- If all indoor units are stopped while defrosting, or if the outdoor unit is stopped due to protection control or another reason, then defrost control will not start for a minimum of 10 minutes after restart occurs.

## 9-3. Frost detection

(A) Frost detection does not occur for 5 minutes after operation starts.

(B) Frost is detected when either condition 1 or 2 below is met.

Condition 1: L2 line or below is detected twice, each time continuously for 4 minutes, when the compressor is operating.

Condition 2: L1 line or below is detected for a total of 60 minutes when the compressor is operating.

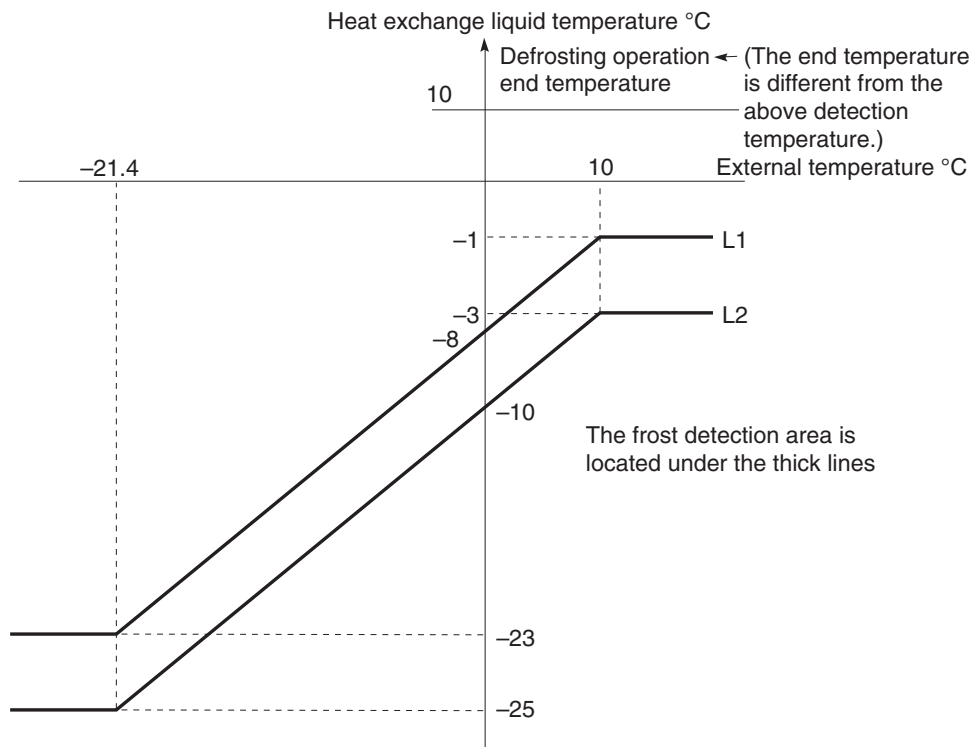

## 9. Defrost Control

### 9-4. Outdoor units where defrost occurs

Even if the total time has not reached 35 minutes, if there is 1 or more outdoor units that fulfill the defrost detection conditions, all operating outdoor units perform defrost control at the same time.

EEPROM setting in main outdoor unit

CODE: A3

Setting No	XX
20	20 minutes
21	21 minutes
22	22 minutes
⋮	Interval of "1"
35	35 minutes (factory preset mode)
⋮	⋮
49	49 minutes
50	50 minutes

\* Defrost control is also performed at outdoor units where the outdoor unit heat exchanger is not functioning as an evaporator (such as stopped outdoor units).

### 9-5. Defrost end judgment conditions

Defrost ends when either of the below defrost end judgment conditions is met.

Condition 1: The temperatures are 10°C or higher at all liquid temperatures sensors installed on the outdoor unit heat exchanger. If there is any other outdoor unit where the defrost end condition has not been met, defrost control continues for all outdoor units, and system defrost control is not ended.

Condition 2: The maximum defrost time listed in the table below has elapsed.

EEPROM setting in main outdoor unit

CODE: AD

Setting No	XX
5	5 minutes
6	6 minutes
⋮	Interval of "1"
12	12 minutes (factory preset mode)
⋮	⋮
30	30 minutes

## 9-6. Reverse Cycle Defrost

If there is 1 outdoor unit, a reverse cycle defrost will be carried out.

- Defrost flow E: Evaporator operation
- C: Condenser operation
- E → C: Switching from evaporator operation to condenser operation
- C → E: Switching from condenser operation to evaporator operation

		Defrost preparation		Defrost in progress		Defrost end
Outdoor unit status		E→C	E→C	C		C→E
Compressor		Stopped	Operating	Operating		Stopped
Indoor unit	Stopped		C→E	E	Defrost end judgment	E→C
	Fan (only)		C→E	E		E→C
	Cooling mode	Thermostat ON	C→E	E		E→C
		Thermostat OFF	C→E	E		E→C
	Heating mode	Thermostat ON	C→E	E		E→C
		Thermostat OFF	C→E	E		E→C
Time		Time before defrosting 1 + 2	1 min	Max. 10 min		Time after defrosting 1 + 2

There is no stop time before and after defrosting operation in factory setting.

However, it is possible to stop by setting.

For the maximum defrost time, refer to the table in Sec. 9-5

EEPROM setting in main outdoor unit

CODE: F0 (Time before defrosting 1)

F1 (Time before defrosting 2)

F2 (Time after defrosting 1)

F3 (Time after defrosting 2)

Setting No	Time above mention
-1	Non stop (factory preset mode)
0	0 seconds
30	30 seconds
60	60 seconds
⋮	Interval of "30"
570	570 seconds
600	600 seconds





# 9. Defrost Control

## 9-7. Outdoor unit cycle defrost

Outdoor unit cycle defrost is performed in systems where 2 or more outdoor units are connected to the refrigerant system.

### 9-7-1. Description of outdoor unit cycle defrost

In this defrosting, the outdoor units are divided into two groups. When outdoor units in the first defrosting group operate in defrost mode (heat exchanger operating as a condenser), outdoor units in the second defrosting group operate as an evaporator in the same way as in ordinary heating mode. In this way, outdoor units in the second defrosting group supply heat to the unit where defrost is occurring. When outdoor units in the first defrosting group complete defrost, the other outdoor unit performs defrost in the same way.

### 9-7-2. Defrost sequence

Outdoor unit cycle defrost is always completed in 2 defrost operations.

- When there are 2 outdoor units

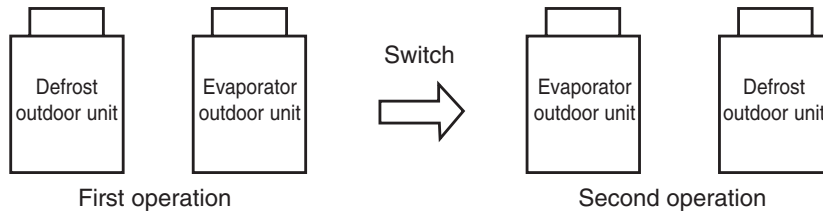

- When there are 3 outdoor units

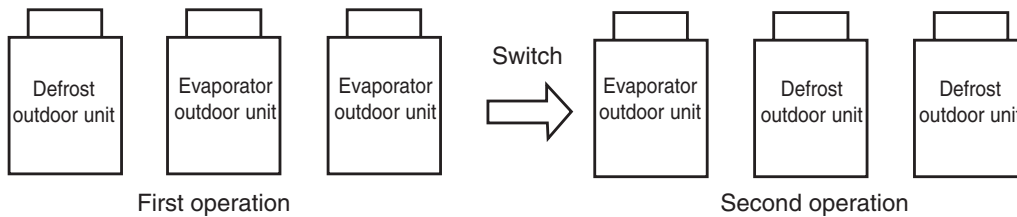

• Defrost flow E: Evaporator operation

C: Condenser operation

S: Shut off

E → C: Switching from evaporator operation to condenser operation

C → E: Switching from condenser operation to evaporator operation

		Defrost preparation	Defrost in progress		Switch	Defrost in progress		Defrost preparation
Outdoor unit(s) where defrost occurs first		E→C	C	Defrost end judgment	C→E	E	Defrost end judgment	E or S
Outdoor compressor(s) where defrost occurs first		OFF	ON		OFF	ON		OFF
Outdoor unit(s) where defrost follows later		E	E		E→C	C		C→E or S
Outdoor compressor(s) where defrost follows later		ON	ON		OFF	ON		OFF
Stopped indoor unit(s)		S	S		S	S		S
Indoor units where fan is operating		S	S		S	S		S
Heating mode indoor units	Thermostat ON	C	C		C	C		C
	Thermostat OFF	C	C		C	C		C
Time		1 min	1 min ~ 5 min		1 min	1 min ~ 5 min		1 min

# 10. Upper Current Limitation Mode

Serial-parallel I/O must be connected in order to perform upper current limitation mode. The below input is received by serial-parallel I/O, and upper current limitation mode is performed.

The upper current limitation values can be set as needed with serial-prallel I/O.

Upper current limitation setting		Control	Upper current limitation meaning
Contact 1	Contact 2		
×	×	No control	Operates to maximum capacity.
○	×	Operates to XX% of the upper limit for the rated current.	-
×	○	Operates to XX% of the upper limit for the rated current..	-
○	○	Always in stop condition.	-

○ : Input present      × : Input not present

\* The rated current indicates the current value that is listed in the catalog or similar material.

\* XX is able to set in EEPROM of main outdoor unit.

EEPROM setting in main outdoor unit

CODE: 1A, 1B

Demand setting		Control	Demand meaning
Contact 1	Contact 2		
×	×	No limit	Operates to the maximum capacity.
○	×	Demand can be set from 40–200% at EEPROM1A.	Current is limited to the set values.
×	○	Demand can be set from 40–200% at EEPROM1B.	Current is limited to the set values.
○	○	Remains stopped.	-

\* A1 has to be bigger than A2.

# 11. Alarm Information

## 11-1. Discharge temperature

### 11-1-1. Discharge temperature protection

The upper limit discharge temperature is 106°C for all compressors. When the discharge temperature reaches 106°C, that compressor is stopped and restarted. If the same high discharge condition occurs XX times, then an alarm occurs.

\* "XX" above is able to set in EEPROM of each outdoor unit

EEPROM setting in main outdoor unit

CODE : B3 : compressor 1

B4 : compressor 2

B5 : compressor 3

Setting No	XX
5	5 (factory preset mode)
10	10
20	20
50	50

After a compressor has stopped, that compressor will not operate until the temperature has dropped to or below the start-prohibit temperature.

### Discharge temperature protection list

Compressor No.	Compressor 1	Compressor 2	Compressor 3
Type	Inverter	Constant-speed	Constant-speed
Stop temp.	106°C	106°C	106°C
Start-prohibit temp.	70°C	70°C	70°C
Alarm display	P03	P17	P18

### 11-1-2. Discharge sensor trouble detection control

-An alarm occurs if the discharge temperature remains abnormally high (above 70°C), when the system has been stopped for 60 minutes.

\*In this case, possible causes include sensor failure and compressor overheating caused by insufficient refrigerant.

-The alarm also occurs if the sensor temperature is at or above the abnormal temperature (100°C) when 30 minutes have passed after the compressor stopped.

\* In this case, it is possible that the discharge temperature from a different compressor unit is being detected, due to an error in the installation of the discharge thermistor.

### Discharge sensor failure list

Compressor No.	Compressor 1	Compressor 2	Compressor 3
Type	Inverter	Constant-speed	Constant-speed
Alarm display	F04	F05	F22

### 11-1-3. Discharge temperature disconnection

An alarm occurs if the discharge temperature doesn't change by 2°C or more when 10 – 30\* minutes have passed since the compressor started.

\* When the ambient temperature is lower than approx 5°C, it is 30 minutes.

\* When the ambient temperature is higher than approx 5°C, it is 10 minutes.

Compressor No.	Compressor 1	Compressor 2	Compressor 3
Type	Inverter	Constant-speed	Constant-speed
Alarm display	H05	H15	H25

## 11-2. Current Protection

### 11-2-1. Inverter compressor and inverter fan moter

Alarm	Description
P16	Occurs during operation when overcurrent is detected. Secondary current of inverter compressor and primary current are limited. The fan motor current is included in primary current.
P29	Occurs when missing phase or overcurrent is detected at inverter compressor start. (the alarm at frequencies below 25Hz)
H31	Occurs when HIC detects overcurrent, or when an abnormal high temperature (150 °C) is reached.

# 11. Alarm Information

## List of overcurrent

	Inverter 6HP	Inverter 10HP
Secondary [ A ]	18.0	21.0
Primary [ A ]	18.0	23.0

### 11-2-2. Constant-speed compressor

An alarm occurs when overcurrent or lock current is detected.

#### List of overcurrent and lock currents

	Constant-speed 5HP	Constant-speed 6HP
Overload current [ A ]	13.6	16.3
Lock current [ A ]	16.1	19.3

## List of Alarms

Compressor No.	Compressor 2		Compressor 3	
Detected current	Over current	Lock current	Over current	Lock current
Alarm display	H11	H12	H21	H22

### 11-2-3. CT circuit detection trouble

	Alarm	Description
Compressor 1 (inverter compressor)	H03	Occurs when an open CT circuit is detected in the inverter compressor.
Compressor 2	H13	Occurs when an open CT circuit is detected in the constant speed compressor. Occurs when a current value of 1.5A or less is detected when the constant-speed compressor is operating.
Compressor 3	H23	Occurs when an open CT circuit is detected in the constant speed compressor. Occurs when a current value of 1.5A or less is detected when the constant-speed compressor is operating.

If the inverter compressor operating frequency is low, the current value is also low. Therefore this alarm is detected only when the compressor is stopped.

The operating current of the constant-speed compressors is always higher than 1.5 A. Therefore, this alarm occurs as the result of an open circuit or failure.

## 11-3. Pressure Sensor Failure

This system contains 2 types of pressure sensors: a high-pressure sensor and a low-pressure sensor.

### 11-3-1. High-pressure sensor failure

An alarm occurs when the high-pressure sensor becomes an electrical open-circuit or a short-circuit conditions, and a broken wiring, short-circuit or poor connection to the PCB in the high-pressure sensor circuit for 30 seconds.

	High-pressure sensor failure
Alarm display	F16

### 11-3-2. Low-pressure sensor failure

An alarm occurs when the low-pressure sensor becomes an electrical open-circuit or a short-circuit conditions, and a broken wiring, short-circuit or poor connection to the PCB in the low-pressure sensor circuit for 30 seconds.

	Low-pressure sensor failure
Alarm display	F17

# 11. Alarm Information

## 11-4. High pressure cut and Low pressure cut

### 11-4-1. Abnormal high pressure

The high pressure switch works when it detects 3.6MPa or more.

If one of the high pressure switches works, whole outdoor units stop and then restart. If the high pressure switch works after the system start for 4 times, an alarm occurs.

	High pressure cut
Alarm display	P04

### 11-4-2. Abnormal low pressure

In the following conditions, an alarm occurs.

- When all outdoor units stop in cooling mode and low pressure sensor detects 0.16MPa or lower, and this condition continues 60 minutes, alarm occurs.
- When an outdoor unit stops in heating mode regardless of system operation and low pressure sensor detects 0.16MPa or lower, and this condition continues 60 minutes, an alarm occurs.

If the following condition occurs after the system starts for XX\* times, alarm occurs.

- The low pressure sensor detects 0.05MPa or lower, and this condition continues 2 minutes.
- The low pressure sensor detects 0.02MPa or lower.

	Low pressure cut
Alarm display	H06

\* "XX" above is able to set in EEPROM of each outdoor unit

EEPROM setting in main outdoor unit

CODE: B1

Setting No	XX
0	5 (factory preset mode)
1	10
2	20
3	50
4	3
5	4

The compressor doesn't start when low pressure detects 0.16MPa or less.

# 11. Alarm Information

## 11-5. 4-way valve failure

If the maximum heat exchanger temperature of the outdoor unit that operates heating mode is 20°C or higher than the ambient temperature and this condition continues for 15 minutes, it is possible that the 4way-valve has not changed during the heating operation.

The incidence of this situation is counted. When this counter reached 5 times, alarm occurs

	4-Way valve failure
Alarm display	L18

## 11-6. Temperature Sensor Failure

When the temperature sensor fails or do not connect with PCB, "F" alarm occurs (excluding discharge temperature sensor for compressor).

Alarm display		
F06	EXG1	Gas temperature sensor in heat exchanger 1
F07	EXL1	Liquid temperature sensor in heat exchanger 1
F08	AIR TEMP	Ambient air temperature
F12	SCT	Suction temperature
F23	EXG2	Gas temperature sensor in heat exchanger 2
F24	EXL2	Liquid temperature sensor in heat exchanger 2
H08	OIL1	Oil temperature sensor 1 (Inverter compressor)
H27	OIL2	Oil temperature sensor 2 (Constant speed compressor 1)
H28	OIL3	Oil temperature sensor 3 (Constant speed compressor 2)

## 11-7. Magnet switch failure

The constant speed compressor cannot stop when the contacts of the magnet switch for compressor melt and cannot cut out.

In this case, system compulsorily operates in cooling mode for safety.

All indoor units operate cooling mode and their fan mode is L (Low Speed).

The fan motor in the outdoor unit which magnet switch cannot cut off operates at maximum rotation speed.

\* Inverter compressor and the other constant speed compressor which magnet switch is normal do not operate.

\* The constant speed compressor contains an over load relay that detects abnormal temperature. Therefore, there is no risk of danger.

# 12. Backup Operation

## 12-1. Automatic Backup Operation

This system includes a function for automatic backup operation. An alarm is displayed on the remote controller to inform the user that a failure has occurred.

### 12-1-1. Alarms that result in automatic backup operation

When the following alarm occurs, automatic backup operation is engaged. Automatic backup operation is not engaged in cases of serious alarm such as communications alarms etc.

- Alarm list 1 (Backup operation continues as long as power supply of all outdoor units doesn't cut)

Alarm display	
H11	Overcurrent of compressor 2 (Constant speed)
H12	Lock current of compressor 2 (Constant speed)
H13	Open CT of compressor 2 (Constant speed)
H21	Overcurrent of compressor 3 (Constant speed)
H22	Lock current of compressor 3 (Constant speed)
H23	Open CT of compressor 3 (Constant speed)
H31	Overcurrent of HIC for inverter compressor
P16	Overcurrent of inverter device
P29	Malfunction of inverter compressor start

\* When there is one outdoor unit in the system, only failed compressor stops.

\* When there are multiple outdoor units in the system, the outdoor unit which mounts the failed compressor stops.

#### <Caution>

After automatic backup operation caused by alarm listed in alarm list 1, it will not be canceled automatically when the repair of the failed outdoor unit is completed. Automatic backup mode will be canceled only when the power on outdoor unit No.1 is reset. Therefore, after repair work is completed, be sure to check whether or not automatic backup mode has been canceled.

- Alarm list 2 (Backup operation continues as long as the problem doesn't solve)

Alarm display		Compressor/outdoor unit operation
F04	Discharge sensor failure for compressor 1	A
F05	Discharge sensor failure for compressor 2	A
F06	Gas temperature sensor in heat exchanger 1	B
F07	Liquid temperature sensor in heat exchanger 1	B
F08	Ambient air temperature	B
F12	Suction temperature	B
F16	High pressure sensor failure	B
F17	Low pressure sensor failure	B
F23	Gas temperature sensor in heat exchanger 2	B
F24	Liquid temperature sensor in heat exchanger 2	B
F22	Discharge sensor failure for compressor 3	A
H08	Oil temperature sensor 1 (Inverter compressor)	B
H15	Discharge temperature of compressor 1 disconnection	A
H25	Discharge temperature of compressor 2 disconnection	A
H27	Oil temperature sensor 2	B
H28	Oil temperature sensor 3	B
P03	Discharge temperature protection of compressor 1	A
P17	Discharge temperature protection of compressor 2	A
P18	Discharge temperature protection of compressor 3	A

**A**

\* When there is one outdoor unit in the system, only compressor that has sensor failure stops.

\* When there are multiple outdoor units in the system, the outdoor unit which contains the problem stops.

**B**

\* When there is one outdoor unit in the system, the backup operation does not work.

\* When there are multiple outdoor units in the system, the outdoor unit which contains the problem stops.

\* Backup operation caused by an alarm listed in "alarm list 2" will finish automatically after 24 hours if the same alarm does not occur again for 24 hours.

## 12. Backup Operation

### 12-1-2. Start of automatic backup operation

If the above alarms occur, the alarm is displayed on the remote controller etc. Pressing the remote controller button again starts automatic backup mode.

### 12-1-3. Backup operation information display

If a wired remote controller is present,  display blinks during operation.

## 12-2. Manual Backup Operation

The manual backup can be used when it is necessary to close the service valve for maintenance etc.

### - Backup operation procedure

#### [1] Disconnecting the failed outdoor unit

(1) Reduce the number of outdoor units set at outdoor unit No.1 by the number of failed outdoor units.

(2) At the S010 switch on the PCB of the failed outdoor unit, turn ON the switches for all compressor to disable, and turn ON the "backup" switch.

Outdoor unit hp	8 hp	10 hp	12 hp · 14 hp · 16 hp	18 hp	20 hp
Switches to turn ON	INV+BU	INV+AC1+BU	INV+AC1+BU	INV+AC1+AC2+BU	INV+AC1+AC2+BU

(3) Close all service valves at the failed outdoor units.

(4) Reset the power at outdoor unit No.1.

\* The outdoor unit that backed up all compressors is not controlled by CCU (main outdoor unit). Even if all compressors of the main outdoor unit are backed up, they are not controlled by CCU. However, the CCU function stays active.

#### [2] Disabling operation of 1 compressor

At the S010 switch on the PCB of the failed outdoor unit, turn ON the switch for the compressor to disable, and turn ON the "backup" switch.

### <S010 switch>

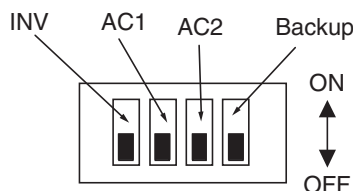

#### (A) Compressor 2 backup

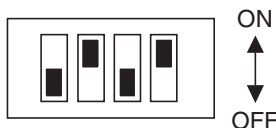

#### (B) Compressor 3 backup

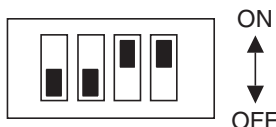

- In order to perform simultaneous backup operation for 2 or more compressors, use a combination of the switch settings shown above.



# 12. Backup Operation

1

All compressors of sub outdoor unit are backed up

Examples:  
Combination of 3 outdoor units with 2 compressors

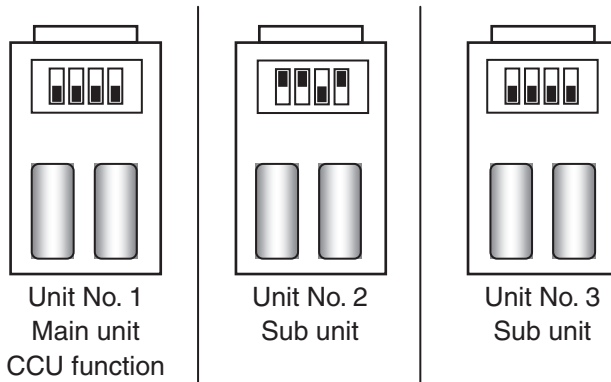

	Main outdoor unit	Sub outdoor unit	Sub outdoor unit
Number of setting	2	Not necessary	Not necessary
Unit No.	1	2	3

All compressors in unit No. 2 are backed up. Therefore the setting No. of outdoor units installed on the main outdoor PCB is changed to "2" from "3".



All compressors of main outdoor unit are backed up

Examples:  
Combination of 3 outdoor units with 2 compressors

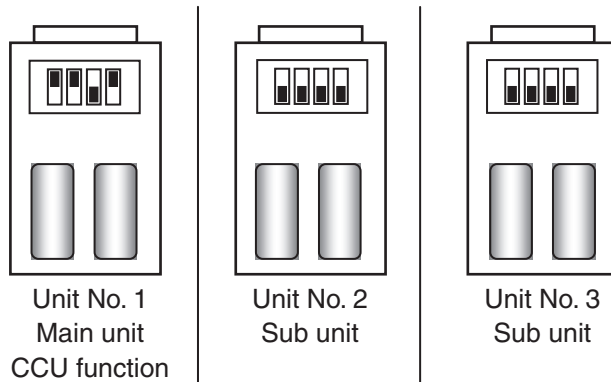

	Main outdoor unit	Sub outdoor unit	Sub outdoor unit
Number of setting	2	Not necessary	Not necessary
Unit No.	1	2	3

All compressors in unit No. 1 are backed up. Therefore the setting No. of outdoor units installed on the main outdoor PCB is changed to "2" from "3".

# 13. Other Functions



## 13-1. Maintenance function for power supply stop of indoor unit. (E06 ignore)

The system can continue operation even if outdoor unit cannot communicate with some indoor units. It is necessary to set to EEPROM the allowed number of operating indoor units not to be able to communicate. When the set value is 0 or more, the system continues operating even if it is not possible to communicate with the stopped indoor units

However, allowed number of indoor units to be able to communicate is fixed to 75% of number of indoor units after the power supply of the outdoor unit.

\* If 75% of the number of indoor units is decimal number, round up.

EEPROM setting in main outdoor unit

CODE: 23

Setting No	Allowed number of missing indoor unit
-1	This function is invalid (factory preset mode)
0	0
1	1
2	2
⋮	Interval of "1"
62	62
63	63

Examples :

In case of 10 outdoor units, setting No. becomes "3".

### Normal operation

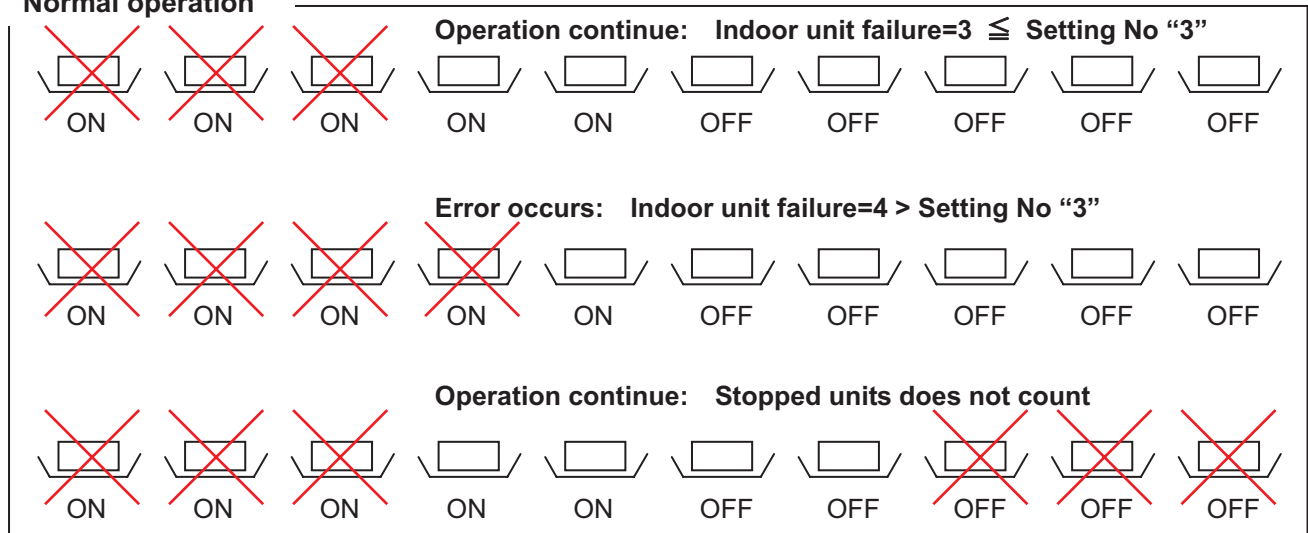

### After power supply of outdoor unit

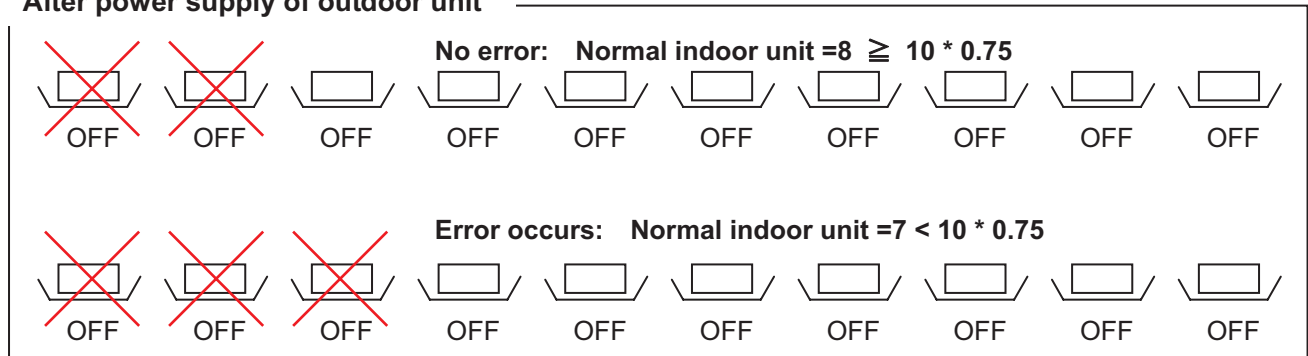

## 13. Other Functions

### 13-2. Auto Change Over Function

It is able to select AUTO mode in each remort controller even in 2way system.

The system switches the mode cooling/heating according to number of thermo ON mode. The system selects the mode that has more number of units with thermostat ON.

The system judges whether to switch the mode in XX minutes intervals.

If No. of thermostat ON indoor unit in cooling mode > No. of thermostat ON indoor unit in heating mode, system selects cooling mode. The heating indoor units will be forced thermostat OFF.

If No. of thermostat ON indoor unit in cooling mode < No. of thermostat ON indoor unit in heating mode, system selects heating mode. The cooling indoor units will be forced thermostat OFF.

\* "XX" above is able to set in EEPROM of main outdoor unit

EEPROM setting in main outdoor unit

CODE: B1

Setting No	XX
0	Invalid (factory preset mode)
30	30
40	40
50	50
60	60
90	90
120	120
180	180
240	240

### 13-3. Function for Automatic Judgment of Insufficient Refrigerant Gas and Overcharge

This system includes a simple function for judging the amount of refrigerant.

#### 13-3-1. Starting refrigerant level judgment mode

Short-circuit the CHK pin on the No. 1 outdoor for 4 seconds or longer to engage this mode. (The LED on the outdoor unit PCB begins blinking.)

#### 13-3-2. Conditions for amount of refrigerant judgment

After judgment mode starts, judgment occurs when all outdoor units in the system have been operating continuously for 30 minutes or longer.

\* Amount of refrigerant judgment requires that all outdoor units operate continuously for 30 minutes or longer.

This is in order to prevent incorrect adjustment of amount of refrigerant based on false detection caused by refrigerant accumulation or recovery at stopped outdoor units, which is due to failures of functional elements.

After the judgment is displayed, repeated judgment will occur under new operating conditions if all outdoor units continue operating. Therefore, the judgment display may change when later judgments occur.

\* Judgment mode is automatically canceled after 4 hours.

## 13. Other Functions

### 13-3-3. Outdoor unit PCB LED indications in judgment mode

Judgment item	LED1	LED2	Recommended response
Judgment mode	Blinking	Blinking	-
Normal	ON	ON	-
Insufficient gas	Blinking	OFF	Charge with refrigerant a little at a time.
Overcharge	OFF	Blinking	Recover refrigerant a little at a time.
Judgment not possible	Blinking alternately		-

When judgment mode is not engaged, the LED indicates the normal display (OFF), or else indicates alarms or other information.

If the insufficient gas or overcharge judgment is not stable, then recover refrigerant a little at a time when the overcharge display appears. End refrigerant adjustment when the normal or insufficient gas display appears.

### 13-3-4. Canceling judgment mode

When judgment mode is cancelled, the LED returns to the standard status display (OFF unless an alarm or other event has occurred).

#### [1] Automatic cancel

Judgment mode is canceled automatically when 4 hours have passed after it was started.

#### [2] Forced cancel

Short-circuit the CHK pin while the judgment mode display is active in order to cancel judgment mode

#### <Reference>General Guidelines for Insufficient Gas and Overcharge

Judgment in automatic judgment mode can be problematic in some cases. Therefore, the following guidelines are provided for general judgment of the refrigerant amount.

#### • Symptoms of insufficient gas

<b>Cooling operation</b>	There is an indoor unit where the position of the electronic control valve is much higher (open by 300 pulses or more) than it was at start, and the difference [E3 – E1] at that indoor unit is large (15 °C or more).
<b>Heating operation</b>	There is an outdoor unit where the position of the electronic control valve is much higher (open by 300 pulses or more) than it was at start, and the difference [Liquid temp. – Gas temp.] at that outdoor unit is large (15 °C or more).

#### • Symptoms of overcharge

<b>Cooling operation</b>	The high-pressure sensor temperature is 57 °C or higher, and the difference [Pressure sensor temp. – Liquid temp.] at that outdoor unit is large (15 °C or more).
<b>Heating operation</b>	There is an indoor unit where the position of the electronic control valve is much higher (open by 300 pulses or more) than it was at start, and the difference [Pressure sensor temp. – E3] at that indoor unit is large (25 °C or more).

These are only guidelines, therefore the judgment may vary depending on the installation conditions, load characteristics, and other elements.

### Detail setting in EEPROM of outdoor unit

#### 01 –4F: CCU parameters

(P) : Factory preset mode

DN	Item	Setting No
01   03	Invalid	-
04	Snow removal control	0(P), 1, 2, 3 (For detail refer to 5-8-2)
05	Silent mode	0(P), 1, 2,3,,, ,11 , 12 (For detail refer to 5-6)
06	Indoor fan mode in defrosting	0(P)=Stop 1= LL
07	Invalid	-
08	Invalid	-
09	Indoor MOV pulse in heating Thermostat ON (Fixed)	0(P)=Invalid, 5, 10, 15,,, , 470, 480 pulse
0A	Indoor MOV pulse in heating Thermostat OFF (Fixed)	0(P)=Invalid, 5, 10, 15,,, , 470, 480 pulse
0B	Stopped Indoor MOV pulse in heating mode (Fixed)	0(P)=Invalid, 5, 10, 15,,, , 470, 480 pulse
0C	Drain pump control	0, 1, 2,,, , 6, 7(P) (For detail refer to 6-4)
0D	Factory use	-
0E	Cooling use only	0(P)=Invalid, 1=Cooling use only
0F	Invalid	-
10	Invalid	-
11	Factory use	-
18	Factory use	-
19	Factory use	-
1A	Upper current limitation setting for contact 1	-1=130, 0=Always stop, 40, 45, 50,,, 100(P),, 125, 130 (For detail refer to 10)
1B	Upper current limitation setting for contact 2	-1=130, 0=Always stop, 40, 45, 50,,, ,70(P),, , 125, 130 (For detail refer to 10)
1C	Factory use	-
20	Factory use	-
21	Factory use	-
22	Factory use	-
23	E06 ignore function	-1(P) =Invalid, 0, 1,,, ,63
24	Dew condensation prevention	0(P)=Invalid, 1=valid (For detail refer to 7-6)
25	SH target shift value of K type indoor unit	0(P), 1, 2, 3, 4, 5
27	Auto change over function for 2way system	0(P)= =Invalid, 30, 40, 50, 60, 90, 120, 180, 240 (For detail refer to 13-2)
28	Stop time to perform 4way valve adjustment control (Heating mode)	0(P)=60, 1=10, 2=20,,, , 30=300 (For detail refer to 8)
29	Stop time to perform 4way valve adjustment control (Cooling mode)	0(P)=60, 1=10, 2=20,,, , 30=300 (For detail refer to 8)
2A	Factory use	-
2B	Drain pump's operation time.	20, 30(P), 40, 50, 60 (For detail refer to 6-4)
2C	Indoor fan control from CCU	-10, -9,,, 0(P),, 20(For detail refer to 6-3-2)
2D	SC target value of indoor unit	0, 1, 2,,, 15(P),, 24, 25

DN	Item	Setting No
30	System oil recovery in regular intervals	0(P)=Valid, 1=Cancel (For detail refer to 7-5-1), 2=No use
31	Factory use	-
32	Invalid	-
34	Invalid	-
35	Condensation temperature adjustment Lower temperature of B area (Tc_L)	-7, -6,,, , 0(P),,,, , 6, 7 (For detail refer to 3-6-2)
36	Condensation temperature adjustment Upper temperature of B area (Tc_U)	-7, -6,,, , 0(P),,,, , 6, 7 (For detail refer to 3-6-2)
38	Factory use	-
39	Aid capacity of compressor adjustment (Additional compressor capacity at part load)	-2, -1, 0(P), 1, 2 (House power)
3A	Factory use	-
3B	Factory use	-
3C	Minimum horse power of compressor in cooling	0(P)=0.1, 1=0.1, 2=0.2,,, ,99=9.9
3D	Minimum horse power of compressor in heating	0(P)=0.1, 1=0.1, 2=0.2,,, ,99=9.9
3E	Delay start of outdoor unit	0(P), 1, 2, 3 (For detail refer to 2-2-2)
3F	Evaporation temperature adjustment Lower temperature of B area (Te_L)	-9, -8,,, , 0(P),,,, , 8, 9 (For detail refer to 3-6-1)
40	Evaporation temperature adjustment Upper temperature of B area (Te_U)	-9, -8,,, , 0(P),,,, , 8, 9 (For detail refer to 3-6-1)
41	Regular intervals of system oil recovery control (Long operation time in the part load)	30, 40,,, , 150(P),,,, ,290, 300 (For detail refer to 7-5)
43	Oil recovery control processing time	0, 30, 60(P), 90,,, , 570, 600 (For detail refer to 7-5-2)
46	Factory use	-
47	Factory use	-
48	Automatic backup operation	0(P)=Valid, 1=invalid
49	Factory use	-
4A	Forced defrosting (SILENT pin action)	0(P)=Silent mode, 1=Forced defrosting
4B	Limit pressure adjustment	0, 1, 2(P), 3 (For detail refer to 3-6-2)
4C	Factory use	-
4D	Interval of system oil recovery control	0=0, 1=15, 2=30(P), 3=45, 4=60 (For detail refer to 7-5)
4E	Upper current limitation mode invalid at defrosting	0(P), 1
4F	Factory use	-

**60 –75: Memory area for production**

DN	Item	Setting No
60   75	For production	

**80 –FF: Outdoor unit parameters**

DN	Item	Setting No
80	Invalid	-
81	Outdoor unit capacity	0, 22, 25, 28, 32, 36, 40, 45, 50, 56, 63, 71, 80, 90, 100, 112, 125, 140, 160, 180, 200, 224(8HP), 250, 280(10HP), 335(12HP), 355, 400(14HP), 450(16HP), 500(18HP), 560(20HP), 600, 630, 670, 710, 800, 840
82   86	Invalid	-
87	Max. inverter Hz of compressor	0, 5, 10, 15,,, ,, 115, 120(P)
88	Min. inverter Hz of compressor	0, 5, 10, 15(P),,,, ,, 115, 120
89	Invalid	-
8E	Invalid	-
8F	High Static Pressure Mode	0(P)=Valid, 1=invalid, 2-6=No use (For detail refer to 5-7)
90   96	Invalid	-
9A	Invalid	-
9B	Invalid	-
A0	Invalid	-
A1	Invalid	-
A2	Invalid	-
A3	The minimum operating time until defrosting	20, 21, 22, 35(P),,,, ,, 89, 90 (For detail refer to 9-4)
A4	Factory use	-
A5	Continuance time of fan step "0"	2, 3, 4, 5(P),,,, ,,8, 9 (For detail refer to 5-3)
A6	Factory use	-
A7	Capacity fine-tuning with MOV of indoor unit	0(P)=Valid, 1=invalid
A8	Invalid	-
A9	Indoor min. MOV pulse shift under SH control (for indoor unit capacity 5.6kW or less)	-30, -29, -28,,, ,, 49, 50 (For detail refer to 6-1-3)
AA	Indoor min. MOV pulse shift under SH control (for indoor unit capacity 7.3kW)	-30, -29, -28,,, ,, 49, 50 (For detail refer to 6-1-3)
AB	Indoor min. MOV pulse shift under SH control (for indoor unit capacity over 10.6kW)	-30, -29, -28,,, ,, 49, 50 (For detail refer to 6-1-3)
AD	Max time of defrosting control	5, 6, 7,,, 12(P),,,, 30 (For detail refer to 9-5)
B1	Pre-trip counts until "H06" alarm	3(P), 4, 5, 10, 20, 50 (For detail refer to 11-4-2)
B2	Invalid	-
B3	Pre-trip counts until "P03" alarm	5(P), 10, 20, 50 (For detail refer to 11-1-1)
B4	Pre-trip counts until "P17" alarm	5(P), 10, 20, 50 (For detail refer to 11-1-1)
B5	Pre-trip counts until "P18" alarm	5(P), 10, 20, 50 (For detail refer to 11-1-1)
B8	Factory use	-
B9	Factory use	-
BA	Outdoor min. MOV1 pulse shift under SH control	-20, -19, -18,,, ,, 29, 30 (For detail refer to 4-8-4)
BB	Outdoor min. MOV2 pulse shift under SH control	-20, -19, -18,,, ,, 29, 30 (For detail refer to 4-8-4)
BC	Invalid	-
BD	Invalid	-
BE	Invalid	-

DN	Item	Setting No
C0	Factory use	-
C1	Refrigerant interception valve (O2)	0(P), 1, 2 (For detail refer to 4-7)
C2	Invalid	-
C3	Invalid	-
C4	Invalid	-
C5	Factory use	-
C6	Factory use	-
C7	Invalid	-
C8	Invalid	-
E0	Indoor unit self oil recovery control	0(P), 1, 2 (For detail refer to 7-6)
E1	Time until thermostat OFF indoor unit by discharge air temperature	-20, -19, -18,,, 0,,, 9, 10 (For detail refer to 6-5)
E2	Invalid	-
E3	Invalid	-
E4	Invalid	-
E5	Invalid	-
E6	Invalid	-
E7	Invalid	-
E8	Invalid	-
E9	Invalid	-
F0	Time before defrosting 1	-1(P), 0, 30, 60,,, ,,, 570, 600 (For detail refer to 9-6)
F1	Time before defrosting 2	-1(P), 0, 30, 60,,, ,,, 570, 600 (For detail refer to 9-6)
F2	Time after defrosting 1	-1(P), 0, 30, 60,,, ,,, 570, 600 (For detail refer to 9-6)
F3	Time after defrosting 2	-1(P), 0, 30, 60,,, ,,, 570, 600 (For detail refer to 9-6)
F4	Time before oil recovery 1	-1(P), 0, 30, 60,,, ,,, 570, 600 (For detail refer to 7-5-2)
F5	Time before oil recovery 2	-1(P), 0, 30, 60,,, ,,, 570, 600 (For detail refer to 7-5-2)
F6	Time after oil recovery 1	-1(P), 0, 30, 60,,, ,,, 570, 600 (For detail refer to 7-5-2)
F7	Time after oil recovery 2	-1(P), 0, 30, 60,,, ,,, 570, 600 (For detail refer to 7-5-2)
FE	Factory use	-
FF	Factory use	-





**2. CONTROL FUNCTIONS-Indoor Unit**

- 1. Room Temperature Control ..... 2-2
- 2. Heating Standby ..... 2-4
- 3. Automatic Fan Speed Control ..... 2-5
- 4. Indoor Unit MOV Control ..... 2-6
- 5. Drain Pump Control ..... 2-6
- 6. Automatic Heating/Cooling Control ..... 2-7
- 7. Discharge Air Temperature Control ..... 2-8
- 8. RAP Valve Kit Control ..... 2-8
- 9. Automatic Flap Control ..... 2-9
- 10. Filter Sign ..... 2-9
- 11. Electric Heater Control ..... 2-10
- 12. Fan Control during Dry Mode ..... 2-10
- 13. Ventilation Fan Output ..... 2-11
- 14. T10 Terminal ..... 2-11
- 15. Parameter ..... 2-12

# 1. Room Temperature Control

## 1. Room Temperature Control

- The body sensor or remote controller sensor detects temperature in the room. The detected temperature is called the room temperature. The body sensor is the one contained in the indoor unit.

	Body sensor is enabled	Remote controller sensor is enabled
Set temp.	Set temp. in remote controller	Set temp. in remote controller
Detected temp. by sensor	Detected temp. by body sensor	Detected temp. by remote controller sensor
Room temp.	Detected temp. by body sensor - *correction temp.	Detected temp. by remote controller sensor

- The thermostat is turned ON or OFF according to the following  $\Delta T$ .

$\Delta T$ (Cooling)	$\Delta T = \text{room temp.} - \text{set temp. (set temp. in remote controller)}$
$\Delta T$ (Heating)	$\Delta T = \text{set temp.} - \text{room temp.}$

※ Correction temperature (only during heating)

If the indoor unit is installed on the ceiling, temperature near the ceiling is higher than near the floor. When the body sensor is enabled, lower temperature near the floor must be considered. To correct this difference in temperature, the correction temperature is used.

The factory setting for the correction temperature is different depending on the model. Refer to "15. Parameter".

Example: Cooling temperature correction

4-Way cassette (correction temperature: 0 degrees)

Body sensor is enabled

Set temp. in remote controller	28°C	28°C	28°C
Detected temp. by sensor	30.0°C	27.5°C	27.0°C
Detected temp. by body sensor	30.0°C	27.5°C	27.0°C
Detected temp. by remote controller sensor	30.0°C	27.5°C	27.0°C
Room temp. = temp. detected by body sensor	30.0°C =30.0	27.5°C =27.5	27.0°C =27.0
$\Delta T$	+2.0deg	-0.5deg	-1.0deg
	Thermostat ON	Thermostat ON	Thermostat OFF

Example: Heating temperature correction

4-Way cassette (correction temperature: 4 degrees)

Body sensor is enabled

Set temp. in remote controller	20°C	20°C	20°C
Detected temp. by sensor	17.0°C	22.0°C	25.0°C
Detected temp. by body sensor	17.0°C	22.0°C	25.0°C
Detected temp. by remote controller sensor	13.0°C	18.0°C	21.0°C
Room temp. = temp. detected by body sensor - 4 deg	13.0°C =17.0-4 deg	18.0°C =22.0-4 deg	21.0°C =25.0-4 deg
$\Delta T$	+7.0deg	+2.0deg	-1.0deg
	Thermostat ON	Thermostat ON	Thermostat OFF

# 1. Room Temperature Control

Remote controller sensor is enabled

Set temp. in remote controller	28°C	28°C	28°C
Detected temp. by sensor	30.0°C	27.5°C	27.0°C
Detected temp. by body sensor	30.0°C	27.5°C	27.0°C
Detected temp. by remote controller sensor	30.0°C	27.5°C	27.0°C
Room temp. = temp. detected by remote controller sensor	30.0°C =30.0	27.5°C =27.5	27.0°C =27.0
$\Delta T$	+2.0deg	-0.5deg	-1.0deg
	Thermostat ON	Thermostat OFF	Thermostat OFF

Remote controller sensor is enabled

Set temp. in remote controller	20°C	20°C	20°C
Detected temp. by sensor	17.0°C	20.5°C	21.0°C
Detected temp. by body sensor	21.0°C	24.5°C	25.0°C
Detected temp. by remote controller sensor	17.0°C	20.5°C	21.0°C
Room temp. = temp. detected by remote controller sensor	17.0°C =17.0	20.5°C =20.5	21.0°C =21.0
$\Delta T$	+3.0deg	-0.5deg	-1.0deg
	Thermostat ON	Thermostat OFF	Thermostat OFF

2

Body sensor is enabled

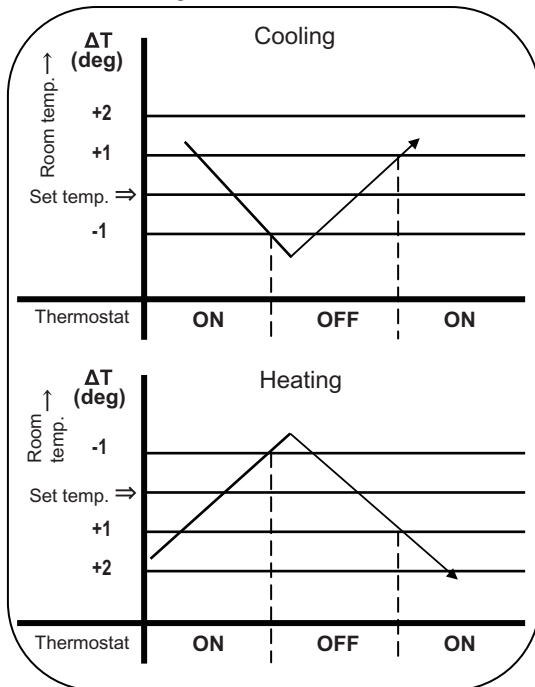

Remote controller sensor is enabled

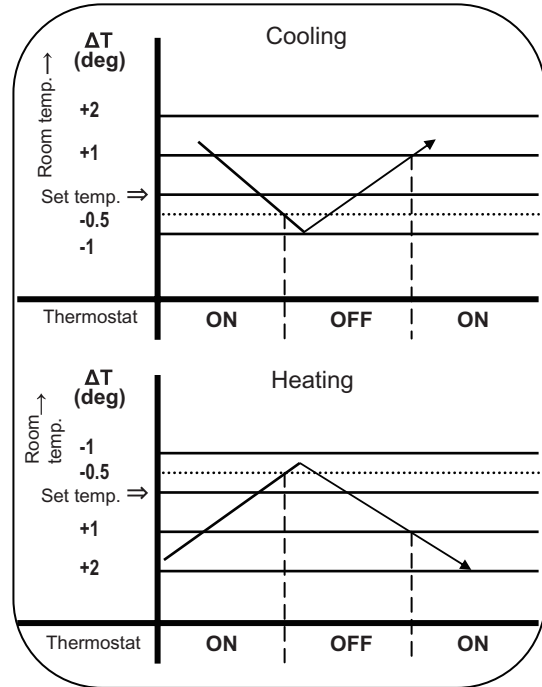

- ① The thermostat does not turn OFF for 3 minutes after it turns ON.
- ② The thermostat does not turn ON 1 to 3 minutes after it turns OFF.
- ③ The thermostat does not turn OFF for 60 minutes during the test run mode. (Forced thermostat ON)  
\*However, the thermostat turns OFF if an alarm occurs.

## 2. Heating Standby

● In heating mode, the indoor fan speed decreases to prevent cold air discharge from the indoor unit. During this time,  (heating standby) is displayed on the remote controller.

① This condition occurs in the following cases.

- Thermostat OFF
- Defrosting operation
- Indoor heat exchanger liquid temperature (E1) < 28°C and discharge air temperature < 25°C just after heating operation started  
The fan speed may sometimes increase when this condition continues for 6 minutes.

② The fan mode increases when the heat exchanger liquid temperature (E1) or discharge air temperature increases.

※ The fan mode is selected based on the discharge air temperature and E1 temperature as shown in the below figure. If the E1 temperature and discharge air temperature are different, the higher temperature is used.

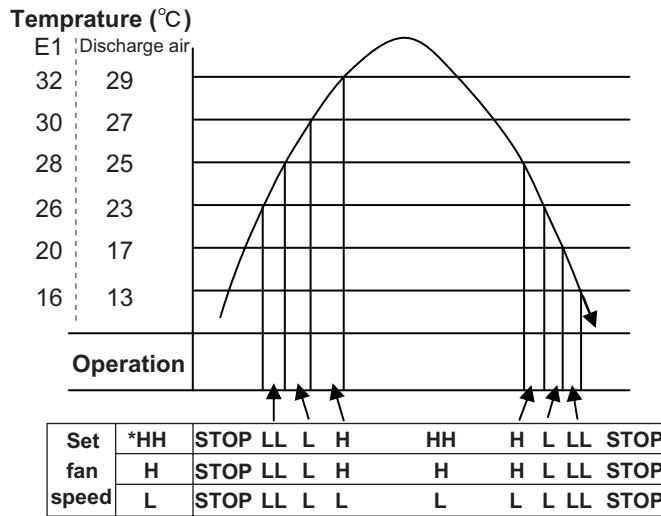

※ The function of "HH" is identical to the automatic fan speed mode.

## 3. Automatic Fan Speed Control

- ① The indoor fan mode is controlled as shown below during the automatic fan mode.
- ② The fan mode does not change for 3 minutes during cooling operation and 1 minute during heating operation once it is changed.
- ③ The values in the parenthesis are when the remote controller sensor is enabled.

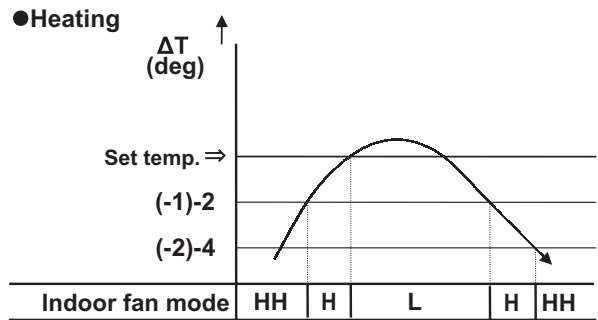
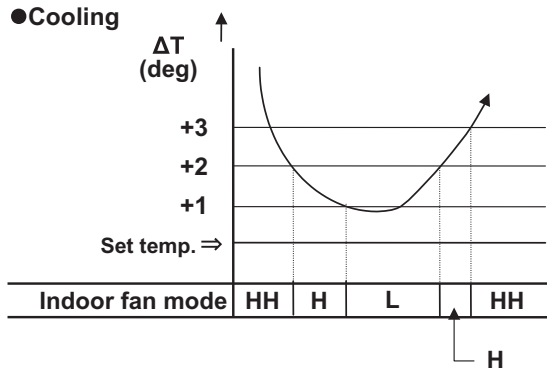

#### 4. Indoor Unit MOV Control

- For details, refer to the section 1 "6. Indoor Unit Control from the CCU".

※ The MOV is at 480 pulses in the following cases.

- ① At the time of factory shipment
- ② Just after the indoor unit power cord is connected.

#### 5. Drain Pump Control

The drain pump operates in the following conditions.

- ① Cooling thermostat ON
- ② The float switch worked.
- ③ The drain pump may often operate for a while when the cooling thermostat turns OFF or the indoor unit is stopped.
- ④ The drain pump can be turned on when the cooling thermostat is OFF if the setting is made to prevent water collected in the drain pan for a long time. For details, refer to "5-2. Detailed Settings Function."
- ⑤ The indoor unit heat exchanger liquid temperature (E1) is less than 0°C when the cooling thermostat is OFF or the indoor unit is stopped.

※ The drain pump operates for 20 minutes once it starts operating.

## 6. Automatic Heating/Cooling Control

- ① The operating mode is selected according to the set temperature and room temperature when the operation is started.  
 Room temperature  $\geq$  set temperature in remote controller - 1°C → Cooling mode  
 Room temperature < set temperature in remote controller - 1°C → Heating mode
- ② The set temperature is corrected according to the operating mode. The correction temperature is +2 degrees in cooling mode and -2 degrees in heating mode at the time of factory shipment.  
 ※ The correction value is different depending on the model. Refer to "15. Parameter" for details.  
 Corrected cooling temperature - control temperature for cooling  
 Corrected heating temperature - control temperature for heating

When setting temperature in remote controller is 20°C in the cooling mode (at shipment) :

Control temp. for cooling	22°C
Set temp. in remote controller	20°C
Control temp. for heating	18°C

- ③ Condition for mode change  
 Heating → Cooling: Room temperature  $\geq$  Control temperature for cooling + 0.5 degree  
 Cooling → Heating: Room temperature  $\leq$  Control temperature for heating -1.0 degree

When setting temperature in remote controller is 20°C in the cooling mode :

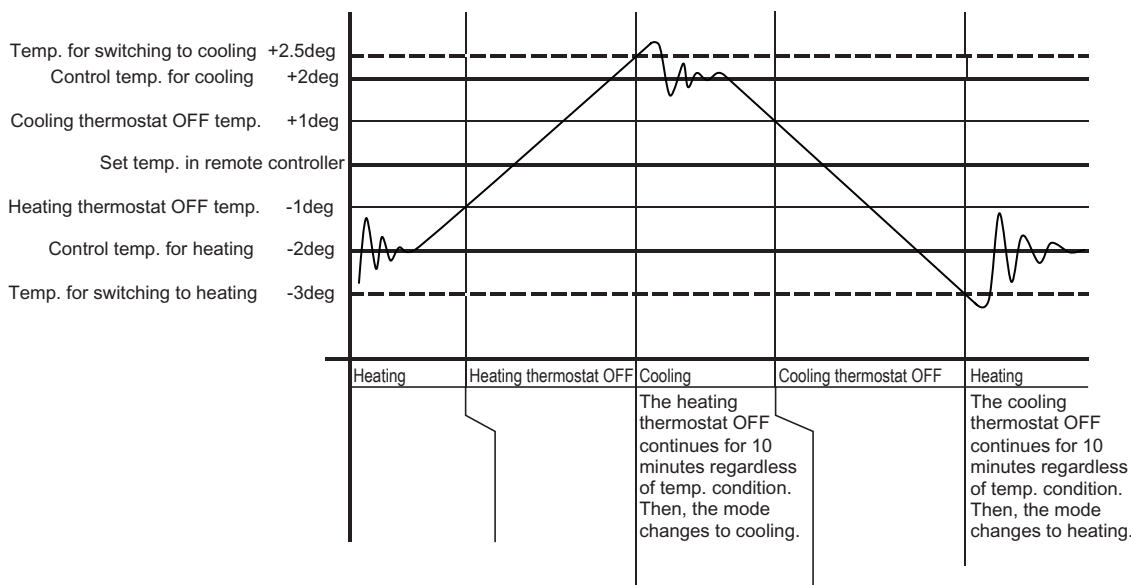

For settings at the time of factory shipment, refer to "15. Parameter".



### 7. Discharge Air Temperature Control

Discharge air temperature is controlled using the indoor unit discharge air temperature sensor. The discharge air temperature is set in the EEPROM on the PCB. The setting is different depending on the model. Refer to "15. Parameter" for details.

Discharge air temperature setting (at the time of factory shipment)

Model	Discharge air temperature setting	
	Cooling	Heating
Low Silhouette Ducted (F1 type)	12°C	-
High Static Pressure Ducted (E1 type)	12°C	-

● Condition for Thermostat ON → OFF under discharge air temperature control

- ① Temperature less than "Discharge air temperature setting - 2°C" is continuously detected for 20 minutes in cooling mode
- ② Temperature more than "Discharge air temperature setting + 2°C" is continuously detected for 20 minutes in heating mode
- ③ Temperature less than "Discharge air temperature setting - 3.5°C" is continuously detected for 7 minutes in cooling mode
- ④ Temperature more than "Discharge air temperature setting + 3.5°C" is continuously detected for 7 minutes in heating mode

※ There is no priority order between the room temperature control and discharge air temperature control.

● Relation between thermostat ON/OFF and room temperature control/discharge air temperature control

Thermostat turns OFF: Either room temperature control or discharge air temperature control satisfies thermostat OFF condition.

Thermostat turns ON: Both of room temperature control and discharge air temperature control satisfy thermostat ON condition.

### 8. RAP Valve Kit Control

※ The RAP valve kit is sometimes used in the 2-Way system.

The RAP valve kit prevents refrigerant from collecting in the indoor heat exchanger when the indoor unit is stopped. The following table shows the RAP valve kit operation.

Operating mode		RAP valve kit
Stopped		OFF
Fan		OFF
Cooling	Thermostat ON	OFF
	Thermostat OFF	OFF
Heating	Thermostat ON	ON
	Thermostat OFF	OFF

### 9. Automatic Flap Control

- The flap position can be selected from 5 positions.

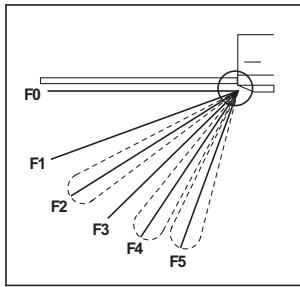

Operating mode	Flap position
Cooling/Dry	F1 • F2 • F3
Fan	F1 • F2 • F3 • F4 • F5
Heating	F1 • F2 • F3 • F4 • F5

- ① The flap moves to the following position automatically when the indoor unit is stopped.  
F0 (close): Types K1, T1, D1, U1, Y1  
F5: Models other than the above
- ② The flap closes once and moves to the set position when the operating mode is changed.
  - ※ If the flap position cannot be adjusted because of a problem, only the swing operation can be used. Check the flap and flap motor.
  - ※ The swing operation can be set for the flap.

### 10. Filter Sign

- ① When accumulated operating time of the indoor unit reaches the set time, the filter sign appears on the remote controller. Clean the filter.  
See page 5-10.
- ② After cleaning the filter, press the filter button on the remote controller once. The filter sign turns off.

### 11. Electric Heater Control

The electric heater control is performed when an electric heater is installed with the indoor unit.

The heater turns ON when all of the following conditions (1 to 3) are satisfied in heating mode (thermostat ON).

- ① Body sensor enabled: ON when  $\Delta T \geq 4.0^\circ\text{C}$  (Remote controller sensor enabled: ON when  $\Delta T \geq 2.0^\circ\text{C}$ )  
OFF when  $\Delta T \leq 1.0$  degree
- ② ON: body sensor temperature  $< 26^\circ\text{C}$ , OFF: body sensor temperature  $\geq 29^\circ\text{C}$
- ③ ON: discharge air temperature  $< 40^\circ\text{C}$ , OFF: discharge air temperature  $\leq 45^\circ\text{C}$

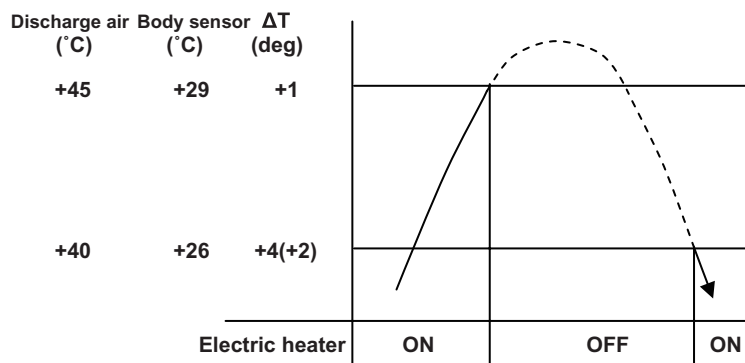

※ For details on  $\Delta T$ , refer to “1. Room Temperature Control”.

### 12. Fan Control during Dry Mode

The fan control during dry mode is as follows.

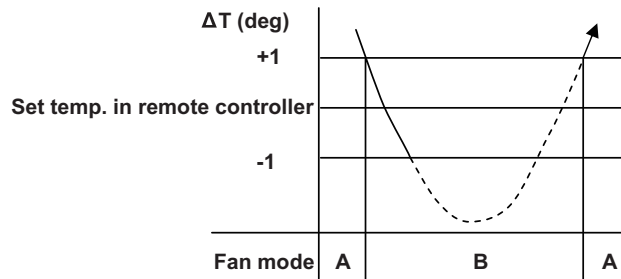

A: Fan mode set in the remote controller

B: Fan mode is L during thermostat ON, LL during thermostat OFF

※ For details on  $\Delta T$ , refer to “1. Room Temperature Control”.

### 13. Ventilation Fan Output

- The output of ventilation turns ON when the indoor unit turns ON. Also, when the indoor unit turns OFF, the output of the ventilation turns OFF.
- The ventilation fan can also be turned ON and OFF using the ventilation button on the remote controller.

Refer to the operating instructions supplied with the remote controller.

To enable this function, set the indoor EEPROM DN31 to "0001" in advance.

### 14. T10 Terminal

Using the T10 terminal, each indoor unit can be operated or stopped separately. Also, operating condition can be checked.

## 15. Parameter

Type	Model	Correction temp. (heating)	Heat/cool switching correction temp. (automatic heat/cool)
		Setting at time of factory shipment	Setting at time of factory shipment
U1	4-Way Cassette	4 deg	2 deg
L1	2-Way Cassette	4 deg	2 deg
D1	1-Way Cassette	4 deg	2 deg
F1	Low Silhouette Ducted	4 deg	2 deg
E1	High Static Pressure Ducted	4 deg	2 deg
T1	Ceiling	4 deg	2 deg
K1	Wall Mounted	2 deg	2 deg
P1	Floor Standing	0 deg	2 deg
R1	Concealed Floor Standing	0 deg	2 deg

### 3. OUTDOOR UNIT REPAIR PROCEDURES

1. Removing Panels . . . . .	3-2
2. Discharging Compressor Oil . . . . .	3-3
3. Backup Operation . . . . .	3-6
4. Recovering Refrigerant. . . . .	3-8
5. Checking for Leakage After Repair . . . . .	3-15
6. Evacuating System . . . . .	3-17
7. Charging Compressor Oil. . . . .	3-19
8. Pumping Out Refrigerant from Outdoor Unit . . . . .	3-24
9. Compressor . . . . .	3-27

# 1. Removing Panels



**CAUTION**

Be sure to turn off the power before maintenance. Then check that the power LED (D200) on the filter PCB of the outdoor unit is not lit.

(1) Front panel removal (Fig. 1)

- Remove the front panel.

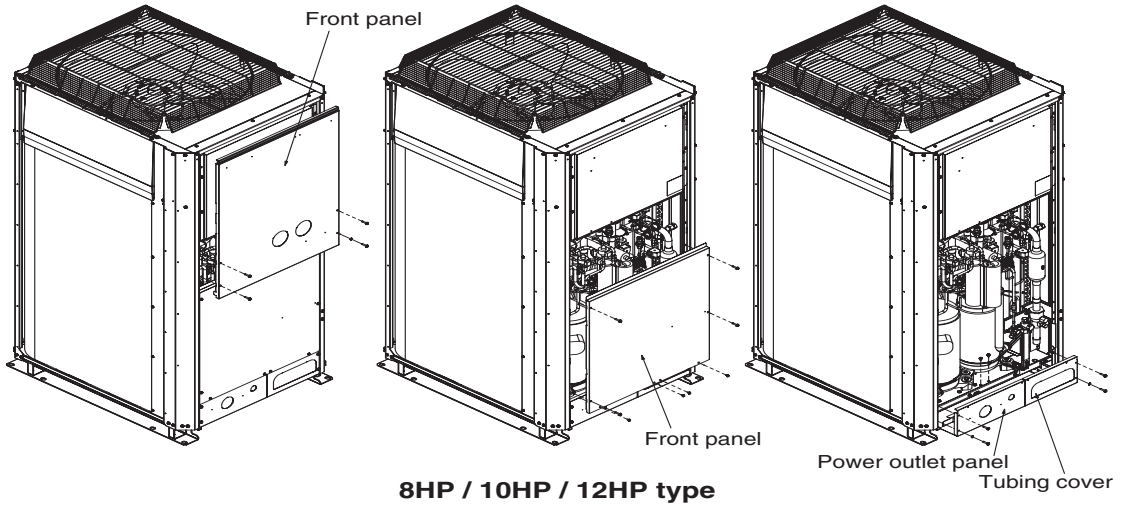

Fig. 1-a

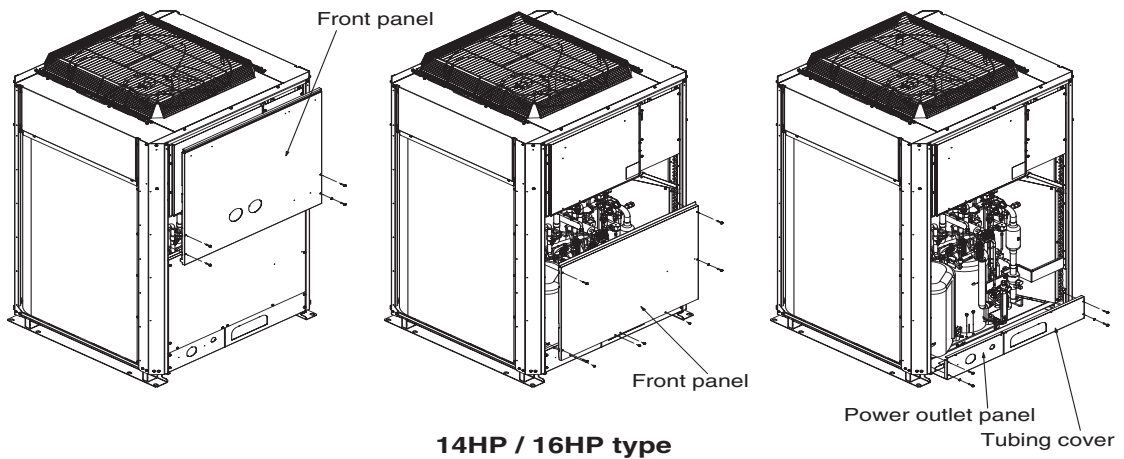

Fig. 1-b

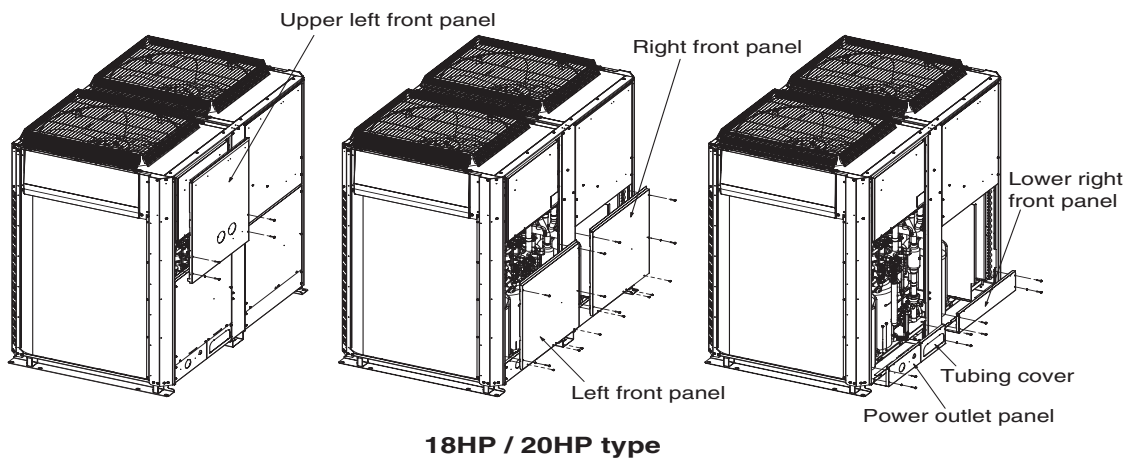

Fig. 1-c

Discharged oil can be used for checking the condition of the system. Based on the appearance and color of the discharged oil, a judgment can be made on whether the system is operating normally or not.

## 2-1. Discharging Oil from Oil Separator

Recover the refrigerant from the outdoor unit following the procedure given in "4. Recovering Refrigerant."

-System with 1 outdoor unit

Open the balance tube valve using the flat head screw driver.

-System with 2 or more outdoor units

Close the balance tube valve of other outdoor unit.

Install hoses as indicated on the equipment and feed nitrogen gas gradually to provide pressure to the system from the low-pressure outlet and collect oil in a pan or container. (Fig. 2)



**CAUTION**

- The low-pressure outlet port is at the Hi: side of the left side.
- A faulty outdoor unit may remain pressurized. The oil outlet port employs a Schrader-type push-to-release valve. Be careful to avoid accidental oil release when using the port.

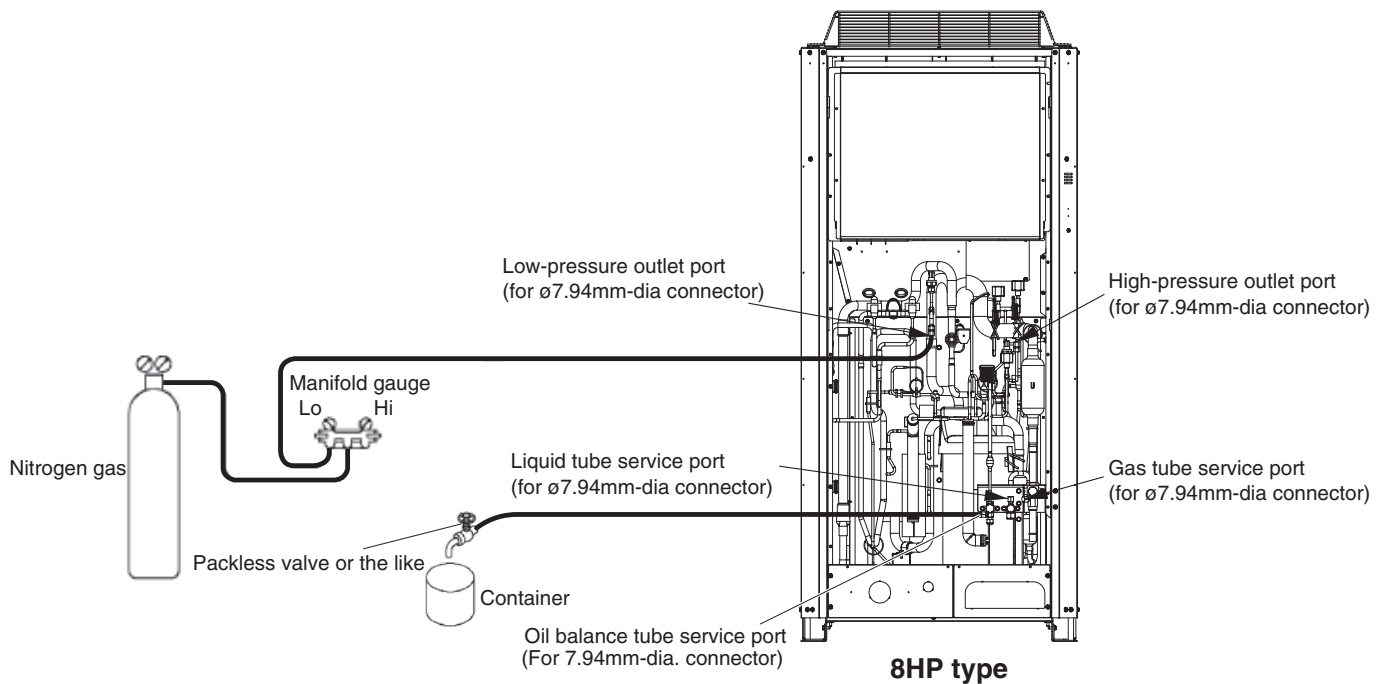

Fig. 2-a



3

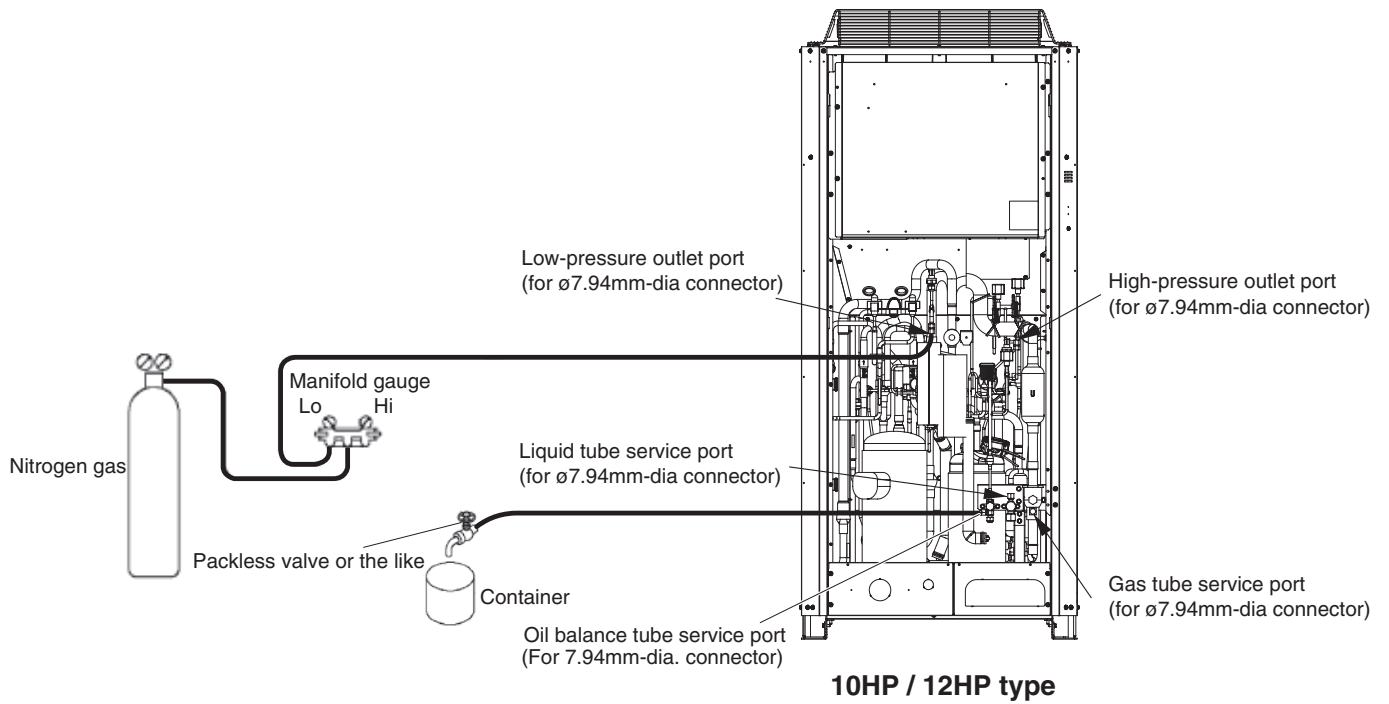

Fig. 2-b

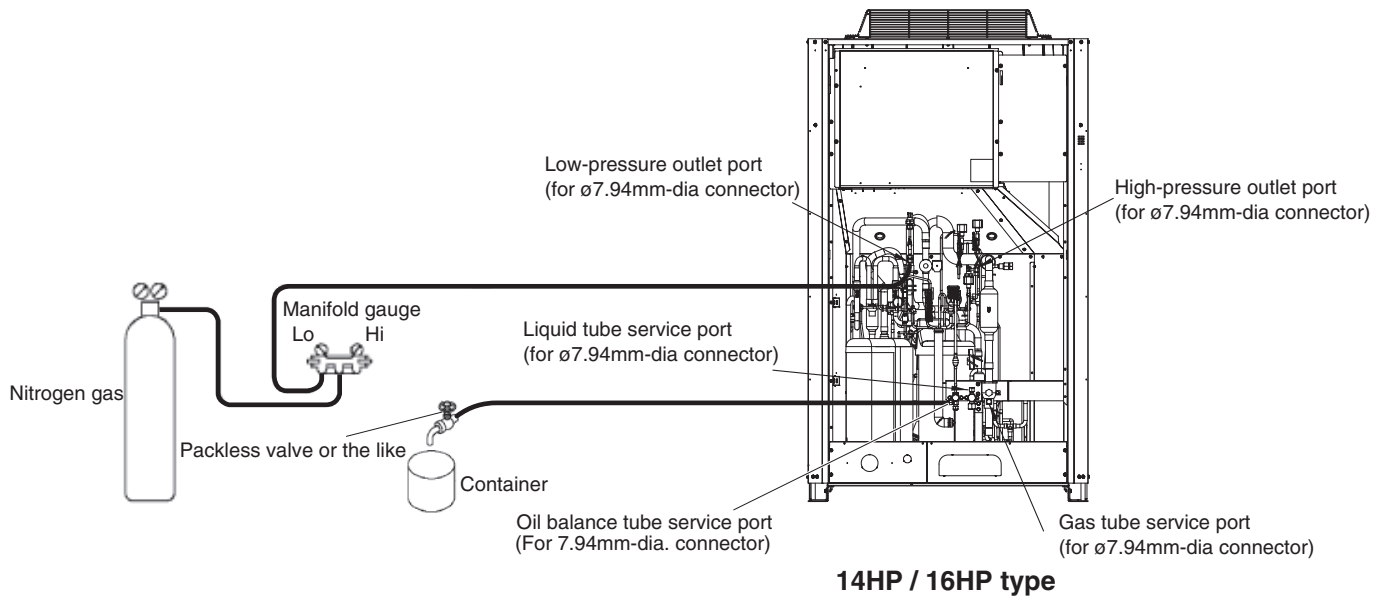

Fig. 2-c

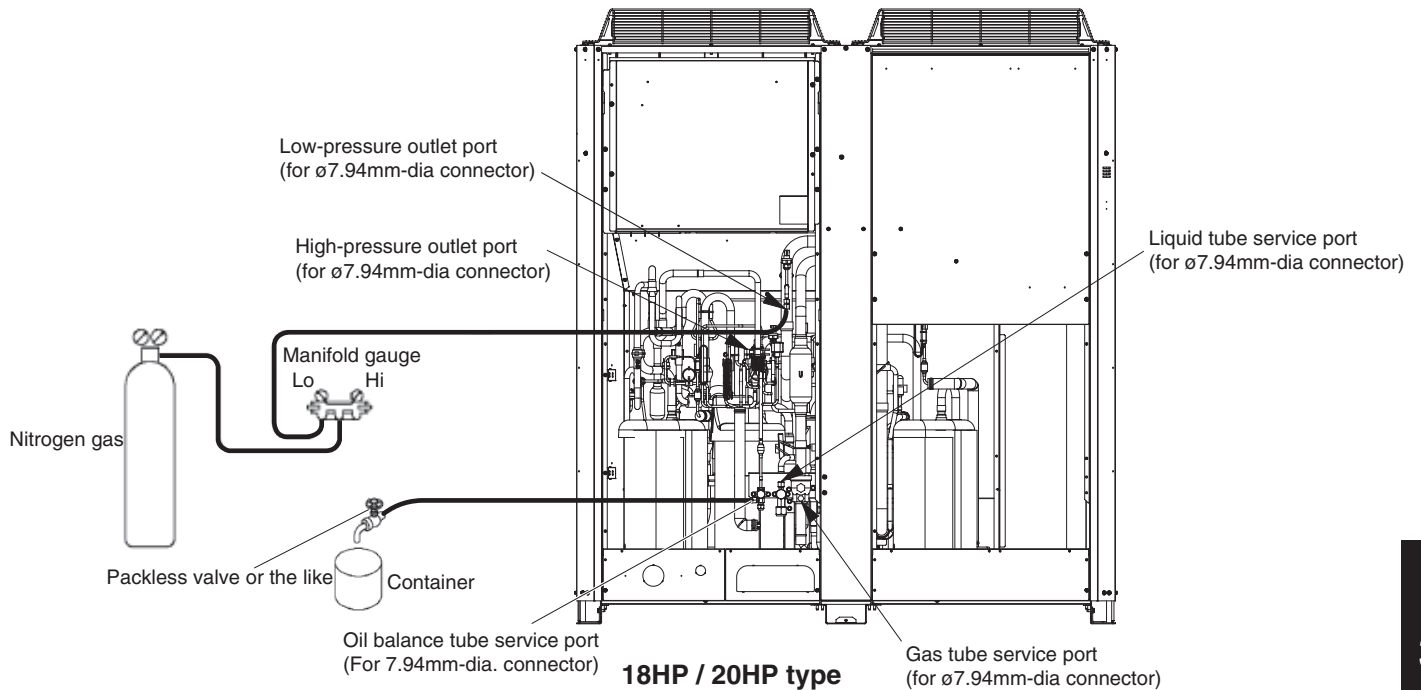

Fig. 2-d

## 2-2. Discharging Oil in Compressor

Recover the refrigerant in the outdoor unit following the procedures in “4. Recovering Refrigerant.” Remove the compressor and discharge the oil in it. Refer to “9. Compressor” for detailed procedures.

## 2-3. Checking the Oil

Acceptance/rejection criteria for the oil

Condition of refrigeration cycle	Condition of oil		Judgment criteria for changing oil*	
	Color	Odor	Total acid value	Hue
Normal	Yellowish	None	0.02 or less	3.5 or less
Abnormal overheat-operation	Brownish	Smells somewhat (not as strong as below)	over 0.06	over 4.0
			Changing the oil and system cleaning with dry-cores are necessary.	
Motor burnout	Brownish / blackish	Pungent / burnt odor	Changing the oil and system cleaning with dry-cores are necessary.	

\* It is difficult to measure the total acid value in the field, therefore oil hue and odor are the rule of thumb. Checking for carbon deposits and abrasive metal powder can additionally be used to assess the system condition.

## 3. Backup Operation

This system includes an emergency automatic backup function that allows the A/C to operate during the period after trouble occurs until repairs are made. However, during repair and at other times, use manual backup operation.

### 3-1. Automatic Backup Operation for Compressor

For details, refer to the control functions section.

After the alarm details are sent to the control device, control for automatic backup operation begins when the ON/OFF button of the wired remote controller is pressed again (operation is started after the alarm is cleared).

During this operating mode, "CHECK" flashes on the wired remote controller only to inform the user that operation is in backup mode. However this is not displayed on any other control devices.

- In order to cancel automatic backup mode, it is necessary to reset the power on the control PCB of the outdoor unit where the outdoor unit No. setting (S007) on the control PCB is set to No. 1 (main unit).

(It is also available by resetting power of all the outdoor units.)



#### CAUTION

**If the power is not reset on the control PCB of the No. 1 outdoor unit (main unit), backup operation will continue after the repairs are completed.**

Backup operation is intended as emergency operation until repairs are made. Have repairs made as soon as possible.

### 3-2. Manual Backup

This backup operation is the conventional method of backup operation. It involves disconnecting the failed outdoor unit from the system, and operating only the normal outdoor units.

For details, refer to the control functions section.

#### 3-2-1. Backup operation by disconnecting the outdoor unit

(1) Changing the outdoor unit control PCB settings

**<If the failed outdoor unit is not the No. 1 unit>**

- Settings at No. 1 unit (main unit)

Switch on outdoor unit control PCB	Action
System address (S003, S002)	No change
No. of indoor units (S005, S004)	No change
No. of outdoor units (S006)	Subtract the number of failed units from the current setting.
Outdoor unit No. (S007)	No change

- Settings at normal outdoor units other than the No. 1 unit

No particular changes

- Settings at the failed outdoor unit

No particular changes

However, close all service valves (gas tubes, liquid tube, and balance tube) at the failed outdoor unit, and disconnect the wiring between the outdoor units.

### 3. Backup Operation

**CAUTION**

After recovery work is completed, wire the communication lines between indoor and outdoor units again. If it not finished yet, an alarm is emitted immediately.

(2) Adjusting the refrigerant for backup operation

During backup operation, all of the service valves on the failed unit are closed. However, if a check of the backup operating conditions shows that the amount of gas is low, recover the refrigerant from the failed outdoor unit. If the amount of gas is too high, collect refrigerant at the failed outdoor unit.

● Recovering refrigerant

With the normal outdoor units operating in cooling, monitor the operating condition and open/close the gas tube service valve on the failed outdoor unit where all the service valves were closed. In this way, recover refrigerant from the failed outdoor unit in order to adjust the amount of refrigerant in the system.

After adjusting the amount of refrigerant, close the gas tube valve at the failed outdoor unit.

● Collecting refrigerant in the failed outdoor unit

• Short-circuit the vacuum application pin (CN050) on the control PCB of the failed outdoor unit where the service valves are closed, then turn the power ON. Also disconnect the wiring between the outdoor units.

• With the normal outdoor units operating, monitor the operating condition and open/close the liquid tube service valve on the failed outdoor unit where all the service valves were closed. In this way, collect refrigerant in the failed outdoor unit in order to adjust the amount of refrigerant in the system.

• After adjusting the amount of refrigerant, turn OFF the power at the failed outdoor unit, release the short-circuit at the vacuum application pin, and close the liquid tube valve at the failed outdoor unit.

\* Refrigerant recovery is not affected by the power status of the failed outdoor unit. However, collecting refrigerant in the failed outdoor unit is affected by whether the power at that outdoor unit can be turned ON. If the power cannot be turned ON, use a refrigerant recovery device and recover the refrigerant into a recovery cylinder in order to adjust the amount of refrigerant in the system.

## The following equipment and tools are required:

Jumper wire with clips, adjustable wrench, set of manifold gauge valves specially designed for refrigerant R410A only, vacuum pump, refrigerant recovery unit, pre-purged refrigerant cylinder for recovery, flathead screwdriver, and outdoor unit maintenance remote controller.

### 4-1. Refrigerant Recovery Procedures (from outdoor unit)

- (1) Turn off the power of the outdoor unit beforehand (at power mains).
- (2) Fully close each service valve on the liquid tube, gas tubes, and the balance tube of the outdoor unit.
- (3) Connect the outdoor unit's high-pressure and low-pressure outlet ports with the Hi and Lo sides of the manifold gauge valves using hoses. (Fig. 3)



**CAUTION**

The remaining refrigerant in the faulty outdoor unit may create internal pressure. Before connecting hoses, be sure to confirm that each of the manifold gauge valves is tightly closed. Note that the connection ports employ Schrader-type push-to-release valves.

- (4) Connect the manifold gauge valves, refrigerant recovery unit, and recovery cylinder using hoses. To avoid the entry of air into the refrigerant tubing, carry out this connection work carefully. (Fig. 3)



**CAUTION**

For detailed procedures such as connecting the refrigerant recovery unit with the recovery cylinder and methods used for recovery, follow the specific instructions that came with the refrigerant recovery unit.

- (5) Locate the AP (Air Purge) pins on the control PCB in the faulty outdoor unit and short them using the clips of the jumper wire. Then restore electrical power to the outdoor unit.



**CAUTION**

By short-circuiting the AP pins, each solenoid valve in the outdoor unit is forcibly opened as soon as power comes on, which releases all remaining refrigerant into the recovery cylinder. Since neglecting this procedure may leave some refrigerant in the system, it is important that you carry out this step.

- (6) Carry out refrigerant recovery.



**CAUTION**

To determine the completion of refrigerant recovery, follow the instructions that came with the refrigerant recovery unit.

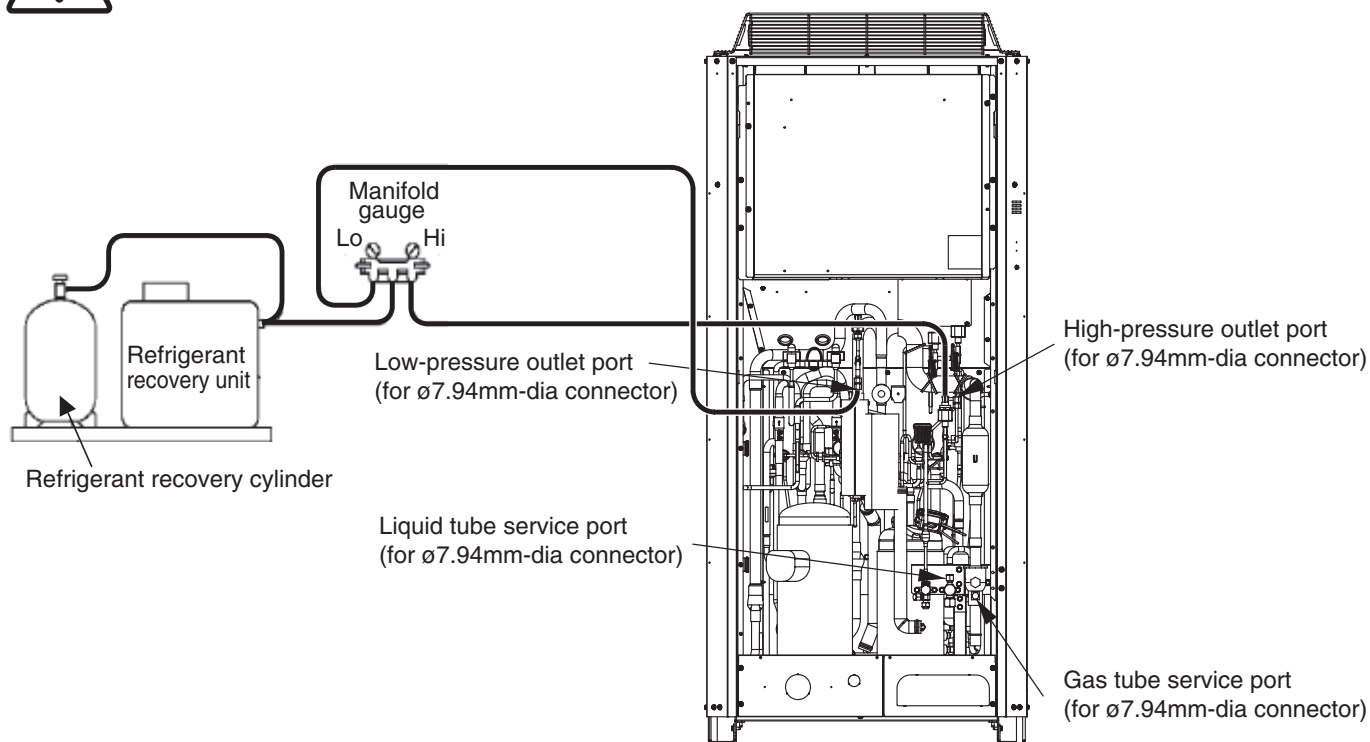

8HP / 10HP / 12HP type  
Fig. 3-a

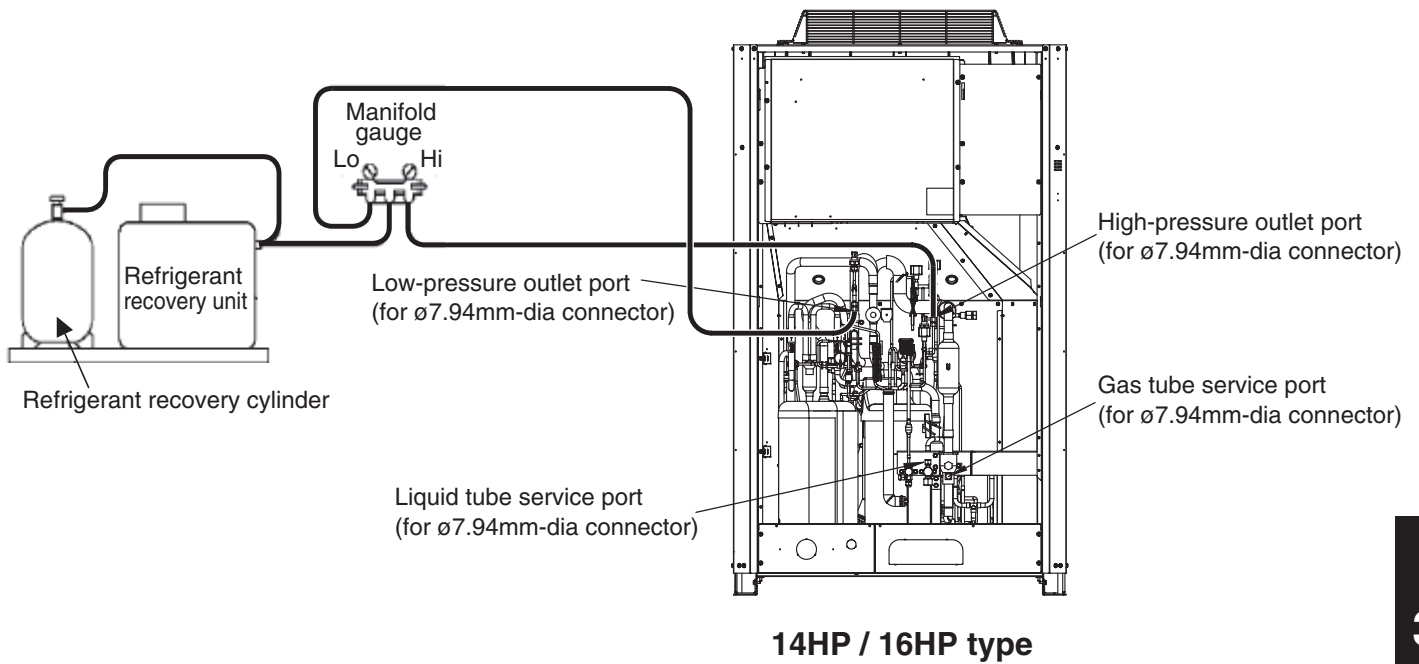

Fig. 3-b

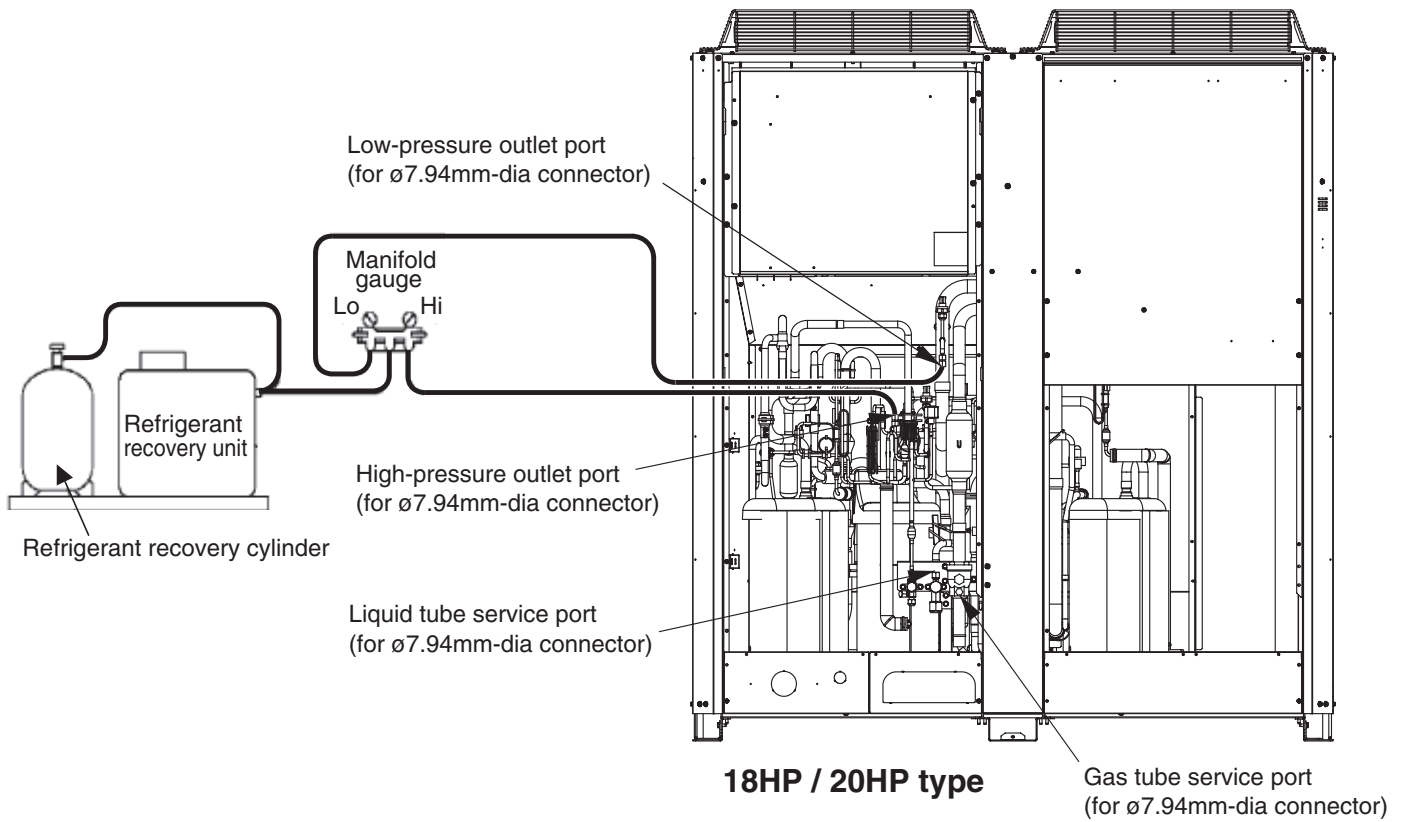
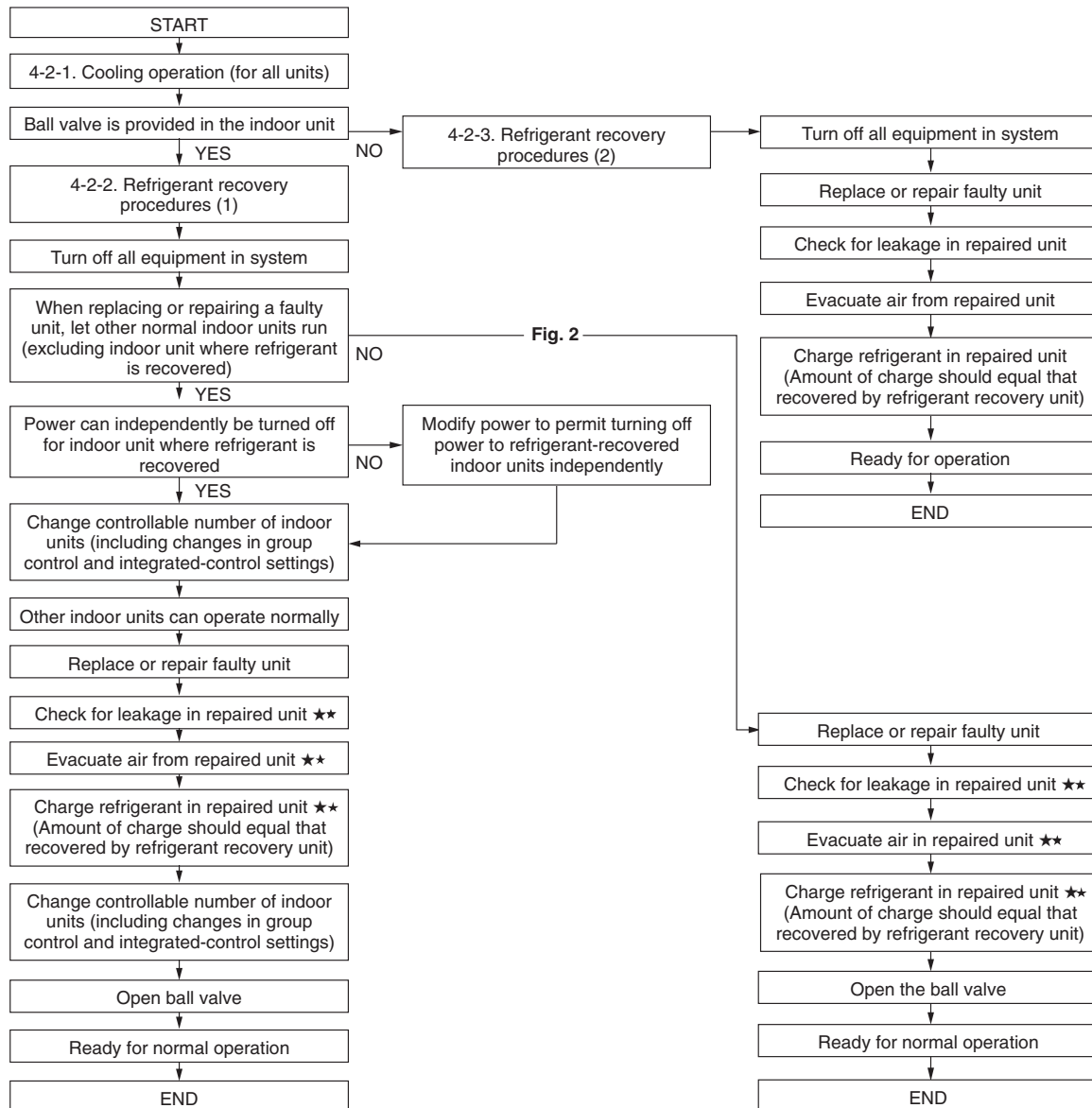

Fig. 3-c

## 4. Recovering Refrigerant

### 4-2. Refrigerant Recovery Procedures (Indoor Unit)

The flowchart below shows the refrigerant recovery procedures you must follow when replacing or repairing the indoor unit due to trouble in the refrigerant circuit.



★ Service work performed on indoor units is done simultaneously using the service ports at the liquid (narrow tube) side and the gas (wide tube) side ball valves. Refer to each section in the “Installation Instructions” on refrigerant charging, leak checking, and evacuation procedures.

#### 4-2-1. Cooling operation (for all units)

(1) If the remote controller (CZ-RTC2) is used for maintenance of the outdoor unit

- ① Connect the outdoor unit maintenance remote controller to the RC connector (CN077) (3P) (BLU) on any one of the outdoor unit control PCBs. Then start a test run of all units. (Press and hold the (CHECK) button for 4 seconds or longer.)
- ② Press the (MODE) button and change to cooling operation and ensure that the cooling is performed. Refer to the test run service manual for the detail of the outdoor maintenance remote controller operation. It may be possible to determine whether operation is cooling or heating by touching the gas tubing.  
Cooling : low temperature (20°C or lower)  
Heating: high temperature (60°C or higher)



**CAUTION**

**The gas tubing becomes hot (60°C or higher) in heating mode. Be careful so as not to be burnt when touching the tubing.**

## 4. Recovering Refrigerant

(2) If the remote controller (CZ-RTC2) is not available for maintenance of the outdoor unit

- ① Determine the outdoor unit where the unit No. setting (S007) (3P DIP switch) (Blue) on the outdoor unit control PCB is set to No. 1.
- ② Short-circuit the test-run pin (CN048) on the PCB to start test run operation.
- ③ Leave the unit running for a while, and touch the gas tubing with fingers to determine whether the unit is running in cooling or heating mode.  
If it is in heating, follow the step and later procedures.  
Cooling : low temperature (20°C or lower)  
Heating: high temperature (60°C or higher)



**CAUTION**

**The gas tubing becomes hot (60°C or higher) in heating mode. Be careful so as not to be burnt when touching the tubing.**

- ④ Release the short-circuit at the test-run pin (CN048) on the outdoor unit control PCB of the No. 1 unit. Then short-circuit the stop pin (CN053) to stop operation.
- ⑤ Short-circuit the COOL pin (CN085) on the outdoor unit control PCB of the No. 1 unit.
- ⑥ Short-circuit the test-run pin (CN048) on the PCB to start test run operation.

### 4-2-2. Refrigerant recovery procedures (1) (using indoor unit ball valve)

- (1) If a ball valve with a service port has been provided in the indoor unit as shown in Fig. 4, follow the instructions given in (2) through (6) below. If the service port is instead located in the outdoor side, follow the instructions in “4-2-3. Refrigerant recovery procedures (2).”
- (2) After running the unit in Cooling mode for about 5 minutes as described in “4-2-1. Cooling operation (for all units),” fully close the liquid tube ball valve.
- (3) Run the unit in Cooling mode for 10 to 20 minutes more.
- (4) Fully close the gas tube ball valve, and stop the operation of all units.
- (5) Use hoses to connect the manifold gauge valves, refrigerant recovery unit, and refrigerant recovery cylinder with each other. (Fig. 4) Do each connection quickly to prevent air from entering the tubing.



**CAUTION**

**Remaining refrigerant may create internal pressure, therefore care should be taken when connecting the hoses.**

- (6) Recover the remaining refrigerant from the indoor unit using the refrigerant recovery unit.

### NOTE

To determine completion of refrigerant recovery, follow the instructions that came with the refrigerant recovery unit.

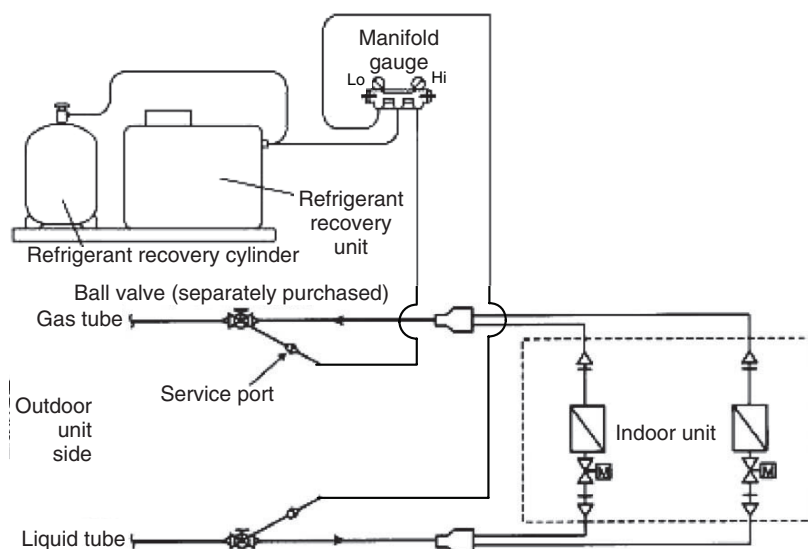

**Fig. 4**



## 4-2-3. Refrigerant recovery procedures (2): Indoor unit with no ball valve equipped

Refrigerant in all indoor units and the refrigerant tubing circuit can be pumped into the outdoor unit. The maximum refrigerant storage capacity per a single outdoor unit is approx. 15 kg to 20 kg. Thus, in order to collect all refrigerant from the system, a separate refrigerant recovery unit is necessary. Follow these procedures to correctly perform pump down.

Perform work correctly, according to the work procedures given below.

- ① Connect the manifold gauge to the high- and low-pressure outlet ports on the outdoor unit where pump down will be performed. Be sure that no air enters the tubing at this time.
- ② Follow the instructions in “4-2-1. Cooling operation (for all units)” and operate all units in Cooling mode for approximately 5 minutes. Then fully close the liquid tube valve on the outdoor unit where pump down will be performed.
- ③ When the high-pressure gauge reaches 2.8 MPa or higher, or the low-pressure gauge reaches 0.5 MPa or below, at the outdoor unit where pump down is being performed, press the ON/OFF button on the outdoor unit maintenance remote controller to stop operation at all units. Then immediately fully close the suction tube valve on the outdoor unit where pump down is being performed.

\* If the outdoor unit maintenance remote controller is unavailable, short-circuit the stop pin (CN053).



**CAUTION**

**It is not necessary to recover the refrigerant from the balance tube. Therefore do not operate the balance tube valve.**

- ④ Turn off power to all equipment in the system. Then pull out the RC1 connector (4P) (BLU) (CN076) on the outdoor control PCB in the outdoor unit for which pump down has been completed.
  - \* By pulling out the RC1 connector, communication between the main and the sub outdoor units will be isolated.
- ⑤ Change the setting of controllable outdoor unit numbers (reduce by 1 unit).
  - \* If the setting is incorrect, the E30 alarm (outdoor unit serial communication signal error) occurs and the unit will not operate.
- ⑥ Turn on power for all equipment in the system and let the remaining outdoor units run in Cooling mode.
- ⑦ Repeat steps ① and ② and complete pump down for all outdoor units.
- ⑧ Using hoses with Schrader-type push-to-release valves, connect the manifold gauge valves to the suction line service port, the discharge line service port and the liquid line service port in the next outdoor unit to undergo pump down. (Fig. 5)



**CAUTION**

**Remaining refrigerant in the system may cause internal pressure. Check that each valve on the manifold gauge is tightly closed. A Schrader-type push-to-release valve is provided for each connection port.**

- ⑨ Use hoses to connect the manifold gauge valves, refrigerant recovery unit, and refrigerant recovery cylinder. Quickly connect each part to prevent air from entering the tubing.
- ⑩ Recover remaining refrigerant from the inter-unit tubing and indoor units using the refrigerant recovery unit.

### NOTE

To determine the completion of refrigerant recovery, follow the instructions that came with the refrigerant recovery unit.

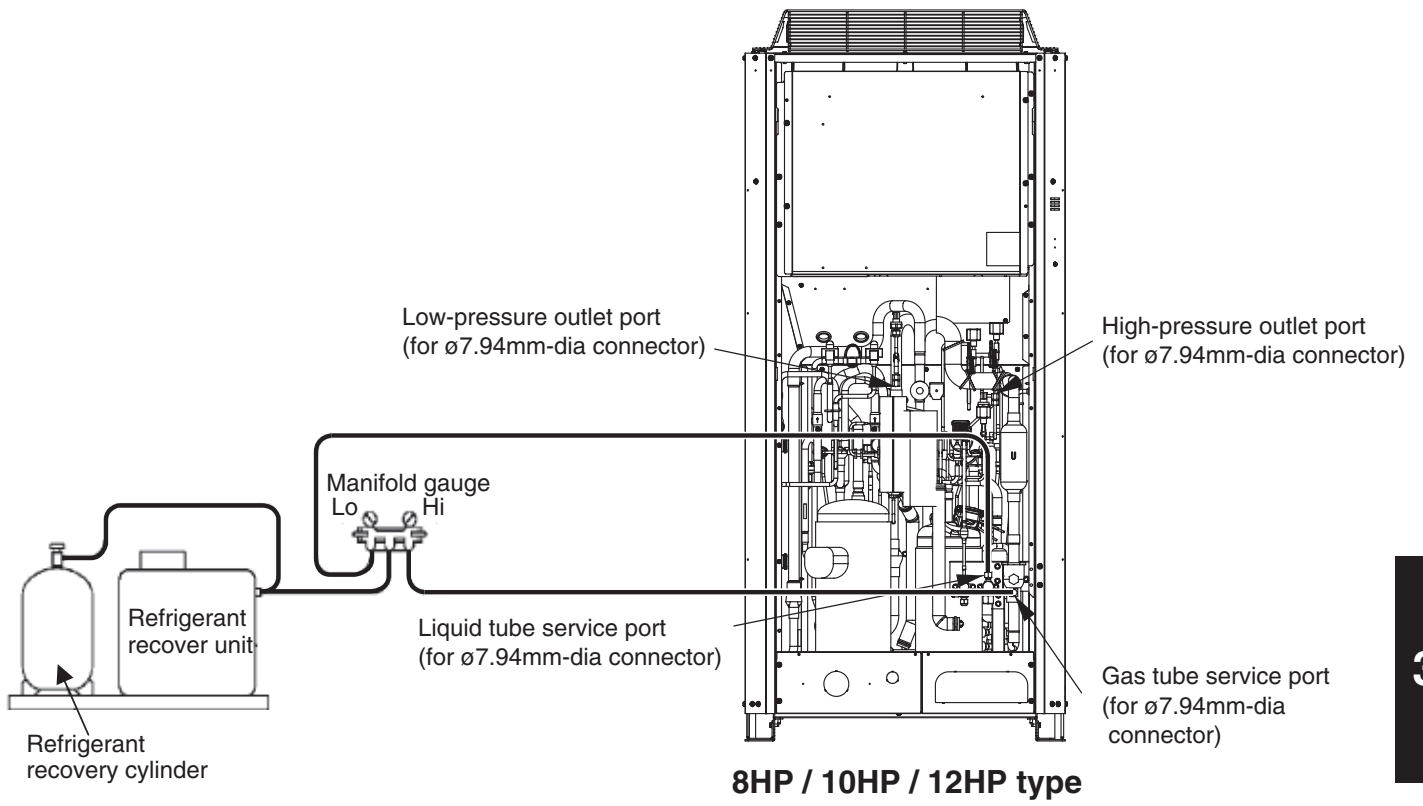

Fig. 5-a

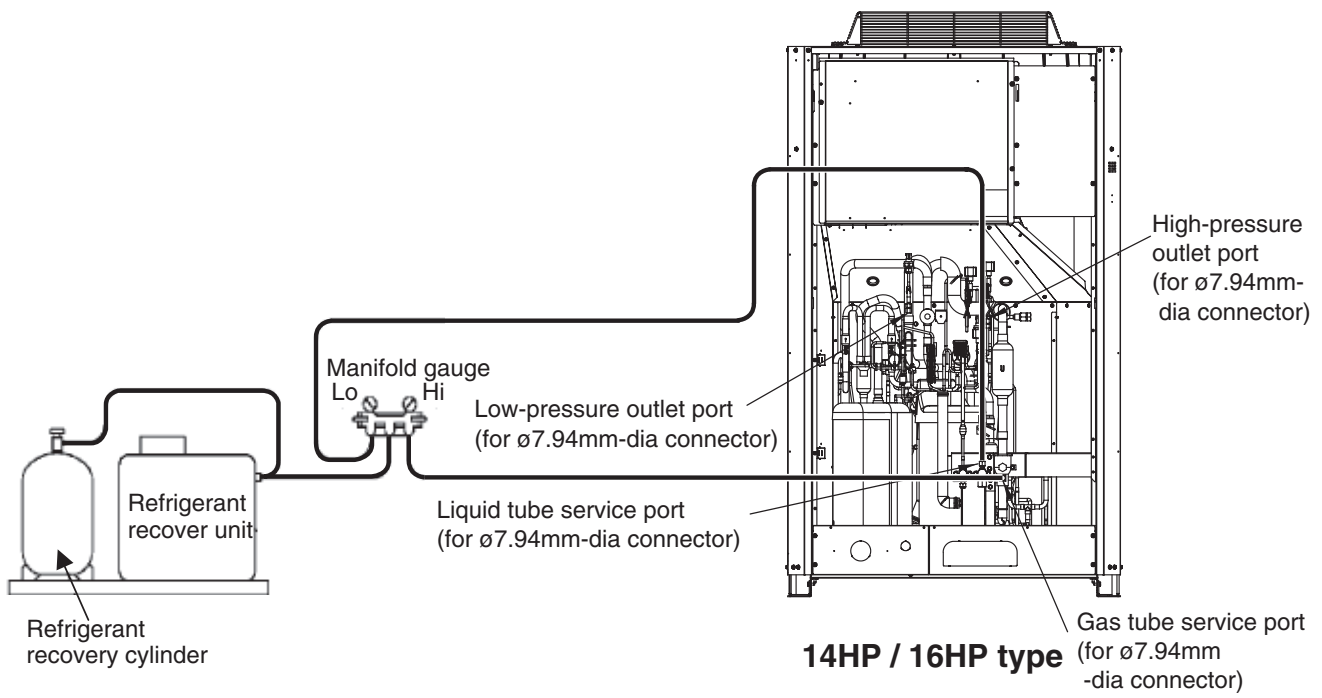

Fig. 5-b

3

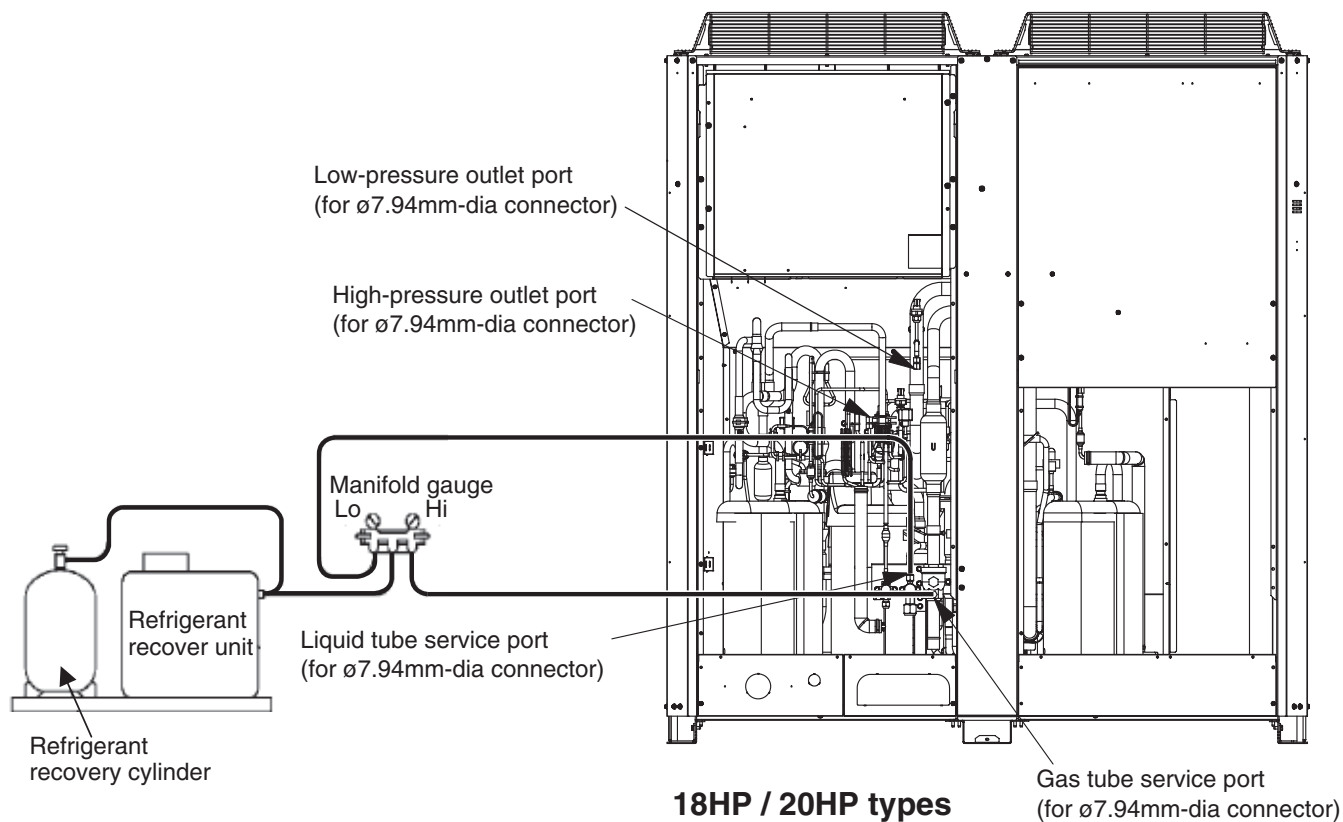

Fig. 5-c

### 4-3. Recovery of Refrigerant from Entire System

- (1) Turn off power to the entire outdoor system.
- (2) Short-circuit the AP (Air Purge) pins (CN050) on the outdoor control PCB of all outdoor units, then supply power to the outdoor units.  
\* By short-circuiting the AP pins and supplying power to the outdoor units, the solenoid valve in each unit is forcibly opened and all remaining refrigerant can be recovered.
- (3) If any unit has encountered a power failure, follow the instructions in “4-1. Refrigerant Recovery Procedures (from Outdoor Units)” and perform refrigerant recovery for the faulty outdoor unit.
- (4) Connect the manifold gauge to the high- and low-pressure outlet ports (Schrader-type valves) on any outdoor unit. (Fig. 5)



**CAUTION**

**Remaining refrigerant may create internal pressure, therefore care should be taken when connecting the hoses.**

- (5) Connect the manifold gauge valves, refrigerant recovery unit, and refrigerant recovery cylinder. Quickly connect each part to prevent air from entering the tubing.
- (6) Check that each service valve of the gas tubes, liquid tube, and the balance tube for the outdoor unit has opened, then perform refrigerant recovery.  
\* If only a single outdoor unit is installed, the balance tube is not used. Therefore, leave this valve closed.

**NOTE**

To determine the completion of refrigerant recovery, follow the instructions that came with the refrigerant recovery unit.

## 5-1. Pressure Check for Leakage of Outdoor Unit

After completing repair of the outdoor unit, carry out the following leakage check.

- (1) Check that all service valves for gas tubes, liquid tube, and balance tube in the repaired outdoor unit (units necessary to carry out the pressurized leak check) are fully closed.
- (2) Connect the manifold gauge valves to the high- and low-pressure outlet ports of the outdoor unit.
- (3) Feed nitrogen gas into the circuit until 3.8 MPa pressure is reached. If it is apparent that the nitrogen gas is not entering the repaired section, interrupt the feeding. Short-circuit the AP pins (CN050) on the outdoor unit control PCB, turn on power to run the outdoor unit, then resume feeding nitrogen.
- (4) Apply soapy water to the repaired part (such as a newly brazed part), and briefly inspect for any leakage. If there are any leaks, bubbles will show on the tubing surface.

\* To continue the air-tight check after the brief leak inspection, turn on power while short-circuiting the AP pins. Again feed nitrogen gas to obtain a system pressure of 3.8 MPa. Then measure both the outdoor ambient temperature and the pressure in the system. Leave the system in this state for 1 full day and night, and again measure the outdoor ambient temperature and pressure (to determine any reduced values). During the inspection, it is recommended that an awning or cover be used to shield the unit in case of rain. If no problem is found, purge all nitrogen from the system.

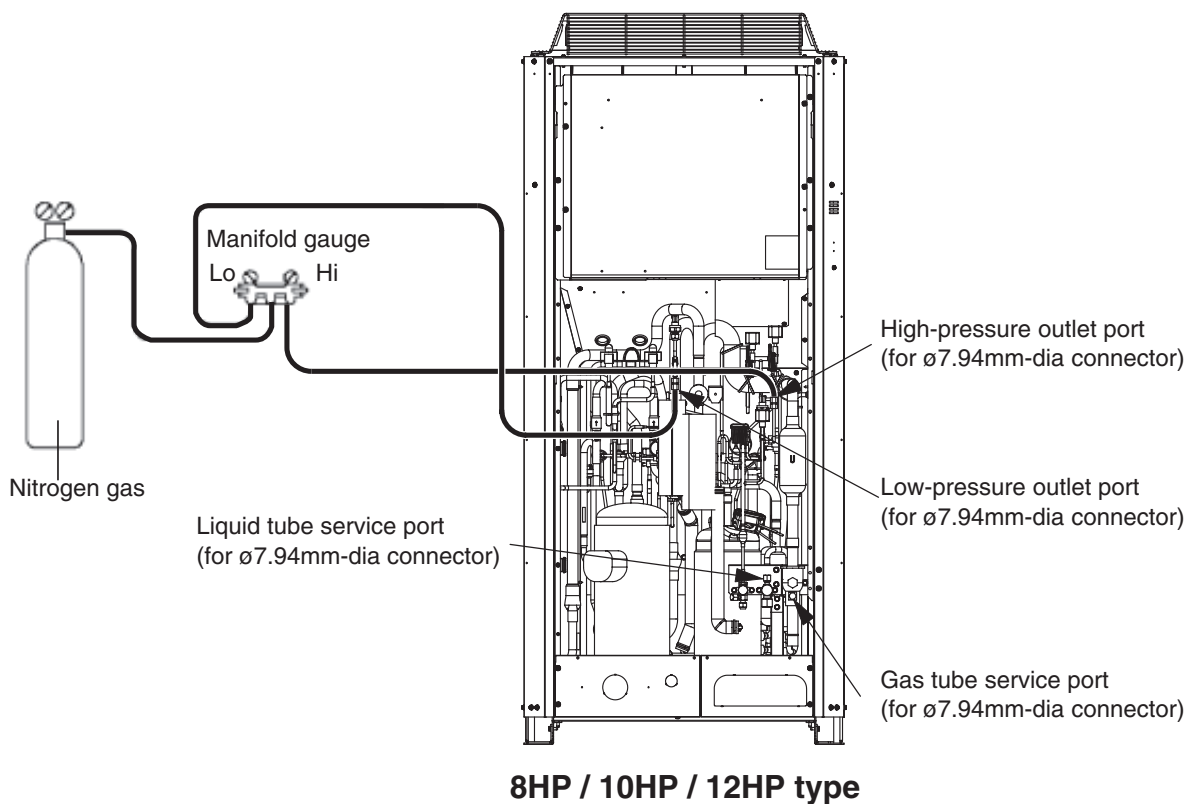

Fig. 6-a

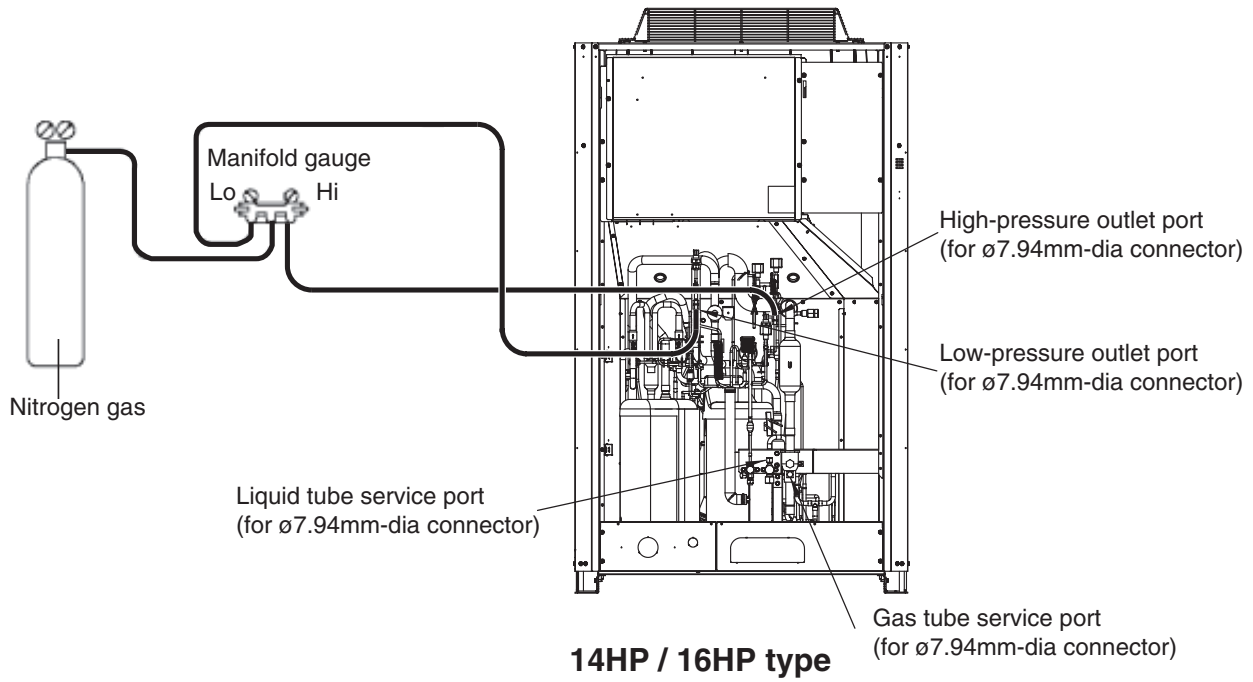

Fig. 6-b

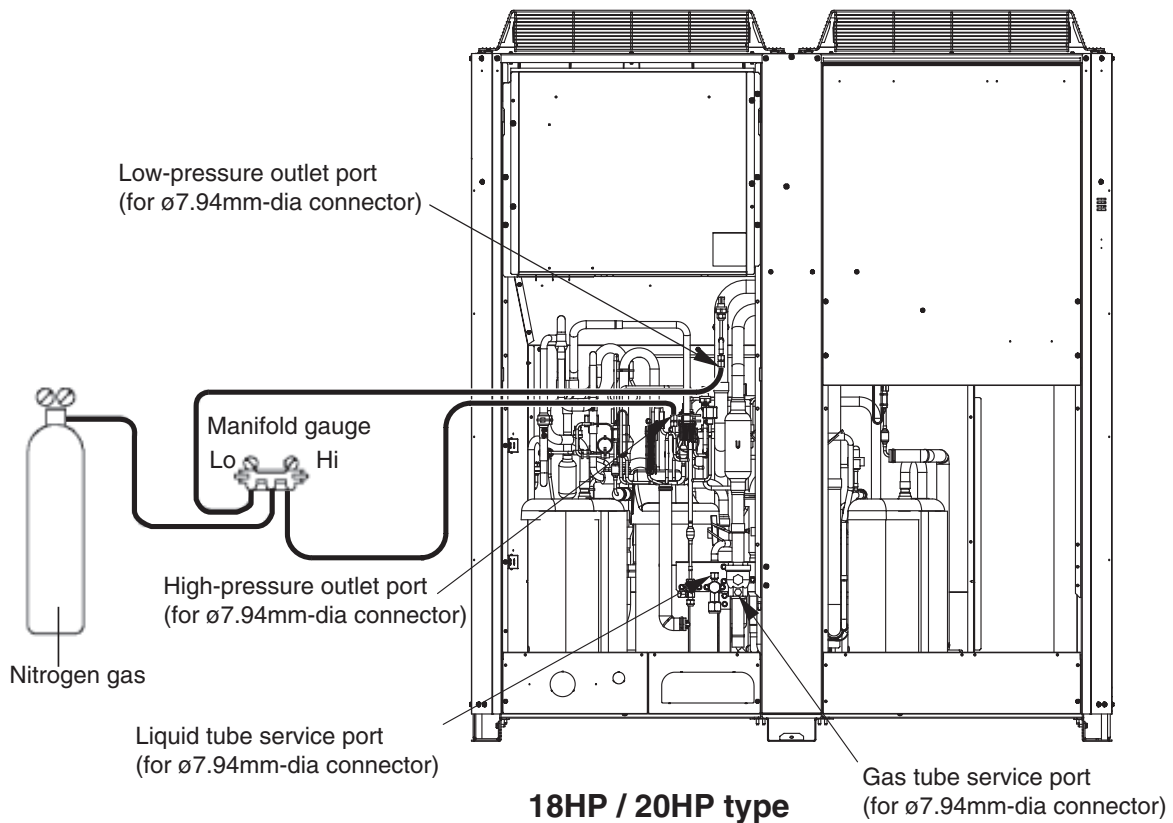

Fig. 6-c

## 5-2. Checking for Leakage in Refrigerant Tubing Between Indoor and Outdoor Units

Refer to the "Installation Instructions" that came with the outdoor unit.

This procedure is carried out to ensure there is no remaining refrigerant or other gases (nitrogen, etc.) in the repaired outdoor unit and tubing.

## 6-1. Evacuating Repaired Outdoor Unit

- (1) Check that each service valve of the gas tubes, liquid tube, and balance tube in the outdoor unit are fully closed.
- (2) Connect the manifold gauge valves to the high-pressure and low-pressure sensor outlets of the outdoor unit.  
(Fig. 7)
- (3) Connect the manifold gauge valves to the vacuum pump.  
\* If the AP pins (CN050) on the outdoor control PCB have already been short-circuited, step (4) is not necessary.
- (4) Turn off power to the repaired outdoor unit and short-circuit the AP (Air Purge) pins on the outdoor control PCB.



**CAUTION**

**By short-circuiting the AP pins and turning on power to the outdoor unit, all electronic valves in the outdoor unit are forcibly opened and any remaining nitrogen gas can be recovered. Failure to perform this procedure may result in nitrogen gas remaining in the refrigerant circuit and causing operating problems. Therefore, never skip this step.**

- (5) Turn the power ON at the outdoor unit where vacuum will be applied. Then run the vacuum pump and continue evacuation until the vacuum condition falls to less than  $-101\text{kPa}$  ( $-755\text{ mmHg}$ ,  $5\text{ Torr}$ ).



**CAUTION**

**To ensure proper evacuation, refer to the operating instructions that came with the vacuum pump.**

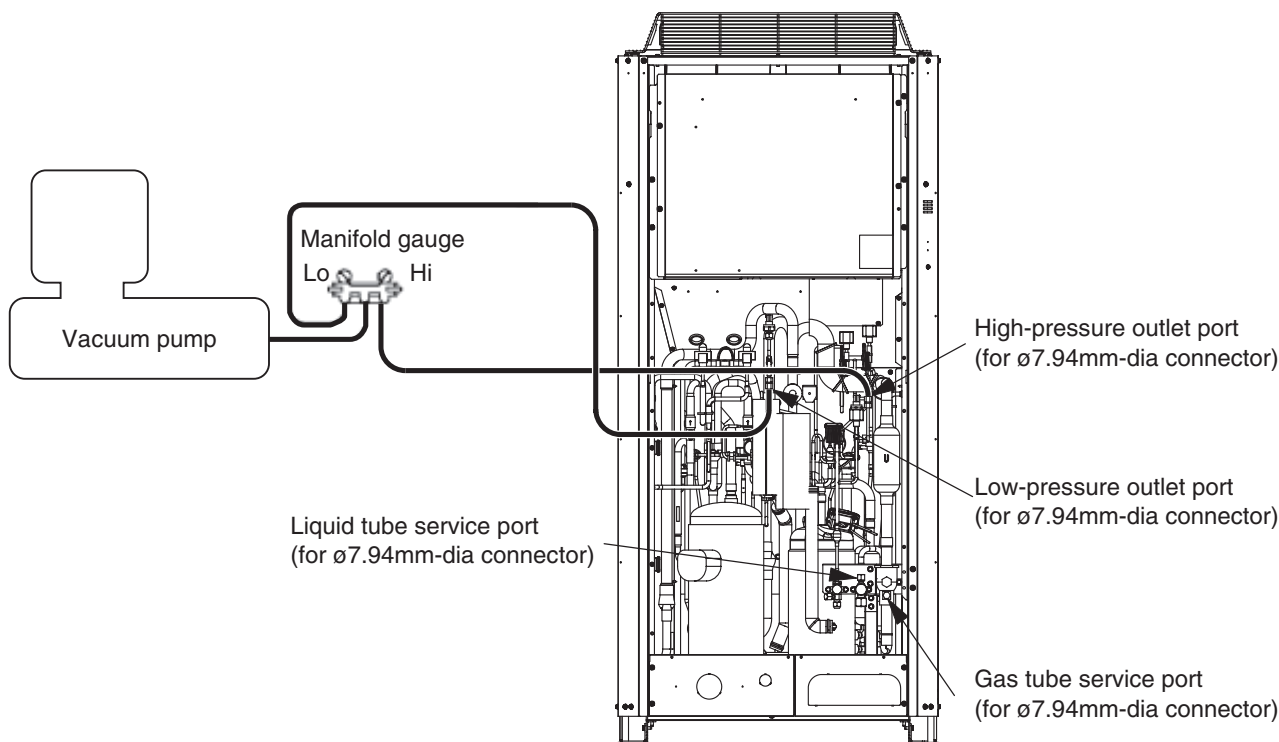

**8HP / 10HP / 12HP type**

**Fig. 7-a**

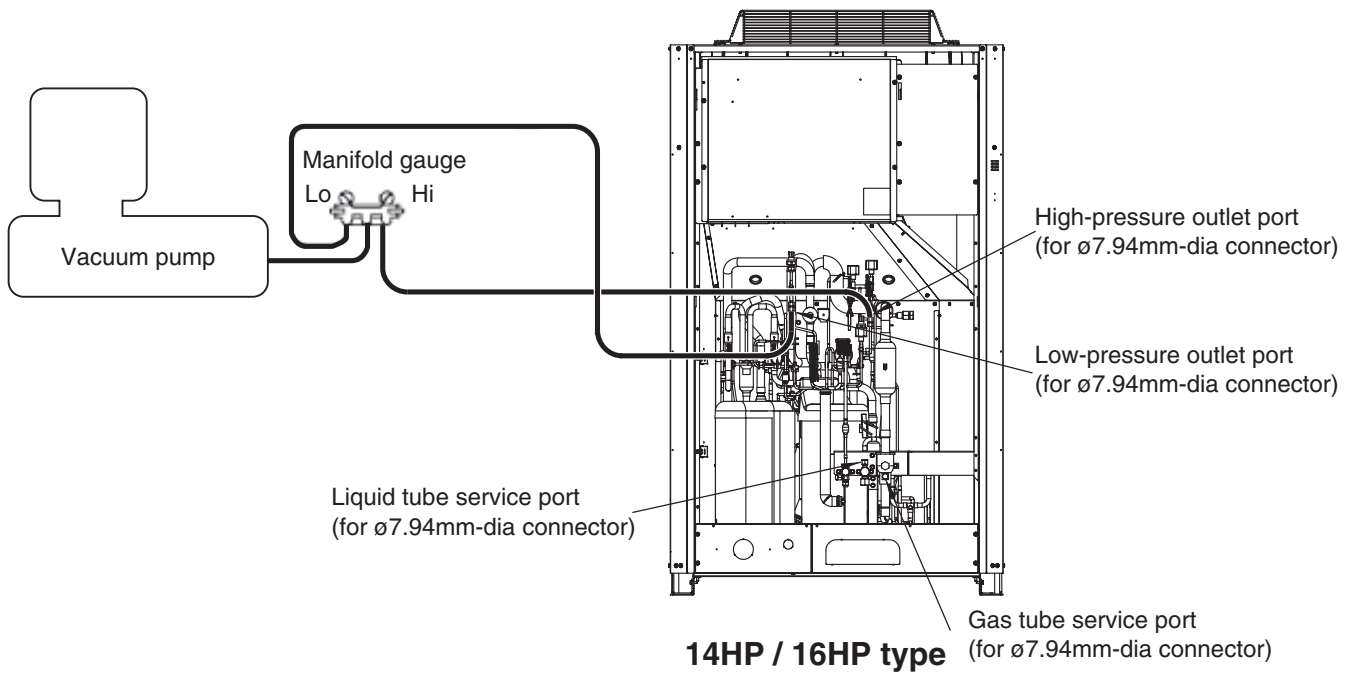

Fig. 7-b

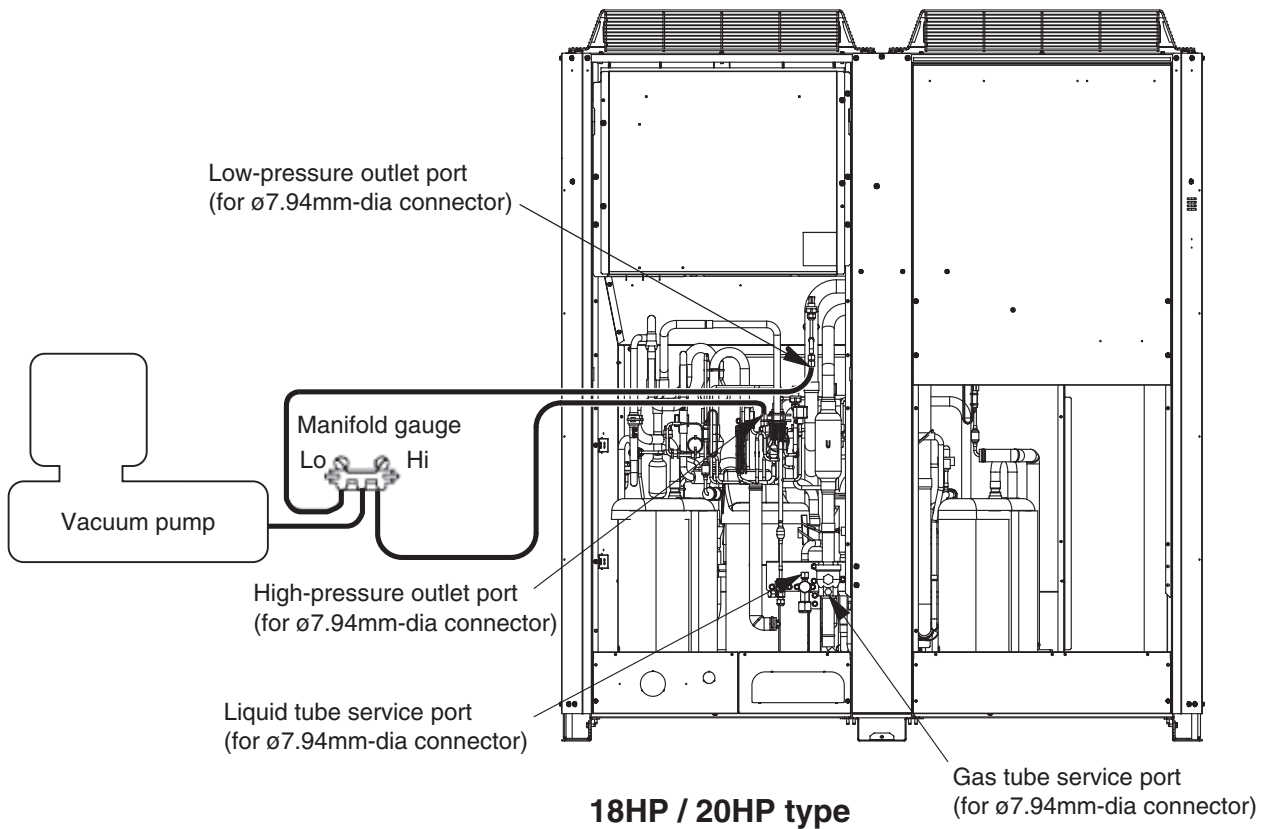

Fig. 7-c

## 6-2. Evacuating Refrigerant Tubing Between Indoor and Outdoor Units

Refer to the "Installation Instructions" that came with the outdoor unit.

## 7-1. If Refrigerant Has Already Been Charged to Outdoor Unit

Be sure to use an exclusive oil-charging tank for charging compressor oil. Prior to charging, carry out vacuum drying inside the tank and take care that no air (in the form of bubbles) is permitted to enter the tank.

The oil charging procedures are given below.

\*The receiver tank used for maintenance may be used as an exclusive oil-charging tank.

When installing the oil-charging tank to the refrigerant system to serve as a safety bypass circuit for refrigerant, connect it to the gas tube service port carefully to avoid releasing refrigerant into the atmosphere.

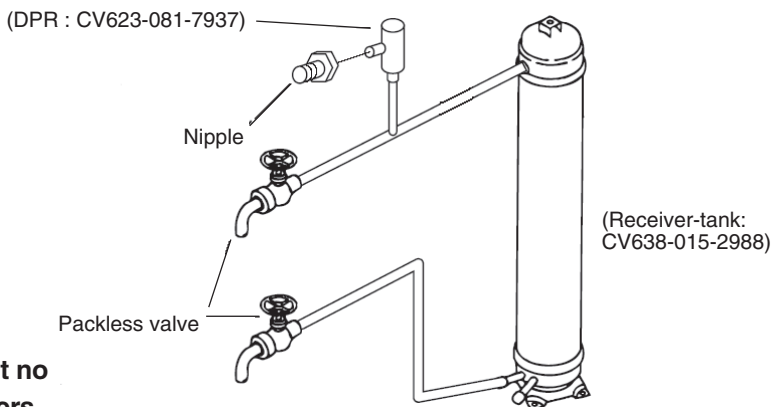

Fig. 8



**CAUTION**

**Perform oil charging work carefully so that no liquid refrigerant enters the charging tank.**

### (1) Evacuation drying in oil-charging tank

With the lower side valve fully closed, open the upper side valve and connect it to the vacuum pump via the manifold gauge valves as shown below. Run the vacuum pump and evacuate the tank until the pressure falls to below  $-101\text{kPa}$  ( $-755\text{mmHg}$ , 5 Torr) for the evacuation drying. After the evacuation drying is finished, fully close the upper valve. Next, fully close the manifold gauge valves and stop the vacuum pump.



**CAUTION**

**To ensure proper evacuation, refer to the operating instructions that came with the vacuum pump.**

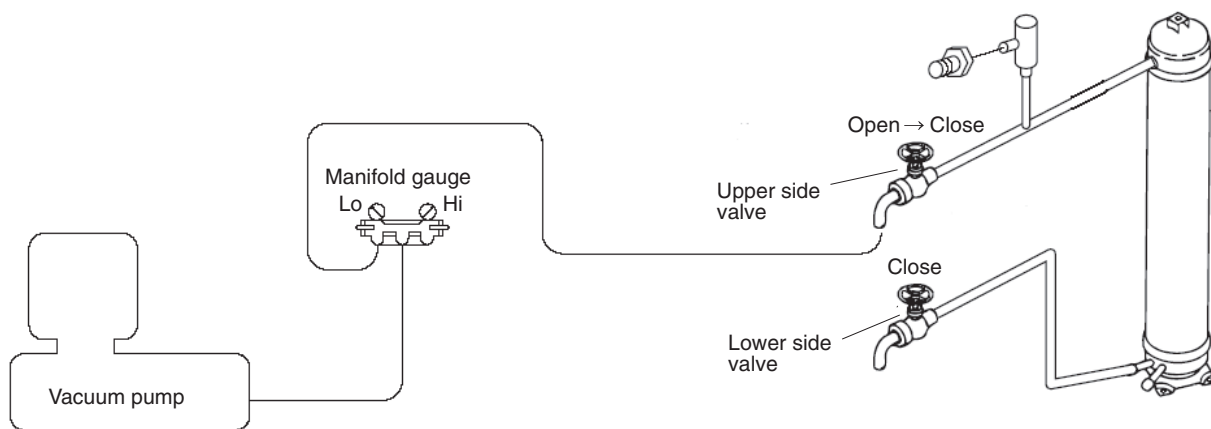

Fig. 9

### (2) Charging compressor oil into oil-charging tank

Connect a piece of pipe to the lower valve and then insert the other end deeply into the bottom of the oil container. Make sure you avoid letting any air be sucked into the tube. Next, run the vacuum pump and open the manifold gauge valves, then open the upper and lower valves to begin charging oil into the charging tank.



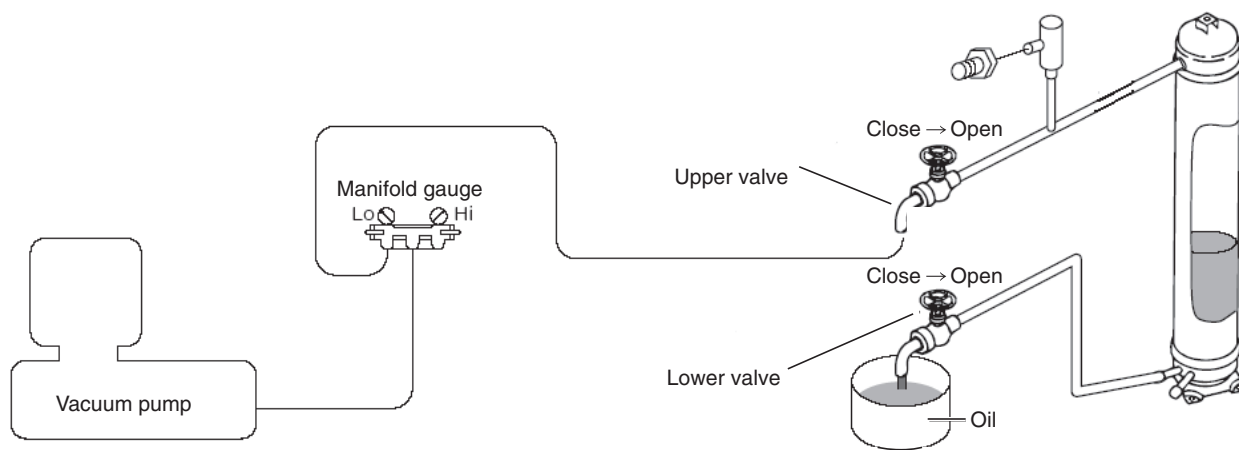

Fig. 10

When the predetermined amount of oil has been charged into the oil-charging tank, immediately close the lower valve. Next, run the vacuum pump until the system pressure reaches lower than  $-101\text{kPa}$  ( $-755\text{mmHg}$ ,  $5\text{Torr}$ ). Close the upper valve and then, stop the vacuum pump.

3



**CAUTION**

**Do this operation quickly because compressor oil easily absorbs moisture from the air.**

(3) Charging compressor oil into outdoor unit

Connect the lower valve to the low-pressure outlet (with Schrader-type push-to-release valve) in the outdoor unit to be oil-charged, and then connect the high-pressure outlet (with push-to-release valve) to the upper valve via the manifold gauge valves (at Hi-pressure gauge side). In addition, connect the gas tube service port (with push-to-release valve) to the DPR (Discharge Pressure Regulator). Carry out the connection work quickly to avoid letting air enter.



**CAUTION**

- The hoses may be subject to internal pressure from the refrigerant inside the outdoor unit. A Schrader-type push-to-release valve is provided at each connection port.
- Since the DPR valve opens at pressures of  $2.5\text{MPa}$  and above, be sure to connect the DPR to the gas tube service port (low-pressure side).

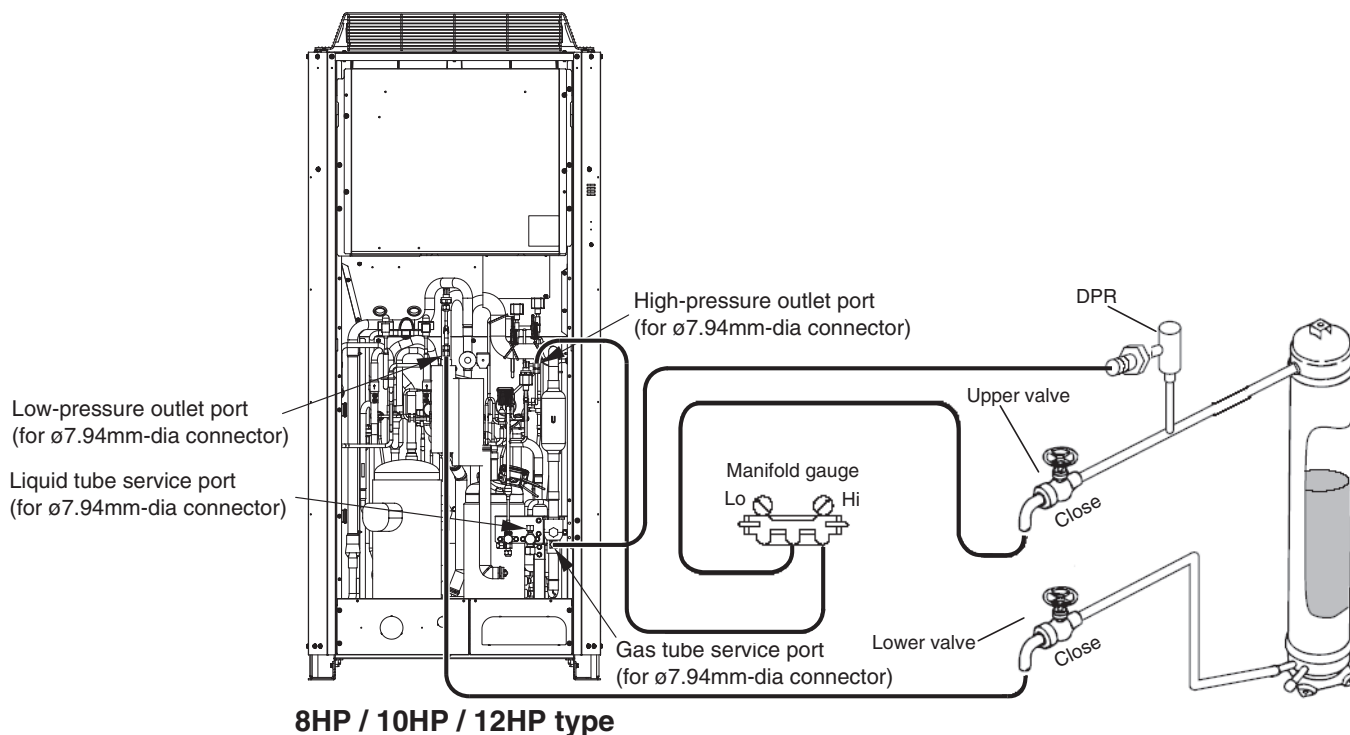

8HP / 10HP / 12HP type

Fig. 11-a

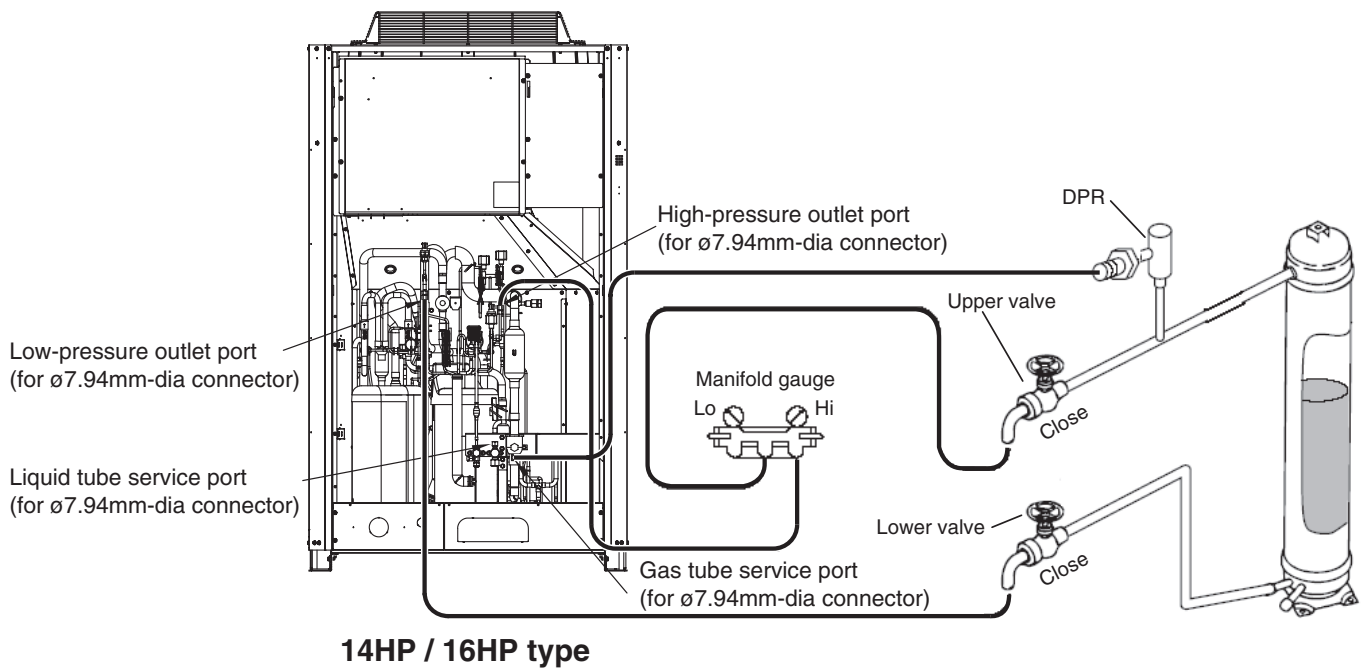

Fig. 11-b

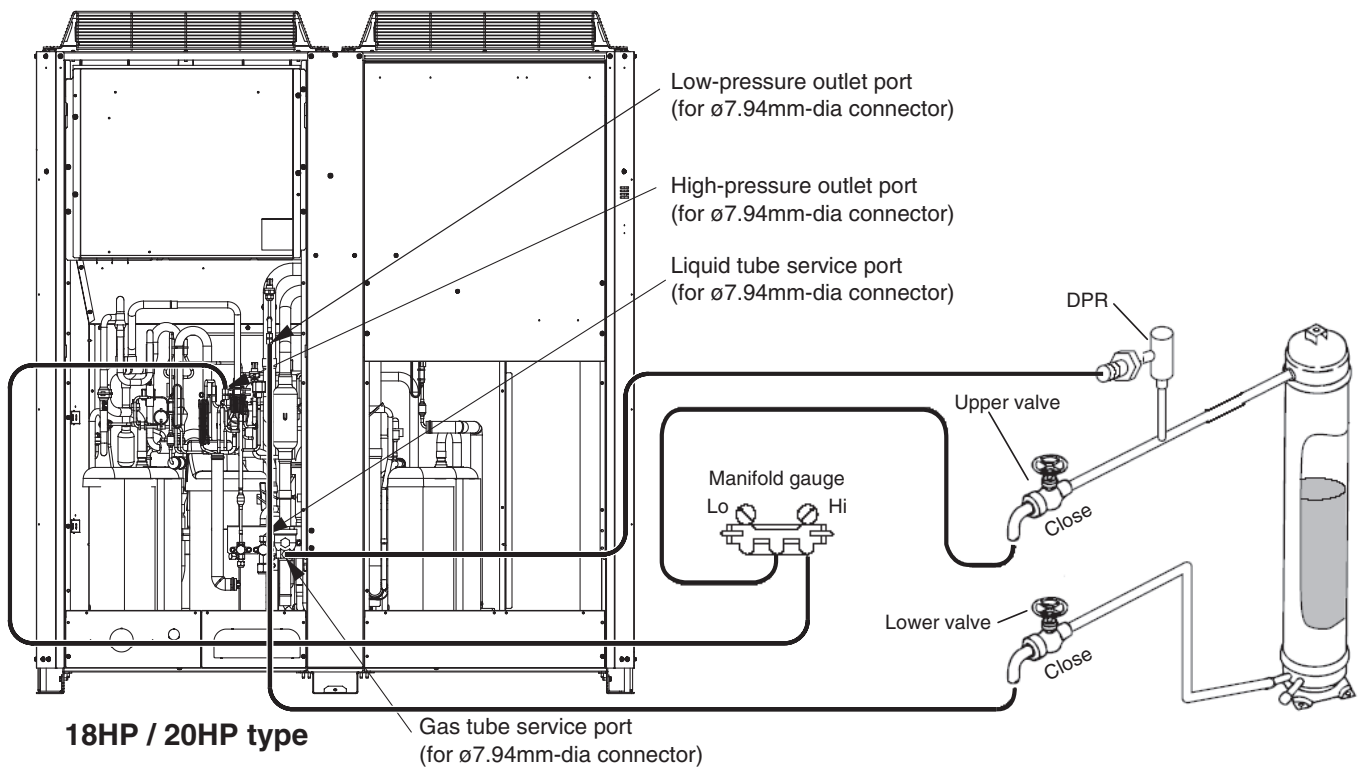

Fig. 11-c

## 7. Charging Compressor Oil

Next follow the instructions in “4-2-1. Cooling operation (for all units)” at the outdoor unit where oil will be charged, and start cooling operation at all units. When the operating conditions have stabilized, perform steps 1, 2, and 3 in sequence and open the valves. When this is done, the refrigerant pressure from operation forces the oil out of the oil charge tank, and oil is charged into the outdoor unit from the low-pressure outlet port. From time to time close the upper valve on the top of the oil charge tank (only this valve) and shake the tank to check the amount of remaining oil.

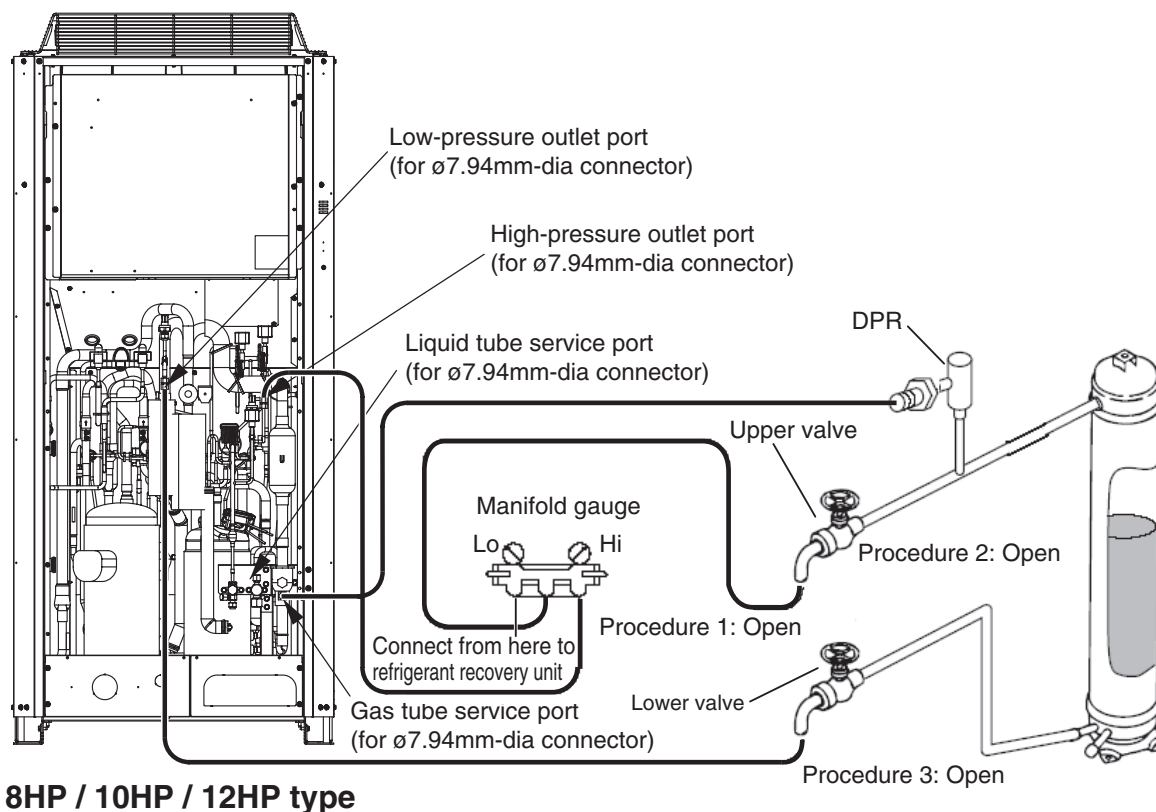

Fig. 12

To terminate the oil charging work, do as follows:

To end the charge process, first close the valve on the high-pressure side of the manifold gauge. Then wait several tens of seconds after the pressure display on the manifold gauge low-pressure gauge stabilizes (in order to equalize the pressure with the low-pressure outlet port and to vaporize the refrigerant in the charge tank). Then perform steps 1 and 3 in sequence and fully close the valves. Finally, connect the refrigerant recovery unit to the Lo-gauge side, shut down all indoor and outdoor units, and then recover the remaining refrigerant in the oil-charging tank, manifold gauge valves, and connecting hoses. Perform these procedures quickly and securely so that no air can enter. After, charge the necessary amount of new refrigerant by referring to the “Installation Instructions” that came with the outdoor unit.

### NOTE

To determine the completion of refrigerant recovery, follow the instructions that came with the refrigerant recovery unit.

### 7-2. If Outdoor Unit Has Not Been Charged with Refrigerant

When a compressor has been replaced or in any other case where the outdoor unit has not been charged with refrigerant, first charge with refrigerant then follow the instructions in “7-1. If Refrigerant Has Already Been Charged to Outdoor Unit” and charge with oil.

Or, alternatively, follow the procedure below.

- (1) Connect a tube to the oil outlet port on the outdoor unit to be charged with oil. Insert the other end of the tube into the oil container.
- (2) Follow the instructions in “6. Evacuating System,” and apply vacuum to the outdoor unit to be charged with oil.  
When this is done, oil is charged into the outdoor unit through the oil outlet port.
- (3) When the unit has been charged with the designated amount of oil, stop the vacuum pump.



**CAUTION**

The oil absorbs moisture readily. This work must be completed quickly.

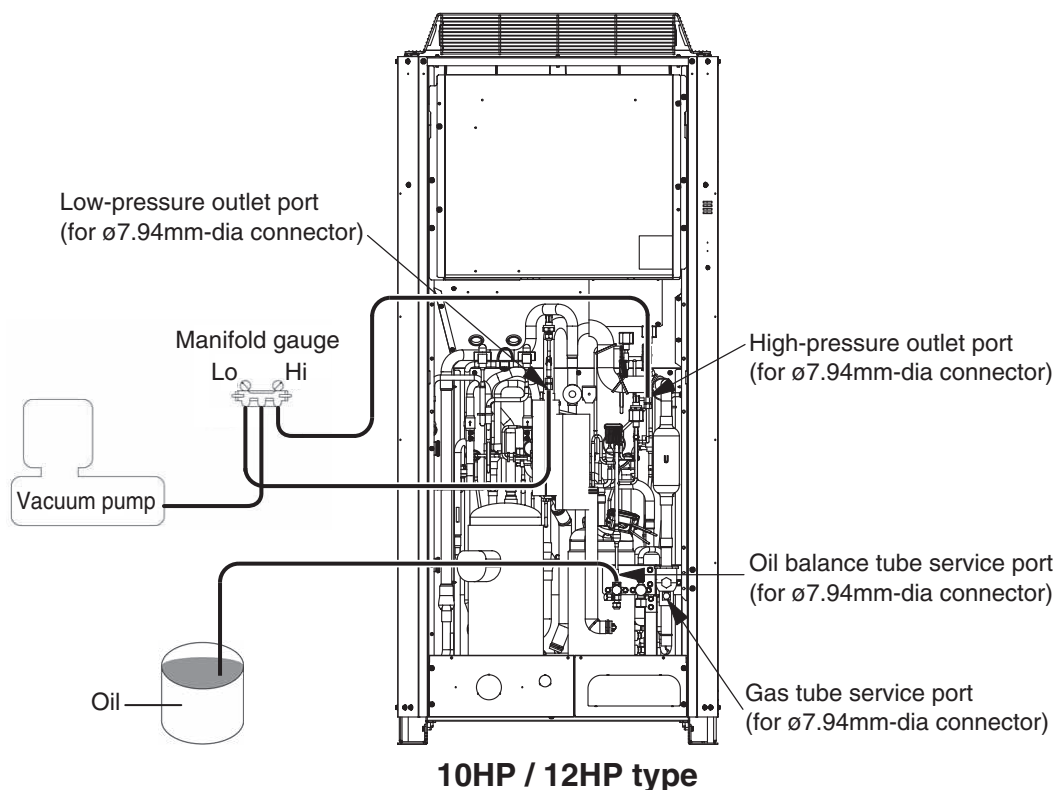

Fig. 13

### 7-3. Charging Additional Compressor Oil (after replacing compressor)

The rated amount of oil is pre-charged in the compressors as given below:

Model name	Compressor model	Q'ty	Pre-charged amount of oil (liters)
U-8ME1E8	C-9RVN393H0S	1	1.9
U-10ME1E8	C-9RVN273H0F	1	1.9
	C-SDN453H8B	1	1.7
U-12ME1E8	C-9RVN273H0F	1	1.9
	C-SDN523H8B	1	1.7
U-14ME1E8	C-9RVN393H0S	1	1.9
	C-SDN453H8B	1	1.7
U-16ME1E8	C-9RVN393H0S	1	1.9
	C-SDN523H8B	1	1.7
U-18ME1E8	C-9RVN393H0S	1	1.9
	C-SDN453H8B	2	1.7
U-20ME1E8	C-9RVN393H0S	1	1.9
	C-SDN523H8B	2	1.7

When replacing a faulty compressor, be sure to first measure the amount of remaining oil in the compressor. Charge additional new oil equal to the difference in the remaining oil and the rated amount as listed above.

For example: Type of replaced compressor: C-SDN453H8B

Remaining oil in the removed compressor: 2.2 l

Additional oil to be charged: 2.2 l (remaining oil in the removed compressor) – 1.7 l (rated oil amount) = 0.5 l

\* If the result is a negative amount (remaining oil in the removed compressor is less than the rated amount), it is not necessary to discharge the extra oil from the system.

For the method used for additional oil charging after compressor replacement, refer to “7-1. If Refrigerant Has Already Been Charged to Outdoor Unit.”

## 8. Pumping Out Refrigerant from Outdoor Unit

Required equipment and tools: Jumper wire with clips, adjustable wrench, set of manifold gauge valves for the refrigerant R410A, refrigerant recovery unit, pre-purged refrigerant cylinder for recovery, flat-head screwdriver, and outdoor unit maintenance remote controller.

This work is performed in order to collect the refrigerant from an outdoor unit where repairs (other than compressor replacement) will be performed into other outdoor units and indoor units, and the refrigerant tubing.

### 8-1. If Remote Controller (CZ-RTC2) is Used for Maintenance of Outdoor Unit

- (1) Refer to "3. Backup Operation" and perform backup operation.
- (2) Connect the manifold gauge valves at the Lo side to the low-pressure outlet port of the outdoor unit to be repaired. Also connect the refrigerant recovery cylinder to any one of the normal outdoor units at the liquid line service port (Schrader-type push-to-release valve). Perform the connection work quickly so that no air is allowed to enter. (Fig. 14)
  - \* Connecting the refrigerant recovery cylinder is done to prevent pressure from rising excessively during backup operation by recovering the refrigerant from the outdoor unit to be repaired.
  - (Measure the weight of the refrigerant and cylinder itself beforehand and provide sufficient safety measures, such as installing a high-pressure cutout in the circuit.)



CAUTION

**The hoses may be subject to internal pressure from the refrigerant inside the outdoor unit. Check that the manifold gauge valves are fully closed beforehand. A Schrader-type push-to-release valve is provided at each connection port.**

- (3) Connect the outdoor unit maintenance remote controller to the RC connector (CN077) (3P) (BLU) on the outdoor unit control PCB of the outdoor unit to be repaired. Then start a test run of all units. (Press and hold the  (CHECK) button for 4 seconds or longer.)
- (4) Use the outdoor unit maintenance remote controller to check the operating status of the indoor units. Check that all units are operating in Heating mode. For details concerning operation of the outdoor unit maintenance remote controller, refer to the "Outdoor unit maintenance remote controller" item. It is also possible to check the operating conditions either in cooling or heating mode by touching the gas tube.
  - Cooling mode: low temperature (20°C or lower)
  - Heating mode: high temperature (60°C or higher)



CAUTION

**The gas tubing becomes hot (60 or higher) in heating. Be careful so as not to be burnt when touching the tubing.**

- (5) Close the suction tube and balance tube on the outdoor unit to be repaired. Then slowly close the liquid tube service valve.
- (6) When the low pressure at the outdoor unit to be repaired reaches 0.5 MPa or below, press the ON/OFF button on the outdoor unit maintenance remote controller to stop all the units. Then immediately fully close the gas tube valve on that outdoor unit.



CAUTION

**While closing the valves, the rise in discharge temperature or another factor may cause a protective device to activate, stopping the operation of the outdoor unit. If this occurs, immediately fully close the gas tube valve on the outdoor unit to be repaired.**

- (7) Connect the high-pressure gauge side of the manifold gauge to the high-pressure outlet port on the outdoor unit to be repaired, and connect the manifold gauge to the refrigerant recovery device. Be sure that no air enters the tubing at this time.

## 8. Pumping Out Refrigerant from Outdoor Unit

- (8) Short-circuit the vacuum application pin on the outdoor unit control PCB of the unit to be repaired. Then turn ON the outdoor unit power.



**CAUTION**

**When the vacuum application pin is short-circuited and the power is turned ON, all solenoid valves in the outdoor unit are forced open, allowing the refrigerant to be recovered from all tubes which are separated by solenoid valves. If this work is not performed, it will not be possible to recover all of the refrigerant at the refrigerant recovery device. Be sure to perform this step.**

- ★ Open both Hi- and Lo-side valves on the manifold gauge valves, and recover the refrigerant remaining in the outdoor unit. After that, measure the amount of recovered refrigerant.

### NOTE

To determine the completion of refrigerant recovery, follow the instructions that came with the refrigerant recovery unit.

### 8-2. If Remote Controller is Not Available for maintenance of Outdoor Unit

- (1) Refer to "3. Backup Operation" and perform backup operation.
- (2) Connect the manifold gauge valves at the Lo side to the low-pressure outlet port of the outdoor unit to be repaired. Also connect the refrigerant recovery cylinder to any one of the normal outdoor units at the liquid line service port (Schrader-type push-to-release valve). Perform the connection work quickly so that no air is allowed to enter. (Fig. 14)
  - \* Connecting the refrigerant recovery cylinder is done to prevent pressure from rising excessively during the backup operation by recovering the refrigerant from the outdoor unit to be repaired. (Measure the weight of the refrigerant and cylinder itself beforehand and provide sufficient safety measures, such as installing a high-pressure cutout in the circuit.)



**CAUTION**

**The hoses may be subject to internal pressure from the refrigerant inside the outdoor unit. Check that the manifold gauge valves are fully closed beforehand. A Schrader-type push-to-release valve is provided at each connection port.**

- (3) Determine the outdoor unit where the unit No. setting (S007)(3P DIP switch)(BLU) on the outdoor unit control PCB is set to No.1.
- (4) Short-circuit the test-run pin (CN048) to start operation.
- (5) Leave the unit running for a while, and then touch the gas tubing with fingers to determine whether the unit is running in cooling or heating mode. If it is in heating, follow the step (6) and later procedures.
  - Cooling : low temperature (20°C or lower)
  - Heating: high temperature (60°C or higher).



**CAUTION**

**The gas tubing becomes hot (60 or higher) in heating mode. Be careful so as not to be burnt when touching the tubing.**

- (6) When the unit is operating in heating mode, release the short-circuit at the test-run pin on the outdoor unit control PCB of the No. 1 unit. Then short-circuit the stop pin (CN053) to stop operation.
- (7) Short-circuit the COOL pin (CN085) on the outdoor unit control PCB of the No. 1 unit.
  - \* Switching of the 4-way valve occurs immediately before operation starts. Therefore it does not change at this time. (Mode change cannot be judged from the sound.)
- (8) Short-circuit the test-run pin (CN048) to start operation, leave the unit running for a while. Touch the gas tubing with fingers to determine whether the unit is running in cooling.

## 8. Pumping Out Refrigerant from Outdoor Unit

(9) Close the gas tube and balance tube on the outdoor unit to be repaired. Then slowly close the liquid tube service valve.

\* When the low pressure at the outdoor unit to be repaired reaches 0.5 MPa or below, pull out the SCT connector (2P) (YEL) (CN061) from the outdoor unit control PCB of that outdoor unit. Then immediately fully close the gas tube valve on that outdoor unit.

\* Pulling out the SCT connector immediately stops all of the outdoor units.



### CAUTION

While closing the valves, the rise in discharge temperature or another factor may cause a protective device to activate, stopping the operation of the outdoor unit. If this occurs, immediately fully close the gas tube valve on the outdoor unit to be repaired.

(10) Connect the high-pressure gauge side of the manifold gauge to the high-pressure outlet port on the outdoor unit to be repaired, and connect the manifold gauge to the refrigerant recovery device. Be sure that no air enters the tubing at this time.

(11) Open both Hi- and Lo-side valves on the manifold gauge valves, and recover the refrigerant remaining in the outdoor unit. After that, measure the amount of recovered refrigerant.

### NOTE

To determine the completion of refrigerant recovery, follow the instructions that came with the refrigerant recovery unit.

3

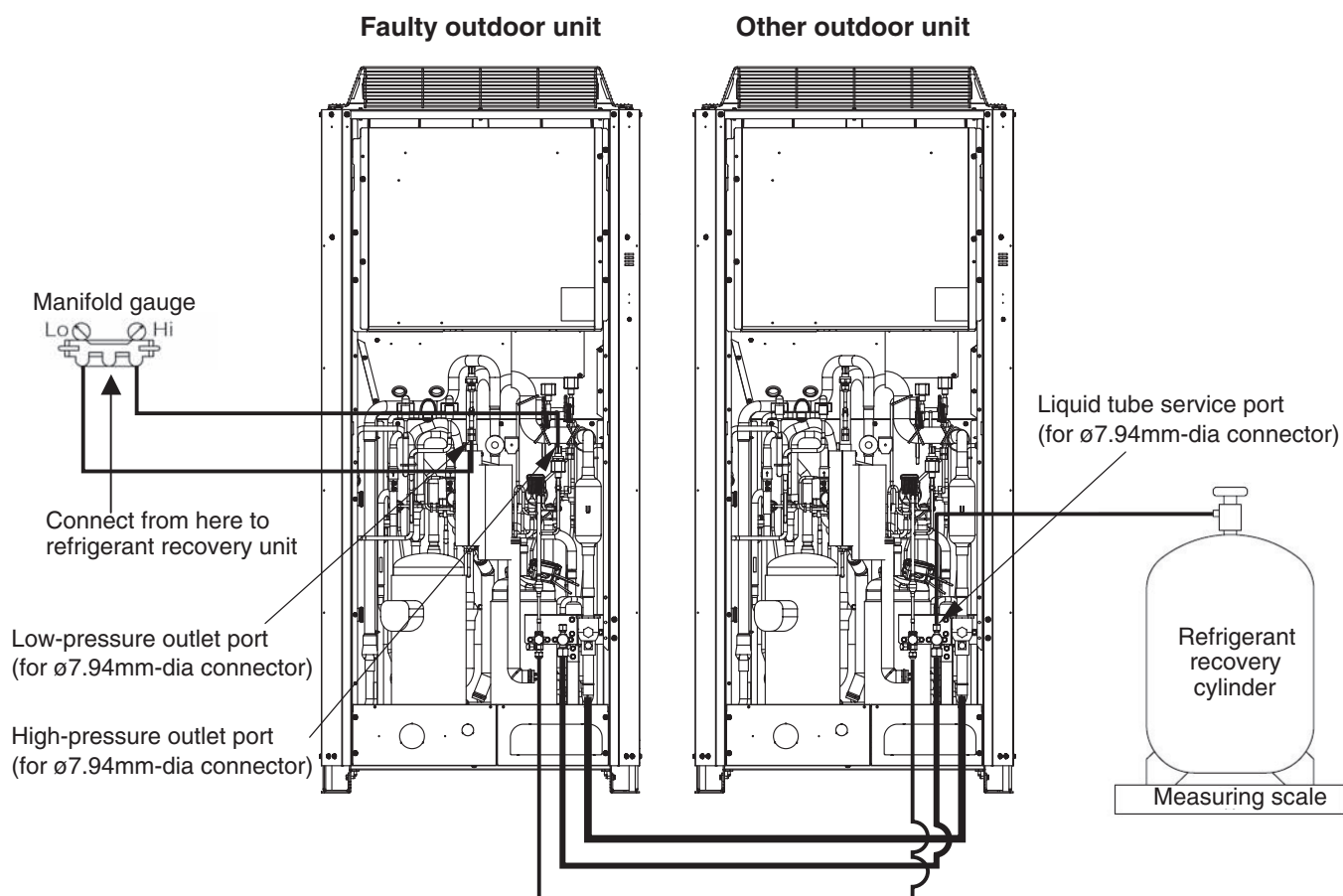

Fig. 14



## 9-1. Compressor Trouble Diagnosis and Check Methods

Generally, compressor failures can be classified into the following categories.

- (1) Mechanical trouble →
  - (A) Locking (intrusion of foreign objects, galling, etc.)
  - (B) Pressure rise failure (damaged valve, seal, bearing, or other component)
  - (C) Noise (damaged stator rotor, valve, or other component)
- (2) Electrical trouble →
  - (A) Coil burning
  - (B) Open circuit
  - (C) Insulation failure
  - (D) Short circuit

Trouble diagnosis is based on the following remote controller displays: [H03] (Compressor 1: INV compressor, center), [H11] [H12] [H13] (Compressor 2: constant-speed compressor 1, left side when viewed from front <not present in model U-8ME1E8(E)> ), [H21] [H22] [H23] (Compressor 3: constant-speed compressor 2, right side when viewed from front (not present in models U-8ME1E8(E), U-10ME1E8(E), U-12ME1E8(E)). A judgment is made based on factors that include the following: coil resistance (varies depending on the compressor), insulation resistance, current, leakage breaker operation, oil and refrigerant fouling, odor, pressure, and noise.

Reference: Insulation resistance (Use a DC 500 V insulation resistance meter and measure the insulation resistance between the electrified and non-electrified parts.)

- (a) Motor → Min. 300 MΩ
- (b) Compressor → Min. 100 MΩ (servicing part)
- (c) Unit → Min. 10 MΩ (This is due to the presence of refrigerant, which decreases the insulation resistance.)

\* Minimum insulation resistance as required by generally accepted requirements is 1 MΩ.

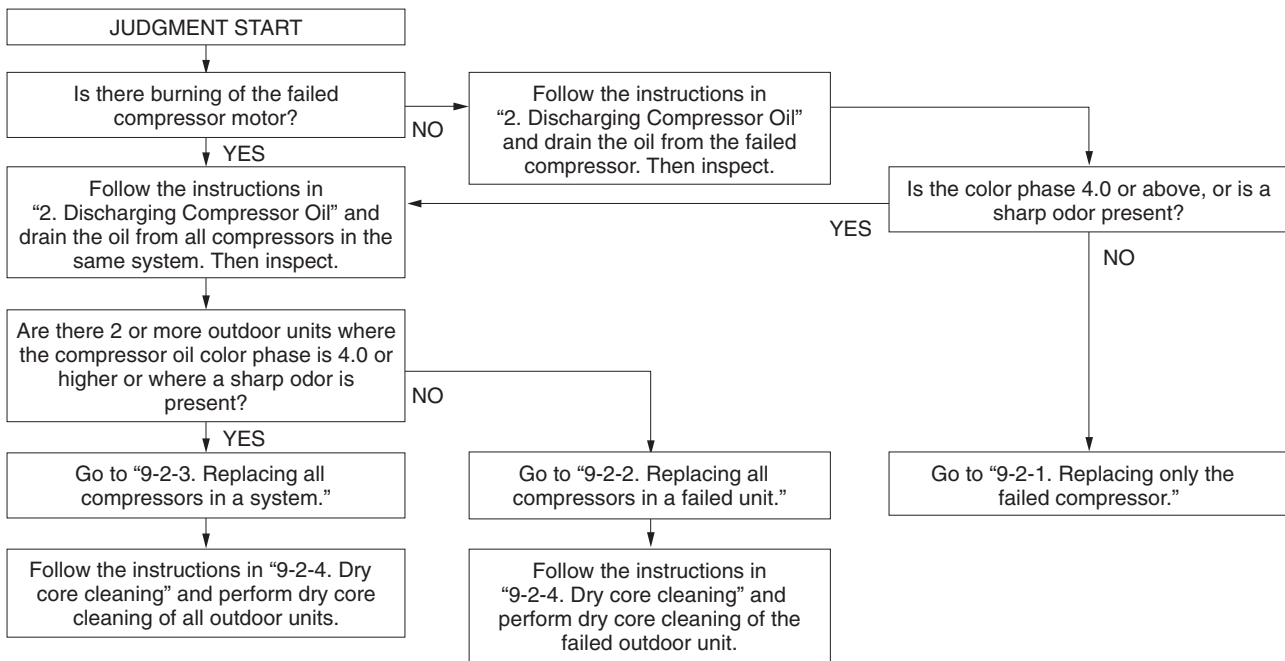

Reference: Symptoms of motor burning

1. Ground fault results in breaker operation.
2. Short circuit results in different coil resistance at different phases.
3. Open circuit



## 9-2. Replacing the Compressor(s)

### 9-2-1. Replacing only the failed compressor

- (1) If backup operation is required, follow the instructions in “3. Backup Operation” and engage backup operation.
- (2) Follow the instructions in “9-3. Removing and Installing Compressor” and replace the failed compressor.
- (3) Fully close the high- and low-pressure gauge valves on the manifold gauge, then stop the vacuum pump.
- (4) Disconnect the manifold gauge from vacuum pump. Connect the manifold gauge to the cylinder where the refrigerant was recovered. At this time, be careful that air does not enter the tubing.
- (5) Open the valve on the refrigerant recovery cylinder and the high-pressure gauge valve on the manifold gauge to charge with refrigerant. At this time, the low-pressure gauge valve on the manifold gauge remains fully closed.



**CAUTION**

**If the recovered refrigerant becomes mixed with another refrigerant or another gas (such as nitrogen or air), do not use the recovered refrigerant for charging. Charge with the designated amount of new refrigerant.**

- (6) When charging has been completed with an amount of new refrigerant equal to the amount of recovered refrigerant, or when charging with the same amount of new refrigerant has not been completed but no more refrigerant will enter the unit, fully close the high-pressure gauge valve on the manifold gauge. Next, turn the power OFF at the repaired outdoor unit, then remove the short circuit at the AP pin (CN050). Finally, fully open all valves on the gas tube, liquid tube, and balance tube.  
However, leave the balance tube fully closed if only a single outdoor unit is installed.
- (7) If backup operation was engaged, follow the instructions in “3. Backup Operation” and perform backup operation recovery.
- (8) If charging with an amount of new refrigerant equal to the amount of recovered refrigerant was not possible, fully close the high-pressure gauge valve on the manifold gauge. Then, while the unit is operating in “4-2-1. Cooling operation (for all units)”, open the low-pressure gauge valve on the manifold gauge and charge with the designated amount of refrigerant.



**CAUTION**

**When charging with liquid refrigerant, add refrigerant a little at a time in order to prevent liquid back-flow.**

- (9) Fully close the low-pressure gauge valves on the manifold gauge, follow the instructions in “7. Charging Compressor Oil,” and charge with oil if necessary.
- (10) Remove the manifold gauge.



**CAUTION**

**The connecting port employs a Schrader-type push-to-release valve. When disconnecting the hose, pressure will be applied from the refrigerant in the outdoor unit.**

**9-2-2. Replacing all compressors in a failed unit**

- (1) Follow the instructions in “2. Discharging Compressor Oil” and drain the oil from the oil separator in the failed unit. Measure the amount of drained oil.
- (2) If backup operation is required, follow the instructions in “3. Backup Operation” and engage backup operation.
- (3) Follow the instructions in “9-3. Removing and Installing Compressors” and replace all compressors in the failed unit.
- (4) Fully close the high- and low-pressure gauge valves on the manifold gauge, then stop the vacuum pump.
- (5) Disconnect the manifold gauge from the vacuum pump. Connect the manifold gauge to the refrigerant cylinder. At this time, be careful that air does not enter the tubing.

**CAUTION**

**Do not reuse the recovered refrigerant. Use a refrigerant cylinder that contains new refrigerant.**

- (6) Open the valve on the refrigerant cylinder, and open the high-pressure gauge valve on the manifold gauge (with the low-pressure gauge valve closed). When charging has been completed with an amount of new refrigerant equal to the amount of recovered refrigerant, or when charging with the same amount of new refrigerant has not been completed but no more refrigerant will enter the unit, fully close the high-pressure gauge valve on the manifold gauge. Next, turn the power OFF at the repaired outdoor unit, then remove the short circuit at the AP pin (CN050). Finally, fully open all valves on the gas tube, liquid tube, and balance tube. However, leave the balance tube fully closed if only a single outdoor unit is installed.
- (7) If backup operation was engaged, follow the instructions in “3. Backup Operation” and perform backup operation recovery.
- (8) If charging with an amount of new refrigerant equal to the amount of recovered refrigerant was not possible, fully close the high-pressure gauge valve on the manifold gauge. Then, while the unit is operating according to “5-2-1. Cooling operation (for all units),” open the low-pressure gauge valve on the manifold gauge and charge with the designated amount of refrigerant.

**CAUTION**

**When charging with liquid refrigerant, add refrigerant a little at a time in order to prevent liquid back-flow.**

- (9) Fully close the low-pressure gauge valves on the manifold gauge, follow the instructions in “7. Charging Compressor Oil,” and charge with the necessary amount of oil. Also add an amount of oil that is equivalent to the amount that was drained from the oil separator.
- (10) Remove the manifold gauge.

**CAUTION**

**The connecting port employs a Schrader-type push-to-release valve. When disconnecting the hose, pressure will be applied from the refrigerant in the outdoor unit.**

- (11) Follow the instructions in “9-2-4. Dry core cleaning” and perform dry core cleaning of the outdoor unit that failed.

## 9-2-3. Replacing all compressors in a system

- (1) Follow the instructions in “2. Discharging Compressor Oil” and drain the oil from the oil separators in all outdoor units. Measure the amount of drained oil.
- (2) Follow the instructions in “9-3. Removing and Installing Compressors” and replace all compressors in the system.
- (3) Follow the instructions in “5. Checking for Leakage After Repair” and check for leaks at all outdoor units and in the tubing.
- (4) Follow the instructions in “6. Evacuating System” and apply vacuum to all outdoor units and tubing.
- (5) Fully close the high- and low-pressure gauge valves on the manifold gauge, then stop the vacuum pump.
- (6) Disconnect the manifold gauge from vacuum pump. Connect the manifold gauge to the refrigerant cylinder. Be especially careful that air does not enter the tubing.



**CAUTION**

**Do not reuse the recovered refrigerant. Use a refrigerant cylinder that contains unused refrigerant.**

- (7) Open the valve on the refrigerant cylinder, and open the high-pressure gauge valve on the manifold gauge. When charging has been completed with an amount of new refrigerant equal to the amount of recovered refrigerant, or when charging with the same amount of new refrigerant has not been completed but no more refrigerant will enter the unit, first turn the power OFF at the repaired outdoor unit, then remove the short circuit at the AP pin (CN050). Then fully open all valves on the gas tube, liquid tube, and balance tube. However, leave the balance tube fully closed if only a single outdoor unit is installed.
- (8) If backup operation was engaged, follow the instructions in “3. Backup Operation” and perform backup operation recovery.
- (9) If charging with an amount of new refrigerant equal to the amount of recovered refrigerant was not possible, fully close the high-pressure gauge valve on the manifold gauge. Then, while the unit is operating in Cooling mode, open the low-pressure gauge valve on the manifold gauge and charge with the designated amount of refrigerant.



**CAUTION**

**When charging with liquid refrigerant, add refrigerant a little at a time in order to prevent liquid back-flow.**

- (10) Fully close the low-pressure gauge valves on the manifold gauge, follow the instructions in “7. Charging Compressor Oil,” and charge with the necessary amount of oil. Also add an amount of oil that is equivalent to the amount that was drained from the oil separators.
- (11) Remove the manifold gauge.



**CAUTION**

**The connecting port employs a Schrader-type valve. When disconnecting the hose, pressure will be applied from the refrigerant in the outdoor unit.**

- (12) Follow the instructions in “9-2-4. Dry core cleaning” and perform dry core cleaning of all outdoor units.

## 9. Compressor

### 9-2-4. Dry core cleaning

If burning or other failures occur repeatedly at compressors within the same system, in many cases the cause is acid, sludge, carbon, or other substances that remain in the refrigeration cycle as the result of insufficient cleaning. If, when the oil is inspected, there is an outdoor unit where the oil color phase is 4.0 or higher, or where a sharp odor is present, carry out all steps below to perform dry core cleaning.

And use the bidirectional dry core for refrigerant R410A.

#### (A) If a ball valve is installed on the outdoor unit

- (1) Refer to “4-2-1. Cooling operation (for all units)” and operate all outdoor units in either Heating or Cooling mode.
- (2) If all units are operated in Cooling mode, close first the liquid tube service valve then the ball valve on all outdoor units where dry cores will be attached.

If all units are operated in Heating mode, close first the ball valve then the liquid tube service valve on all outdoor units where dry cores will be attached.

\* This step is performed in order to expel refrigerant from the tubing between the liquid tube service valve and the ball valve. Approximately 4 – 5 seconds is a sufficient interval between closing each of the 2 valves.

- (3) Press the **ON/OFF** button on the outdoor unit maintenance remote controller to stop the operation of all units.

\* If the outdoor unit maintenance remote controller is not available, use the following method to stop the operation of all units:

Pull out the SCT connector (2P) (YEL) (CN061) from the outdoor unit control PCB of the unit where pump-down is being performed. When the SCT connector is pulled out, alarm F12 (sensor trouble) immediately occurs and all outdoor units stop operating. Be sure that you do NOT grasp the lead wire when pulling out the connector. Removing any other connector may not cause the units to stop. Therefore be sure to pull out only the SCT connector.

- (4) Connect a refrigerant recovery device to the liquid tube service port (Schrader-type valve) of all outdoor units where dry cores will be attached, then recover the refrigerant from the tubing. Be sure that no air enters the tubing at this time.



**CAUTION**

**When the hose is connected, internal pressure is applied by the remaining refrigerant in the inter-unit tubing. The connection port employs a Schrader-type valve. To determine when refrigerant recovery is complete, follow the instructions in the instruction manual of the refrigerant recovery device.**

- (5) As shown in Fig. 15, disconnect the tube that runs from the liquid tube valve to the ball valve on all outdoor units where dry cores will be attached. Then attach the dry cores.
- (6) At all outdoor units where dry cores are attached, pressurize with 3.8 MPa of nitrogen from the liquid tube service port and check for leaks.
- (7) After evacuating all nitrogen gas from the tubing, apply vacuum from the liquid tube service port to all outdoor units where dry cores are attached until the pressure is  $-101\text{kPa}$  ( $-755\text{ mm Hg}$ , 5 Torr) or less.
- (8) Fully open the liquid tube valve and ball valve on all outdoor units where dry cores are attached.
- (9) Operate all outdoor units for approximately 3 hours (in either Heating or Cooling mode).
- (10) Follow the above procedure, and replace all dry cores with new dry cores.
- (11) Operate all outdoor units for approximately 20 minutes (in either Heating or Cooling mode).
- (12) Follow the instructions in “2. Discharging Compressor Oil” and drain a small amount of the oil from the oil separators of all outdoor units where dry cores are attached. Check the color phase, odor, and other characteristics.
- (13) If the results show that dry core cleaning is still necessary (for example, a color phase of 4.0 or higher)\*, return to Step 11 and repeat until the results are normal (including a color phase of 3.5 or less)\*.

\* Color sample sheet for degree of stain



**CAUTION**

**Perform another dry core replacement after approximately 30 hours of system operation.**

- (14) Perform steps (1) – (4), and remove all dry cores. Then connect the tubing between the liquid (narrow) tube valves and the ball valves.
- (15) At all outdoor units where dry cores were removed, pressurize with 3.8 MPa of nitrogen from the liquid tube service port and check for leaks.

- (16) After evacuating all nitrogen gas from the tubing, apply vacuum to all outdoor units where dry cores were removed until the pressure is  $-101\text{kPa}$  ( $-755\text{ mm Hg}$ ,  $5\text{ Torr}$ ) or less.
- (17) **INSTALLATION:** Refer to the "Information for the Person in Charge of Installation" items. Charge with an amount of refrigerant equal to the amount that was recovered.

**(B) If a ball valve is not installed on the outdoor unit**

- (1) Refer to "4-2-3. Refrigerant recovery procedures (2) : Indoor unit with no ball valve equipped." Perform pump down of the refrigerant from all indoor units and inter-unit tubing to the outdoor unit side.
- (2) Cut the liquid (narrow) tube at all outdoor units where dry cores will be attached, then attach the dry cores and ball valves as shown in Fig. 15.
- (3) For the next steps, refer to (6) – (17) in **(A)** on the previous page.

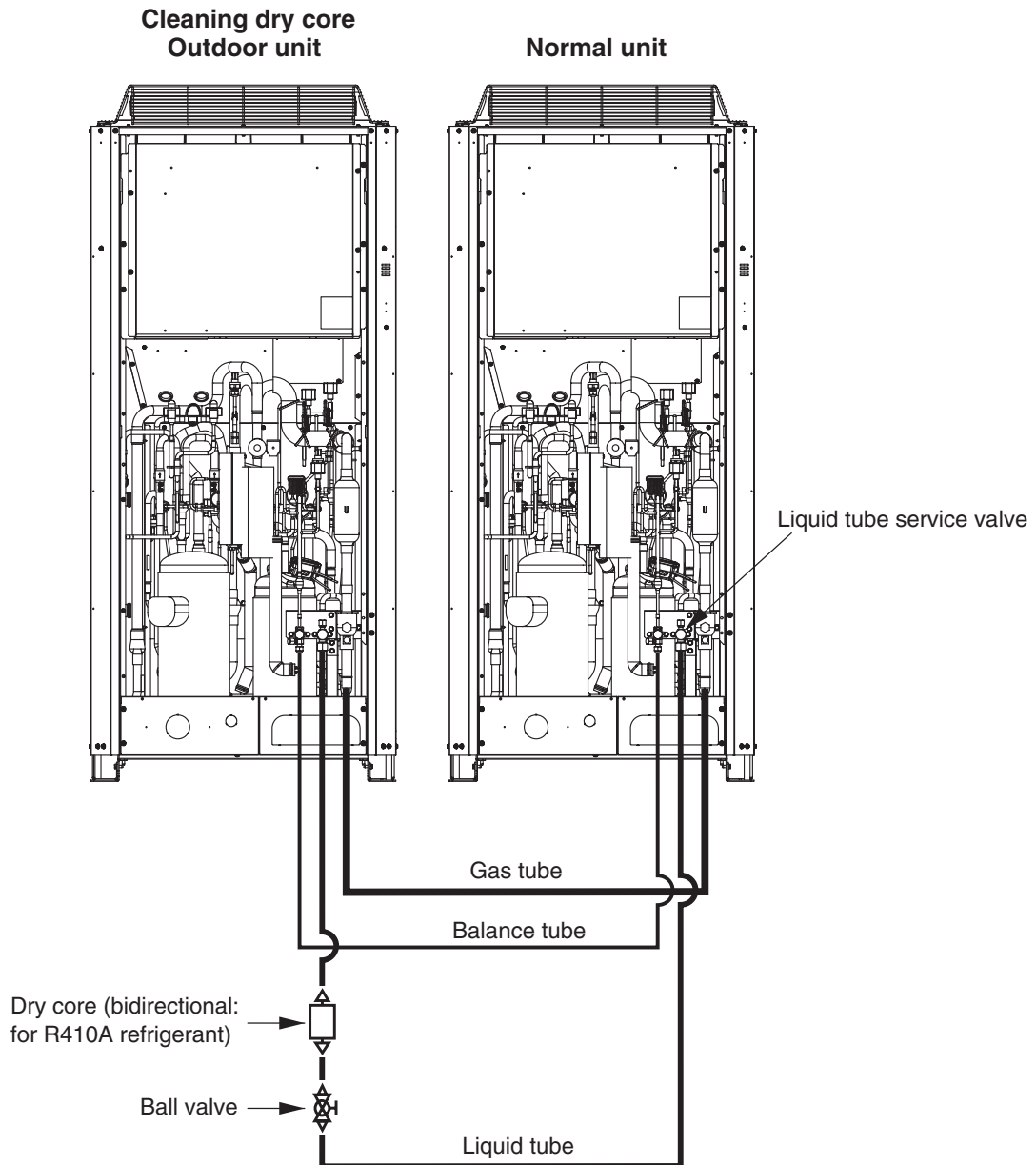

Fig. 15

## 9-3. Removing and Installing Compressors

When removing and installing compressors, use sufficient caution to ensure that moisture or other substances do not enter the refrigerant tubing system.

### 9-3-1. Replacing compressors

#### (A) Replacing the inverter compressor (For all models)

##### ■ Removal

- (1) Connect a manifold gauge to the high- and low-pressure outlet ports at the outdoor unit where the compressor will be replaced. Connect the manifold gauge to a nitrogen cylinder and perform nitrogen gas replacement in the outdoor unit tubings.
- (2) Remove the panels and the corresponding parts from the outdoor unit where the compressor will be replaced.
- (3) Remove the cap and acoustic material that surrounds the compressor

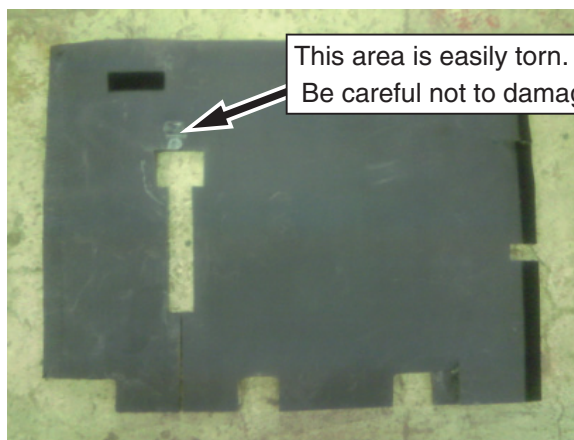

- (4) Remove the cap at the compressor terminal plate. Disconnect the power cable.
- (5) Remove the crankcase heater.
- (6) Disconnect the tube-with-flare-nut using wrenches. At this time, cover the tube in place with waste cloth while watching out for oil leaks. Then cap the disconnected tube and mount the flare nut on the compressor. Tighten the flare nut with a seal bonnet(1/4") in it.

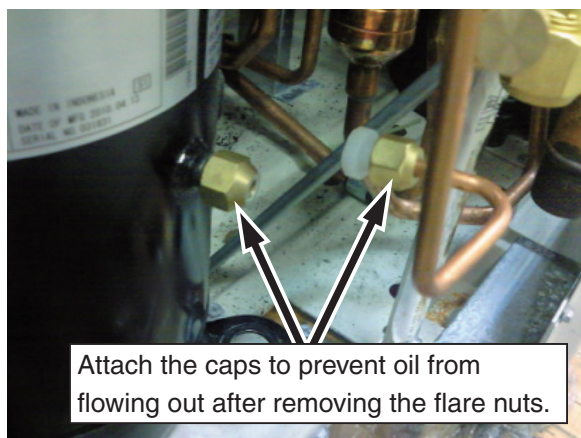

Oil may flow out. Attach the caps promptly after removing the flare nuts.



(7) Remove the 3 bolts, and remove the washers and rubber washers.

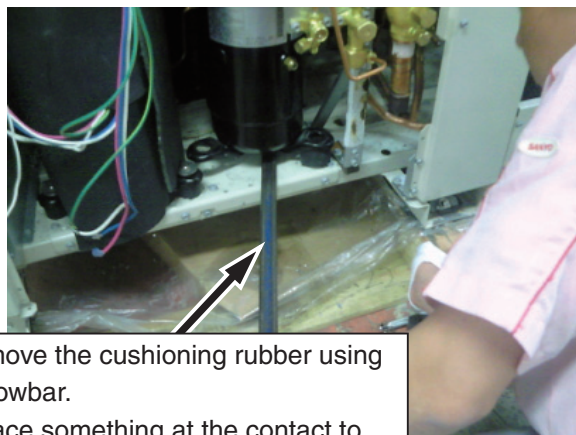
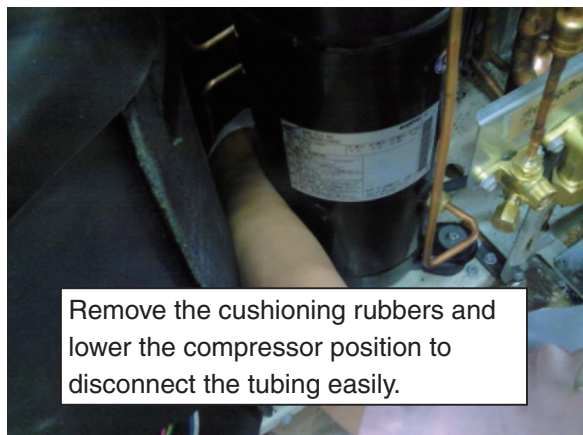

### NOTE

If oil remaining in the compressor reaches the equalized oil level, oil will come pouring out when the tube-with-flare-nut is removed.

3



### CAUTION

Protect the sensors and the surrounding plates, rubber, lead wires, clamps, and other items. Remove the discharge sensor.

(8) Disconnect the discharge tubing.

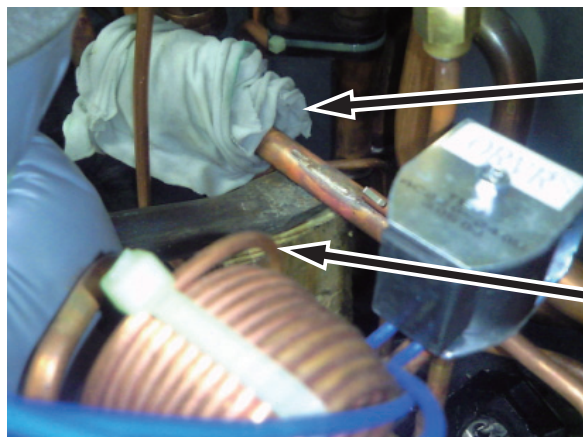

Be sure to remove the thermistor.  
Cover the vibration-proof material with wet cloth.

First, insert something between the compressor and discharge tubing to protect from damage. Then, take up the discharge tubing using a crowbar as a lever.

(9) Disconnect the suction tubing.

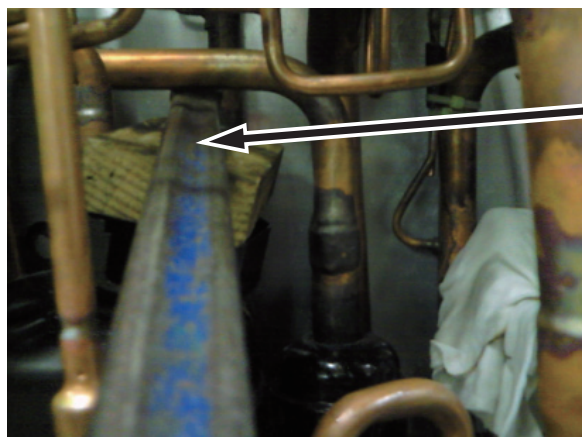

First, insert something between the compressor and suction tubing to protect from damage. Then, take up the suction tubing using a crowbar as a lever.

(10) Pull the compressor toward you.

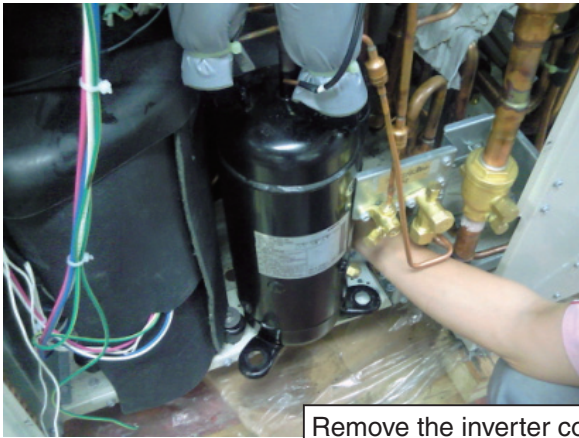

Remove the inverter compressor from the space between the AC1 compressor and service valves. Be careful not to damage cross oil tubing.

### ■ Installation

- (1) Remove the rubber stopper and tube cap (brazed) from the new compressor.
- (2) Install the crankcase heater onto the new compressor.
- (3) Place the 1 piece of cushioning rubber in the designated positions on the compressor.

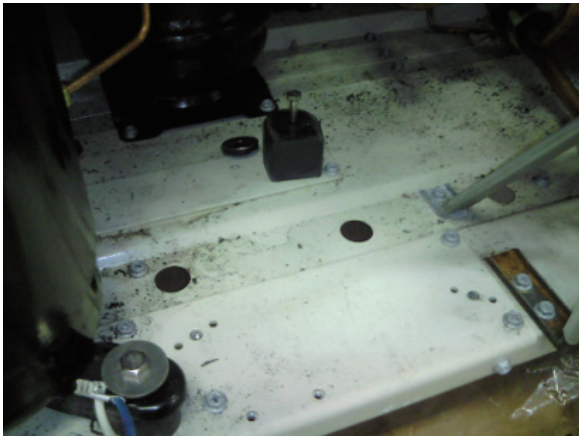

First, temporarily fix the cushioning rubber and bolt in the back. Then, place the compressor.

(4) Place the new compressor.



After the position in the back is fixed, adjust the two positions in front using a crowbar.  
\* Place something at the contact to protect bottom plate coating from damage.



**CAUTION**

When setting the compressor into the unit, be careful not to cause any abnormal deformation of the tube-with-flare-nut.



- (5) Place the remaining cushioning rubber onto the new compressor.
- (6) Anchor the 3 compressor legs using the bolts, washers, and rubber washers.
- (7) Remove the flare nut from the new compressor, and connect the tube-with-flare-nut.
- (8) Shape the tubes and insert them at the 2 brazing locations.
- (9) Connect a manifold gauge to the high- and low-pressure outlet ports at the outdoor unit where the compressor was replaced. Connect the manifold gauge to a nitrogen cylinder and perform nitrogen gas replacement.
- (10) Perform copper brazing at the 2 brazing locations.
- (11) Follow the instructions in "5. Checking for Leakage After Repair" and check for leaks at the outdoor unit where the compressor was replaced.



**CAUTION**

**At this time, also check for leaks at the flare nut connection on the tube-with-flare-nut.**

- (12) Re-install the acoustic material.



Insert the material from this position. It is easier to attach it.

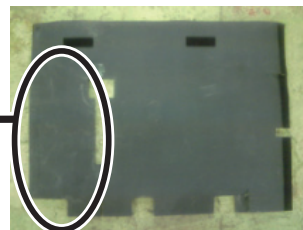

Be careful not to damage the acoustic material while attaching it.



**CAUTION**

**Be sure to check for looseness of the power terminal connection at the compressor terminal plate, and to check by pulling vertically on the connections. If the terminals become disconnected easily, replace the wiring Assy.**

- (13) Follow the instructions in "6. Evacuating System" and apply vacuum to the outdoor unit where the compressor was replaced.

## (B) Replacing the constant-speed compressor 1 (For models U-10ME1E8(E) ~ U-16ME1E8(E))

### ■ Removal

- (1) Connect the manifold gauge to the high- and low-pressure outlet ports at the outdoor unit where the compressor will be replaced. Connect the manifold gauge to a nitrogen cylinder and perform nitrogen gas replacement.
- (2) Remove the panels and the corresponding parts from the outdoor unit where the compressor will be replaced.
- (3) Remove the cap and acoustic material that surrounds the compressor.

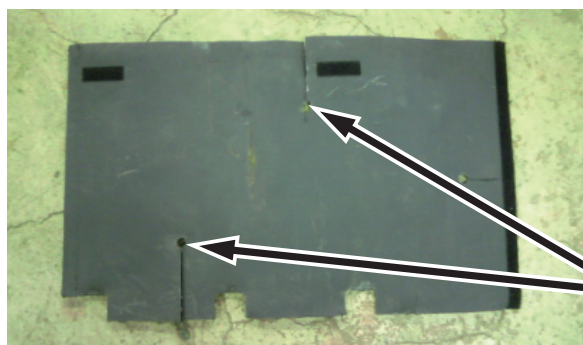

These areas are easily torn. Be careful not to damage.

- (4) Remove the cap at the compressor terminal plate. Disconnect the power cable.
- (5) Remove the crankcase heater.
- (6) Disconnect the tube-with-flare-nut using wrenches. At this time, cover the tube in place with waste cloth while watching out for oil leaks. Then cap the disconnected tube and mount the flare nut on the compressor. Tighten the flare nut with a seal bonnet(1/4") in it.

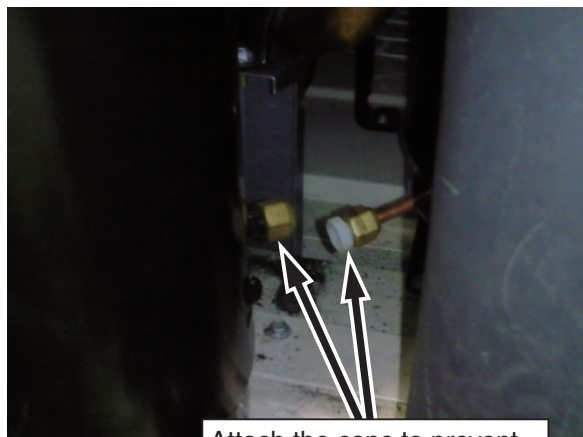

Attach the caps to prevent oil from flowing out after removing the flare nuts.

Oil may flow out. Attach the caps promptly after removing the flare nuts.

3

- (7) Remove the bolts(3 locations), washers, and spacers.  
\* Use a crowbar to remove the cushioning rubbers just like inverter compressor removal procedure.



**CAUTION**

- **Protect the sensors and surrounding plates, rubber, lead wires, clamps, and other items.**  
**Pay particular attention to protection of the oil equalizer tube connector parts, and removal of the discharge sensor.**  
**An O-ring is mounted inside the oil equalizer tube connector parts. It must be protected and do not lose it.**

- (8) Disconnect the discharge tubing.  
\* Pull up the discharge tubing holding it with wet cloth.
- (9) Disconnect the suction tubing.

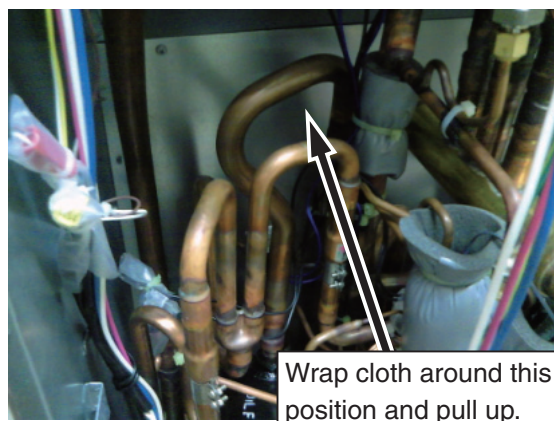

Wrap cloth around this position and pull up.

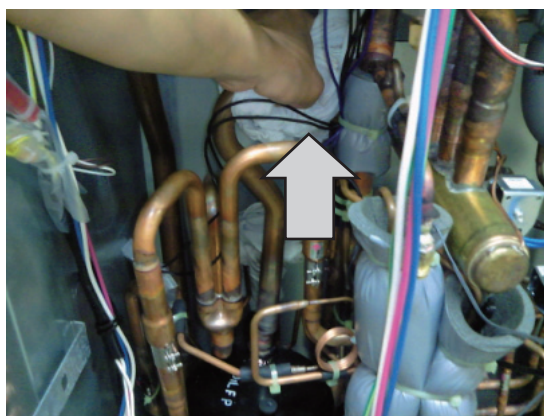

- (10) Pull the compressor toward you.

## ■ Installation

- (1) Remove the rubber stopper and tube cap (brazed) from the new compressor.
- (2) Install the crankcase heater onto the new compressor.
- (3) Temporary mount 2 cushion rubbers with bolts at the position in front.  
Set up the leg of the the new compressor onto the 2 cushion rubbers.
- (4) Set the remaining cushioning rubber beneath the new compressor leg.
- (5) Anchor the 3 com-pressor legs using the bolts, washers, and rubber washers.

Section A of cushioning rubber

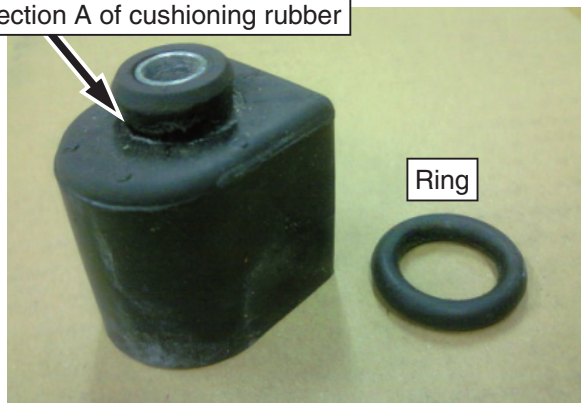

Insert A of the cushioning rubber securely to the leg of the compressor when attaching the bolt. Then attach the ring.  
\* If A is not inserted properly, it may damage the tubing.

3

- (6) Connect the manifold gauge to the high- and low-pressure outlet ports at the outdoor unit where the compressor was replaced. Connect the manifold gauge to a nitrogen cylinder and perform nitrogen gas replacement.
- (7) Remove the flare nut from the new compressor, and connect the tube-with-flare-nut.
- (8) Perform copper brazing at the 3 brazing locations.



**CAUTION**

**In the same way as during removal, pay particular attention to protection of the oil equalizing tube connector parts.**

**An O-ring is mounted inside the oil equalizer tube connector parts. It must be protected and do not lose it.**

- (9) Follow the instructions in “5. Checking for Leakage After Repair” and check for leaks at the outdoor unit where the compressor was replaced.
- (10) Re-install the cap and acoustic material.



**CAUTION**

**Be sure to check for looseness of the power terminal connection at the compressor terminal plate, and to check by pulling vertically on the connections. If the terminals become disconnected easily, replace the wiring Assy.**

- (11) Follow the instructions in “6. Evacuating System” and apply vacuum to the outdoor unit where the compressor was replaced.

## (C) Replacing the constant-speed compressor 1 (For models U-18ME1E8(E), U-20ME1E8(E))

### ■ Removal

- (1) Connect the manifold gauge to the high- and low-pressure outlet ports at the outdoor unit where the compressor will be replaced. Connect the manifold gauge to a nitrogen cylinder and perform nitrogen gas replacement.
- (2) Remove the panels and the corresponding parts from the outdoor unit where the compressor will be replaced.
- (3) Remove the cap and acoustic material that surrounds the compressor.

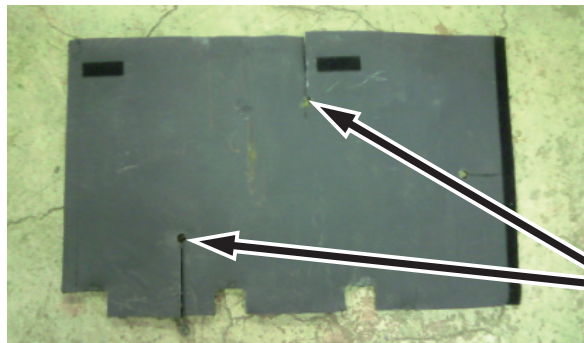

These areas are easily torn. Be careful not to damage.

- (4) Remove the cap at the compressor terminal plate. Disconnect the power cable.
- (5) Remove the crankcase heater.
- (6) Disconnect the tube-with-flare-nut using wrenches. At this time, cover the tube in place with waste cloth while watching out for oil leaks. Then cap the disconnected tube and mount the flare nut on the compressor. Tighten the flare nut with a seal bonnet(1/4") in it.

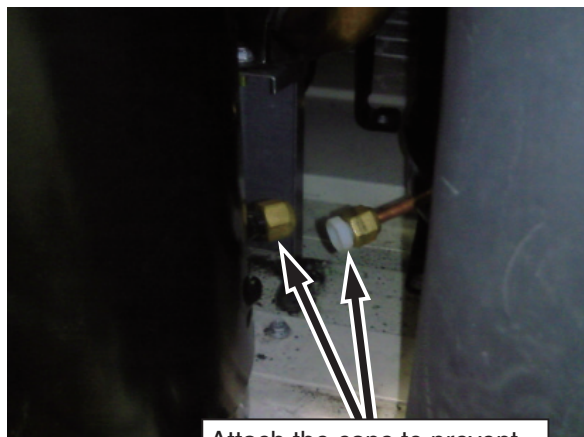

Attach the caps to prevent oil from flowing out after removing the flare nuts.

Oil may flow out. Attach the caps promptly after removing the flare nuts.



- (7) Remove the bolts(3 locations), washers, and spacers.
  - \* Use a crowbar to remove the cushioning rubbers just like inverter compressor removal procedure.



**CAUTION**

- **Protect the sensors and surrounding plates, rubber, lead wires, clamps, and other items.**  
**Pay particular attention to protection of the oil equalizer tube connector parts, and removal of the discharge sensor.**  
**An O-ring is mounted inside the oil equalizer tube connector parts. It must be protected and do not lose it.**

- (8) Remove the rubber band fixing the two tubes.

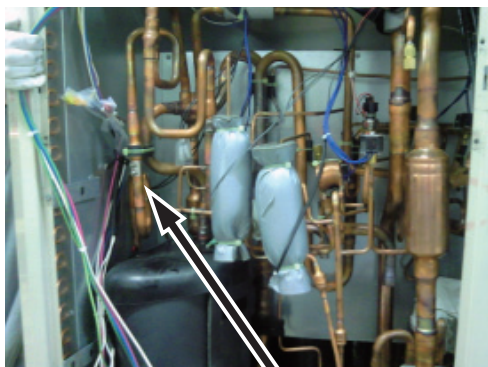

Cut the clamp and remove the rubber band.

- (9) Disconnect the discharge tubing.
  - \* Pull up the discharge tubing holding it with wet cloth.
- (10) Disconnect the suction tubing.
  - \* Protect the surrounding wiring, clamps, and rubber bands when brazing.

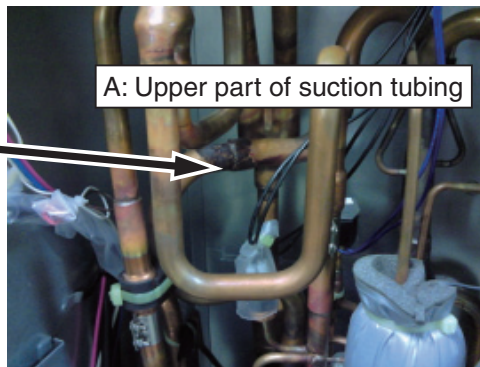
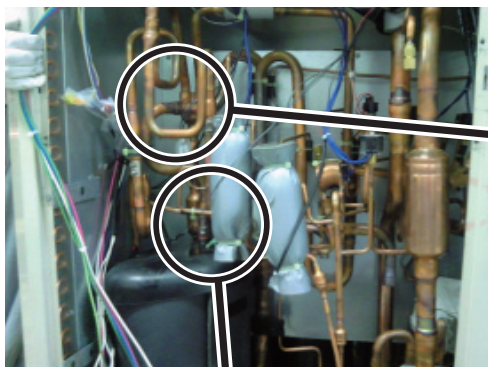

A: Upper part of suction tubing

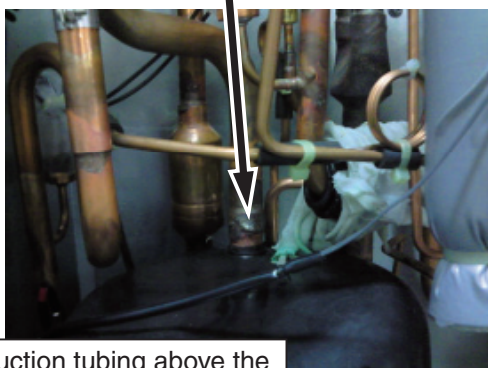

B: Suction tubing above the compressor

First, disconnect the upper part of the suction tubing (A) sideways. Then, disconnect the suction tubing above the compressor (B).  
The disconnected tube is used later. So, do not damage the tube.

- (11) Pull the compressor toward you.

## ■ Installation

- (1) Remove the rubber stopper and tube cap (brazed) from the new compressor.
- (2) Install the crankcase heater onto the new compressor.
- (3) Temporary mount 2 cushion rubbers with bolts at the position in front.  
Set up the leg of the the new compressor onto the 2 cushion rubbers.
- (4) Set the remaining cushioning rubber beneath the new compressor leg.
- (5) Anchor the 3 com-pressor legs using the bolts, washers, and rubber washers.

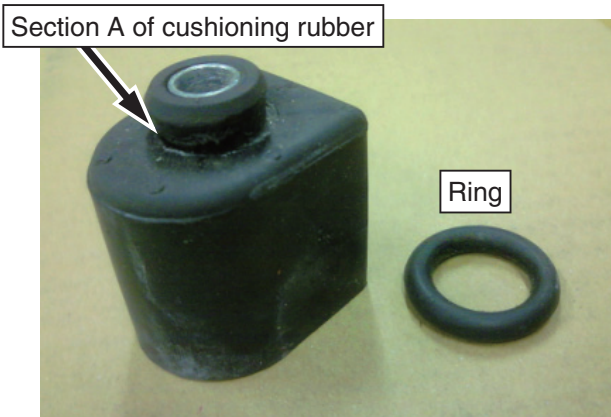

Insert A of the cushioning rubber securely to the leg of the compressor when attaching the bolt. Then attach the ring.  
\* If A is not inserted properly, it may damage the tubing.

- (6) Connect the manifold gauge to the high- and low-pressure outlet ports at the outdoor unit where the compressor was replaced. Connect the manifold gauge to a nitrogen cylinder and perform nitrogen gas replacement.
- (7) Remove the flare nut from the new compressor, and connect the tube-with-flare-nut.
- (8) Perform copper brazing at the 3 brazing locations.



**CAUTION**

**In the same way as during removal, pay particular attention to protection of the oil equalizing tube connector parts.**

**An O-ring is mounted inside the oil equalizer tube connector parts. It must be protected and do not lose it.**

- (9) Follow the instructions in “5. Checking for Leakage After Repair” and check for leaks at the outdoor unit where the compressor was replaced.
- (10) Reinstall the rubber band to fix the two tubes

Fix the suction and discharge tubing to the proper position with the rubber band.  
(Refer to the figure when the rubber band is removed.)

\* At shipment, a 8 mm-wide plastic clamp is used.

Use the stainless-steel clamp (CV9380208259) for reinstallation. After reinstalling, cut the excessive ends of the clamp so that they don't contact tubing and wirings.

- (11) Re-install the cap and acoustic material.



**CAUTION**

**Be sure to check for looseness of the power terminal connection at the compressor terminal plate, and to check by pulling vertically on the connections. If the terminals become disconnected easily, replace the wiring Assy.**

- (12) Follow the instructions in “6. Evacuating System” and apply vacuum to the outdoor unit where the compressor was replaced.

## (C) Replacing the constant-speed compressor 2 (For models U-18ME1E8(E), U-20ME1E8(E))

### ■ Removal

- (1) Connect the manifold gauge to the high- and low-pressure outlet ports at the outdoor unit where the compressor will be replaced. Connect the manifold gauge to a nitrogen cylinder and perform nitrogen gas replacement.
- (2) Remove the panels and the corresponding parts from the outdoor unit where the compressor will be replaced.
- (3) Remove the cap and acoustic material that surrounds the compressor.

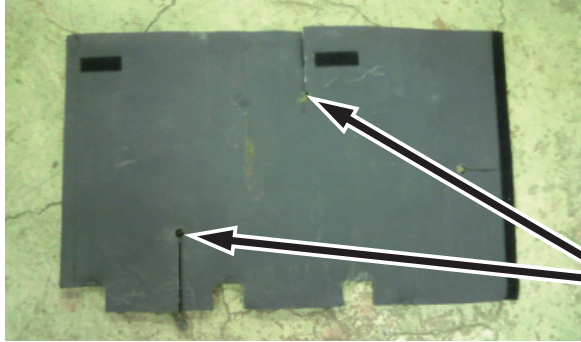

These areas are easily torn.  
Be careful not to damage.

- (4) Remove the cap at the compressor terminal plate. Disconnect the power cable.
- (5) Remove the crankcase heater.
- (6) Disconnect the tube-with-flare-nut using wrenches. At this time, cover the tube in place with waste cloth while watching out for oil leaks. Then cap the disconnected tube and mount the flare nut on the compressor. Tighten the flare nut with a seal bonnet(1/4") in it.

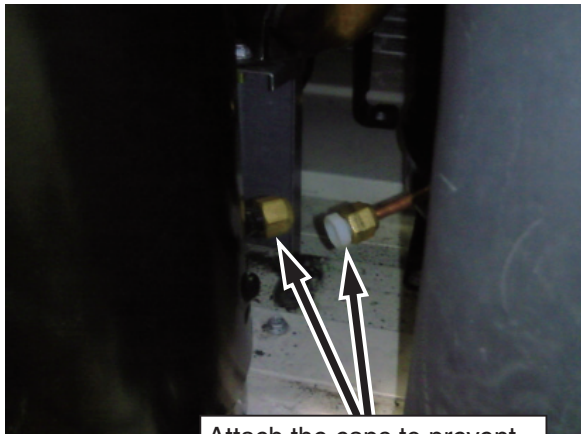

Attach the caps to prevent  
oil from flowing out after  
removing the flare nuts.

Oil may flow out. Attach the caps  
promptly after removing the flare nuts.

- (7) Remove the bolts(3 locations), washers, and spacers.  
\* Use a crowbar to remove the cushioning rubbers just like inverter compressor removal procedure.



CAUTION

- **Protect the sensors and surrounding plates, rubber, lead wires, clamps, and other items.**  
Pay particular attention to protection of the oil equalizer tube connector parts, and removal of the discharge sensor.  
An O-ring is mounted inside the oil equalizer tube connector parts. It must be protected and do not lose it.

- (8) Remove the rubber band fixing the two tubes.



Cut the clamp and remove the rubber band.

- (9) Disconnect the discharge tubing.  
\* Pull up the discharge tubing holding it with wet cloth.
- (10) Disconnect the suction tubing.



Cover the suction tubing where it comes down from the compressor with cloth and pull up when brazing filler metal melts.

Cover this position with cloth and pull up.

- (11) Pull the compressor toward you.



## ■ Installation

- (1) Remove the rubber stopper and tube cap (brazed) from the new compressor.
- (2) Install the crankcase heater onto the new compressor.
- (3) Temporary mount 2 cushion rubbers with bolts at the position in front.  
Set up the leg of the the new compressor onto the 2 cushion rubbers.
- (4) Set the remaining cushioning rubber beneath the new compressor leg.
- (5) Anchor the 3 com-pressor legs using the bolts, washers, and rubber washers.

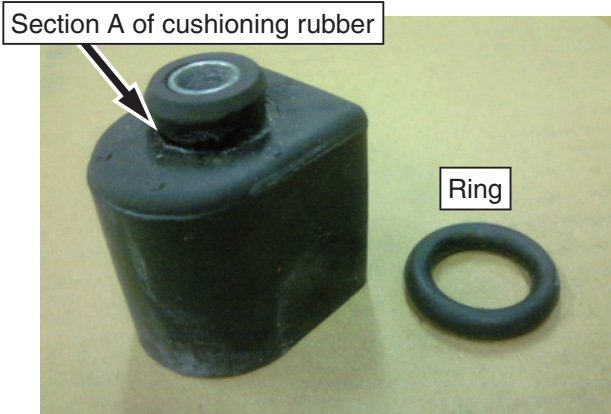

Insert A of the cushioning rubber securely to the leg of the compressor when attaching the bolt. Then attach the ring.  
\* If A is not inserted properly, it may damage the tubing.

3

- (6) Connect the manifold gauge to the high- and low-pressure outlet ports at the outdoor unit where the compressor was replaced. Connect the manifold gauge to a nitrogen cylinder and perform nitrogen gas replacement.
- (7) Remove the flare nut from the new compressor, and connect the tube-with-flare-nut.
- (8) Perform copper brazing at the 3 brazing locations.



**CAUTION**

**In the same way as during removal, pay particular attention to protection of the oil equalizing tube connector parts.**

**An O-ring is mounted inside the oil equalizer tube connector parts. It must be protected and do not lose it.**

- (9) Follow the instructions in “5. Checking for Leakage After Repair” and check for leaks at the outdoor unit where the compressor was replaced.
- (10) Reinstall the rubber band to fix the two tubes

Fix the suction and discharge tubing to the proper position with the rubber band.  
(Refer to the figure when the rubber band is removed.)

\* At shipment, a 8 mm-wide plastic clamp is used.

Use the stainless-steel clamp (CV9380208259) for reinstallation. After reinstalling, cut the excessive ends of the clamp so that they don't contact tubing and wirings.

- (11) Re-install the cap and acoustic material.



**CAUTION**

**Be sure to check for looseness of the power terminal connection at the compressor terminal plate, and to check by pulling vertically on the connections. If the terminals become disconnected easily, replace the wiring Assy.**

- (12) Follow the instructions in “6. Evacuating System” and apply vacuum to the outdoor unit where the compressor was replaced.

## 4. OUTDOOR UNIT MAINTENANCE REMOTE CONTROLLER

1. Overview .....	4-2
2. Functions .....	4-3
3. Ordinary Display Controls and Functions .....	4-4
4. Monitoring Operations .....	4-9
5. Outdoor Unit Alarm History Monitor .....	4-11
6. Mode Settings .....	4-12

# 1. Overview

## OUTDOOR UNIT MAINTENANCE REMOTE CONTROLLER (CZ-RTC2) for W-2WAY ECO-i

### ■ About the outdoor unit maintenance remote controller

The outdoor unit utilizes nonvolatile memory (EEPROM) on its PCB. This allows EEPROM data to replace the setting switches that were present on previous PCBs. The outdoor unit maintenance remote controller is used to set and change these EEPROM data.

In addition to setting and checking the outdoor unit EEPROM data, this remote controller can also be used to monitor the outdoor unit alarm history, monitor the various indoor and outdoor temperatures, and check the indoor unit connection status (number of units, operating mode, etc.).

#### NOTE

Outdoor unit maintenance remote controller does not function as an ordinary remote controller. It is therefore only used for test runs and during servicing.

### [Service Checker Section]



CZ-RTC2

### System diagram

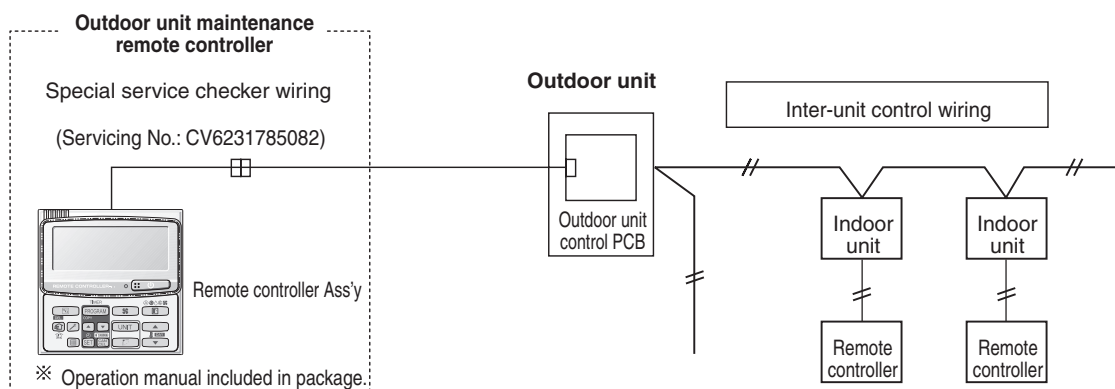

- The special service checker wiring is required in order to connect the outdoor unit maintenance remote controller to the outdoor unit PCB.
- Ordinary remote controllers or other controller are still required for the indoor units, even when the outdoor unit maintenance remote controller is connected.

## 2. Functions

### ■ Functions on the ordinary display

(1) Functions: Button operations can be used to perform the following functions.

- Start/stop of all indoor units
- Switching between cooling and heating
- Test run of all indoor units
- Double-speed operation of indoor units (Do not use for actual operation. Doing so may damage the devices.)

(2) Display: The following can be displayed.

- Alarm details display
- No. of indoor/outdoor units
- Unit Nos. of connected indoor/outdoor units
- Indoor/outdoor unit operating status (blinks when an alarm occurs)
- Indoor unit thermostat ON
- Display of individual outdoor unit alarms
- Total operating time of outdoor unit compressors
- Oil level of the outdoor unit oil sensor
- Total outdoor unit power ON time
- Outdoor unit microcomputer version, other information

### ■ Temperature monitor

- Displays the indoor/outdoor unit sensor temperatures.

### ■ Outdoor unit alarm history monitor

- Displays the outdoor unit alarm history.

### ■ Mode settings

- Setting mode 1 and setting mode 2 are used to make the outdoor EEPROM setting.

### ■ Functions on the ordinary display

- Connect the special service checker wiring to the outdoor unit PCB. The connection is shown in the figure below.

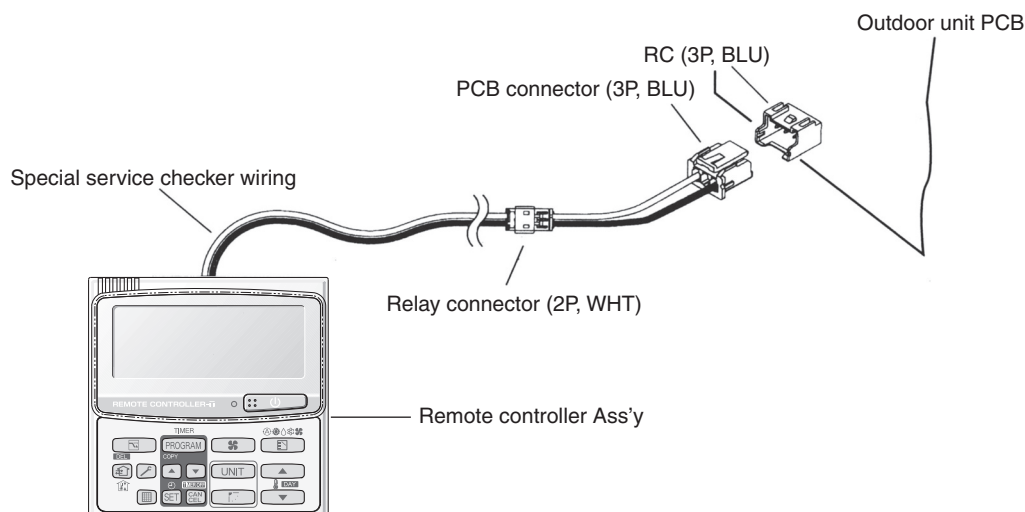

- If the communications line in the inter-unit control wiring is connected, it can be left as-is.
- In case of an independent outdoor unit (1 maintenance remote controller connected to 1 outdoor unit, automatic address setting for indoor units not completed), both setting mode 1 and setting mode 2 can be used.
- The overall system status for that refrigerant system is displayed.

### ● All units start/stop (Fig. 1)

<Operation>

The  (ON/OFF operation) button can be used to start and stop all the indoor units.

- The LED illuminates if any indoor units is operating.
- The LED blinks if an alarm at any of the operating indoor units occurs.

### ● Cooling/heating change (Fig. 1)

<Operation>

The  (MODE) button can be used to change between heating and cooling operation.

- The display indicates the operating mode of the indoor unit with the lowest unit No.

### ● All units test run (Fig. 2)

<Operation>

The  (CHECK) button can be used to start and stop a test run for all indoor units.

- Press and hold for 4 seconds to turn ON.  
During the test run "TEST" is displayed.
- The status of test runs performed from the indoor unit remote controller is not displayed on the outdoor unit maintenance remote controller.

### ● Double-speed

- Do not use for actual operation.  
(Doing so may damage the devices.)

<Operation>

The timer button  can be used to change between double-speed and normal operation.

- During double-speed operation, the SLEEPING MODE  mark is displayed.

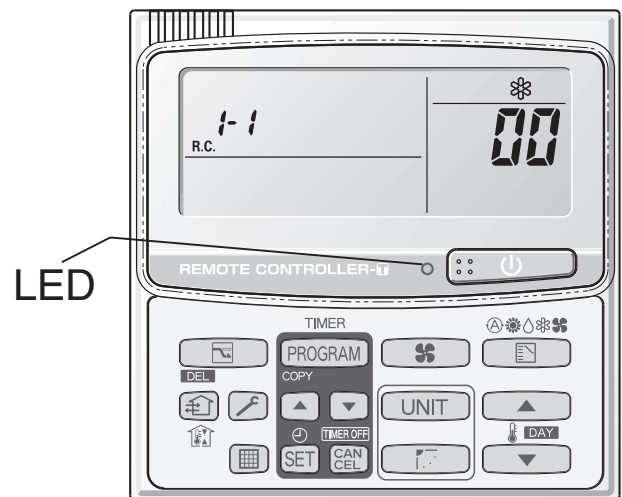

Fig. 1

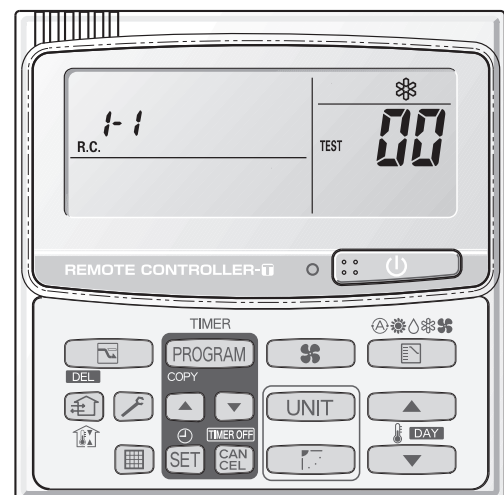
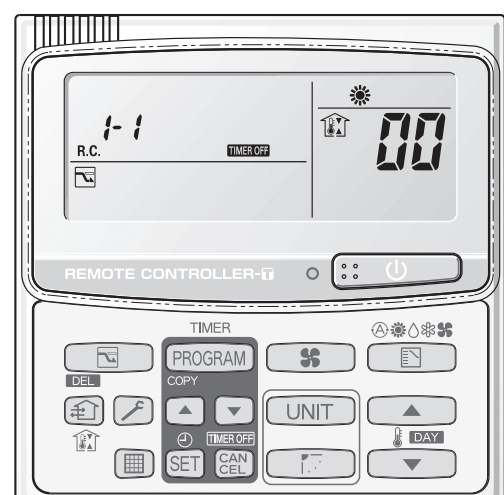

Fig. 2



### ■ Display (functions)

- Use the temperature setting  and  buttons to change the item code.

Item code	Item	Remarks
<b>00</b> ①	Outdoor unit alarm ②	Alarm code display
<b>01</b>	No. of connected indoor units	Quantity
<b>02</b>	Unit Nos. of connected indoor unit	7-segment display
<b>03</b>	Operating status of indoor unit	7-segment display
<b>04</b>	Thermostat ON status of indoor unit	7-segment display
<b>05</b>	No. of connected outdoor units	1 – 4
<b>06</b>	Unit Nos. of connected outdoor units	7-segment display
<b>07</b>	Operating status of outdoor unit compressor	7-segment display
<b>08</b>		
<b>09</b>		
<b>10</b>	Compressor 1 operating time	0 – 99999999 hrs
<b>11</b>	Compressor 2 operating time	0 – 99999999 hrs
<b>12</b>	Compressor 3 operating time	
<b>13</b>	Compressor 1 oil level	0 = Empty 1 = Insufficient 2 = Sufficient
<b>14</b>	Compressor 2 oil level	0 = Empty 1 = Insufficient 2 = Sufficient
<b>15</b>	Compressor 3 oil level	
<b>16</b>	Outdoor unit power ON time	0 – 99999999 hrs
<b>17</b>	Compressor 1 operation count	0 – 65535 times
<b>18</b>	Compressor 2 operation count	0 – 65535 times
<b>19</b>	Compressor 3 operation count	
<b>F0</b>	Alarm history 1 (most recent)	Display only. Alarm code and unit No. of unit where alarm occurred are displayed alternately. 0 = CCU 1 – 4 = Outdoor unit
<b>F1</b>	Alarm history 2	
<b>F2</b>	Alarm history 3	
<b>F3</b>	Alarm history 4	
<b>F4</b>	Alarm history 5	
<b>F5</b>	Alarm history 6	
<b>F6</b>	Alarm history 7	
<b>F7</b>	Alarm history 8 (oldest)	
<b>FE</b>	Firmware version	Display the version No. × 100.
<b>FF</b>	Program version	Display the version No. × 100.

### 3. Ordinary Display Controls and Functions

(3) XX-YY R.C.

Displays the outdoor unit sub-bus address which is currently selected.

XX = Outdoor system address on main bus line (1 – 30)

YY = Outdoor unit sub-bus address (1 – 8).

“1” appears when there is only 1 outdoor unit.

Locations where ①, ②, and ③ are displayed as shown in Fig. 3.

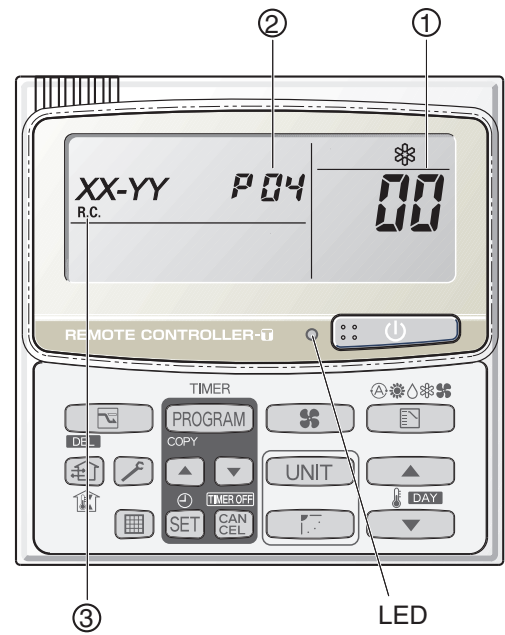

Fig. 3

<Sample displays>



01: <No. of connected indoor units>  
4 units connected

Fig. 4

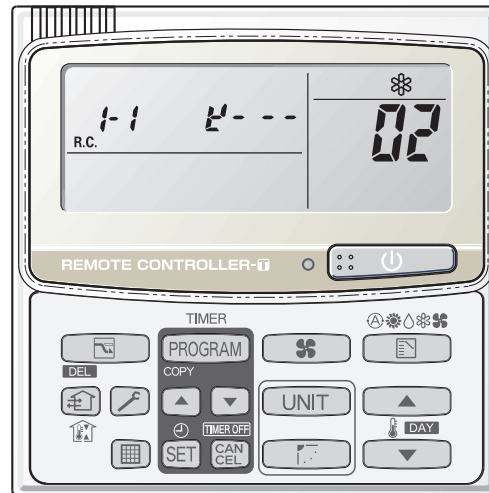

02: <Unit Nos. 1, 2, 3, and 4 are connected>

Fig. 5



■ Concerning the 7-segment, 4-digit display remote controller timer display

The unit Nos. of connected units are indicated by four 7-segment digits (00:00) and a colon.

● Display of unit Nos. 1 – 20

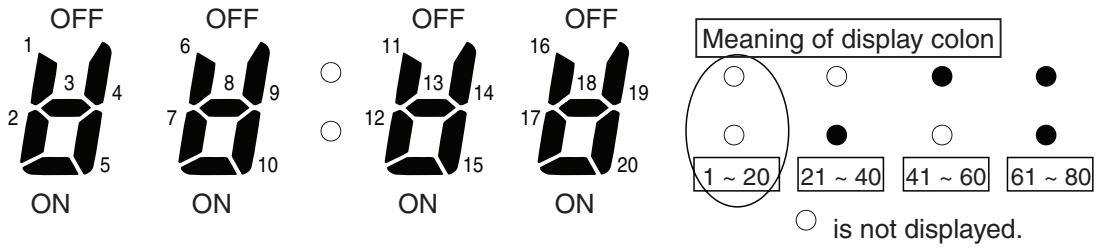

● Display of unit Nos. 21 – 40

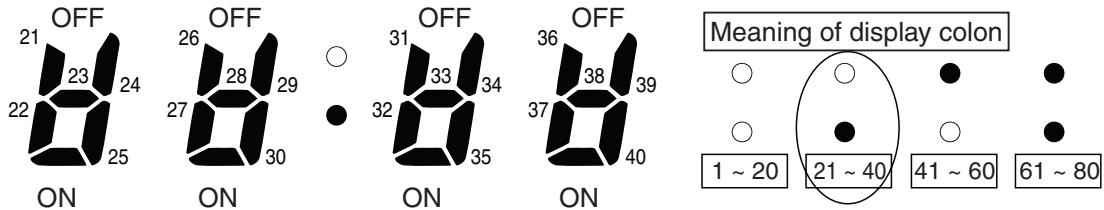

● The meaning of the colon changes in the same way to indicate unit Nos. up to 80.

● Sample displays of the connected indoor unit Nos.:

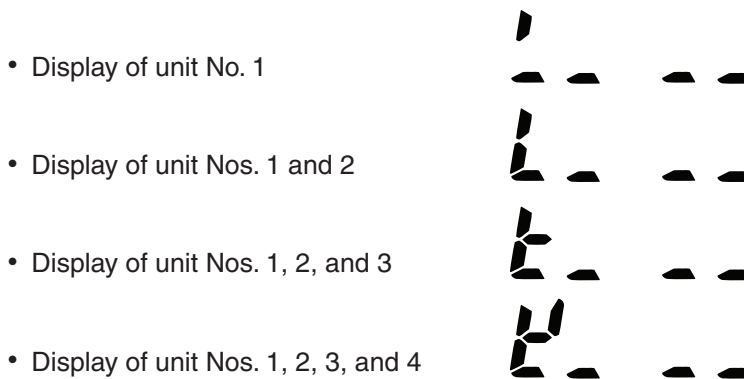

**NOTE**

The change of the colon display (between unit Nos. 1-20 to unit Nos. 21-40) occurs automatically every 10 seconds. (However the display does not change if there are no higher-number units connected.) To change the display to the higher-number units before 10 seconds have passed, press the (FLAP) button.

■ The total compressor operating time is displayed (in 1-hour units) using 8 digits.

- When the first 4 digits are displayed, the top dot of the colon is illuminated. (Figure (A))
- When the last 4 digits are displayed, the colon dot is OFF. (Figure (B))
- The display of the first 4 digits and last 4 digits changes automatically after 10 seconds. The display can also be changed by pressing the (FLAP) button.

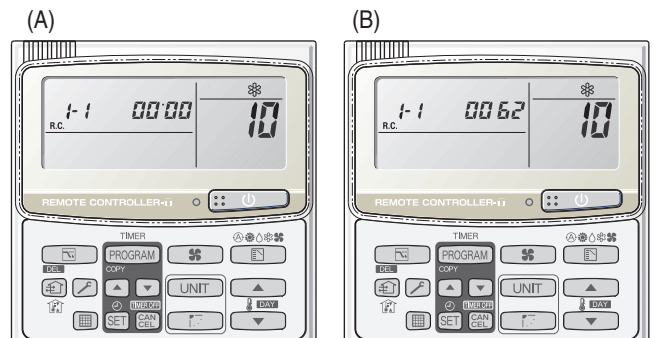

10: <Compressor's total operating time>  
(A) and (B) are displayed alternately.  
(The example here (0000, 0062) indicates 62 hours.)

**NOTE**

With the outdoor unit maintenance remote controller (when connected to the outdoor unit), the unit remote controller check functions will not operate.

## 4. Monitoring Operations



Display the indoor unit and outdoor unit sensor temperatures.

<Operating procedure>

- ① Press and hold the  (CHECK) button and  buttons simultaneously for 4 seconds or longer to engage temperature monitor mode.

During temperature monitoring,  is illuminates.

(The display and operations are the same as for monitor mode using the indoor unit remote controller.)

- ② Press the  button and select the indoor unit to monitor.
- ③ Press the temperature setting  and  buttons and select the item code of the temperature to monitor.

The unit No. of the selected indoor unit, and the temperature data, are displayed.

- ④ To end monitoring, press the  (CHECK) button. The display returns to the normal display.

**NOTE** The display does not blink.

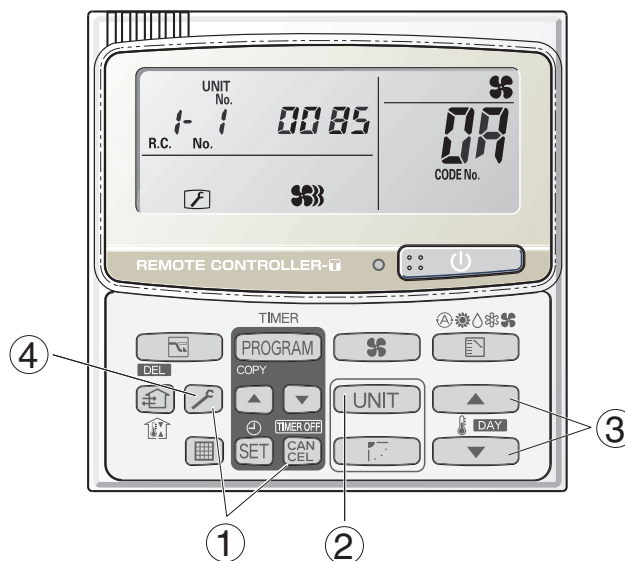

## 4. Monitoring Operations

### ■ Display of unit No. 1 (main unit)

DN	Description		Remarks
02	Intake temp.	°C	Indoor unit
03	E1	°C	
04	E2	°C	
05	E3	°C	
06	Discharge temp.	°C	
07	Discharge temp. setting	°C	
08	Indoor unit electronic control valve position	STEP	
0A	Discharge temp. 1	°C	
0B	Discharge temp. 2	°C	
0C	High-pressure sensor temp.	°C	
0d	Heat exchanger gas 1	°C	Outdoor unit
0E	Heat exchanger liquid 1	°C	
0F	Heat exchanger gas 2	°C	
10	Heat exchanger liquid 2	°C	
11	Outdoor air temp.	°C	
12	Not used		
13	Inverter primary current	A	
14	CT2	A	
15	MOV1 pulse	STEP	
16	MOV2 pulse	STEP	
17	Discharge temp. 3	°C	
18	CT3	A	
19	MOV3 pulse	STEP	
1A	MOV4 pulse	STEP	
1b	Heat exchanger gas 3	°C	
1C	Heat exchanger liquid 3	°C	
1d	Low-pressure sensor temp.	°C	
1E	Suction temp.	°C	
1F	Oil 1	°C	
20	Oil 2	°C	
21	Oil 3	°C	
22	Actual operating frequency	Hz	



#### NOTE

0A and subsequent items are outdoor unit data. 0A – 22 are for unit No. 1.  
2A – 42 are for unit No. 2. 4A – 62 are for unit No. 3. 62 – 89 are for unit No. 4.

## 5. Outdoor Unit Alarm History Monitor



- Displays outdoor unit alarms only.
- Check the indoor unit alarm histories separately using the indoor unit remote controllers or other control device.

### <Operating procedure>

- ① Press and hold the  (CHECK) button and  button simultaneously for 4 seconds or longer to engage outdoor unit alarm history mode.

During temperature monitoring,  illuminates.

The display and operations are the same as for the alarm history monitor performed from the indoor unit remote controller. However the “unit No.” display shows the outdoor unit address.

- ② Press the  button and select the outdoor unit for which to monitor the alarm history.
- ③ Press the temperature setting  and  buttons and select the item code for the alarm history.

The select outdoor unit address, the item code, and the alarm history (alarm data) are displayed.

The outdoor unit address is displayed as R.C. XX-YY.



System XX = Outdoor unit system address

R.C. XX = Outdoor unit system address

YY = Outdoor unit sub-bus address

Item codes 01-08 are displayed. 01 indicates the most recent alarm.

The alarm history displays the alarm code. (If no alarm are present, then -- -- is displayed.)



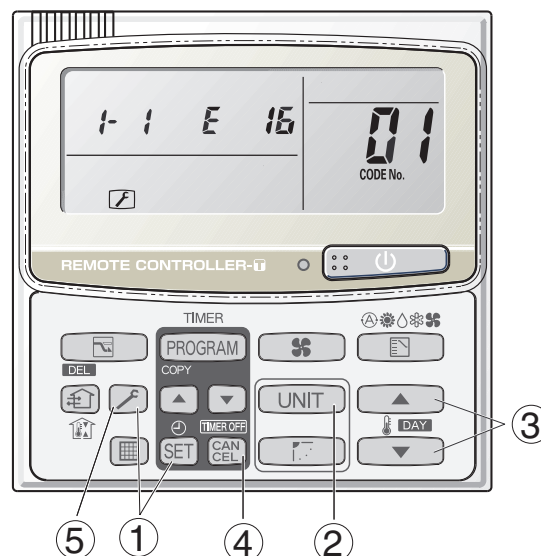



- ④ To clear the alarm history, press the  button. (The outdoor unit alarm history will be cleared.)
- ⑤ To exit, press the  (CHECK) button. The display returns to the normal display.



## 6. Mode Settings

### ■ Setting mode 1

<Operating procedure>

- ① Press and hold the  (CHECK) button and  (VENTILATION) button simultaneously for 4 seconds or longer.
- ② Press the temperature setting  and  buttons to change the item code. The item codes and setting data are shown in the table of “List of Item Codes” on the next page.
- ③ Press the timer time  and  buttons to change the setting data.

To confirm the changed setting data, press the  button.

(At this time, “SET DATA” display stops blinking and remains lit.)

- ④ During this mode, “SET DATA” is displayed, blinking. The outdoor unit address display section displays “ALL,” the item code and number (DN value in the table), and the setting data (8 digits).

(The setting data is displayed in 8 digits. The display changes between the first 4 digits (Fig. ①) and the last 4 digits (Fig. ②).

(When the first 4 digits are displayed, the top dot of the colon is illuminated.)

- ⑤ To exit the setting mode, press the  (CHECK) button.

① Display of first 4 digits

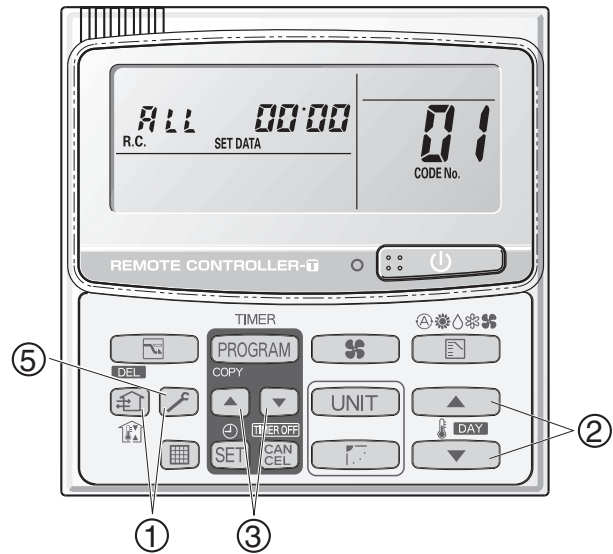

② Display of last 4 digits

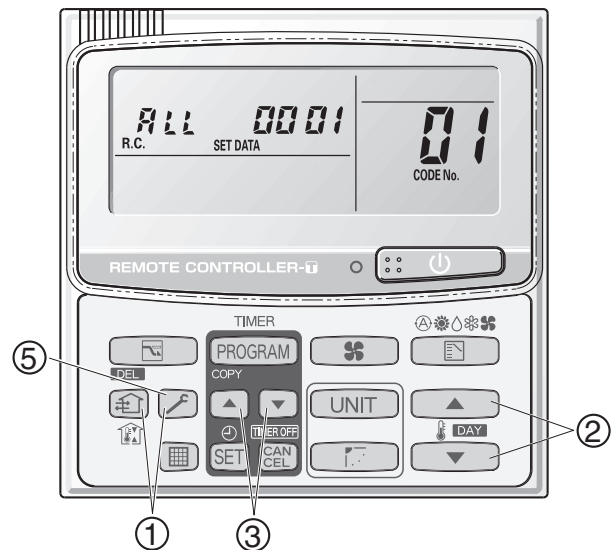









① and ② are displayed alternately.  
(Example shows display of 0000 0001.)

DN	Parameter	Description
04	Snowfall sensor usage	0 = Sensor input not present. Control is performed. 1 = Sensor input present. Control is performed. 2 = Sensor input not present. Control is not performed. 3 = Sensor input present. Control is not performed.
05	Outdoor unit fan Quiet mode	0 = Disabled                      1 = Quiet mode 1 2 = Quiet mode 2                3 = Quiet mode 3 4 = Quiet mode 4
18	Energy saving mode	0 = None 1 = Discharge temp. control only (Mode 3) 2 = Demand only (Mode 2) 3 = Discharge temp. control + Demand (Mode 1)
19	Energy saving operation plug	0 = Independent 1 = All indoor units linked
1A	Demand 1 current	0 = 0%   1 = 40 ... 4 = 70   7 = 100   8 = 120 9 = 140   10 = 160   11 = 200   12 = -1 (no limit)
1b	Demand 2 current	0 = 0%   1 = 40 ... 4 = 70   7 = 100   8 = 120 9 = 140   10 = 160   11 = 200   12 = -1 (no limit)

## 6. Mode Settings

### ■ Setting mode 2

<Operating procedure>

- ① Press and hold the  (CHECK) button,  button, and  button simultaneously for 4 seconds or longer.
- ② Press the temperature setting  and  buttons to change the item code. The item codes and setting data are shown in the table below.
- ③ Press the timer time  and  buttons to change the setting data. To confirm the changed setting data, press the  button.  
(At this time, "SET DATA" display stops blinking and remains lit.)

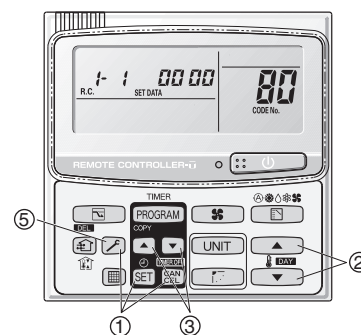
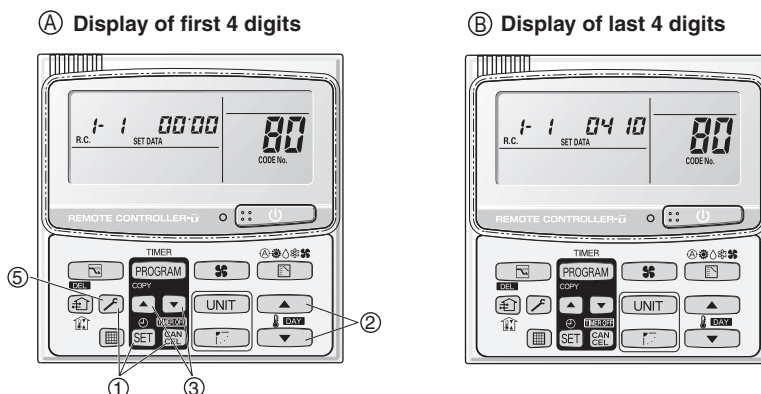

Fig. 7

- ④ During this mode, "SET DATA" is displayed, blinking. The display shows the set outdoor unit address "System XX-YY" (System XX = System address, YY = Address at outdoor unit sub-bus), item code number (DN value in the table below), and the setting data (8 digits).

(The setting data is displayed in 8 digits. The display changes between the first 4 digits (Fig. ㉔) and the last 4 digits (Fig. ㉕). When the first 4 digits are displayed, the top point of the colon is lit.)

- ⑤ To exit setting mode, press the  (CHECK) button. Returns to the normal display mode.



**80** : <Refrigerant type> ㉔ and ㉕ are displayed alternately. (Example shows 0000 0410 (R410A).)

### List of Item Codes

DN	Parameter	Description
81	Outdoor unit capacity	0 = Disabled, 224 = 8HP Type, 280 = 10HP Type, 355 = 12HP Type, 400 = 14HP Type, 450 = 16HP Type, 500 = 18HP Type, 560 = 20HP Type



## 5. REMOTE CONTROLLER FUNCTIONS

- 1. Simple Settings Function ..... 5-2
- 2. Detailed Settings Function ..... 5-4
- 3. Remote Controller Servicing Functions ..... 5-17





# 1. Simple Settings Function





- This allows the filter lifetime, operating mode priority change, central control address, and other settings to be made for an individual or group-control indoor unit to which the remote controller used for simple settings is connected.

When simple settings mode is engaged, operation stops at the individual or group-control indoor unit to which the remote controller for simple settings is connected.

## <Procedure>

- Press and hold the  and  buttons simultaneously for 4 seconds or longer.
- "SET DATA," unit No. "1 1" (or "ALL" in the case of group control), item code "01," and settings data "00XX" are displayed blinking on the remote controller LCD display (Fig. 1). At this time, the indoor unit fan (or all indoor unit fans in the case of group control) begins operating.
- If group control is in effect, press the **UNIT** button and select the address (unit No.) of the indoor unit to set. At this time, the fan at the indoor unit begins operating.

\* If unit No. "ALL" is displayed, the same setting will be made for all indoor units.

- Press the temperature setting  /  buttons to select the item code to change.
- Press the timer time  /  buttons to select the desired setting data.

\* For item codes and setting data, refer to the following page.

- Press the **SET** button. (The display stops blinking and remains lit, and setting is completed.)
- Press the  button to return to normal remote controller display.

## [Remote Controller Functions Section]

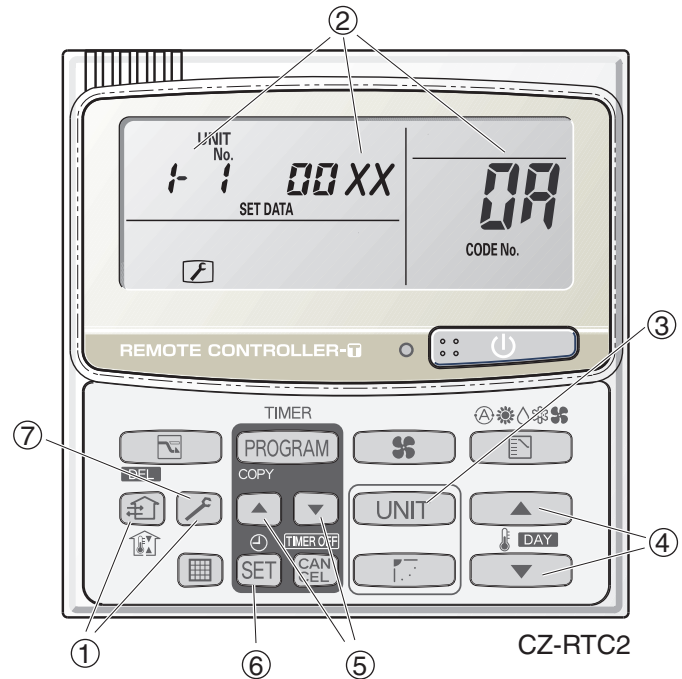

Fig. 1

## List of Simple Setting Items

Item code	Item	Setting data		
		No.	Description	
01	Filter sign ON time (filter life time)	0000	Not displayed	
		0001	150 hours	
		0002	2,500 hours	
		0003	5,000 hours	
		0004	10,000 hours	
		0005	Use the filter clogging sensor.	
02	Degree of filter fouling	0000	Standard (setting at time of shipping)	
		0001	Highly fouled (Filter sign ON time is reduced to one-half the set time.)	
03	Central control address	0001	Central control address 1	
		0002	Central control address 2	
		0003	Central control address 3	
		}	}	
		0064	Central control address 64	
		0099	No central control address set (setting at time of shipping)	
04	Operating mode priority change	0000	Normal (setting at time of shipping)	
		0001	Priority	
05	Fan speed when heating thermostat is OFF		Compressor ON	Compressor OFF
		0000	MED 1 min., LO 3 min.	LO
		0001	MED	LO
		0002	LO	LO
		0004	MED 1 min., LO 3 min.	MED
		0005	MED	MED
		0006	LO	MED
06	Heating intake temperature shift	0000	No shift	
		0001	Shifts intake temperature 1°C down.	
		0002	Shifts intake temperature 2°C down.	
		0003	Shifts intake temperature 3°C down.	
		0004	Shifts intake temperature 4°C down.	
		0005	Shifts intake temperature 5°C down.	
		0006	Shifts intake temperature 6°C down.	
07	Electric heater installation	0000	No heater	
		0001	Heater installed	
08	Humidifying when heater thermostat is OFF	0000	No (setting at time of shipping)	
		0001	Yes	
0d	Permit/prohibit automatic heating/cooling	0000	Permit	
		0001	Prohibit	
0F	Cool-only	0000	Normal	
		0001	Cool only (Set "1" for item code OD.)	

### NOTE

- In order to avoid water leakage and damage to the fan, do not set for humidifying when the thermostat is OFF unless a vaporizing humidifier is used.
- Consider the device purpose and type when changing the settings. Incorrect settings may result in malfunction.
- Do not change any setting data that does not appear in this list.
- The 10-hp 4-way ceiling cassette has 2 indoor unit addresses. Set both of them.





## 2. Detailed Settings Function

- This allows the system address, indoor unit address, and other settings to be made for the individual or group-control indoor unit to which the remote controller used for detailed settings is connected.

When detailed settings mode is engaged, operation stops at the individual or group-control indoor unit where the remote controller used for detailed settings is connected. Simple settings items can also be set at this time.

### <Procedure>

- Press and hold the , **SET** and **CAN CEL** buttons simultaneously for 4 seconds or longer.
- "SET DATA," unit No. "1 1" (or "ALL" in the case of group control), item code "10," and settings data "00XX" are displayed blinking on the remote controller LCD display (Fig. 2).  
At this time, the indoor unit fan (or all indoor unit fans in the case of group control) begins operating.
- If group control is in effect, press the **UNIT** button and select the address (unit No.) of the indoor unit to set. At this time, the fan at the indoor unit begins operating.

- Press the temperature setting  /  buttons to select the item code to change.
- Press the timer time  /  buttons to select the desired setting data.

\* For item codes and setting data, refer to the following page.

- Press the **SET** button. (The display stops blinking and remains lit, and setting is completed.)
- Press the  button to return to normal remote controller display.

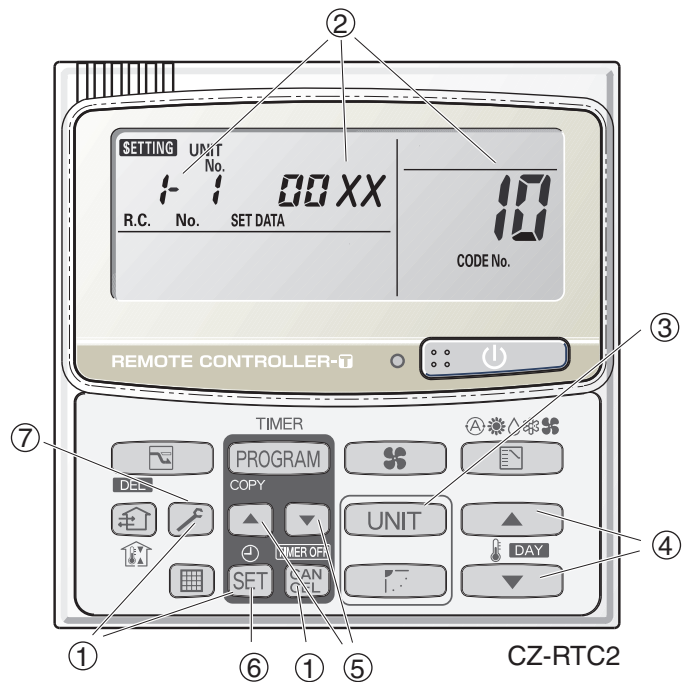
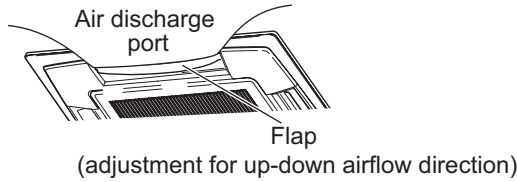

Fig. 2

## 2. Detailed Settings Function

- Setting the Flap Separately (When setting the CZ-RTC2)
  - The 4-air outlet flap can be adjusted separately during operation. When not adjusted separately, all flaps operate in the same manner.



<Procedure>

**Stop the system before performing these steps.**

- Press and hold the , **SET** and **CAN CEL** buttons simultaneously for 4 seconds or longer.
- If group control is in effect, press the **UNIT** button and select the address (unit No.) of the indoor unit to set. At this time, the fan at the indoor unit begins operating.
- "**SETTING**," unit No. "**- -**" (or "**ALL**" in the case of group control), item code "**XX**," and settings data "**YYYY**" are displayed blinking on the remote controller LCD display.
- Designate the item code "**XX**" by adjusting the Temperature Setting / buttons.

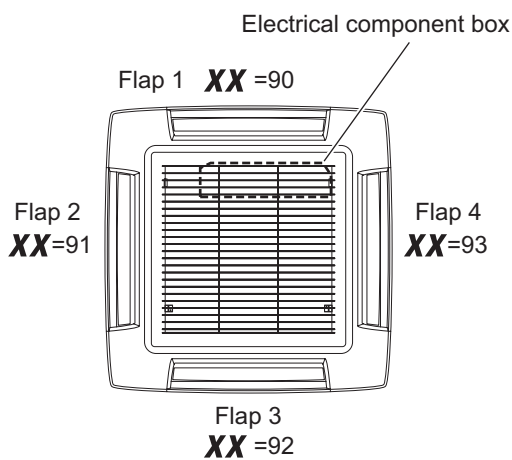

- Press the timer time / buttons to select the desired setting data.

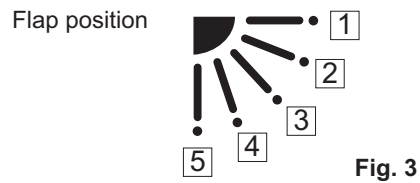

\* Setting data "**YYYY**" (refer to Fig.3)

Setting data	Flap position during operation
<b>0000</b>	Without separate setting
<b>0001</b>	Swing
<b>0002</b>	Move to position <b>1</b> and stay
<b>0003</b>	Move to position <b>2</b> and stay
<b>0004</b>	Move to position <b>3</b> and stay
<b>0005</b>	Move to position <b>4</b> and stay
<b>0006</b>	Move to position <b>5</b> and stay

When the flap position is set to **4** or **5** and the unit is in the cooling or dry mode, the flap position is moved to **3** and the operation is started. (refer to Fig.3)

### NOTE

The flap swings during the operation under "Setting the Flap Separately".

At this time, the unselected flaps are moved to the position **1**. (refer to Fig.3)

- Press the **SET** button.  
(The display stops blinking and remains lit, and setting is completed.)  
If you wish to change the selected indoor unit, follow the step ② .

- Press the button to return to normal remote controller display.

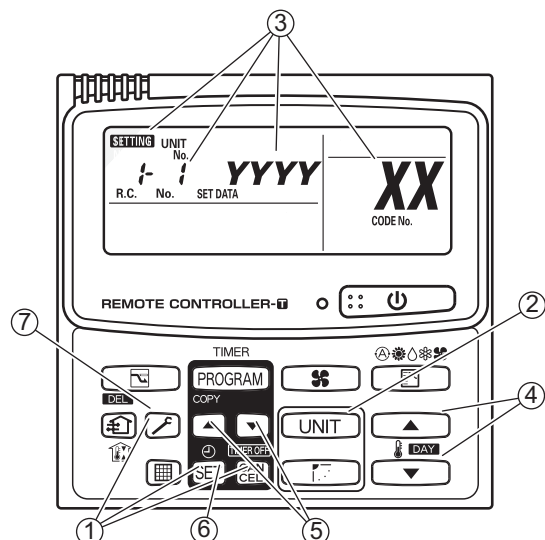

## List of Detailed Setting Items

Item code	Item	Setting data					
		No.	Description	No.	Description	No.	Description
10	Type	0001	4-Way Casstte (60×60) (U1, Y1)	0002	2-WAY Cassette (L1)	0003	1-Way Cassette (D1)
		0005	Low Silhouette Ducted (F1) Slim Low Static Ducted (M1)	0006	High Static Pressure Ducted (E1)	0007	Ceiling (T1)
		0008	Wall mounted (K1)	0010	Floor Standing (P1)	0011	Concealed Floor Standing (R1)
11	Indoor unit capacity	0001	22 (Type 22)	0003	28 (Type 28)	0005	36 (Type 36)
		0007	45 (Type 45)	0009	56 (Type 56)	0011	71 (Type 73) For S-71MP1E5 and S-71MR1E5
		0012	80 (Type 73) (Except S-71MP1E5, S-71MR1E5)	0013	90 (Type 90)	0015	112 (Type 106)
		0017	140 (Type 140)	0018	160 (Type 160)	0021	224 (Type 224)
		0023	280 (Type 280)				
12	System address	0001	Unit No. 1				
		0002	Unit No. 2				
		0003	Unit No. 3				
		}	}				
		0030	Unit No. 30				
		0099	Not set				
13	Indoor unit address	0001	Unit No. 1				
		0002	Unit No. 2				
		0003	Unit No. 3				
		}	}				
		0064	Unit No. 64				
		0099	Not set				
14	Group control address	0000	Individual (1:1 = Indoor unit with no group wiring)				
		0001	Main unit (One of the group-control indoor units)				
		0002	Sub unit (All group-control indoor units except for main unit)				
		0099	Not set				
17	Cooling intake temperature shift	-010	Shifts intake temperature by -10°C.				
		-009	Shifts intake temperature by -9°C.				
		}	}				
		-001	Shifts intake temperature by -1°C.				
		0000	No intake temperature shift				
		0001	Shifts intake temperature by +1°C.				
		}	}				
		0009	Shifts intake temperature by +9°C.				
0010	Shifts intake temperature by +10°C.						
18	Automatic stop time after operation start  *Can be set in 5-minute units.	0000	Function disabled				
		0001	Stops automatically 5 minutes after operation starts.				
		0002	Stops automatically 10 minutes after operation starts.				
		}	}				
		0123	Stops automatically 615 minutes after operation starts.				
		0124	Stops automatically 620 minutes after operation starts.				
		0125	Stops automatically 625 minutes after operation starts.				

## 2. Detailed Settings Function

Item code	Item	Setting data		
		No.	Description	
<b>1b</b> (1B)	Forced thermostat ON time	0000	5 minutes	
		0001	4 minutes	
<b>1c</b>	Cooling discharge temperature shift	-010	-10°C	
		-009	-9°C	
		-008	-8°C	
		}	}	
		0010	10°C	
<b>1d</b>	Heating discharge temperature shift	-010	-10°C	
		-009	-9°C	
		-008	-8°C	
		}	}	
		0010	10°C	
<b>1e</b>	Temperature shift for cooling/heating change in auto heat/cool mode	0001	±1°C	
		0002	±2°C	
		0003	±3°C	
		}	}	
		0007	±7°C	
<b>1f</b> (Upper limit) <b>20</b> (Lower limit)	Change to remote control temperature setting range	Cooling	0018	18°C (Lower limit at shipment)
			0019	19°C
			}	}
			0029	29°C
			0030	30°C (Upper limit at shipment)
			Heating	0016
		0017		17°C
		}		}
		0029		29°C
		0030		30°C (Upper limit at shipment)
		Drying		0018
			0019	19°C
}	}			
0029	29°C			
0030	30°C (Upper limit at shipment)			
Auto heat/cool	0017		17°C (Lower limit at shipment)	
	0018	18°C		
	}	}		
	0026	26°C		
	0027	27°C (Upper limit at shipment)		
	<b>29</b>	Humidifier operation	0000	Normal
0001			Ignore heat exchanger temperature conditions.	
<b>2a</b>	Filter (CN70) input switching	0000	Filter input (differential pressure switch input)	
		0001	Alarm input (for trouble input about air cleaner or similar device)	
		0002	Humidifier input (Operates linked with drain pump when humidifier is ON.)	
<b>2c</b>	Indoor unit electronic control valve	0000	Present (Setting at shipment)	
		0002	None	
<b>2e</b>	T10 terminal switching	0000	Normal (Used as optional relay PCB or JEMA standard HA terminal.)	
		0001	Used for OFF reminder	
		0002	Fire prevention input	

## 2. Detailed Settings Function

Item code	Item	Setting data	
		No.	Description
2F	Automatic drain pump operation	0000	No forced operation
		0001	Forced operation for 1 minute
		}	}
		0060	Continuous operation
31	Ventilation fan operation	0000	None
		0001	Ventilation fan operated by remote controller.
32	Wired remote controller sensor	0000	Not used. (Body sensor is used.)
		0001	Remote control sensor is used.
34	"Operation change control in progress" display	0000	Normal (displayed)
		0001	Not displayed
35	OFF reminder function for when weekly timer is used	0000	None
		0001	Only stop time setting is enabled.
3A	Discharge temperature control	0000	Discharge temperature control OFF
		0001	Discharge temperature control ON
3C	Heat exchanger temperature for cold air discharge (Heat exchanger control point for control to prevent cold air)	0013	Control temperature 13°C
		0014	Control temperature 14°C
		}	}
		0025	Control temperature 25°C
		0026	Control temperature 26°C
3d	Fan output switching	0000	Output linked with fan. (ON when indoor unit fan is operating.)
		0001	Fan mode operation output
3E	Drain pump delayed start time	0000	No delayed start
		0001	1 sec. delayed start
		0002	2 sec. delayed start
		}	}
		0058	58 sec. delayed start
		0059	59 sec. delayed start
		0060	60 sec. delayed start
40	Humidifier setting	0000	Humidifier output OFF. Drain pump stopped.
		0001	Humidifier output ON. Drain pump operates.
		0002	Humidifier output ON. Drain pump operates for 1 minute when total humidifier operating time reaches 60 minutes.
		0003	Humidifier output ON. Drain pump stopped.
45	Flap operation mode	0000	Standard setting
		0001	Draft reduction mode (Flap lower-limit position is shifted upwards.)
46	Flap swing mode	0000	Smudging reduction mode (Flap swing upper-limit position is shifted downwards.)
		0001	Normal mode
		0002	Draft reduction mode (Flap swing lower-limit position is upwards.)

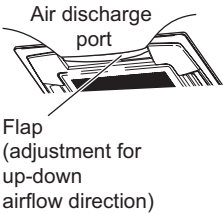
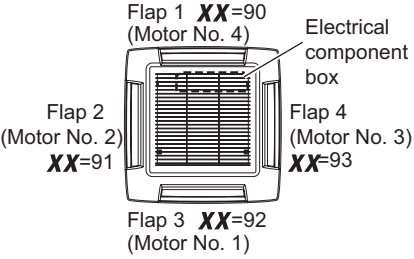
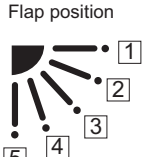

Item code	Item	Setting data				
		No.	Description			
5d	Fan tap setting (Fan tap change in order to prevent drop in air discharge caused by filter installation)		DC fan tap operating mode	Purpose		
		0000	Standard	Standard (setting at shipment)		
		0001	High ceiling use	High ceiling setting 1 (with standard panel)		
			For low static-pressure filter	Ultra long-life filter, oil guard panel, ammonia deodorizing filter, optical regenerative deodorizing filter		
		0003	High ceiling use	High ceiling setting 2 (with standard panel)		
			For low static-pressure filter	(Antibacterial) high-performance filter (90%) (Antibacterial) high-performance filter (65%)		
Air-cleaning unit, air-cleaning unit + optical regenerative deodorizing filter, deodorant (activated charcoal) filter						
	For air-blocking material	For 3-way discharge, when discharge duct is connected				
0006	For air-blocking material	For 2-way discharge				
5E	Humidifier ON time (ON time per 60 seconds)	0000	No humidifier output			
		0001	1 sec.			
		0002	2 sec.			
		}	}			
		0058	58 sec.			
		0059	59 sec.			
		0060	Continuously ON			
5F	Repeat timer switching	0000	Function disabled			
		0001	Function enabled			
60	Timer function change prohibit	0000	Function disabled			
		0001	Function enabled			
62	Smudging control	0000	No smudging control			
90	Setting the Flap Separately *Only for 4-way Cassette type	0000	 <p>Air discharge port</p> <p>Flap (adjustment for up-down airflow direction)</p>	 <p>Flap 1 <b>XX</b>=90 (Motor No. 4)</p> <p>Flap 2 (Motor No. 2) <b>XX</b>=91</p> <p>Flap 3 <b>XX</b>=92 (Motor No. 1)</p> <p>Flap 4 (Motor No. 3) <b>XX</b>=93</p> <p>Electrical component box</p>	 <p>Flap position</p>	
		0001				
		0002				
91	Setting the Flap Separately *Only for 4-way Cassette type	0003				
		0004				
92	Setting the Flap Separately *Only for 4-way Cassette type	0005				
		0006				
93	Setting the Flap Separately *Only for 4-way Cassette type		Setting data	Flap position during operation		
			0000	Without separate setting		
			0001	Swing		
			0002	Move to position 1 and stay		
			0003	Move to position 2 and stay		
			0004	Move to position 3 and stay		
			0005	Move to position 4 and stay		
	0006	Move to position 5 and stay				

When the flap position is set to 4 or 5 and the unit is in the cooling or dry mode, the flap position is moved to 3 and the operation is started.

**NOTE**

The flap swings during the operation under "Setting the Flap Separately". At this time, the unselected flaps are moved to the position 1.



## Simple setting items

Item code	Item	Description
01	Filter sign ON time setting (filter lifetime)	Changes the indoor unit filter lifetime when a high-performance filter or other optional product is installed.
02	Degree of filter fouling	Reduces the filter sign ON time to 1/2 of the standard time (setting at the time of shipping) for cases when filter fouling is more severe than normal.

## Filter sign ON times for each model

Model data	Model	Filter sign ON time										Pressure differential switch
		Standard		Long-life		Super long-life		High performance 65		High performance 90		
		Standard	High fouling	Standard	High fouling	Standard	High fouling	Standard	High fouling	Standard	High fouling	
0001	4-Way cassette (U1, Y1)	×	×	2500	1250	5000	2500	2500	1250	×	×	×
0002	2-Way cassette (L1)	×	×	2500	1250	10000	5000	2500	1250	2500	1250	×
0003	1-Way cassette (D1)	×	×	2500	1250	×	×	×	×	×	×	×
0005	Low Silhouette Ducted (F1) Slim Low Static Ducted (M1)	×	×	×	1250	5000	2500	2500	1250	5000	2500	×
0006	High Static Pressure Ducted (E1)	×	×	×	1250	×	×	2500	1250	5000	2500	×
0007	Ceiling (T1)	×	×	2500	1250	×	×	2500	1250	×	×	×
0008	Wall Mounted (K1)	150	75	×	×	×	×	×	×	×	×	×
0010	Floor Standing (P1)	150	75	×	×	×	×	×	×	×	×	×
0011	Concealed Floor Standing (R1)	150	75	×	×	×	×	×	×	×	×	×

Unit: hour

### NOTE

- × indicates that there is no corresponding filter.
- 150 indicates the filter sign ON time that is set at shipment.
- High fouling: Set when 002 is selected for the degree of filter fouling (item code 02).

Item code	Item	Description
03	Central control address	Set when using a central control device. Used when setting the central control address manually from the remote controller.
04	Operating mode priority change	Note (1)

### NOTE

#### (1) Explanation of operation mode priority change

Enabled only in 2WAY System heat-pump models.

#### <Function>

With indoor units that are installed in combination with an outdoor unit model where either heating or cooling operation can be selected, the operating mode of the indoor unit that starts first takes priority. The first indoor unit to operate can select any operating mode. When any mode other than fan mode is selected, then the operating modes that cannot be selected are not displayed on all remote controllers that are subsequently operated. "Operation change control in progress" is displayed, indicating that there are restrictions on the operating modes that can be selected.

#### • Controlling the operating mode from a specific remote controller

- When there are multiple remote controllers in the same refrigerant system, it is possible to set one remote controller as the priority remote controller (the remote controller which is given priority for selecting the operating mode). (If 2 or more remote controllers are set as priority remote controllers, an alarm will occur at the remote controllers, and operation will not be possible.)
- When the priority remote controller is set to the operating mode for control, then all other remote controllers can select only the permitted operating mode, regardless of whether the priority remote controller is operating or stopped.
- When a controlled remote controller is operated, "Operation change control in progress" is displayed.

Set mode at priority remote controller	Modes that can be selected at other remote controllers
Cooling or dry	Cooling, dry, fan
Heating	Heating, fan
Fan	Whichever mode (heating/cooling) is selected first

### NOTE

There are other methods to avoid control in which the mode selected first takes priority.

Methods of remotely controlling the operating mode

- (1) Use the central functions of a central control device.
- (2) Use a remote control relay PCB at the outdoor unit.

When the operating mode at the priority remote controller is changed, the operating modes of other remote controllers change as shown below.

Mode change at priority remote controller		Operating modes at other remote controllers	
Current mode	New mode	Current mode	New mode
Cooling or dry	Heating	Cooling or dry	Heating
		Fan	Fan (not changed)
Heating	Cooling	Heating	Cooling
		Fan	Fan (not changed)
Cooling	Dry	Cooling	Cooling (not changed)
		Dry	Dry (not changed)
Heating	Dry	Heating	Cooling
		Fan	Fan (not changed)
Cooling or dry	Fan	Cooling	Cooling (not changed)
		Dry	Dry (not changed)
		Fan	Fan (not changed)
Heating	Fan	Heating	Heating (not changed)
		Fan	Fan (not changed)

Item code	Item	Description
05	Fan speed setting when heating thermostat is OFF	Changes the fan speed setting when the heating thermostat is OFF.
06	Heating intake temperature shift	Shifts the intake temperature during heating. Can be set when the body thermostat is used.
07	Electric heater installation	Set when cost distribution is performed using an AMY central control system or similar system, and when an optional electric heater is installed. (This is unrelated to control of the electric heater.)
08	Humidifying when heater thermostat is OFF	Normally humidifying does not occur when the thermostat is OFF during heating operation. However, this setting can be changed in order to increase the amount of humidifying. Caution: In order to avoid water leakage and damage to the fan, do not use this setting unless a vaporizing humidifier is used.
0D	Permit/prohibit automatic heating/cooling	This setting can be used to prevent the automatic heating/cooling display on the remote control if the unit configuration permits automatic heating/cooling operation.
0F	Cooling-only	This setting allows a heat pump indoor unit to be operated as a cooling-only unit.

Item code	Item	Description
10	Unit type	Set when the indoor unit EEPROM memory is replaced during servicing.
11	Indoor unit capacity	
12	System (outdoor unit) address	These are not set at the time of shipping from the factory. These must be set after installation if automatic address setting is not performed.
13	Indoor unit address	
14	Group address	
17	Cooling intake temperature shift	Shifts the intake temperature during cooling and dry operation. (Enabled only when the body thermostat is used.) Increase this value when it is difficult to turn the thermostat ON.
18	Automatic stop time after operation start	The time at which an indoor unit is automatically stopped after operation starts can be set in increments of 5 minutes.
1E	Temperature shift for cooling/heating change in "auto heat/cool" mode	"Auto heat/cool" selects the operating mode automatically based on the difference between the room temperature and the temperature set on the remote controller. This setting establishes a shift temperature for the heating/cooling temperature setting relative to the remote controller temperature setting.

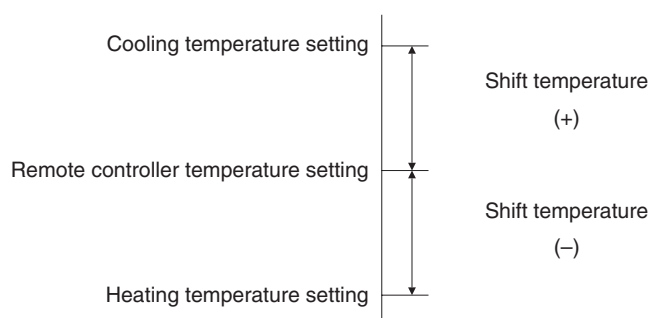

Item code	Item	Description	
1F (Upper limit) 20 (Lower limit)	Change to the remote control temperature setting range	This setting changes the temperature range (upper limit and lower limit) which is set from the remote controller or central control device. The set upper limit must be greater than or equal to the lower limit. If the temperature setting is to be a single point, set the upper limit and lower limit to the same temperature.	
21 (Upper limit) 22 (Lower limit)			Cooling
23 (Upper limit) 24 (Lower limit)			Heating
25 (Upper limit) 26 (Lower limit)			Drying
29	Humidifier operation which ignores the heat exchanger temperature	Auto heat/cool	
29	Humidifier operation which ignores the heat exchanger temperature	During heating operation, the humidifier operates when the heat exchanger temperature is suitable for humidifying. This setting is used to ignore this condition for humidifier operation and operate the humidifier more.	
2A	Filter input switching	This setting switches the filter input according to the purpose of use.	
2C	Indoor unit electronic control valve	This setting indicates whether or not an indoor unit electronic control valve is present. At the time of shipping, this setting is set according to the conditions of the indoor unit.	
2E	T10 terminal input switching	Ordinarily, the T10 terminal is used as the HA terminal at the time of shipping. However, this setting is used when the T10 terminal is used for OFF reminder or for fire prevention input.	
31	Ventilation fan operation from remote controller	It is possible to install a total heat exchanger and ventilation fan in the system, which can be started and stopped by the wired remote controller. The ventilation fan can operate linked with the start and stop of the indoor unit, or can be operated even when the indoor unit is stopped. Use a ventilation fan that can accept the no-voltage A contact as the external input signal. In the case of group control, the fans are operated together. They cannot be operated individually.	
32	Switching to remote controller sensor	This setting is used to switch from the body sensor to the remote controller sensor. Check that "remote controller sensor" is displayed. Do not use this setting with models that do not include a remote controller sensor. Do not use this setting if both the body sensor and remote sensor are used.	
34	ON/OFF of "Operation change control in progress" display	In a MULTI system with multiple remote controllers, switching between heating and cooling is restricted, and "Operation change control in progress" is displayed. This setting is used to prevent this display from appearing. Refer to the item concerned with operating mode priorities.	
35	OFF reminder function for weekly timer	This setting switches the operation when the weekly timer is connected to the remote controller. This can be used to prevent cases in which the unit is accidentally left ON. There is no change when this setting is ON, however it is necessary to set the weekly timer ON time.	

(Continued)

(Continued from previous page)

Item code	Item	Description
3C	Heat exchanger temperature for cold air discharge	The heat exchanger temperature control point for prevention of cold air discharge during heating operation can be changed.
3d	Fan output switching	The indoor unit PCB optional output for the fan can be switched according to the purpose of use.
3E	Drain pump delayed start time	The drain pump starts after the set time delay after cooling operation stops.
40	Humidifier drain pump setting	This specifies the humidifier and drain pump setting.
45	DC flap operation mode	Changes flap operation to draft reduction mode.
46	DC flap swing mode	Selects the swing operation mode for the flap.
5d	DC fan tap setting	Sets the DC fan tap according to the purpose of use. Change the settings data at the same time.
5E	Humidifier ON time	Sets the humidifier output ON time for when the humidifier is operating. ON/OFF control is performed during humidifier operation. This setting therefore sets the ON time per 60-second interval.
5F	Stop at time set for OFF timer after operation starts	This setting enables a function that stops operation when the amount of time set for the OFF timer has passed after remote controller operation was started.
60	Timer function change prohibit	This function prohibits changes from being made to the remote controller time setting.
62	Smudging control	Smudging control is disabled when 0000 is set.

## Selecting the DC fan motor tap (when setting from the PCB)

### ● 4-Way Cassette type

<Procedure> Stop the system before performing these steps.

- ① Open the electrical component box cover, then check the indoor unit control PCB.
- ② Connect the jumper connector (2P: yellow) which was supplied with the accessory to the correct connector pin on the indoor unit control PCB according to the setting number which was confirmed in Table for DC Fan Motor Tap Settings.

Setting No. (3) :

Then connect the jumper connector to the connector pin TP3 (2P: yellow) on the indoor unit control PCB.

Setting No. (6) :

Then connect the jumper connector to the connector pin TP6 (2P: white) on the indoor unit control PCB.

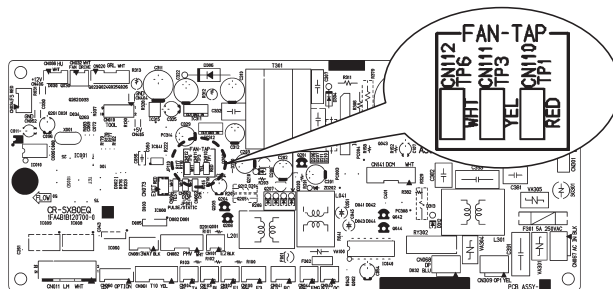

Fig. 4

### ● Ceiling type

<Procedure> Stop the system before performing these steps.

- ① Open the electrical component box cover, then check the indoor unit control PCB. (Fig. 5)
- ② Connect the jumper connector (2P: yellow) which was supplied with the accessory to the correct connector pin on the indoor unit control PCB according to the setting number which was confirmed in Table 2 (Table of DC Fan Motor Tap Settings).
  - If the setting No. is (1), then connect the jumper connector to the connector pin TP1 (2P: red) on the indoor unit control PCB.
  - If the setting No. is (3), then connect the jumper connector to the connector pin TP3 (2P: yellow) on the indoor unit control PCB.

### ● 1-Way Cassette type

<Procedure> Be sure to turn OFF the main power source before performing the steps below.

- ① Open the electrical component box cover, then check the indoor unit control PCB. (Fig. 5)
- ② Connect the jumper connector (2P: yellow) which was supplied with the accessory to the correct connector pin on the indoor unit control PCB according to the setting number which was confirmed in Table 3 (Table of DC Fan Motor Tap Settings).
  - When using with the high ceiling settings  
Connect the jumper connector to the connector pin TP1 (2P: red) on the indoor unit control PCB.
  - When using with the discharge grille (purchased separately) attached (2-way lowered ceiling system)  
Connect the jumper connector to the connector pin TP3 (2P: yellow) on the indoor unit control PCB.

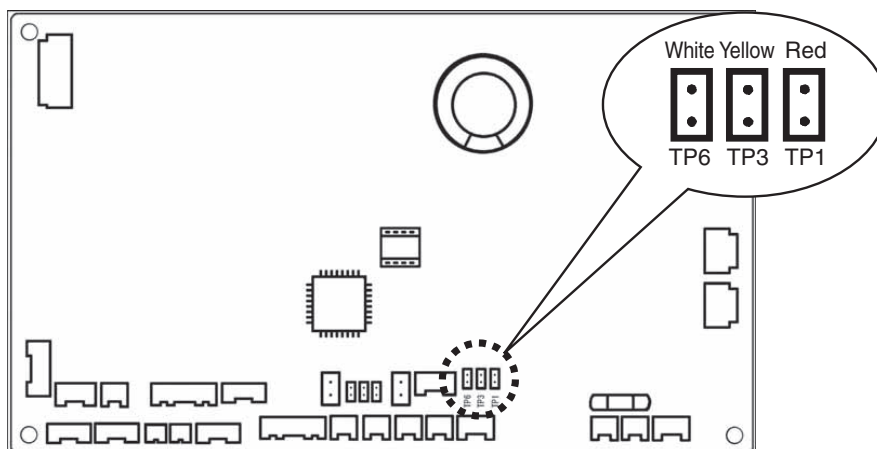

















Fig. 5

- The remote controller includes a number of servicing functions. Use these as needed for test runs and inspections.

#### List of Servicing Functions



Functions	Description	Button operation	Reset operation	Unit status
Test run	Operation with forced thermostat ON	Press and hold the  button for 4 seconds or longer.	Press the  button.	Current operation is maintained.
Sensor temperature display	Temperature display from each sensor	Press and hold the  and  buttons for 4 seconds or longer.		
Servicing check display	Alarm history display	Press and hold the  and  buttons for 4 seconds or longer.		
Simple settings	Filter life time, operating mode priority, central control address, and other settings	Press and hold the  and  buttons for 4 seconds or longer.		When settings are made from a remote controller, the indoor unit where that remote controller is connected stops.
Detailed settings	System address, indoor unit address, central control address, and other settings	Press and hold the  ,  and  buttons for 4 seconds or longer.		
Automatic address	Automatic address setting based on command from the wired remote controller	Press and hold the  and the timer operation  buttons for 4 seconds or longer.	Automatic reset	Entire system stops.
Address change	Change of indoor unit address	Press and hold the  and the timer operation  buttons for 4 seconds or longer.	Press the  button.	



#### Test Run Function

Operates the unit with the thermostat forced ON.

#### <Procedure>

- ① Press and hold the  button for 4 seconds or longer.
- ② “Test” appears on the remote controller LCD display (Fig. 6).
- ③ Start operation.
- ④ Press the  button to return to normal remote controller display.

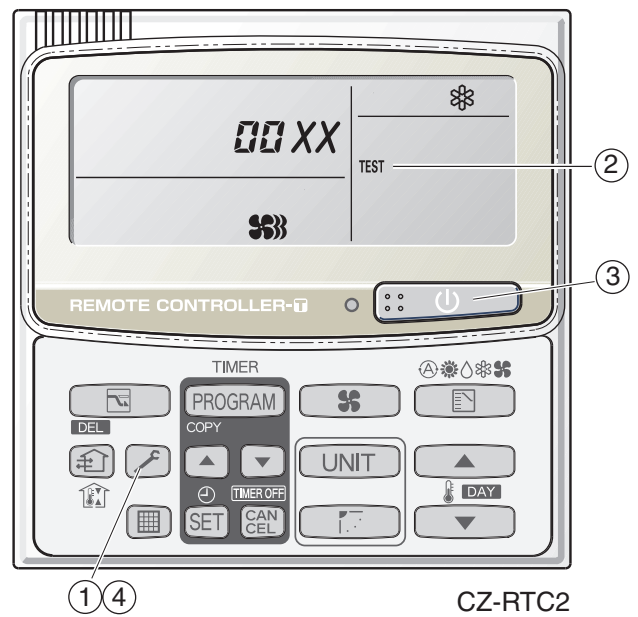







Fig. 6

## ■ Sensor Temperature Display Function (displayed regardless of whether unit is operating or stopped)

The procedure below displays the sensor temperatures from the remote controller, indoor unit, and outdoor unit on the remote controller.

### <Procedure>

- ① Press and hold the  and  buttons simultaneously for 4 seconds or longer.
- ② The unit No. "X-X" (main unit No.), item code "XX" (sensor address), and servicing monitor "00XX" (sensor temperature) are displayed on the remote controller LCD display. (See Fig. 7 at right.)
- ③ Press the temperature setting  /  buttons and select the item code to the address of the sensor to monitor.  
(For the relationships between the sensor addresses and sensor types, refer to the table of temperature sensors and addresses on the next page.)
- ④ If group control is in effect, press the  button to select the unit to monitor.  
Press the temperature setting buttons to select the item code to change.
- ⑤ Press the  button to return to normal remote controller display.

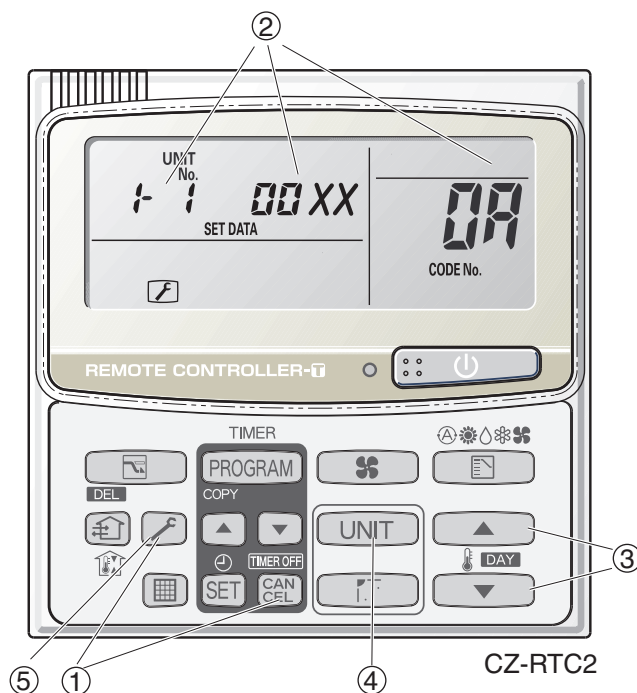

\* Display shows a discharge temperature of 85°C at unit No. 1-1.

Fig. 7

### NOTE

The temperature display appears as "- - -" for units that are not connected.

\* If monitor mode is engaged while normal operation is in progress, only the parts of the LCD display shown in the figure will change. Other parts continue to display the same information as during normal operation.

### 3. Remote Controller Servicing Functions

Indoor unit sensors		Outdoor unit sensors			
		Unit No.1	Unit No.2	Unit No.3	
02	Intake temp.	0A	2A	4A	Discharge temp. 1
03	E1	0B	2B	4B	Discharge temp. 2
04	E2	0C	2C	4C	High-pressure sensor temp.
05	E3	0D	2D	4D	Heat exchanger gas 1
06	Discharge temp.	0E	2E	4E	Heat exchanger liquid 1
07	Discharge temp. setting	0F	2F	4F	Heat exchanger liquid 2
08	Position of indoor unit electronic control valve	10	30	50	Heat exchanger liquid 2
		11	31	51	Outdoor air temp.
		12	32	52	—
		13	33	53	For inspection
		14	34	54	CT2
		15	35	55	For inspection
		16	36	56	For inspection
		17	37	57	Discharge temp. 3
		18	38	58	CT3
		19	39	59	For inspection
		1A	3A	5A	For inspection
		1B	3B	5B	Heat exchanger gas 3
		1C	3C	5C	Heat exchanger liquid 3
		1D	3D	5D	Low-pressure sensor temp.
		1E	3E	5E	Suction temp.
		1F	3F	5F	Oil 1
		20	40	60	Oil 2
		21	41	61	Oil 3
		22	42	62	For inspection

## 6. TROUBLE DIAGNOSIS

1. Contents of Remote Controller Switch Alarm Display .....	6-2
2. Outdoor Unit Control Panel LED Display .....	6-4
3. Remote Controller Servicing Functions .....	6-5
4. 2WAY Alarm Codes .....	6-7
5. Blinking Inspection Display on the Remote Controller .....	6-28
6. Inspection of Parts .....	6-30
7. Test Pin .....	6-31

# 1. Contents of Remote Controller Switch Alarm Display

ON: ○ Blinking: ☀ OFF: ●

Possible cause of malfunction			Wired remote control display	Wireless remote controller receiver display		
				Operation	Timer	Standby for heating
Serial communication errors Mis-setting	Remote controller is detecting error signal from indoor unit.	Error in receiving serial communication signal. (Signal from main indoor unit in case of group control) Outdoor system address, indoor unit address, or indoor unit address independent/main/sub unit setting has not been made. (Auto address is not completed.)	<E01>	Operating lamp blinking ☀ ● ●		
		Error in transmitting serial communication signal.	<E02>			
	Indoor unit is detecting error signal from remote controller and system controller.	<<E03>>				
	Indoor unit is detecting error signal from outdoor unit.	<ul style="list-style-type: none"> <li>Error in receiving serial communication signal.</li> <li>When turning on the power supply, the number of connected indoor units does not correspond to the number set. (Except R.C. address is "0.")</li> <li>Group wiring failure of indoor units in the refrigerant system (occurring when remote controller is operated immediately after automatic address setting)</li> </ul>	E04	Heating ready lamp blinking ● ● ☀		
	Outdoor unit is detecting error signal from indoor unit.	<ul style="list-style-type: none"> <li>Error in receiving serial communication signal.</li> <li>There is an indoor unit which does not send signals when the power is ON.</li> </ul>	E06			
	Improper setting	<ul style="list-style-type: none"> <li>Indoor unit address setting is duplicated.</li> <li>Duplicated remote controller "main" setting.</li> </ul>	<< E08>>	Operating lamp blinking ☀ ● ●		
			<< E09>>			
	Improper setting	Automatic address setting start is prohibited. AP pin was short-circuited at time when automatic address setting was started.	E12			
	Indoor unit communication error of group control wiring.	Error of main indoor unit in receiving serial communication signal from sub indoor units.	E18			
	During auto. address setting, number of connected units does not correspond to number set.	Number of connected indoor units is less than the number set.	E15	Heating ready lamp blinking ● ● ☀		
		Number of connected indoor units is more than the number set.	E16			
		No indoor unit is connected during auto. address setting.	E20			
		Main outdoor unit is detecting error signal from sub outdoor unit.	E24			
		Duplicated outdoor unit address.	E25			
		Mismatch in "No. of outdoor units" setting.	E26			
		Error of sub outdoor unit in receiving serial communication signal from main outdoor unit.	E29			
		Outdoor unit serial communications failure.	E30			
	Communication error between the microcomputers	E31				
	Improper setting	Connected indoor unit is not a multi unit.	<< L02>>	Operating and heating ready lamps blinking simultaneously ☀ ● ☀		
		Duplication of main indoor unit address setting in group control.	<L03>			
Duplicated indoor unit priority (priority indoor unit).		L05				
Duplicated indoor unit priority (non-priority indoor unit) and outdoor unit.		L06				
Indoor unit address is not set.		L08				
Capacity code of indoor unit is not set.		<< L09>>				
Mismatch of outdoor unit type.		L17				
4-way valve operation failure		L18				
Duplication of outdoor R.C. address setting.		L04				
Capacity code of outdoor unit is not set.		L10				
Group control wiring is connected to individual control indoor unit.	L07	☀ ○ ☀				
Thermistor fault	Indoor unit	Indoor coil temp. sensor (E1)	<< F01>>	Operating and timer lamps blinking alternately ☀ ☀ ●		
		Indoor coil temp. sensor (E3)	<< F03>>			
		Indoor suction air (room) temp. sensor	<< F10>>			
		Indoor discharge air temp. sensor	<< F11>>			

Continued

# 1. Contents of Remote Controller Switch Alarm Display

ON: ○ Blinking: ☀ OFF: ●

Possible cause of malfunction			Wired remote control display	Wireless remote controller receiver display		
				Operation	Timer	Standby for heating
Thermistor fault	Outdoor unit	Compressor 1 (INV) discharge temp. sensor	F04	Operating and timer lamps blinking alternately	☀	☀
		Compressor 2 (constant speed) discharge temp. sensor	F05			
		Compressor 3 (constant speed) discharge temp. sensor	F22			
		Outdoor air temp. sensor	F08			
		Heat exchanger 1 liquid temp. sensor	F07			
		Heat exchanger 1 gas temp. sensor	F06			
		Compressor intake temp. sensor (suction temp)	F12			
		High-pressure sensor	F16			
		Low-pressure sensor	F17			
		Heat exchanger 2 liquid temp. sensor	F24			
		Heat exchanger 2 gas temp. sensor	F23			
		Ceiling panel connection failure				
Protective device	Indoor unit	Thermal protector in indoor unit fan motor is activated.	<<P01>>	☀		
		Float switch is activated.	<<P10>>	●		
		Fan inverter protection function activated.	<<P12>>	☀		
	Outdoor unit	Oxygen (O <sub>2</sub> ) gas sensor activated.	P14	☀		
		Compressor thermal protector is activated. Power supply voltage is unusual. (More than 260V or less than 160V between L1 and L2 phase.)	P02	☀		
		Compressor 1 (INV) discharge temp. trouble	P03	☀		
		High-pressure switch	P04	☀		
		Reverse phase (missing phase) detected.	P05	☀		
		DCCT, ACCT overcurrent	P16	☀		
		Compressor 2 (constant speed) discharge temp. trouble	P17	☀		
		Compressor 3 (constant speed) discharge temp. trouble	P18	☀		
		High load alarm	P20	☀		
		Outdoor unit fan trouble	P22	☀		
INV compressor start failure. (Missing phase or lock alarm)	P29	☀				
Failure of nonvolatile memory IC (EEPROM) on indoor unit control PCB			F29	☀		
Failure of nonvolatile memory IC (EEPROM) on outdoor unit control PCB			F31	☀		
Protective device	Overload current detected.	Compressor 2 (constant speed)	H11	☀		
		Compressor 3 (constant speed)	H21	☀		
	Lock current detected.	Compressor 2 (constant speed)	H12	☀		
		Compressor 3 (constant speed)	H22	☀		
	No current detected when compressor was ON.	Compressor 1 (INV)	H03	☀		
		Compressor 2 (constant speed)	H13	☀		
		Compressor 3 (constant speed)	H23	☀		
	Discharge temp. sensor trouble	Compressor 1 (INV)	H05	☀		
		Compressor 2 (constant speed)	H15	☀		
	Outdoor unit protection	Low-pressure trouble	H06	☀		
HIC trouble alarm		H31	☀			
Low oil alarm			H07	☀		
Connection failure of oil detection sensor	Compressor 1 (INV)		H08	☀		
	Compressor 2 (constant speed)		H27	☀		
	Compressor 3 (constant speed)		H28	☀		
Fusing of electromagnetic contact (Current detected when compressor was OFF)			CHECK only blinking	(No display changes)		
Automatic backup operation						

<< >> alarm indication: Does not affect the operation of other indoor units.

< > alarm indication: In some cases may affect the operation of other indoor units.

## 2. Outdoor Unit Control Panel LED Display

( ○ : ON    ☼ : Blinking    ● : OFF)







LED (RED)		Display meaning
1	2	
○	○	After the power is turned ON (and automatic address setting is not in progress), no communication with the indoor units in that system is possible.
(Both ON)		
● (OFF)	○ (ON)	After power is turned ON (and automatic address setting is not in progress), one or more indoor units are confirmed in that system; however, the number of indoor units does not match the number that was set.
(Both OFF)		
☼	☼	Automatic address setting is in progress.
(Blinking alternately)		
☼	☼	At time of automatic address setting, the number of indoor units did not match the number that was set.
(Both blinking)		
☼	☼	Alarm display LED 1 blinks M times, then LED 2 blinks N times. The cycle then repeats. M = 2: P alarm 3: H alarm 4: E alarm 5: F alarm 6: L alarm N = Alarm No. Example: LED 1 blinks 2 times, then LED 2 blinks 17 times. The cycle then repeats. Alarm is "P17."
(Blinking alternately)		

### 3. Remote Controller Servicing Functions

#### Sensor temperature display function (displayed both when unit is running and stopped)

• Use the following check procedure to display the sensor temperatures from the remote controller, indoor unit, and outdoor unit sensors on the remote controller display.

#### <Check procedure>

- ① Press and hold the  (CHECK) button and  button simultaneously for 4 seconds or longer.
- ② The following appears on the remote controller LCD display: unit No. X – X (main unit No.), item code XX (sensor address), and service monitor 00XX (sensor temperature).  
(See figure at right. ②)
- ③ Press the temperature setting  and  buttons to change the item code to the sensor address of the sensor you wish to monitor.  
(For the relationship between the sensor address and sensor type, refer to the sensor temperature relationship table on next page.)
- ④ If group control is in effect, press the  button to change to the unit you wish to monitor.
- ⑤ Press the  (CHECK) button to return to normal remote controller operation.

<Note> The temperature display for units that are not connected appears as “- - - .”

- If monitor mode is engaged during ordinary operation, the only parts of the LCD display that change are those shown in ② in the figure. The other parts remain unchanged during normal operation.

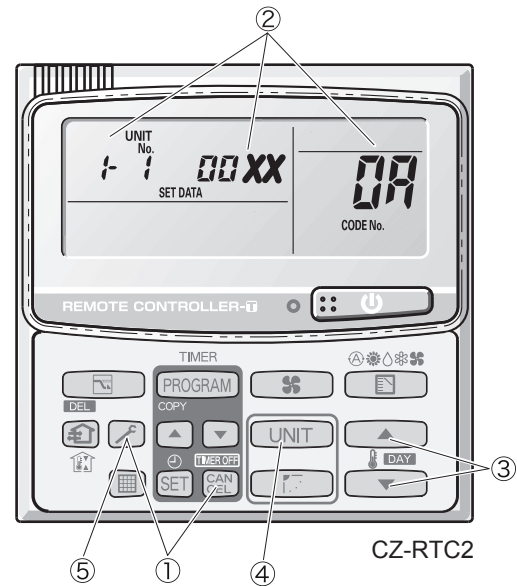

#### Example

1-1 : Unit No.  
0A : Item code (sensor address)  
00XX : Discharge temp. (TD)



### 3. Remote Controller Servicing Functions

**Sensor Temperature Relationship Table**

Location where sensor is installed	Sensor address			Sensor type	Sensor address			Sensor type
Indoor unit	01			Remote controller temperature	06			Discharge temperature sensor
	02			Indoor unit intake temperature	07			
	03			Indoor unit heat exchanger temperature (E1)	08			Indoor unit electronic expansion valve position
	04				09			
	05			Indoor unit heat exchanger temperature (E3)				
Outdoor unit	Unit No. 1	Unit No. 2	Unit No. 3		Unit No. 1	Unit No. 2	Unit No. 3	
	0A	2A	4A	Discharge temperature 1	17	37	57	Discharge temperature 3
	0b	2b	4b	Discharge temperature 2	18	38	58	CT3
	0C	2C	4C	High-pressure sensor temperature	1b	3b	5b	Heat exchanger gas 3
	0d	2d	4d	Heat exchanger gas 1	1c	3c	5c	Heat exchanger liquid 3
	0E	2E	4E	Heat exchanger liquid 1	1d	3d	5d	Low-pressure sensor temperature
	0F	2F	4F	Heat exchanger gas 2	1E	3E	5E	Detected reservoir tank temp.
	10	30	50	Heat exchanger liquid 2	1F	3F	6F	Detected oil temp. 1
	11	31	51	Outside air temperature	21	41	61	Detected oil temp. 2
	14	34	54	CT2	22	42	62	Detected oil temp. 3

## 4. 2WAY Alarm Codes

With type 8HP, the INV compressor is compressor 1 only.

With types 10HP, 12HP, 14HP and 16HP, the INV compressor is compressor 1, and the constant-speed compressors (AC1) are compressors 2 .

With types 18HP and 20HP, the INV compressor is compressor 1, and the constant-speed compressors (AC1, AC2) are compressors 2 and 3.

Alarm code	Alarm meaning	Page
E06	Outdoor unit failed to receive serial communication signals from indoor unit.	6-9
E12	Automatic address setting start is prohibited.	6-9
E15	Automatic address setting alarm (too few units)	6-9
E16	Automatic address setting alarm (too many units)	6-10
E20	No indoor units at automatic address setting.	6-10
E24	Outdoor unit (INV) failed to receive communications from another outdoor unit (constant-speed).	6-10
E25	Outdoor unit address setting failure (duplication)	6-11
E26	Mismatch in outdoor unit quantity	6-11
E29	Outdoor unit failed to receive communication from outdoor unit (main)	6-11
E31	Communication error between the microcomputers	6-11

F04	Compressor 1 discharge temperature sensor trouble	6-12
F05	Compressor 2 discharge temperature sensor trouble	6-12
F22	Compressor 3 discharge temperature sensor trouble	6-12
F06	Gas temperature sensor trouble at outdoor heat exchanger 1 (In)	6-13
F07	Liquid temperature sensor trouble at outdoor heat exchanger 1 (Out)	6-13
F08	Outdoor air temperature sensor trouble	6-14
F12	Compressor intake temperature sensor trouble	6-14
F16	High-pressure sensor trouble	6-15
F17	Low-pressure sensor trouble	6-16
F23	Gas temperature sensor trouble at outdoor heat exchanger 2 (In)	6-13
F24	Liquid temperature sensor trouble at outdoor heat exchanger 2 (Out)	6-13
F31	Outdoor unit non-volatile memory (EEPROM) trouble	6-16

H11	Constant speed compressor 2 overcurrent alarm	6-17
H12	Constant speed compressor 2 lock current alarm	6-17
H03	Compressor 1 CT sensor disconnected or short-circuit	6-18
H05	Compressor 1 discharge temperature sensor disconnected	6-18
H06	Low-pressure switch activated	6-19
H08	Compressor 1 oil detection sensor (connection) trouble	6-20
H13	Compressor 2 CT sensor disconnected or short-circuit	6-18
H15	Compressor 2 discharge temperature sensor disconnected	6-18
H21	Compressor 3 overcurrent alarm	6-17
H22	Compressor 3 lock current alarm	6-17
H23	Compressor 3 CT sensor disconnected or short-circuit	6-18
H25	Compressor 3 discharge temperature sensor disconnected	6-18
H27	Compressor 2 oil detection sensor (connection) trouble	6-20
H28	Compressor 3 oil detection sensor (connection) trouble	6-20
H31	HIC trouble alarm	6-21

L04	Outdoor system address duplication	6-21
L10	Outdoor unit capacity not set	6-22
L17	Outdoor unit model mismatch	6-22
L18	4-way valve operation failure	6-22

P02	Compressor thermal protector is activated.(trip only and no alarm)	6-22
P03	Compressor 1 discharge temperature trouble	6-23
P04	High-pressure switch activated	6-24
P05	Reverse phase (or missing phase) detected	6-24
P14	O2 sensor differential alarm (Only when optional O2 sensor supplied)	6-25
P16	Compressor 1 (INV) overcurrent alarm	6-25
P17	Compressor 2 discharge temperature trouble	6-23
P18	Compressor 3 discharge temperature trouble	6-23
P20	High load alarm	6-26
P22	Fan motor trouble	6-26
P29	Inverter compressor missing phase or lock alarm	6-27

Blinking Inspection Display on the remote controller	CHECK blinking (1)	6-28
	CHECK blinking (2)	6-29

## 4. 2WAY Alarm Codes

### E06 Alarm

<b>Alarm code</b>	<b>E06</b>
Alarm meaning	Outdoor unit failed to receive serial communication signals from indoor unit.
Alarm conditions	Outdoor unit failed to receive serial communication signals from indoor unit.
Probable cause	(1) The indoor unit power was cut OFF after initial communications were completed. (2) An open circuit or short-circuit occurred in the inter-unit control wiring after initial communications were completed.
Check	Check the power at the indoor and outdoor units, and check the inter-unit control wiring.
Correction	—
Example	—
Notes	This alarm is detected after initial communications are completed. Therefore, it does not occur in cases of “disconnected serial connector,” “no terminal unit set,” or other trouble that occurs before initial communications are completed. If initial communications have not been completed, alarm E04 occurs.

### E12 Alarm

<b>Alarm code</b>	<b>E12</b>
Alarm meaning	Automatic address setting start is prohibited.
Alarm conditions	Automatic address setting was started when automatic address setting was in progress at another outdoor unit in the same link.
Probable cause	Automatic address setting is in progress at another outdoor unit.
Check	This alarm is not displayed on the remote controller. Therefore check the blinking on the outdoor unit PCB.
Correction	Wait for automatic address setting to be completed at the outdoor unit where it is currently in progress. Then start automatic address setting again.
Example	—
Notes	—

### E15 Alarm

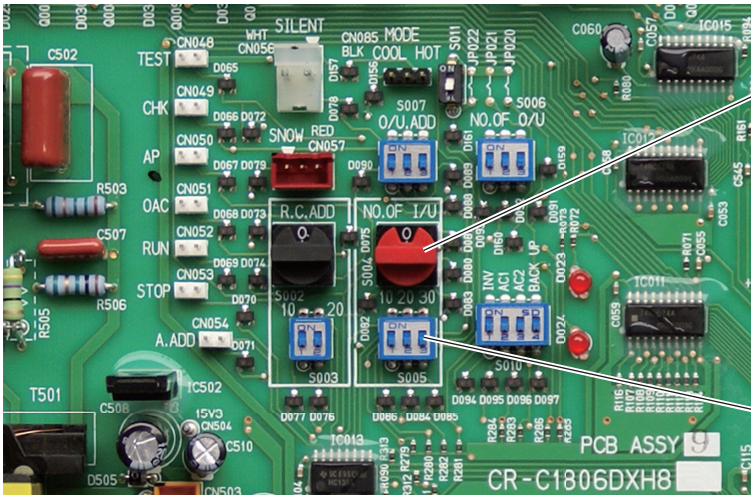
<b>Alarm code</b>	<b>E15</b>
Alarm meaning	Automatic address setting alarm (too few units)
Alarm conditions	The number of indoor units was too few when automatic address setting was performed.
Probable cause	(1) The number of indoor units set at the indoor unit quantity setting SW (S004, S005) on the outdoor unit PCB is too many. (2) The inter-unit control wiring between indoor units has been cut.
Check	(1) Refer to the test run servicing materials and check the indoor unit quantity setting SW (S004, S005). (2) Check the inter-unit control wiring at the indoor and outdoor units.
Correction	After correcting the indoor unit quantity setting or the inter-unit control wiring, perform automatic address setting again.
Example	—
Notes	2WAY switch position 

## 4. 2WAY Alarm Codes

### E16 Alarm

Alarm code	E16
Alarm meaning	Automatic address setting alarm (too many units)
Alarm conditions	<ul style="list-style-type: none"> <li>The number of indoor units was too many when automatic address setting was performed.</li> <li>After initial communications were completed, an unrecognized unit was detected.</li> </ul>
Probable cause	<ol style="list-style-type: none"> <li>The number of indoor units set at the indoor unit quantity setting SW (S004, S005) on the outdoor unit PCB is less than the number set.</li> <li>The inter-unit control wiring is wired incorrectly.</li> </ol>
Check	<ol style="list-style-type: none"> <li>Refer to the test run servicing materials and check the number of indoor units that is set.</li> <li>Check the inter-unit control wiring at the indoor and outdoor units.</li> </ol>
Correction	After correcting the indoor unit quantity setting or the inter-unit control wiring, perform automatic address setting again.
Example	—
Notes	—

### E20 Alarm

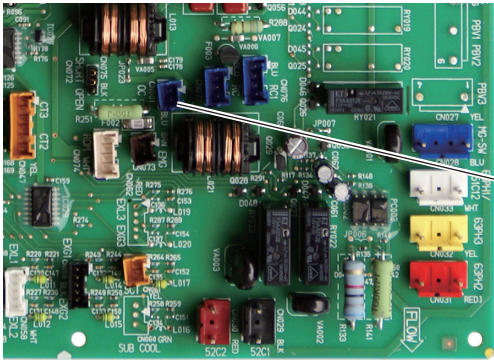
Alarm code	E20
Alarm meaning	No indoor units at automatic address setting.
Alarm conditions	When automatic address setting was performed, no indoor units were recognized.
Probable cause	<ol style="list-style-type: none"> <li>The inter-unit control wiring from the outdoor unit to the indoor units has been cut.</li> <li>Serial connector 1 (CN001) is disconnected at the outdoor unit.</li> <li>The power is OFF at all indoor units in the system.</li> </ol>
Check	<ol style="list-style-type: none"> <li>Check whether the inter-unit control wiring from the outdoor unit to the indoor units is cut.</li> <li>Check whether serial connector 1 (CN001) is disconnected at the outdoor unit.</li> <li>Check the power at the indoor units.</li> </ol>
Correction	(1) Reconnect the inter-unit control wire from the outdoor unit to the indoor unit.
Example	—
Notes	<p>Position of serial connector CN001 on 2WAY</p>  <p>OC CN001</p>

6

### E24 Alarm

Alarm code	E24
Alarm meaning	Outdoor unit (INV) failed to receive communications from other outdoor unit (constant-speed).
Alarm conditions	After initial communications were completed, communications from an outdoor unit stopped.
Probable cause	<ol style="list-style-type: none"> <li>After initial communications were completed, the control wiring between main and sub outdoor units was cut.</li> <li>After initial communications were completed, the outdoor unit power was turned OFF.</li> </ol>
Check	—
Correction	—
Example	—
Notes	—

## 4. 2WAY Alarm Codes

### E25 Alarm

<b>Alarm code</b>	<b>E25</b>
Alarm meaning	Outdoor unit address setting failure (duplication)
Alarm conditions	Communication by outdoor unit main-sub control wiring was received that contained the same address as that unit 5 times or more within 3 minutes.
Probable cause	The unit number is set incorrectly.
Check	Check the unit number again.
Correction	Correct the incorrect unit number setting.
Example	—
Notes	Recovery from this alarm occurs automatically (when communication that contains the same address is not received for 3 minutes).

### E26 Alarm

<b>Alarm code</b>	<b>E26</b>
Alarm meaning	Mismatch in outdoor unit quantity
Alarm conditions	After power initialization, the set outdoor unit quantity did not match the number of outdoor units detected on the outdoor unit main-sub control wiring for 3 minutes or longer.
Probable cause	(1) The outdoor unit quantity is set incorrectly. (2) The outdoor unit main-sub control wiring is cut.
Check	(1) Check the outdoor unit quantity setting again. (2) Check the outdoor unit main-sub control wiring.
Correction	(1) Correct the incorrect outdoor unit quantity setting. (2) Repair the outdoor unit main-sub control wiring.
Example	—
Notes	Recovery from this alarm occurs automatically (when the set outdoor unit quantity matches the number of outdoor units detected on the outdoor unit main-sub control wiring).

### E29 Alarm

<b>Alarm code</b>	<b>E29</b>
Alarm meaning	Outdoor unit failed to receive communication from outdoor unit (main).
Alarm conditions	Outdoor unit communications from outdoor unit (main) were interrupted for 3 minutes or longer.
Probable cause	(1) After initial communications were completed, the outdoor unit main-sub control wiring was cut. (2) After initial communications were completed, the RC connector became disconnected. (3) The power at the outdoor unit (main unit) is turned OFF.
Check	(1) Check the outdoor unit main-sub control wiring. (2) Check the RC connectors. (3) Check the power at the outdoor unit (main).
Correction	(1) Repair the outdoor unit main-sub control wiring. (2) Correct the RC connector connection. (3) Turn ON the outdoor unit (main) power.
Example	—
Notes	—

### E31 Alarm

<b>Alarm code</b>	<b>E31</b>
Alarm meaning	Communication error between two microcomputers on the Control P.C. Board
Alarm conditions	—
Probable cause	When does it occur? (1) When failed in rewriting microcomputer. (2) When the unit power shut down during rewriting microcomputer. (3) When wiring between PCB and ROM writer disconnected.
Check	(1) Rewrite microcomputer again. (2) Switch on the unit power again.
Correction	Replace Control PCB.
Example	—
Notes	—

## 4. 2WAY Alarm Codes

### F04, F05, F22 Alarm

<b>Alarm code</b>	<b>F04, F05, F22</b>
<b>Alarm meaning</b>	Compressor 1 discharge temperature sensor trouble, compressor 2 discharge temperature sensor trouble, Compressor 3 discharge temperature sensor trouble.
<b>Alarm conditions</b>	<p>(1) Discharge temp. of 100°C or higher was detected 20 minutes or more after that compressor stopped operating.</p> <p>(2) Discharge temp. of 70°C or higher was detected after all compressors had been stopped for 60 minutes or longer.</p> <p>(3) A/D step is 10 steps or less (short circuit).</p>
<b>Probable cause</b>	<p>(1) Sensor malfunction</p> <ul style="list-style-type: none"> <li>• Sensor element malfunction</li> <li>• Sensor wiring is partially disconnected, resulting in increased electrical resistance.</li> </ul> <p>☆ This alarm does not occur when the wiring is cut or when the connector is not connected to the outdoor unit PCB.</p> <p>(2) Crossed wiring or installation error</p> <ul style="list-style-type: none"> <li>• The discharge temperature sensor of that compressor is connected to the discharge tube of the other compressor.</li> <li>• The connector for the discharge temperature sensor of the problem compressor is connected to the outdoor unit PCB connector for the other compressor.</li> </ul> <p>(3) Outdoor unit PCB failure</p> <p>(4) The check valve on the discharge tube for that compressor is wet.</p> <p>(5) An air short blockage in the area around the outdoor unit has increased the outdoor unit ambient temperature, reducing the cooling effects after the compressor stops.</p> <p>(6) There is a cause that results in P03, P17, or P02 alarm.</p> <p>(7) Electrical noise</p>
<b>Check</b>	<p>(1) Sensor malfunction and outdoor unit PCB failure</p> <p>Trouble:</p> <ul style="list-style-type: none"> <li>• Constantly indicates a high temperature.</li> <li>• When monitoring software or other means are used for monitoring, the discharge temperature at times fluctuates suddenly and wildly.</li> <li>• In some cases, the precise temperature may not be known, even when monitoring software is used.</li> </ul> <p>Check:</p> <ul style="list-style-type: none"> <li>• Wiggle the sensor and check whether the trouble continues.</li> <li>• Check whether the connector is partially disconnected from the PCB.</li> </ul> <p>☆ An F04 alarm will not result if the connector is completely disconnected (circuit is open).</p> <ul style="list-style-type: none"> <li>• If the cause is still uncertain, check the following to determine whether a sensor or PCB failure has occurred.</li> </ul> <p>Step 1: Connect the other compressor discharge sensor, or a discharge sensor where the F04 alarm has not occurred, to the connector for this compressor on the PCB. Measure the temperature at the same point (a location where temperature fluctuations are small), and check whether there is a temperature difference.</p> <p>Difference → A PCB or sensor failure is possible.          No difference → PCB and sensor are normal.</p> <p>Step 2: If an abnormality was found at Step 1, connect the problem compressor sensor to the other compressor connector on the PCB, or to the PCB connector of a device where the F04 alarm has not occurred. Measure the temperature at the same point (a location where temperature fluctuations are small), and check whether there is a temperature difference.</p> <p>Difference → Sensor failure.          No difference → PCB failure.</p> <p>☆ It is convenient at this time to have a discharge temperature sensor on hand.</p> <p>(2) Crossed wiring or installation error</p> <p>Trouble: Although the other compressor is operating and this compressor is stopped, the discharge temperature of the other compressor does not increase and the discharge temperature of this compressor rises.</p> <p>* The discharge temperature remains high immediately after the compressor stops. Wait for some time after the compressor stops and observe.</p> <p>Check: Check for crossed wiring and installation errors.</p>

Continued



## 4. 2WAY Alarm Codes

Check	<p>(3) Leakage from the discharge tube check valve          Trouble: Although the other compressor is operating and this compressor is stopped, the discharge temperature of this compressor rises together with the temperature of the other compressor.</p> <p>(4) The ambient temperature around the outdoor unit when it is stopped is 43 °C or higher.</p> <p>(5) If the cause is still unknown after checking the above, then it is possible that electrical noise is the cause of the trouble. It is necessary to provide a line filter or carry out other noise countermeasures.</p>
Correction	<p>(1) Replace the sensor.          (2) Replace the outdoor unit PCB.          (3) Carry out noise countermeasures.          (4) Repair the refrigerant tubing.          (5) Adjust the amount of refrigerant.          (6) Correct the trouble.</p>
Example	(1) Sensor wiring is partially cut.
Notes	<p>This alarm does not indicate that the sensor is disconnected.</p> <p>In order to prevent overheating during operation, the outdoor units in this system will not allow a compressor to start if the discharge temperature does not decrease while the compressor is stopped. If a sensor malfunction results in continuous detection of a high discharge temperature, then the compressor may stop for no apparent reason. The purpose of this alarm is to facilitate identification of the problem in this case.</p>

### F06, F23 Alarm

<b>Alarm code</b>	<b>F06, F23</b>
Alarm meaning	Gas temperature sensor trouble at outdoor heat exchanger 1; Gas temperature sensor trouble at outdoor heat exchanger 2.
Alarm conditions	<p>(1) A/D step is 10 steps or less (short circuit).          (2) A/D step is 1014 steps or more (open circuit).</p>
Probable cause	<p>(1) Sensor malfunction (including connector)          (2) PCB malfunction</p>
Check	<p>(1) Measure the sensor resistance. Check that the sensor is operating normally.          (2) Use a remote controller monitor or PC monitor to check the temperature that is recognized by the microcomputer.</p>
Correction	—
Example	—
Notes	—

### F07, F24 Alarm

<b>Alarm code</b>	<b>F07, F24</b>
Alarm meaning	Liquid temperature sensor trouble at outdoor heat exchanger 1; Liquid temperature sensor trouble at outdoor heat exchanger 2.
Alarm conditions	<p>(1) A/D step is 10 steps or less (short circuit).          (2) A/D step is 1014 steps or more (open circuit).</p>
Probable cause	<p>(1) Sensor malfunction (including connector)          (2) PCB malfunction</p>
Check	<p>(1) Measure the sensor resistance. Check that the sensor is operating normally.          (2) Use a remote controller monitor or PC monitor to check the temperature that is recognized by the microcomputer.</p>
Correction	—
Example	—
Notes	—



## 4. 2WAY Alarm Codes

## F08 Alarm

Alarm code	F08
Alarm meaning	Outdoor air temperature sensor trouble
Alarm conditions	(1) A/D step is 10 steps or less (short circuit). (2) A/D step is 1014 steps or more (open circuit)
Probable cause	(1) Sensor malfunction (including connector) (2) PCB malfunction
Check	(1) Measure the sensor resistance. Check that the sensor is operating normally. (2) Use a remote controller monitor or PC monitor to check the temperature that is recognized by the microcomputer.
Correction	—
Example	—
Notes	—

## F12 Alarm

Alarm code	F12
Alarm meaning	Compressor intake temperature sensor trouble
Alarm conditions	(1) A/D step is 10 steps or less (short circuit). (2) A/D step is 1014 steps or more (open circuit)
Probable cause	(1) Sensor malfunction (including connector) (2) PCB malfunction
Check	(1) Measure the sensor resistance. Check that the sensor is operating normally. (2) Use a remote controller monitor or PC monitor to check the temperature that is recognized by the microcomputer.
Correction	—
Example	—
Notes	—

## 4. 2WAY Alarm Codes

### F16 Alarm

Alarm code	F16
Alarm meaning	High-pressure sensor trouble (abnormal rise in high pressure) (In some cases this may not be the result of a high-pressure sensor malfunction.)
Alarm conditions	<ul style="list-style-type: none"> <li>• High-pressure SW activated although the detected pressure was lower (3.03 MPa or below) than the high-pressure SW activation pressure: Undershift</li> <li>• High-pressure SW failed to activate although the detected pressure was higher (3.43 MPa or above) than the high-pressure SW activation pressure: Overshift</li> <li>• The saturation temperature at the detected pressure is 5°C or more below the highest indoor-unit E1 temperature continuously for 30 minutes.</li> <li>• High-pressure sensor disconnected or open circuit.</li> </ul>
Probable cause	<ol style="list-style-type: none"> <li>(1) High-pressure sensor malfunction</li> <li>(2) Failure to connect the connector to the outdoor unit PCB</li> <li>(3) Failure to open the service valve</li> <li>(4) Clogged tubing</li> <li>(5) Valve leakage</li> <li>(6) Over-charging</li> <li>(7) Outdoor unit PCB failure</li> <li>(8) Electrical noise</li> </ol>
Check	<ol style="list-style-type: none"> <li>(1) High-pressure sensor failure                             <ul style="list-style-type: none"> <li>• Check the sensor resistance value. (Use a tester and measure the resistance between sensor No. 1 and No. 3) Resistance of less than 10kΩ indicates a short circuit or other trouble. Resistance of 10kΩ - 200kΩ is normal. Resistance of more than 200kΩ indicates an open circuit or other trouble.</li> <li>• Connect a gauge to the high-pressure outlet and check for changes in the value displayed by the monitoring software, and for large deviation of the gauge pressure.</li> <li>• During heating, check whether the temperature is lower than the highest indoor-unit E1 temperature.                                     <ul style="list-style-type: none"> <li>* The pressure detected by the high-pressure sensor is the highest pressure in the system. Therefore during heating the converted saturation temperature will never be lower than any indoor-unit E1 temperature. During cooling this temperature will never be lower than the outdoor unit liquid temperature.</li> </ul> </li> </ul> </li> <li>(2) Failure to open the service valve, clogged tubing, valve leakage, over-charging.                             <p>In all of these cases an alarm occurs when there are rapid pressure fluctuations and tracking of the detected pressure is poor.</p> <ul style="list-style-type: none"> <li>• Check the open/closed status of the valve.</li> <li>• Check for clogging of the tubing.                                     <p>To check for clogging, disconnect the high-pressure sensor from the PCB and check whether the high-pressure SW activates.</p> </li> <li>• Check for valve leakage and over-charging                                     <p>When valve leakage or over-charging occurs, refrigerant is likely to accumulate in the outdoor units or indoor units, resulting in a sudden rise in pressure at start that occurs before the refrigerant in the heat exchanger is discharged.</p> <ul style="list-style-type: none"> <li>* The representative valves to check are the liquid valves and mechanical valves.</li> </ul> </li> </ul> </li> <li>(3) Outdoor unit PCB failure                             <ul style="list-style-type: none"> <li>• The check items are the same as for a high-pressure sensor malfunction. A normal PCB is needed to determine whether the problem is a PCB failure or a pressure sensor malfunction. If an abnormality was found at the check items for a high-pressure sensor malfunction, first try replacing the PCB and check again.                                     <p>Trouble is corrected: Outdoor unit PCB failure  Trouble is not corrected: High-pressure sensor malfunction</p> </li> </ul> </li> </ol>

Continued

## 4. 2WAY Alarm Codes

Correction	<p>(1) Replace the high-pressure sensor. Caution: Because the high-pressure sensor connection employs a Schrader-type valve, it can be removed and replaced. However, the high-pressure sensor can be easily damaged by high voltage; therefore use sufficient caution with regard to static electricity.</p> <p>(2) Replace the PCB.</p> <p>(3) Correct the locations of problems in the refrigeration cycle.</p> <ul style="list-style-type: none"> <li>• Correct locations where clogging or leakage has occurred.</li> <li>• In the case of over-charging, recover refrigerant. (Adjust the amount of refrigerant).</li> </ul> <p>* Guide for over-charging Be sure to connect the gauge to the high-pressure pressure outlet when checking for over-charging.</p> <p>During cooling: The following does not apply when outdoor air temperature is low or when fan speed is controlled. When both compressor 1 and compressor 2 are operating, and the fan mode is 14 (maximum fan speed), then the high pressure saturation temperature should be approximately 15°C above the outdoor air temperature. If it is 5°C or more above this level, then it is possible that over-charging may have occurred.</p> <p>During heating: There is an indoor unit where refrigerant flow is poor (E1 temperature and discharge temperature are low), and the mechanical valve of that unit is opened to 300 pulses or more, and the E1 temperature is close to room temperature. However be aware that this kind of data results often when there is a height difference between indoor units. Reducing the amount of refrigerant will improve the refrigerant flow, however reducing it too much will increase the likelihood of alarms related to low oil level (scroll-side), the low pressure SW, and discharge temperature. Use caution.</p>
Example	This alarm may result when the service valve is closed or when valve leakage (particularly from the mechanical valve) occurs.

### F17 Alarm

<b>Alarm code</b>	<b>F17</b>
Alarm meaning	Low-pressure sensor trouble
Alarm conditions	(1) Sensor short circuit (2) Sensor open circuit
Probable cause	(1) Sensor malfunction (including connector) (2) PCB malfunction
Check	(1) Measure the sensor resistance. Check that the sensor is operating normally. (2) Use a remote monitor or a PC monitor to check the temperature that is recognized by the microcomputer.
Correction	—
Example	—
Notes	—

6

### F31 Alarm

<b>Alarm code</b>	<b>F31</b>
Alarm meaning	Outdoor unit non-volatile memory (EEPROM) trouble
Alarm conditions	(1) Non-volatile memory is not present when power initialization occurs. (2) Read values do not match after writing to non-volatile memory is complete.
Probable cause	(1) Memory was not inserted after the PCB was replaced. (2) The lifetime of the non-volatile memory has been reached. (3) Non-volatile memory is installed incorrectly (wrong direction, bent pins, etc.).
Check	(1) Check the non-volatile memory on the PCB.
Correction	—
Example	—
Notes	—

## 4. 2WAY Alarm Codes

### H11, H12, H21, H22 Alarm

Alarm code	H11, H12, H21, H22
Alarm meaning	H11: Constant speed compressor 2 overcurrent alarm H12: Constant speed compressor 2 lock current alarm H21: Constant speed compressor 3 overcurrent alarm H22: Constant speed compressor 3 lock current alarm
Alarm conditions	Hx1: During operation, the compressor current value exceeded 12 A for 30 seconds or longer. However this alarm is not detected for 4 seconds after the compressor starts. Hx2: During operation, the compressor current value exceeded 14 A for 4 seconds or longer. However this alarm is not detected for 2 seconds after the compressor starts.
Probable cause	(1) Compressor failure (locked or partially locked) (2) CT circuit failure (including cut wiring) (3) Missing power phase (4) Low power voltage (5) PCB failure
Check	(1) Compressor failure (partially locked) Trouble: Current value during operation greatly exceeds the value shown above. Check: When the current for each phase is measured with a clamp meter or similar instrument, check that the current value for all phases is not high. If MG was forced ON (use caution), check that compressor noise will not occur or the compressor will not run with a groaning sound. (2) CT circuit failure, PCB failure Trouble: Check: <ul style="list-style-type: none"> <li>• Check for poor connector contact.</li> <li>• Check the continuity of the CT circuit.</li> <li>• Install a normal CT in place of this CT and check. If current is detected, then the PCB can be judged OK.                              →CT circuit failure</li> <li>• Check that current is flowing in the phase where the CT circuit is connected.                              →Check voltage and current.</li> </ul> (3) Missing power phase Trouble: This alarm primarily occurs when the T-phase is missing. When the R-phase or S-phase is missing, CT trouble or PCB continuity trouble occur. However this may not be true in the case of a missing phase caused by magnet SW trouble. Check: There is the possibility of a magnet SW failure. Therefore, check the phase voltage at a location that is as close to the compressor as possible. (4) Low power voltage Trouble: In most cases, this occurs when another constant-speed compressor (including compressors in other units) or other device starts. It also occurs when the power wiring is extremely long. Check: Check the voltage between each of the phases. However if this trouble occurs when other devices or compressors start, then an oscilloscope is required. (5) PCB failure Trouble: Check: Check that the current value measured with the clamp meter is not lower than the value measured with the PC or remote controller. (6) If the cause is still unknown after checking the above, then it is possible that noise is the cause of the trouble. It is necessary to connect a PC or other instrument.
Correction	(1) Replace the compressor. (2) Replace the CT circuit. (3) Repair the power circuit. (4) Adjust the primary-side power. Repair the power wiring. (5) Replace the outdoor unit PCB. (6) Correct the trouble. * In the case of a compressor failure, it is likely that steps must be taken to correct the cause of the compressor failure (such as liquid back-up) in order to prevent recurrence. Be sure to check that there is no cause which may result in compressor locking.
Example	—

## 4. 2WAY Alarm Codes

### H03, H13, H23 Alarm

Alarm code	H03, H13, H23
Alarm meaning	Compressor 1 CT sensor disconnected or short-circuit; Compressor 2 CT sensor disconnected or short-circuit; Compressor 3 CT sensor disconnected or short-circuit
Alarm conditions	Current value at compressor 1 was 18 A or less, and at compressors 2 and 3 was 2 A or less when 2 seconds or more had passed after the compressor began operation and output. * No current is detected even though the compressor is operating.
Probable cause	(1) CT circuit failure (including cut wiring, etc.) (2) Disconnected CT circuit connector (3) Missing phase where CT circuit is connected (4) This CT circuit is connected to the connector of the other CT circuit. (5) PCB failure (6) Electrical noise
Check	(1) CT circuit failure, PCB failure Trouble: • Current value during compressor operation is below the threshold value. Check: • Check that the connector is not disconnected. • Check the continuity of the CT circuit. • Install a normal CT in place of this CT and check. If current is detected, then the PCB can be judged OK. →CT circuit failure • Check that current is flowing in the phase where the CT circuit is connected. →Check voltage and current. (2) Crossed wiring or installation error Trouble: When the compressor is stopped, the current value at the other compressor is high. ☆ When this type of condition occurs, seizing-detection control takes priority. (3) If the cause is still unknown after checking the above, then it is possible that noise is the cause of the trouble. It is necessary to connect a PC or other instrument.
Correction	(1) Replace the CT circuit. (2) Replace the outdoor unit PCB. (3) Correct the problem.
Example	(1) The connector was not inserted after the PCB was replaced.
Notes	Use a normal CT as a tool to determine whether the trouble is a PCB failure or CT failure.

### H05, H15, H25 Alarm

Alarm code	H05, H15, H25
Alarm meaning	Compressor 1 discharge temperature sensor disconnected; Compressor 2 discharge temperature sensor disconnected; Compressor 3 discharge temperature sensor disconnected
Alarm conditions	• This alarm occurs when the discharge sensor temperature detector is not inserted into the tube's sensor holder, or when the sensor itself has suffered some kind of malfunction other than a cut wire. • When outdoor air temperature is 10°C or higher: Alarm occurs if the temperature detected by the discharge sensor has changed by less than 2°C when the compressor has operated for 10 minutes immediately after start. • When outdoor air temperature is below 10°C: Alarm occurs if the temperature detected by the discharge sensor has changed by less than 2°C when the compressor has operated for 30 minutes immediately after start.
Probable cause	(1) Discharge sensor temperature detector is not inserted into the tube's sensor holder. (2) Discharge sensor itself has suffered some kind of malfunction other than a cut wire.
Check	(1) Check that the discharge temperature sensor is inserted into the sensor holder. (2) Check that sufficient heat-conducting putty is applied. (3) Remove the discharge sensor from the sensor holder and expose the sensor to the outside air for approximately 5 minutes. Check that the temperature detected by the sensor changes to match the outside air temperature. (However the sensor cannot detect temperatures at or below 0 °C.)
Correction	(1) Install the sensor into the holder, and apply sufficient heat-conducting putty. (2) If the sensor is malfunctioning, replace it.
Example	
Notes	The discharge temperature sensor is generally a sensor intended for accurate detection of high temperatures. Therefore, it will not accurately detect the temperature if the temperature at the measurement point is 20 °C or below.

## 4. 2WAY Alarm Codes

### H06 Alarm

Alarm code	H06
Alarm meaning	Low-pressure switch activated
Alarm conditions	<p>A report occurs during A/C operation when the low-pressure sensor installed at constant low-pressure parts detects a pressure of 0.05 MPa or less continuously for 2 minutes, or an instantaneous pressure of 0.02 MPa or less. (These values represent abnormal low pressure which may damage the compressor.)</p> <p>However, the alarm does not actually occur the first 2 times that the above operation takes place. At these times, the outdoor unit is stopped and the conditions are monitored. The alarm occurs when the above operation occurs for the fifth time. The first 4 times before the alarm occurs are called "pre-trip." After pre-trip occurs, if the low-pressure sensor detects a pressure of 0.15 MPa or more for 3 minutes of continuous operation, the pre-trip count is reset to 0.</p> <p>If the low-pressure sensor detects a pressure of 0.16 MPa or less continuously for 30 minutes when the compressor is stopped, an alarm occurs immediately (no pre-trip).</p>
Probable cause	<p>The A/C unit low pressure has dropped to a level that does not occur under ordinary conditions.</p> <ol style="list-style-type: none"> <li>(1) The absolute amount of gas in the system is too low (as a result of insufficient refrigerant charge or leak).</li> <li>(2) The refrigerant has accumulated in the circuit and has not returned to the compressor. Refrigerant has accumulated in a location of one-way flow and cannot escape. High-pressure level is low, resulting in poor flow of refrigerant in the circuit. (A lower high-pressure level results in a smaller difference between low pressure and high pressure, that may be insufficient to cause refrigerant flow.)</li> <li>(3) The refrigerant circuit has become closed, and refrigerant has not returned to the compressor. In some cases when moisture enters the refrigerant circuit, it can freeze at the low-pressure locations and the resulting ice can block the circuit.</li> </ol> <p>☆ If the alarm occurs when there is sufficient refrigerant in the system ((1) and (3)), liquid refrigerant has definitely accumulated somewhere in the system. Liquid refrigerant generally accumulates in high-pressure locations. In this case the high pressure gradually increases (however it may not increase if the location where the liquid accumulates is sufficiently large). Depending on the refrigerant saturation temperature, it may also accumulate in low pressure locations. In this case the high pressure is unlikely to increase.</p>
Check	<ol style="list-style-type: none"> <li>(1) Check that the service valve is open.</li> <li>(2) Check that none of the valves (solenoid valves, mechanical valves) in the main refrigerant circuit is closed due to an operation failure.</li> <li>(3) Check that there is no possibility of foreign objects or water having entered the refrigerant circuit.</li> <li>(4) Check that valve leakage at a stopped sub unit has not resulted in accumulation of refrigerant at that sub unit.</li> <li>(5) Check that no refrigerant leakage has occurred.</li> </ol>
Correction	<ol style="list-style-type: none"> <li>(1) If there was a valve operation failure, in general it is necessary to replace the valve.</li> <li>(2) If a foreign object or moisture has entered the circuit, install a strainer or dry core (depending on the degree of the problem).</li> <li>(3) If refrigerant has leaked into stopped sub units, it is likely that valve leakage has occurred. The valve must be replaced.</li> </ol>
Example	
Notes	

## H08, H27, H28 Alarm

<b>Alarm code</b>	<b>H08, H27, H28</b>
Alarm meaning	Trouble (open circuit) with the oil sensor (connection) at compressor 1, compressor 2, or compressor 3
Alarm conditions	This alarm occurs when a connector connection (pins 1 and 2 for compressor 1, pins 4 and 5 for compressor 2, and pins 7 and 8 for compressor 3) is open.
Probable cause	Disconnected connector
Check	Check that the connector is securely connected.
Correction	(1) Connect the connector. (2) Correct the connection at connector pins 4 and 5.
Example	—
Notes	



## 4. 2WAY Alarm Codes

### H31 Alarm

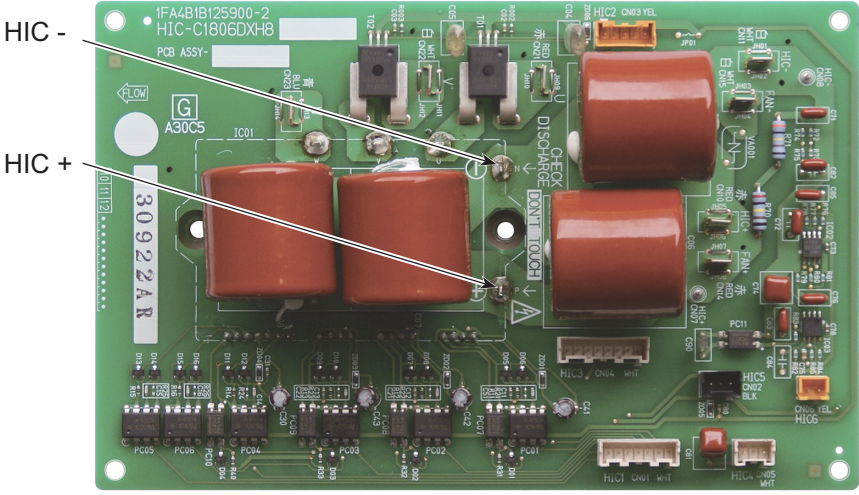
<b>Alarm code</b>	<b>H31</b>
<b>Alarm meaning</b>	HIC trouble alarm
<b>Alarm conditions</b>	This alarm occurs when the microcomputer identifies a trouble signal (indicating abnormal HIC temperature or other trouble) from the HIC. The HIC judges the current and temperature, and outputs the trouble signal. In general this indicates trouble with the HIC itself.
<b>Probable cause</b>	Overcurrent in HIC circuit, and the resultant abnormal heating, caused by HIC failure
<b>Check</b>	Check the power wiring and connector wiring. If the wiring and connectors are normal, use a tester to measure the resistance between the compressor HIC power (HIC+) and ground (HIC-). If there is a short-circuit, there is an HIC malfunction.
	 <p style="text-align: center;"><b>HIC PCB</b></p>
<b>Correction</b>	If an HIC failure is found, replace the PCB.
<b>Example</b>	—
<b>Notes</b>	Turn OFF the power, and check the continuity of HIC+ and HIC- on the HIC PCB.

### L04 Alarm

<b>Alarm code</b>	<b>L04</b>
<b>Alarm meaning</b>	Outdoor system address duplication
<b>Alarm conditions</b>	Communication by inter-unit control wiring was received that contained the same address as that unit 5 times or more within 3 minutes.
<b>Probable cause</b>	Incorrect outdoor system address settings
<b>Check</b>	Check the system address settings again.
<b>Correction</b>	Correct the system address settings.
<b>Example</b>	—
<b>Notes</b>	Recovery from this alarm occurs automatically (when communication that contains the same address as that unit is not received for 3 minutes after detection).



## 4. 2WAY Alarm Codes

### L10 Alarm

Alarm code	L10
Alarm meaning	Outdoor unit capacity not set
Alarm conditions	The outdoor unit capacity has not been set, or the setting is not allowed by the system.
Probable cause	This alarm occurs because the capacity has not been set.
Check	Connect the outdoor unit maintenance remote controller. On the outdoor unit EEPROM detailed setting mode screen, check the value for the outdoor unit capacity (item code 81). Check that it is not set to "0" or to a capacity that is not allowed.
Correction	If item code 81 is incorrect, use the outdoor unit maintenance remote controller and set it correctly. * After changing the setting, be sure to reset both the indoor and outdoor power.
Example	—
Notes	The outdoor unit maintenance remote controller is required in order to set the capacity in the outdoor unit EEPROM.

### L17 Alarm

Alarm code	L17
Alarm meaning	Outdoor unit model mismatch
Alarm conditions	This alarm occurs when a unit other than a R410A refrigerant model is connected.
Probable cause	(1) A unit that uses R407C refrigerant, or a R22 model unit, was connected by mistake. (2) The connected unit is correct, however the refrigerant type setting in the outdoor unit EEPROM (item code 80) is incorrect.
Check	(1) Check the refrigerant type at the connected unit. (2) Use the outdoor unit maintenance remote controller and check the item code 80 refrigerant type. If the setting is incorrect, change it to R410A.
Correction	—
Example	—
Notes	The outdoor unit maintenance remote controller is required in order to set the refrigerant type in the outdoor unit EEPROM.

### L18 Alarm

Alarm code	L18
Alarm meaning	4-way valve operation failure
Alarm conditions	During heating operation (Comp. ON), the highest detected temperature at an outdoor unit heat exchanger (EXG 1, EXG 2, EXL 1, or EXL 2) was 20°C or more above the outdoor air temperature (Air Temp.) continuously for 5 minutes or longer, or the detected suction temperature (SCT) was 20°C or more above the outdoor air temperature continuously for 5 minutes or longer.
Probable cause	(1) The 4-way valve connector (20S CN022) has become disconnected from the control PCB. (2) The 4-way valve circuit is locked (malfunctioning).
Check	(1) Check the 4-way valve connector (20S CN022). (2) If the connector is normal, check the 4-way valve wiring and the PCB circuit.
Correction	If the connector is normal, correct or replace the problem locations.
Example	—
Notes	—

### P02 Alarm

Alarm code	P02
Alarm meaning	Compressor thermal protector is activated. (trip only and no alarm)
Alarm conditions	When the current is not detected over 4 seconds long after the compressor ON.
Probable cause	Activating condition of the compressor thermal protector (The voltage is more than 260V or less than 160V between L and N phase.)
Check	(1) Check the constant speed compressor. (2) Check the current transformer.
Correction	• Put the constant speed compressor OFF over 60 minutes and cool the thermostat. • Replace defective parts with new ones.
Example	—
Notes	—

## 4. 2WAY Alarm Codes

### P03, P17, P18 Alarm

Alarm code	P03, P17, P18
Alarm meaning	Compressor 1 discharge temperature trouble; Compressor 2 discharge temperature trouble; Compressor 3 discharge temperature trouble
Alarm conditions	Temperature is 106°C or higher and pre-trip stop has occurred. The alarm occurs when pre-trip stop occurs more than once. However the pre-trip counter is cleared if the compressor operates continuously for a specified length of time.
Probable cause	<ol style="list-style-type: none"> <li>(1) Clogging of liquid valve capillaries</li> <li>(2) Insufficient amount of refrigerant (including trouble resulting from an insufficient initial charge and from gas leakage)</li> <li>(3) Blocking of low-pressure parts caused by intrusion of foreign objects (moisture, scale, etc.)</li> <li>(4) Crossing (tubing or PCB connectors) with the other compressor thermistor</li> <li>(5) Expansion valve operation failure</li> <li>(6) Accumulation of refrigerant at stopped outdoor units</li> <li>(7) Compressor discharge sensor failure</li> <li>(8) PCB failure (A/D conversion failure)</li> <li>(9) Electrical noise</li> </ol>
Check	<ol style="list-style-type: none"> <li>(1) Clogging of capillaries            Trouble: Compressor discharge temperature does not decrease even when the liquid valve is ON.            Check: When the liquid valve is operating and the liquid valve is ON, check that the secondary side of the liquid capillaries is cold.</li> <li>(2) Insufficient refrigerant            Trouble: Liquid effectiveness is poor.            Check: Check whether or not the superheating temperature is declining if the evaporator mechanical valve is opened to 300 pulses or more (after checking for foreign object intrusion).</li> <li>(3) Foreign object intrusion            Trouble: Liquid valve effectiveness is poor.            Check: Check that there is no difference in the condensation or frost conditions between the strainer primary-side and secondary-side tubing.</li> <li>(4) Crossed thermistor            Trouble: The discharge temperature of the other compressor is high although only this compressor is operating.            When the liquid valve turns ON, the discharge temperature of the other compressor decreases.</li> <li>(5) Accumulation of refrigerant in stopped outdoor units            Trouble:           <ul style="list-style-type: none"> <li>• System is OK when all outdoor units are operating, however symptoms of insufficient gas occur when a certain outdoor unit is stopped.</li> <li>• Condensation or frost is visible up to the top of the accumulator of the stopped outdoor unit.</li> <li>• After an outdoor unit stops, there is the sound of refrigerant flowing into an outdoor unit that was stopped for a long time.</li> <li>• When an outdoor unit starts after being stopped for a long time, the start is accompanied by much vibration.</li> </ul>           Check:           <ul style="list-style-type: none"> <li>• Representative parts include the liquid capillaries (secondary side of capillaries will be cool during cooling operation), mechanical valve, mechanical valve bypass check valve (sound of refrigerant flow can be heard, and stops when the liquid valve is closed), hot gas defrost valve (if valve secondary side remains hot even after much time has passed, be careful not to mistake transmitted heat for a valve failure).</li> <li>• Ice is growing on the lower parts of some outdoor unit heat exchangers but not on others.                Because this trouble may occur even in outdoor units with a high operating rate under conditions of insufficient gas, caution is needed.</li> </ul> </li> <li>(6) Sensor failure            Check:           <ul style="list-style-type: none"> <li>• This alarm is likely to occur when wiring is partially cut. (It is difficult to identify, even when continuity is checked.) The detected discharge temperature is high.</li> <li>• Although such conditions rarely occur, a P02 alarm is likely if the detected discharge temperature is low.</li> <li>• Replace the sensor with another discharge sensor and compare the temperature conditions.</li> </ul> </li> <li>(7) If the cause is still unknown after checking the above, then it is possible that electrical noise is the cause of the trouble.</li> </ol>
Correction	<ol style="list-style-type: none"> <li>(1) Replace the sensor.</li> <li>(2) Replace the outdoor unit PCB.</li> <li>(3) Correct the problem locations.</li> </ol>
Example	All of the probable causes
Notes	Operates continuously for a set length of time. Indicates 2.5 minutes or longer for an inverter unit and 30 seconds or longer for a constant-speed compressor.

## 4. 2WAY Alarm Codes

### P04 Alarm

Alarm code	P04
Alarm meaning	High-pressure switch activated.
Alarm conditions	The operation of the electronic circuit in the high-pressure switch may short-circuit the terminal depending on the pressure. A pressure of 3.3 MPa or above will short-circuit the terminal. Once the terminal is short-circuited, it will remain in that state until the pressure goes below 2.6 MPa.
Probable cause	<ol style="list-style-type: none"> <li>(1) Failure of the check valve in the compressor discharge tube.</li> <li>(2) The service valve is closed.</li> <li>(3) Clogging of the outdoor heat exchanger during cooling.</li> <li>(4) An air short in the outdoor unit during cooling.</li> <li>(5) Failure of the outdoor fan during cooling.</li> <li>(6) Clogging of the air filter in the indoor unit during heating.</li> <li>(7) An air short in the indoor unit during heating.</li> <li>(8) Failure of the indoor fan during heating.</li> <li>(9) Clogging of the refrigerant circuit.</li> <li>(10) Failure of the mechanical valve.</li> <li>(11) Failure of the solenoid valve kit.</li> <li>(12) Too much refrigerant has been charged.</li> <li>(13) Failure of the high-pressure switch.</li> </ol>
Check	<ol style="list-style-type: none"> <li>(1) Make sure that the high-pressure switch connector has been properly connected.</li> <li>(2) If the high-pressure switch is properly connected, connect a high-pressure gauge to the high-pressure outlet port and monitor the pressure during operation to check the pressure when the high-pressure switch is activated. Check valve failure is likely if the pressure is less than 3.3 MPa. The following describes checks to be made when the pressure is high.</li> <li>(3) During cooling, check whether the outdoor unit heat exchanger is clogged. Remove any foreign material that prevents ventilation.</li> <li>(4) During cooling, check whether an air short blockage has occurred in the outdoor unit. The system is operating normally unless the temperature around the outdoor unit is excessively high.</li> <li>(5) During cooling, check for outdoor fan failure. Check whether the screws securing the fan are loose and whether the fan connector in the outdoor unit PCB is properly connected.</li> <li>(6) During heating, check whether the air filters in the indoor unit are clogged. If clogged, clean the filters.</li> <li>(7) During heating, check whether an air short blockage has occurred in the indoor unit. The system operates normally unless the temperature around the indoor unit is excessively high.</li> <li>(8) During heating, check for indoor fan failure.</li> <li>(9) Check whether the refrigerant circuit is clogged. Check that all service valves are closed. Check whether welded locations are clogged.</li> <li>(10) Check for mechanical valve failure. Check whether the mechanical valves make a clattering sound when the power is reset. Since the mechanical valve in the indoor unit is in a location that makes aural inspection difficult, use an electric means to check. Check that the connector pin of the mechanical valve on the PCB outputs 4 V. In addition, check that the coil resistance of the mechanical valve is several tens of <math>\Omega</math>.</li> <li>(11) Check for solenoid valve kit failure. Removing a coil that is on will result in a clicking sound. Also, removing a coil that is off will not produce such a sound.</li> <li>(12) Check whether too much refrigerant has been charged. Too much refrigerant has been charged if the sub-cool temperature of the condenser is 15°C or more.</li> </ol>
Correction	Replace damaged components and correct the amount of charged refrigerant.
Example	—
Notes	—

### P05 Alarm

Alarm code	P05
Alarm meaning	Reverse phase (or missing phase) detected
Alarm conditions	This alarm occurs when a reverse phase or missing phase is detected in the L1-L2-L3-N phases.
Probable cause	Reverse phase or missing phase in the L1-L2-L3-N phases
Check	Check the wiring at the power terminal plate.
Correction	Switch the phases and reinsert. Check if the result is OK.
Example	—
Notes	—

## 4. 2WAY Alarm Codes

### P14 Alarm

<b>Alarm code</b>	<b>P14</b>
Alarm meaning	O <sub>2</sub> sensor operation
Alarm conditions	(1) It is judged an error whenever the outdoor unit receives the signal "O <sub>2</sub> Alarm Generated" from the indoor unit. (2) With the indoor unit's EEPROM setting (item code 0B) set to 0001, the EXCT input was shorted.
Probable cause	—
Check and Correction	(1) System configuration 1-1 Is an O <sub>2</sub> sensor being used? If "Yes", see "3-1". If "No", see "2-1". (2) Indoor EEPROM setting 2-1 Is the EEPROM setting, item code 0B, on the indoor control board set to 0001? If "Yes", see "3-1" after modification. If "No", see "4-1". (3) EXCT wiring 3-1 Is the EXCT socket (wire) shorted? If "Yes", Modify the wiring. If "No", see "4-1". (4) Indoor control board 4-1 Is the alarm triggered if the EXCT socket (wire) is disconnected, and the power is reset? If "Yes", see "4-3". If "No", see "4-2". 4-2 Since there is no error, see what happens. 4-3 Indoor control board defective → replace board
Example	—
Notes	—

### P16 Alarm

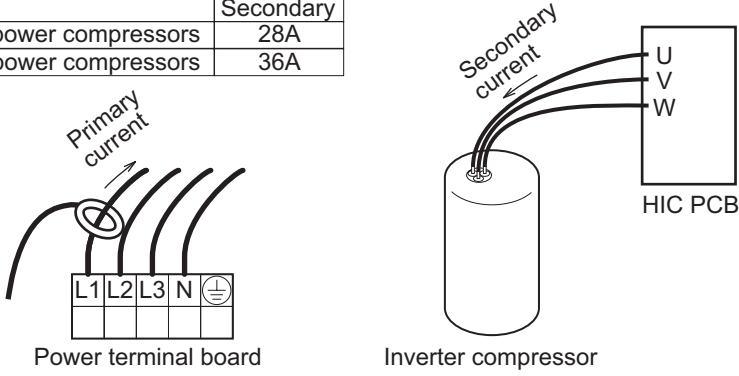
<b>Alarm code</b>	<b>P16</b>															
Alarm meaning	Compressor 1 (INV) overcurrent alarm															
Alarm conditions	This alarm occurs when current trouble or current detection trouble occur (when trouble judgment current is detected in the primary or secondary current, or when an instantaneous secondary current of 18A* or higher is detected). * Changed to output error by current regardless of the inverter frequency. In addition, there are 6 horsepower and 10 horsepower compressors. (1) When more than the over-current values shown in the table were detected in the primary and secondary current. <table border="1" style="margin-left: 20px;"> <thead> <tr> <th></th> <th>Primary</th> <th>Secondary</th> </tr> </thead> <tbody> <tr> <td>6 horsepower compressors</td> <td>18A</td> <td>18A</td> </tr> <tr> <td>10 horsepower compressors</td> <td>21A</td> <td>21A</td> </tr> </tbody> </table> (2) When more than the current values shown in the table are instantly detected in the secondary current. <table border="1" style="margin-left: 20px;"> <thead> <tr> <th></th> <th>Secondary</th> </tr> </thead> <tbody> <tr> <td>6 horsepower compressors</td> <td>28A</td> </tr> <tr> <td>10 horsepower compressors</td> <td>36A</td> </tr> </tbody> </table> 		Primary	Secondary	6 horsepower compressors	18A	18A	10 horsepower compressors	21A	21A		Secondary	6 horsepower compressors	28A	10 horsepower compressors	36A
	Primary	Secondary														
6 horsepower compressors	18A	18A														
10 horsepower compressors	21A	21A														
	Secondary															
6 horsepower compressors	28A															
10 horsepower compressors	36A															
Probable cause	There is a strong possibility of a compressor failure. An alarm occurs for current detection trouble when it is judged that no current is flowing after start (DCCT is damaged). In this case, the cause is a DCCT failure.															
Check	Check the power wiring and connector wiring.															
Correction	It is possible to resolve this trouble by limiting the maximum frequency.															
Example	—															
Notes	—															

## 4. 2WAY Alarm Codes

### P20 Alarm

Alarm code	P20
Alarm meaning	High load alarm
Alarm conditions	The high pressure increase is not rapid but the alarm occurs when the horsepower down does not meet the anticipated time.
Probable cause	(1) Forgot to open the valve. (2) Operation failure of mechanical valve (3) Idle away of outdoor fan
Check	Check the valve, mechanical valve and outdoor fan.
Correction	—
Example	—
Notes	—

### P22 Alarm

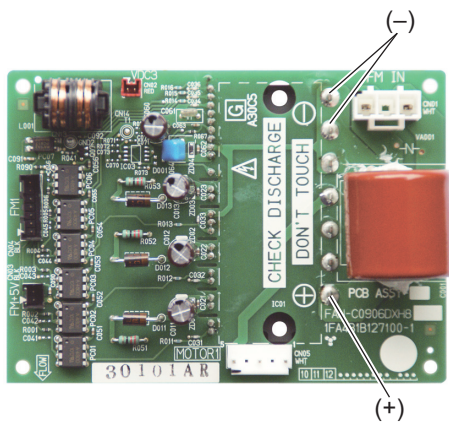
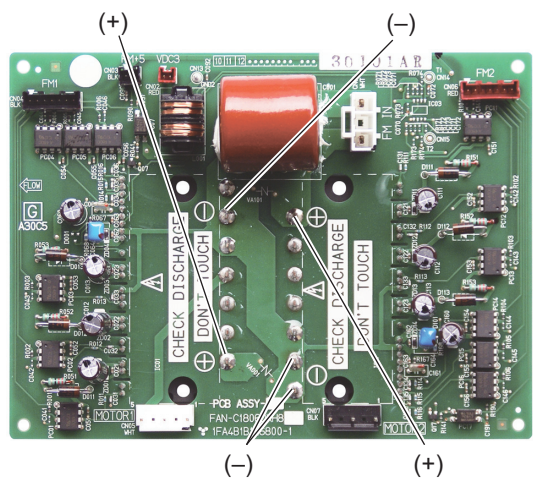
Alarm code	P22
Alarm meaning	Fan motor trouble
Alarm conditions	Fan motor start failure, fan motor Hall IC input failure
Probable cause	Possible causes are a Hall IC input circuit failure and a fan HIC failure.
Check	<p>Check the fan motor wiring, the Hall IC wiring, and the connector connections.</p> <p>If the wiring and connectors are normal, then check that the capacitor of the Hall IC input circuit is securely soldered on the outdoor unit control PCB. Also use a tester and measure the resistance between fan HIC power (HIC+) and ground (HIC-).</p> <p>If there is a short-circuit, there is an HIC malfunction.</p>
	<div style="display: flex; justify-content: space-around; align-items: center;"> <div style="text-align: center;">  <p>Fan PCB FAN-C0906DXH8</p> </div> <div style="text-align: center;">  <p>Fan PCB FAN-C1806DXH8</p> </div> </div>
Correction	<p>If the fan does not start, the below corrections may be effective.</p> <p>(1) If there is a fan HIC failure or circuit failure, replace the PCB.</p> <p>(2) If the fan motor is locked, replace the fan motor.</p>
Example	—
Notes	Turn OFF the power, and check the continuity of “+” and “-” on the fan circuit PCB.

## P29 Alarm

<b>Alarm code</b>	<b>P29</b>
Alarm meaning	Inverter compressor missing phase or lock alarm
Alarm conditions	This alarm may occur at start, and occurs when missing phase or lock is detected, and when a DCCT failure occurs.
Probable cause	Generally this alarm occurs when the refrigerant pressure balance is uneven at start, or when inverter compressor lock occurs, there is a missing phase in the inverter compressor wiring, or a DCCT failure occurs. This can be judged to be starting trouble which is not caused by HIC.
Check	Check the power wiring and connector wiring.
Correction	DCCT failure (replace PCB) or compressor failure
Example	—
Notes	Use a tester to measure the voltage between the DCCT output terminal on the rear of the PCB and the ground. If the voltage is not within 2 – 3 V, then the DCCT has malfunctioned.



**CAUTION**

Currently the blinking inspection display can be displayed only on the wired remote controller and system remote controller.

### Blinking inspection display (1) (Automatic backup)

Alarm code	(Blinking inspection display)
Alarm meaning	Automatic backup is in progress. A/C units can be operated. Status: The compressor at one of the outdoor units where the outdoor unit fan is running should be operating. * Blinking inspection display also occurs when seizing of the compressor magnet SW is detected. Because this may also be the case, refer to "Blinking inspection display (compressor magnet SW seizing detection)."
Alarm conditions	When alarm P16, P22, P29, Hx1, Hx2, or H31 has occurred, correcting the control device (remote controller, etc.) input engages this mode.
Probable cause	Because alarm P16, P22, P29, Hx1, Hx2, or H31 has occurred, check the alarm history then refer to the corresponding items.
Correction	Follow the instructions in the corresponding items to correct the trouble.
Recovery	After repairing the malfunctioning locations, reset the power for the system (all outdoor units). Caution: Automatic backup mode will not be canceled until the power is reset.
Notes	Automatic backup mode is not engaged in cases of alarms other than those listed above. Reasons: <ul style="list-style-type: none"> <li>• There is no need for automatic backup if recovery is possible by correcting the remote controller input.</li> <li>• With alarms for which automatic recovery is possible (such as sensor alarms), the presence of electrical noise may result in a new alarm. However, it is believed that this occurs for a comparatively short time only. In these cases, a mode (automatic backup mode) that limits operation may be engaged.</li> <li>• Control is not possible when a communications system alarm has occurred. Automatic backup mode is not engaged in order to avoid causing secondary damage.</li> </ul>



### Blinking inspection display (2) (compressor magnet SW seizing detection)

Alarm code	(Blinking inspection display)
Alarm meaning	<p>Compressor magnet SW seizing detected</p> <p>Status: Although an outdoor unit exists where the outdoor unit fan is running, no compressors in the system are operating.</p> <p>☆ Because the fan is running only at the outdoor unit where seizing was detected, check the corresponding outdoor unit.</p> <p>* The fan may also run on its own when fan cracking prevention control is in effect or when snowfall sensor input is present. Therefore monitor for approximately 10 minutes if the outdoor unit fans are operating at multiple units.</p>
Alarm conditions	<p>Current is detected in the CT circuit when the compressor is stopped.</p> <p>(1) This control is not engaged for the first 30 seconds after the compressor turns ON → OFF.</p> <p>(2) For 1 minute following the first 30 seconds after the compressor turned ON → OFF, the threshold for the detected current is 10 A or more continuing for 2 seconds.</p> <p>(3) All times other than the above:</p> <ul style="list-style-type: none"> <li>• If the low-pressure SW has not activated, the threshold for the detected current is 7A or more continuing for 5 seconds.</li> <li>• If the low-pressure switch has activated, the threshold for the detected current is 7A or more continuing for 2 seconds.</li> </ul>
Probable cause	<p>(1) Magnet SW malfunction</p> <ul style="list-style-type: none"> <li>• The magnet SW has seized, and the compressor is continuing to run. <ul style="list-style-type: none"> <li>→ Even when the power is turned OFF, the primary side and secondary side contacts remain together.</li> </ul> </li> <li>• The conditions of magnet SW operation are poor (difficult to open). <ul style="list-style-type: none"> <li>→ When a magnet SW is used in a DC circuit, it may be difficult for the SW to open at times. In an AC circuit the magnet SW should open instantaneously as long as the current is within the allowable range. However, this kind of trouble can occur if excessive current flows, and may prevent the SW from opening.</li> </ul> </li> </ul> <p>(2) CT circuit failure or PCB failure (A/D failure)</p> <ul style="list-style-type: none"> <li>• CT circuit contact failure <ul style="list-style-type: none"> <li>→ Check that the connector is not partially disconnected. Wiggle the connector to check the connection.*</li> <li>* These symptoms will not occur if the connector is completely disconnected or the wire is cut. In these cases alarm Hx3 occurs.</li> </ul> </li> <li>• Current of 7A or higher was detected although the compressor was stopped, or a higher current was detected at occasional intervals.</li> <li>• The compressor continues to operate at a time when the outdoor unit should be stopped (such as when all indoor units are stopped). <ul style="list-style-type: none"> <li>→ Check whether or not 200 V is output from the PCB to the magnet SW. If the voltage is output, there is a PCB failure.</li> </ul> </li> </ul> <p>(3) Installation error</p> <ul style="list-style-type: none"> <li>• CT2 connector is connected to the compressor 3 side</li> <li>• CT2 circuit is connected to the compressor 3 side</li> <li>• CT3 connector is connected to the compressor 2 side</li> <li>• CT3 circuit is connected to the compressor 2 side</li> </ul> <p>(4) Electrical noise</p>
Correction	<p>(1) Replace the CT circuit.</p> <p>(2) Replace the magnet SW.</p> <p>(3) Replace the PCB.</p> <p>If the above probable causes are not the cause of the alarm, it is possible that in rare cases the alarm may be caused by the effects of noise. See notes.</p>
Notes	<p>The effects of electrical noise are difficult to identify unless a PC is connected and the conditions are monitored for a long period of time.</p>



## 6. Inspection of Parts

### (1) High-pressure switch (63PH1, 63PH2, 63PH3)

63PH1	Disconnect the CN033 connector (3P, white) from the outdoor unit control panel. Measure the resistance between socket pins 1 and 3. The resistance is OK if the result is 0 Ω.
63PH2	Disconnect the CN031 connector (3P, red) from the outdoor unit control panel. Measure the resistance between socket pins 1 and 3. The resistance is OK if the result is 0 Ω.
63PH3	Disconnect the CN032 connector (3P, yellow) from the outdoor unit control panel. Measure the resistance between socket pins 1 and 3. The resistance is OK if the result is 0 Ω.

### (2) Electronic control valve (MOV1, MOV2, MOV4)

After removing the connector from the PCB, use the following methods to check the valves.

MOV1	<p>Measure the voltage between plug pin 5 and pins 1 through 4 at the CN079 connector (5P, white) on the outdoor unit control PCB. (Because of the pulse output, a simplified measurement method is used. Set the tester to the 12 V range; if the value displayed is approximately 4 V, then the voltage is normal.)</p> <p>When the voltage is normal, measure the resistance between each pair of pins on the electronic control valve connector. The connector is normal if all results (pin 5 – pin 1, pin 5 – pin 2, pin 5 – pin 3, pin 5 – pin 4) are approximately 46Ω. (If the results are 0Ω or ∞, replace the coil.)</p>
MOV2	<p>Measure the voltage between plug pin 5 and pins 1 through 4 at the CN080 connector (5P, red) on the outdoor unit control PCB. (Because of the pulse output, a simplified measurement method is used. Set the tester to the 12 V range; if the value displayed is approximately 4 V, then the voltage is normal.)</p> <p>When the voltage is normal, measure the resistance between each pair of pins on the electronic control valve connector. The connector is normal if all results (pin 5 – pin 1, pin 5 – pin 2, pin 5 – pin 3, pin 5 – pin 4) are approximately 46Ω. (If the results are 0Ω or ∞, replace the coil.)</p>
MOV4	<p>Measure the voltage between plug pin 5 and pins 1 through 4 at the CN082 connector (5P, blue) on the outdoor unit control PCB. (Because of the pulse output, a simplified measurement method is used. Set the tester to the 12 V range; if the value displayed is approximately 4 V, then the voltage is normal.)</p> <p>When the voltage is normal, measure the resistance between each pair of pins on the electronic control valve connector. The connector is normal if all results (pin 5 – pin 1, pin 5 – pin 2, pin 5 – pin 3, pin 5 – pin 4) are approximately 46Ω. (If the results are 0Ω or ∞, replace the coil.)</p>

### (3) Crankcase heater

- Connect a clamp meter to 1 of the 2 crankcase heater wires and measure the current.  
The current is normal if the result is 0.15 A or higher.  
(As a guide, the current should be 0.14 A (180 V) – 0.17 A (220 V).)

When the test pin on the outdoor unit control PCB is short-circuited, each part can be operated individually.

- After turning OFF the main unit power, short-circuit the test pin (CN048, white), then turn the power back ON. Output is performed in the sequence shown in the table below, for 0.5 seconds each.

	Output	Operation		Output	Operation
1	Relay RY012	Supercooling valve 1 (SCV1)	11	Relay RY008	Save valve (SAVE)
2	Relay RY013	Supercooling valve 2 (SCV2) *	12	Relay RY019	Pressure balance valve 2 (PBV2) *
3	Relay RY016	Discharge valve 2 (DCV2) *	13	Relay RY002	Crankcase 2 (CH2)
4	Relay RY015	Discharge valve 1 (DCV1) *	14	Relay RY001	Crankcase 1 (CH1)
5	Relay RY014	Bypass valve (BPV)	15	Relay RY014	Supercooling valve 3 (SCV3) *
6	Relay RY006	Recovery valve (ORVR)	16	Relay RY017	Discharge valve 3 (DCV3) *
7	Relay RY005	Balance valve (BALV)	17	Relay RY020	Pressure balance valve 3 (PBV3) *
8	Relay RY018	Pressure balance valve 1 (PBV1)	18	Relay RY003	Crankcase 3 (CH3)
9	Relay RY011	Refrigerant balance valve (RBV)			
10	Relay RY010	Refrigerant adjustment valve (RCV)			

\* The asterisk (\*) mark stands for the series of "3Way".



