

# Service Manual

## Domestic Hot Water Tank Unit System



**WH-TD20B3E5**  
**WH-TD30B3E5**

### **WARNING**

This service information is designed for experienced repair technicians only and is not designed for use by the general public. It does not contain warnings or cautions to advise non-technical individuals of potential dangers in attempting to service a product. Products powered by electricity should be serviced or repaired only by experienced professional technicians. Any attempt to service or repair the products dealt with in this service information by anyone else could result in serious injury or death.

### **PRECAUTION OF LOW TEMPERATURE**



In order to avoid frostbite, be assured of no refrigerant leakage during the installation or repairing of refrigerant circuit.

## TABLE OF CONTENTS



<b>1. Safety Precautions</b> .....	<b>2</b>	<b>8. Operation Control</b> .....	<b>14</b>
<b>2. Specification</b> .....	<b>4</b>	8.1 Safety Valve .....	14
<b>3. Features</b> .....	<b>5</b>	8.2 Thermostat .....	14
<b>4. Location</b> .....	<b>6</b>	8.3 3-Way Valve .....	14
<b>5. Dimensions</b> .....	<b>7</b>	<b>9. Troubleshooting Guide</b> .....	<b>15</b>
5.1 WH-TD20B3E3.....	7	<b>10. Disassembly Instructions</b> .....	<b>16</b>
5.2 WH-TD30B3E5.....	8	10.1 Replacing the Heating Element.....	16
<b>6. Water Cycle Diagram</b> .....	<b>9</b>	10.2 Replacing the Thermostat.....	16
<b>7. Installation Instruction</b> .....	<b>10</b>	10.3 Replacing the Sacrificial Anode .....	16
7.1 Piping and Wiring Installation.....	10	<b>11. Technical Data</b> .....	<b>17</b>
7.2 Charge the Water .....	13	11.1 Tank Thermistor .....	17
7.3 Examine the Anode once a year .....	13	<b>12. Replacement Parts List</b> .....	<b>18</b>
7.4 Discharge of Water.....	13		
7.5 Precaution on Usage.....	13		

# 1. Safety Precautions





- Read the following “SAFETY PRECAUTIONS” carefully before installation of Domestic Hot Water Tank Unit (hereafter referred to as “Tank Unit”).
- Electrical works and water installation works must be done by licensed electrician and licensed water system installer respectively. Be sure to use correct rating and main circuit for the model installed.
- The caution items stated here must be followed because these important contents are related to safety. The meaning of each indication used is as below. Incorrect installation due to ignorance or negligence of the instructions will cause harm or damage, and the seriousness is classified by the following indications.

 <b>WARNING</b>	This indication shows the possibility of causing death or serious injury
 <b>CAUTION</b>	This indication shows the possibility of causing injury or damage to properties only.



The items to be followed are classified by the symbols:

	Symbol with white background denotes item that is PROHIBITED from doing.
	Symbol with dark background denotes item that must be carried out.

- Carry out test run to confirm that no abnormality occurs after the installation. Then, explain to user the operation, care and maintenance as stated in instructions. Please remind the customer to keep the operating instructions for future reference.
- If there is any doubt about the installation procedure or operation, always contact the authorized dealer for advice and information.

 <b>WARNING</b>	
1. Do not modify the machine, part, material during repairing service.	
2. If wiring unit is supplied as repairing part, do not repair or connect the wire even only partial wire break. Exchange the whole wiring unit.	
3. Must engage an authorized dealer or specialist installation and servicing. If installation or servicing is defective, it will cause water leakage, electrical shock or fire.	
4. Install according to this installation instructions strictly. If installation is defective, it will cause water leakage, electrical shock or fire.	
5. Use the attached accessories parts and specified parts for installation. Otherwise, it will cause the set to fall, water leakage, fire or electrical shock.	
6. Install at a flat horizontal, strong and firm location which is able to withstand the Tank Unit's weight. If the location is slanting, or strength is not enough the set will fall and cause injury.	
7. For electrical work, follow the local national wiring standard, regulation and the installation instruction. An independent circuit and single outlet must be used. If electrical circuit capacity is not enough or defect found in electrical work, it will cause electrical shock or fire.	
8. Only use the supplied and specified installation parts. Else, it may causes Tank Unit vibrate, water leakage, electrical shock or fire.	
9. Utilization in an open water system may lead to excessive corrosion of the water piping, water leakage or under pressure to the Tank Unit.	
10. Do not make any purchase of electrical parts locally for installation, service, maintenance, etc. This should be done by a licensed electrician and an authorized dealer. Otherwise, it may cause electrical shock or fire.	
11. Do not branch the power from terminal block to heater tap. Overloaded terminal block will cause electrical shock or fire.	
12. Keep plastic bag (packaging material) away from small children, it may caused suffocation.	
13. For cold water supply has a backflow regulator, check valve or water meter with check valve, provisions for thermal expansion of water in the hot water system must be provided. Otherwise it will cause water leakage.	
14. The piping installation work must be flushed before Tank Unit is connected to remove contaminants. Contaminants may damage the Tank Unit components.	
15. This installation may be subjected to building regulation approval applicable to respective country that may require to notify the local authority before installation.	
16. The Tank Unit must be shipped and stored in upright condition and dry environment. It may laid on its back when being moved into the building.	
17. Work done to the Tank Unit after remove the front plate cover that secured by screws, must be carried out under the supervision of authorized dealer and licensed.	

 **CAUTION**

- |   |   |
|---|---|
| 1. Installation work.<br>Three people are required to carry out the installation work. The weight of Tank Unit might cause injury if carried by one person.   |   |
| 2. Do not install Tank Unit at place where leakage of flammable gas may occur. In case gas leaks and accumulates at surrounding of the Tank unit, it may cause fire.  |  |
| 3. Carry out drainage piping as mentioned in installation instructions. If drainage is not perfect, water leakage may happen and may cause damage to properties of the user.                                |   |
| 4. Select an installation location where it is accessible for maintenance.  |   |
| 5. Do not install this appliance in a laundry room or other high humidity location. This condition will cause rust and damage to the Tank unit.   |  |
| 6. Make sure the power supply cord does not contact with hot part (i.e. water piping). High temperature may cause insulator of power supply cord damage hence electrical shock or fire.                     |  |
| 7. After installation or servicing, it is obliged to verify correct operation of the Tank Unit. Check the connection points for water leakage. If leakage occurs, it will cause damage to other properties. |   |
| 8. Ensure the correct polarity is maintained throughout all wiring. Otherwise, it will cause electrical shock or fire.  |   |

## 2. Specification

Model			WH-TD20B3E5	WH-TD30B3E5	
Power Supply		Phase, Hz	Single, 50		
		V	230		
Electric Element	Connection	inch	Stainless Steel 5/4 (CW602N brass quality)		
	Material		Incoloy 825		
	Capacity	kW		3	
		Btu/h		10243	
kJ/h			10800		
Pressure vessel	Material		Stainless Steel F18MT / AISI 444 / DIN 1.4521		
	Volume	L	198	287	
Thermostat	Type		1st stage 88 (Cancel by remote control, 2nd stage (Manual cancel)		
	Safety cut off	°C	98		
Thermistor	Set Temperature	°C	40~75		
Heating coil	Material		Stainless Steel LDX 2101 / DIN 1.4162 (Lean Duplex)		
	Diameter / Thickness	mm	Ø 22 / 0.8		
	Surface area	m <sup>2</sup>	0.8		
Insulation	Material		ECO Foam - PUR		
	Thickness	mm	40		
	Heat loss		Approx. 2.1 / 24hours		
Insulation Jacket	Material		Epoxy-coated steel - 90 gloss - white		
Dimension	Diameter	mm	580	580	
	Height	mm	1150	1600	
Weight	Net	kg	45	59	
Connection	Cold water inlet	inch	3/4 (inside baffle plate)		
	Hot water outlet	inch	3/4 (CW602N brass quality)		
	Drain	inch	3/4 (same connection as cold water inlet)		
	Flow & return	inch	2 x 3/4		
	Sensor pocket	inch	2 x 1/2		
	Anode	inch	3/4 (CW602N brass quality in connection)		
Design data	Design pressure	bar	10		
	Design temperature	°C	99		

### 3. Features

- **A hot water storage tank with capacity of 300Litres and 200Litres**
- **High Efficiency**
- **High Durable**
  - Made of clean stainless steel, the tank is designed to provide long lasting durability and toughness and exceptional resistance to rust.
- **Maximum convenience and safety**
  - Hot water setting temperature of tank : 40°C ~ Max 75°C.  
(Set by remote control of indoor unit)
- **Safety by 2 thermostats**
  - 1<sup>st</sup> stage Set 88°C (Can be cancelled by remote control)
  - 2<sup>nd</sup> stage Set 95°C (Can be cancelled by thermostat reset button)
- **Maximum compatibility**
  - Built-in coil in stainless steel which is designed for circulation from solar panel, etc.
- **Serviceability Feature**
  - Easy draining of the heater with a drain valve on the pressure relief valve.

## 4. Location

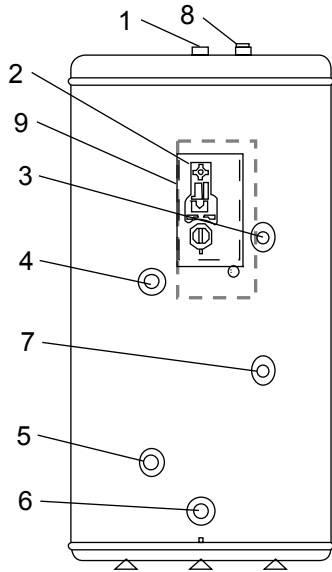

### Main components

1. Hot water outlet (3/4" BSP)
2. Electrical box
3. Sensor pocket (1/2" BSP)
4. Flow inlet (3/4" BSP)
5. Return outlet (3/4" BSP)
6. Cold water inlet (3/4" BSP)
7. Threaded Sensor hole for solar station connection. (1/2" BSP)
8. Anode connector (3/4" BSP)

### 2. Electrical box detail

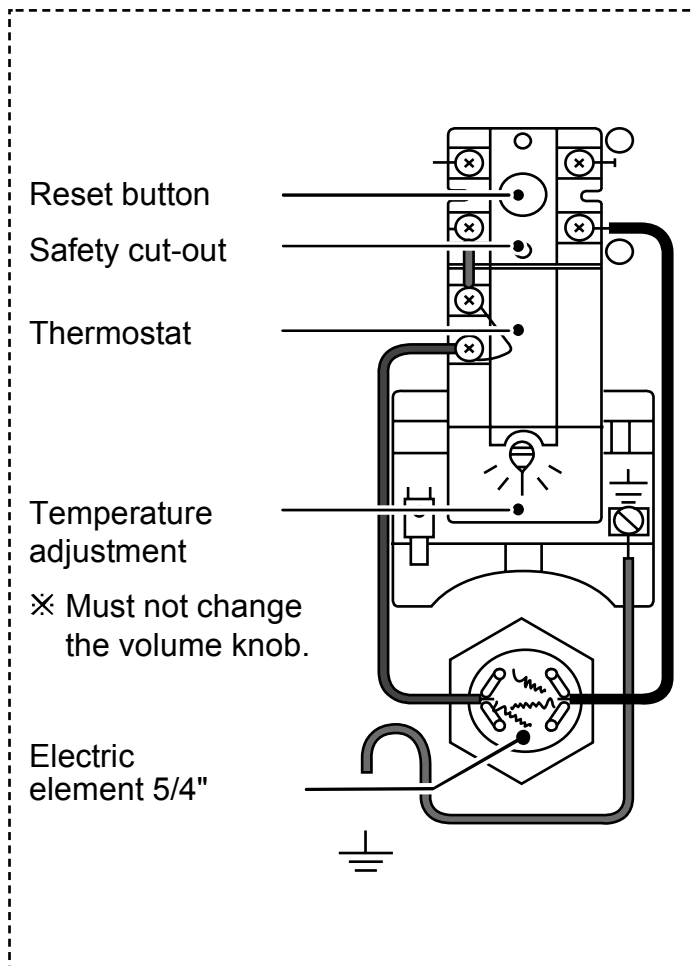

## 5. Dimensions

### 5.1 WH-TD20B3E3

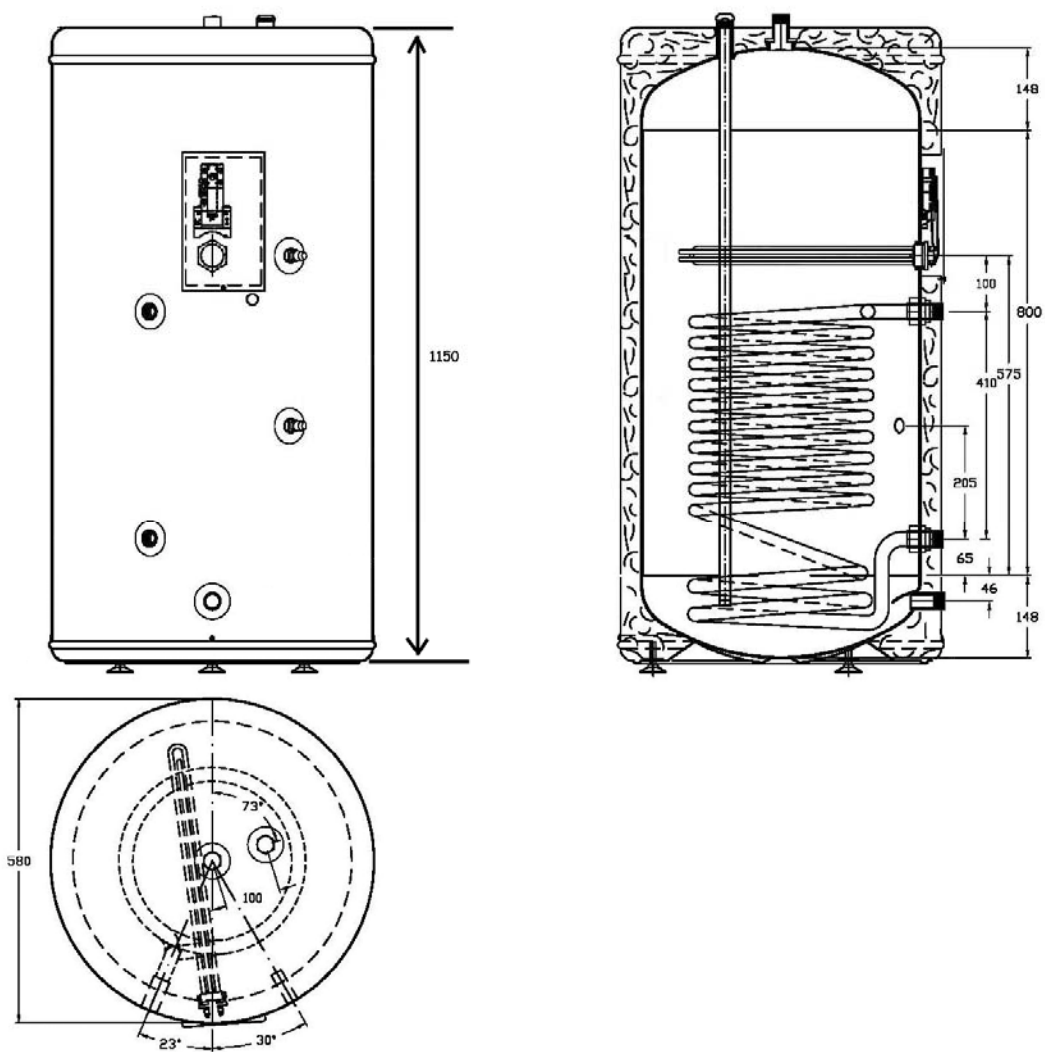

Unit: mm

## 5.2 WH-TD30B3E5

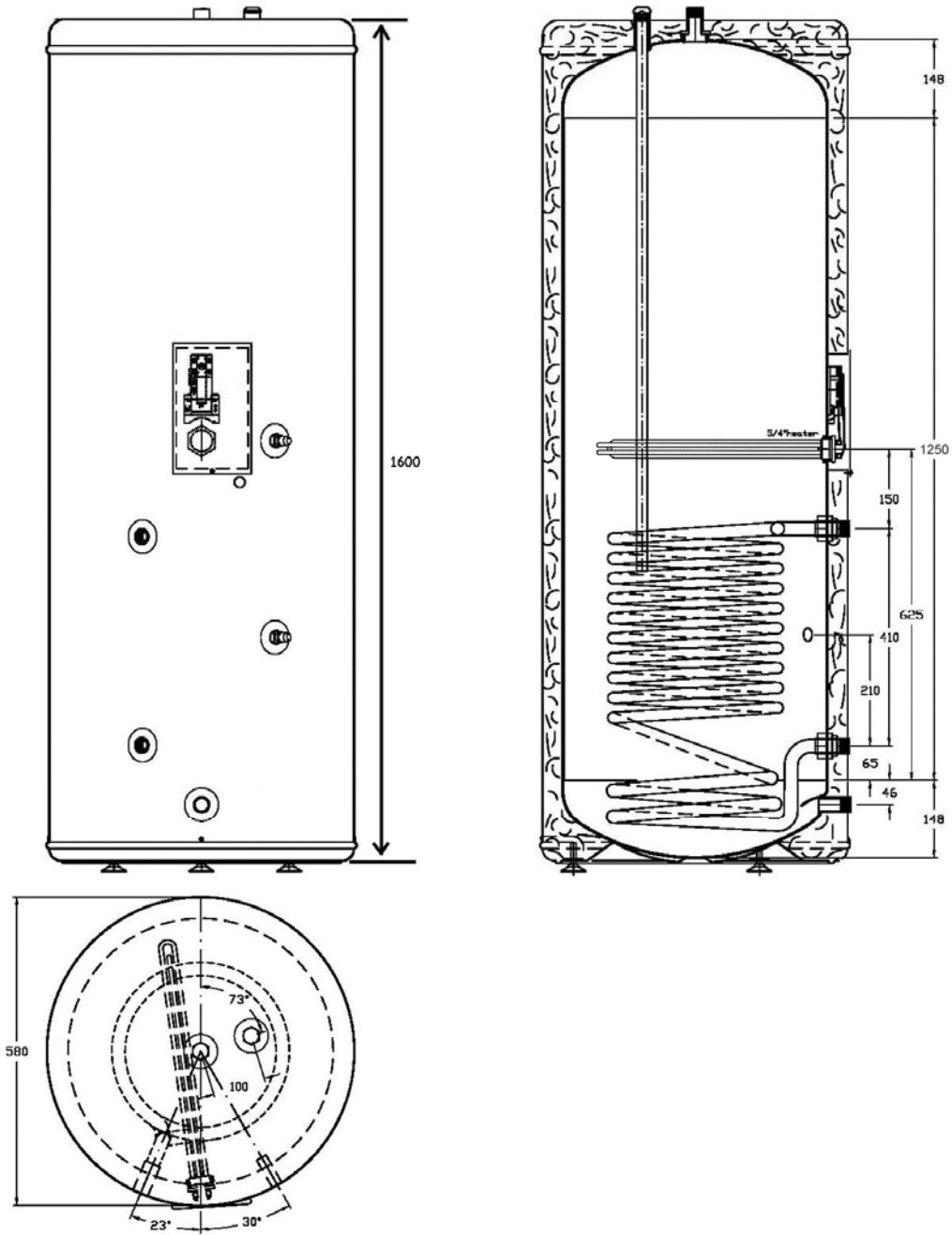

Unit: mm



## 6. Water Cycle Diagram

- Connection for WH-SDH series or equivalent.

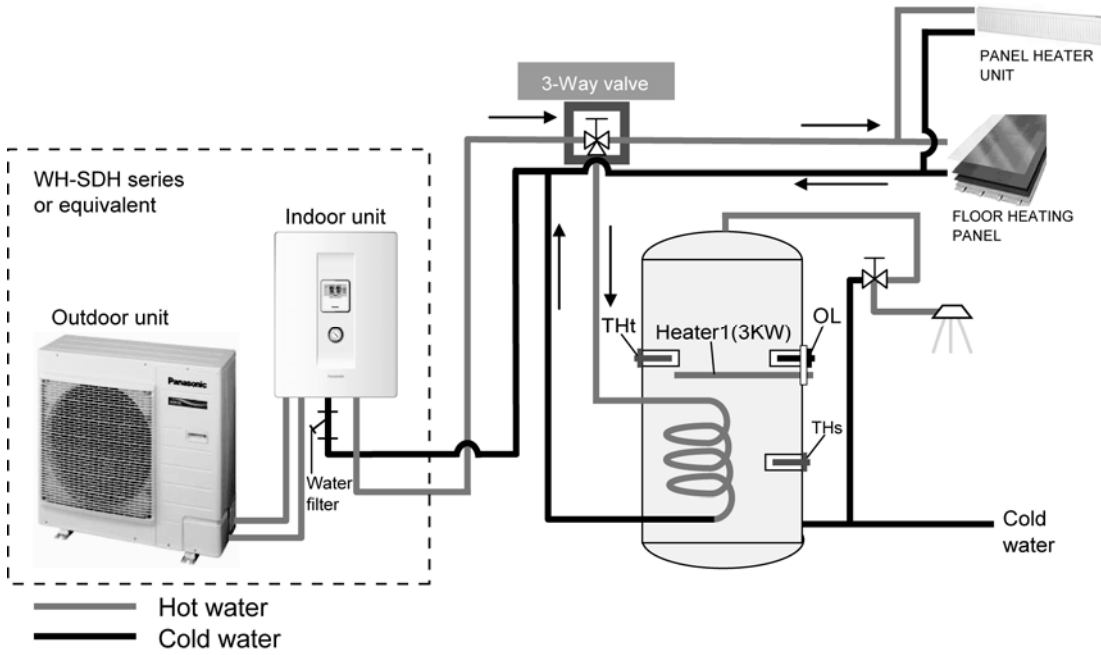

- Connection for WH-SDF / SDC series or equivalent.

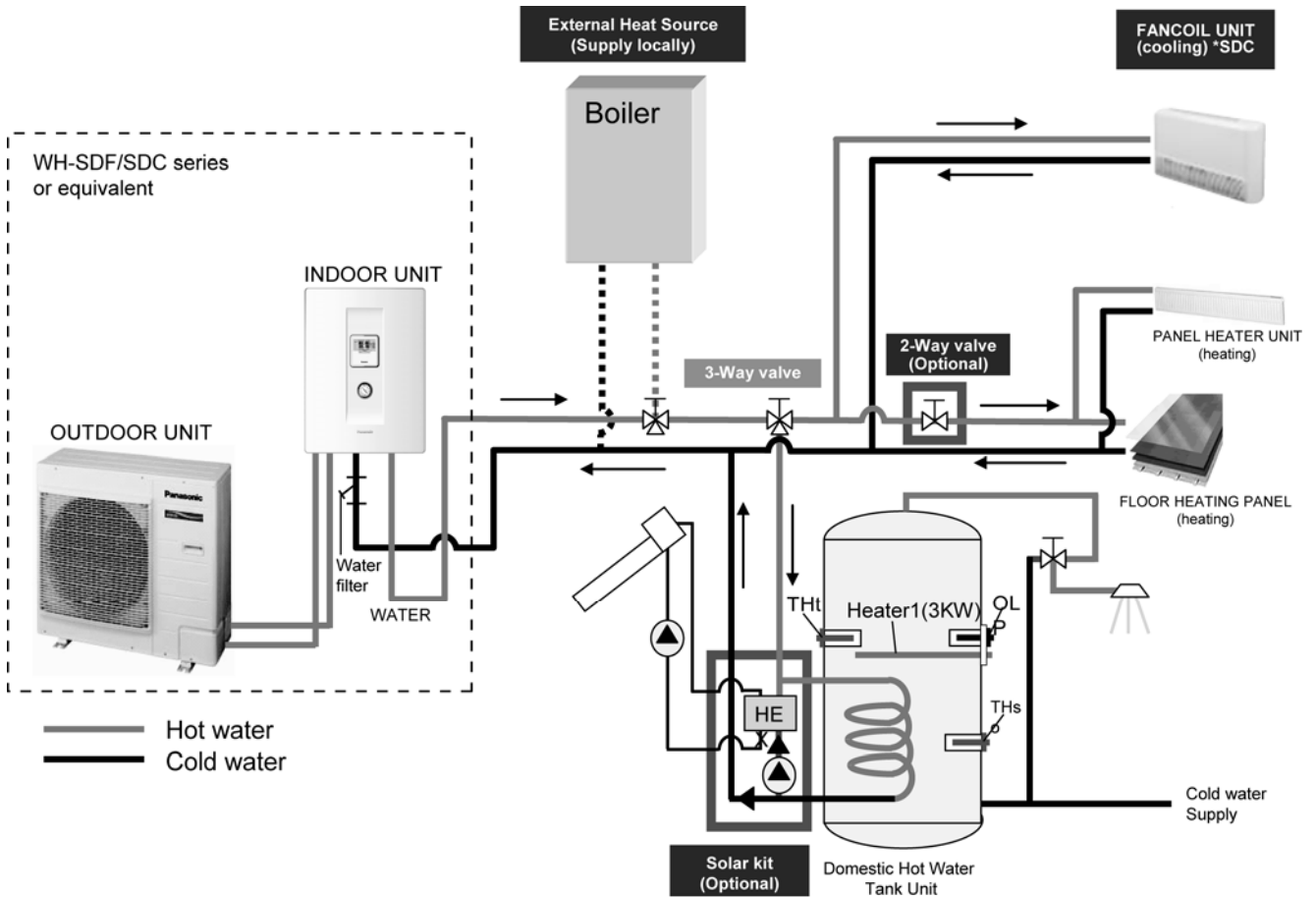

## 7. Installation Instruction

Model	Capacity (Litre)	Dimension (mm)	
		Height	Diameter
WH-TD20B3E5	198	1150	580
WH-TD30B3E5	287	1600	580

### Main components

1. Hot water outlet – 19.05 mm (3/4"BSP)
2. Electrical box
3. Sensor socket – 12.70 mm (1/2"BSP)
4. Flow inlet – 19.05 mm (3/4"BSP)
5. Return outlet – 19.05 mm (3/4"BSP)
6. Cold water inlet – 19.05 mm (3/4"BSP)
7. Threaded Sensor hole for solar station connection – 12.70 mm (1/2"BSP)
8. Anode connector – 19.05 mm (3/4"BSP)

### Accessory parts

- A. 3-way valve
- B. Sensor
- C. Installation manual
- D. Safety valve
- E. Adjustable legs X 3
- F. Anode bar

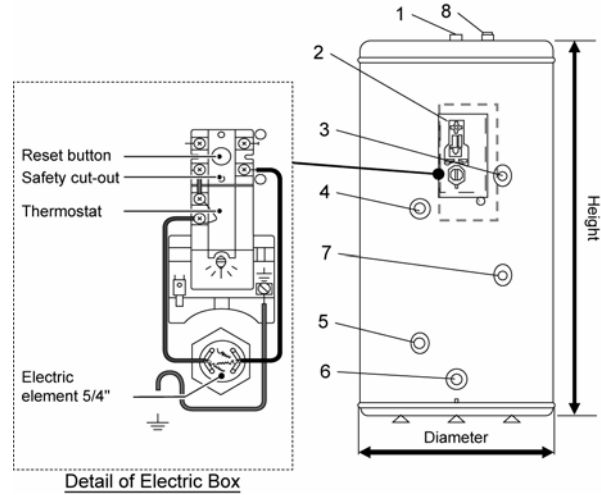

### 7.1 Piping and Wiring Installation

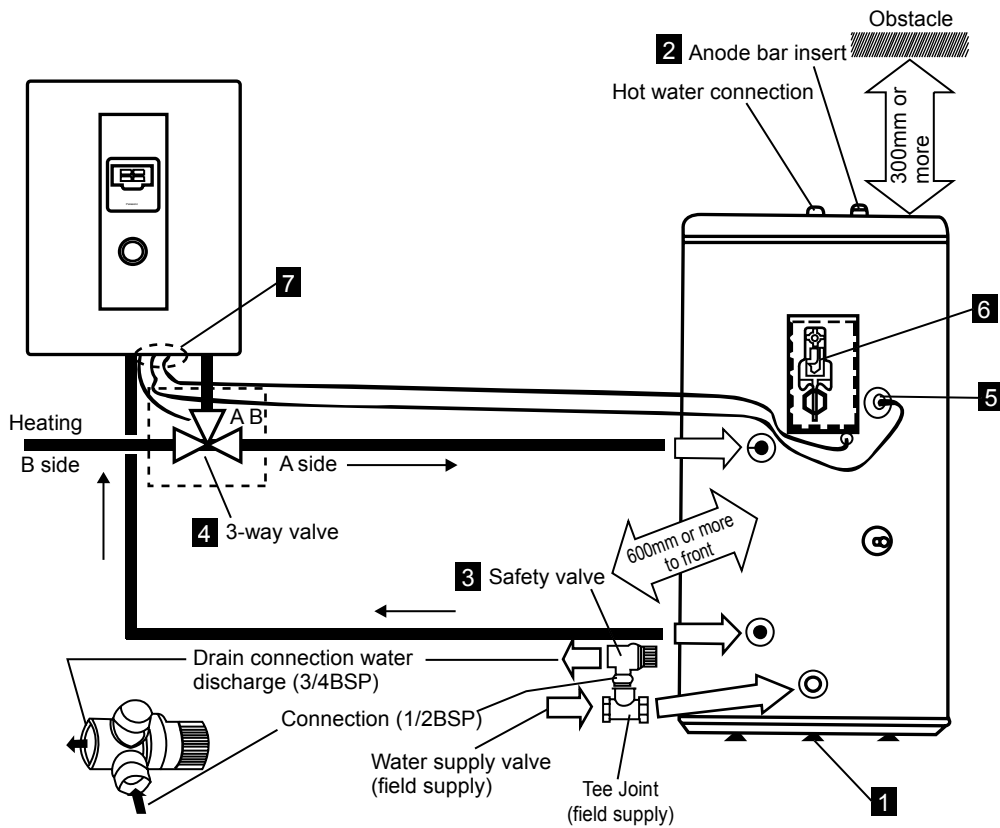

**WARNING**

This section is for authorized and licensed electrician / water system installer only.

Be sure to switch off all power supply (Tank Unit power supply, indoor unit power supply, heater power supply etc.) before performing installation.

- 1** Install adjustable legs at bottom of tank (3 locations) then adjust the height until the unit stable.
- 2** Fix the anode bar into socket.
- 3** Install safety valve at water supply inlet, install drain appropriately.
- 4** Install 3-way valve at outlet tube of indoor unit, connect heating tube connection with tank pipe.

**WARNING**

Be careful on 3-way valve connecting direction.

- "Default" condition is at Heating Side
- "On" condition is at Tank Unit

- 5** Insert sensor until it touches securely end of socket, tighten the cap of socket so that it is not shifted. (Refer bottom diagram)

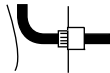

- 6** Connect the cable between heater and OLP, which located inside electrical box as shown at below section. (Wiring at Tank Unit – (Electrical Box) and Wiring at Indoor Unit)

**WARNING**

Use cap tire cable (2 mm<sup>2</sup>) for wiring.  
For SDH series, 3 cables are needed.  
While, for other models, 5 cables is needed.

Fix the cables to the cord protector mountings with cable ties to ensure strain relief closely.

- 7** Insert the cables of 3-way valve, sensor & heater from bushing at the bottom of indoor unit. Guide the wire inside the indoor unit with refer to the installation instruction of indoor unit.  
※ Please keep the space for maintenance purpose (Top: above 300mm / Front: above 600mm)

## 7.1.1 Wiring at Tank Unit (Electrical box)

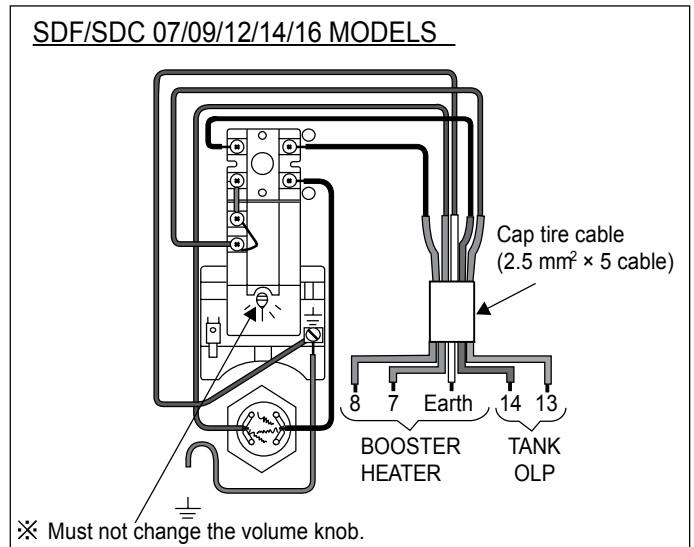
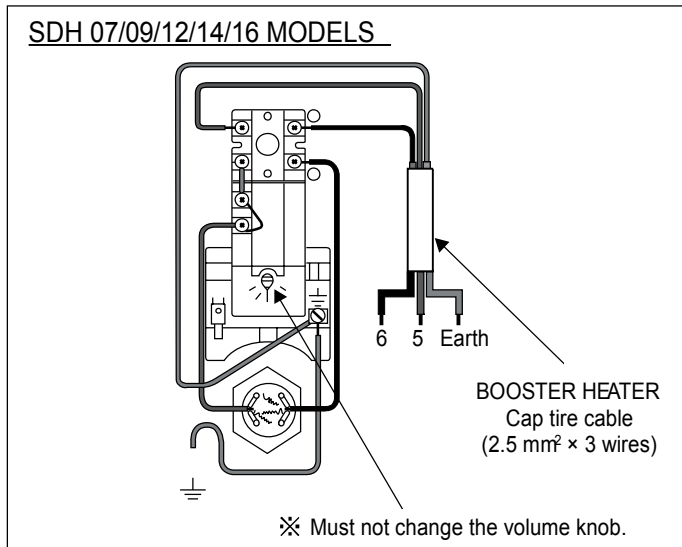

## 7.1.2 Wiring at Indoor Unit

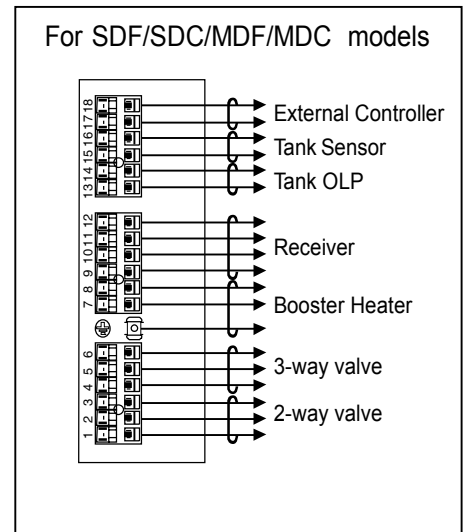
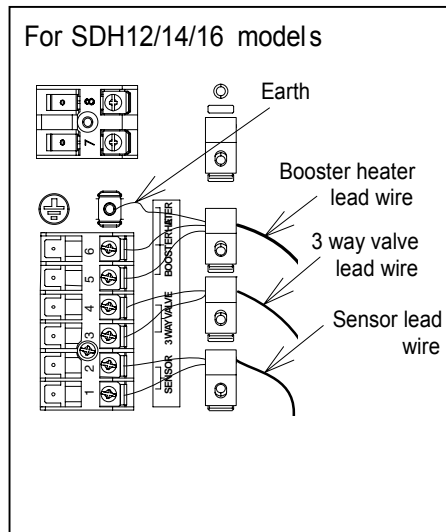
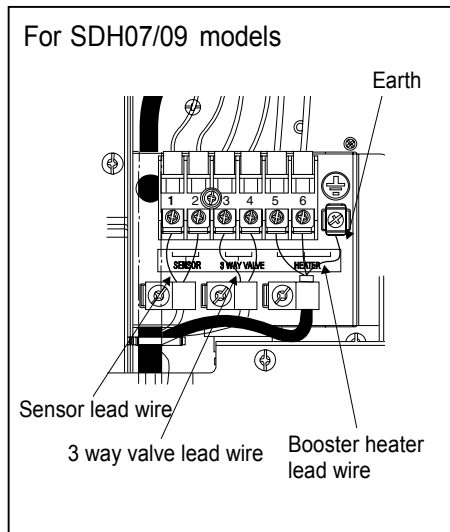

## 7.2 Charge the Water



### WARNING

Make sure Tank Unit filled up with water before switch on the power.

- 1) Make sure all the piping installations are properly done.
- 2) Set the water supply valve "OPEN" and all hot water tap "OPEN".
- 3) Start filling water to the Tank Unit. After 20~40min, water should flow out from hot water tap.  
Else, please contact your local authorized dealer.
- 4) Switch ON the power supply of the Indoor unit. Then set the indoor control panel to "Tank Connection" to "Yes".  
After that, change operation mode to "Tank Mode". Make sure water pump running.  
Else, please contact your local authorized dealer.
- 5) Check and make sure no water leaking at the tube connecting points.

## 7.3 Examine the Anode once a year

To protect the pressure vessel an anode is placed inside the tank. The anode will, depending on the water quality, corrode. When diameter is approx. 8mm the anode must be replaced.

It is easy to check and replace the anode

- 1) Turn off power supply.
- 2) Close water supply valve.
- 3) Manually open the safety valve and drain approx. 2ltrs..
- 4) Unscrew the anode, check and if necessary replace.

## 7.4 Discharge of Water

- 1) Turn off power supply.
- 2) Close water supply valve.
- 3) Open safety valve, by turning knob counter-clockwise until it stays open.
- 4) After discharge, close valve continue turning counter-clockwise until the valve snaps shut.

## 7.5 Precaution on Usage

- When using hot water, it must be mixed with water.  
Please check the hot water's temperature before using it.  
(Hot water may cause scalding.)
- The water quality shall be in accordance with European Council Directive 98/83 EC, or revised version at the date of installation, and is not fed with water from a private supply.  
Particular: Chloride content: Max. 250 mg/l  
Sulphate content: Max. 250 mg/l  
Combination Chloride/sulphate: Max. 300 mg/l (in total)

## 8. Operation Control

### 8.1 Safety Valve

- Use commercial T-joint to joint connection (D) of safety valve. Please install between water supply inlet and water supply tube at below of front side of main unit.
- Please connect discharge drain at connector (R). During boiling, when pressure is above 9bar, expanded water will come out and it is not abnormality.
- Close the water supply main tap, open faucet and turn the safety valve knob K to clockwise direction until stopped at open position, and hot water from tank can be discharged.
- When safety valve is not installed, tank may be damage. It must be installed

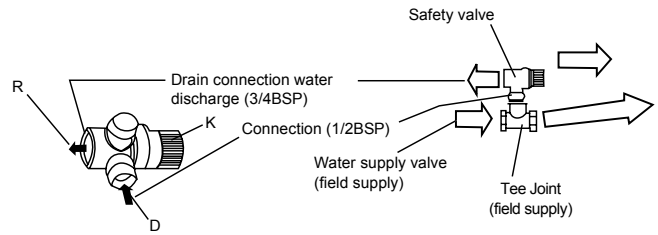

### 8.2 Thermostat

- 1<sup>st</sup> stage Set 88°C (Can be cancelled by remote control) Must not change the volume knob.
- 2<sup>nd</sup> stage Set 95°C (Can be cancelled by thermostat reset button).
- Reset button located on upper part of the thermostat, this button will release and cut all power to the heating element if the internal temperature in the water heater rises above 98°C. If this occurs, the function of the thermostat must be checked by authorized personnel before the reset button is pressed.

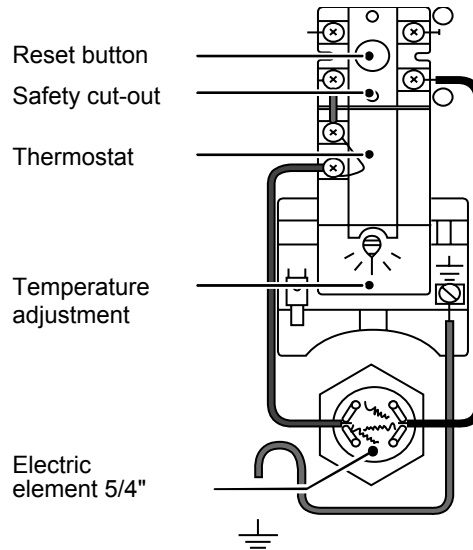

### 8.3 3-Way Valve

- The purpose of 3-way valve is to change the hot water flow to heating panel or to water tank.
- Control content
  - During 3-way valve OFF, the hot water will supply to heating panel.
  - During 3-way valve ON, the hot water will supply to water tank.
  - During OFF condition, the 3-way valve will be switch to OFF position.

## 9. Troubleshooting Guide

Type of failure	Possible cause	Diagnostic and what to do
No hot water	No power supply to the water Heater.	Check if there is any power on the power supply terminal on the thermostat.
	The fuse or safety cut-off to operate.	Press the reset button.
No heating	Heating element or internal electrical wiring out of order.	Check if there is any power on the power supply on the connector of the heating element. If this OK, press the reset button on the fuse/safety cut-off.
Water not warm enough	Heating element or the internal electrical wiring partially out of order.	Adjust the thermostat up using a std. screwdriver.
		Check the resistance of the heating element on the connector of the heater bundle, and the condition of the internal wiring.
Safety valve (SV) is dripping	Water expands when heated. If there is no consumption of hot water over a period of time pressure builds up, causing the safety valve to open.	If drip from the SV is severe it might need to be replaced. Some dripping is normal. Alternatively an expansion vessel can be fitted.
Leak warning outlet is dripping	The heating element may not be properly tightened, or there may be a leak.	Check the heating element o-ring seal and all connections.

## 10. Disassembly Instructions

### 10.1 Replacing the Heating Element

1. Disconnect the power cable.
2. Remove the electric box lid (1).
3. Open Safety Relief valve (2) for a few seconds to relieve some of the pressure. This is done by turning knob counter-clockwise. Close the valve by turning the knob fully counter-clockwise until snaps shut.
4. Disconnect all wires from the element.
5. Remove the element (3) by using an element socket tool. Some water will flow from the element connection when removing it.
6. Quickly clean the O-ring slot. Enter the new heating element (3), with a new O-ring fitted, into its connection. **Important:** Make sure the element enters the thread correctly and that the O-ring is placed in its correct position. Tighten element.
7. Refit the wires to the element in their correct positions, tighten property.
8. Refit the electric box lid and reconnect the power cable.

Fig. A

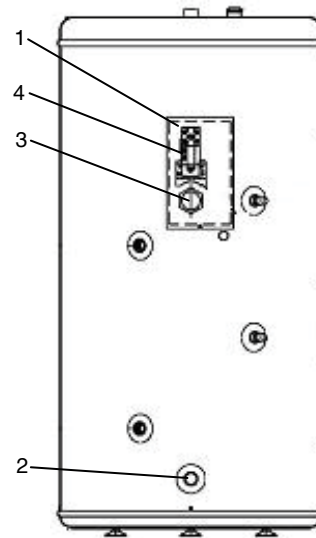

### 10.2 Replacing the Thermostat

1. Disconnect the power cable.
2. Remove the lid (1) covering the electric box.
3. Loosen screws (see fig. B) and disconnect the electric wires.
4. Remove thermostat (4) by pulling back slightly on steel clip S using two fingers, then lifting the thermostat slightly horizontally out of the electrical box.
5. Replace thermostat by again pulling back on steel clip S before slotting the new thermostat into place.
6. Reconnect the wires to connections (see fig. B), tighten property.

Fig. B

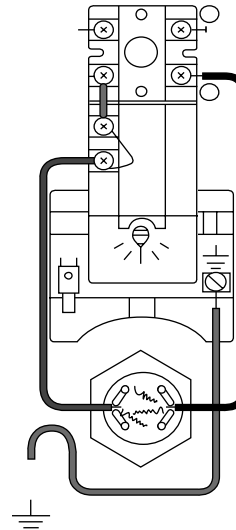

**Important:** Refit the electric box lid before reconnecting the power cable.

**Note:** All reference numbers relates fig. A above.

### 10.3 Replacing the Sacrificial Anode

1. Inspect anode annually.
2. Cut the water supply at hot water outlet (1).
3. Open Safety Relief valve (3) for a few seconds to relieve some of the pressure by turning knob (K) counter-clockwise until it snaps shut.
4. Pull the anode 2/3 out of the tank for inspection. Minimum diameter of anode is 8mm. If the anode measures less than 8 mm in diameter in any area, it must be replaced.
5. Reinstall/replace the anode and tighten properly. Ensure the anode enters the threads correctly and that its O-ring seal is in place.
6. Resume water supply at hot water outlet (1).

Fig. C

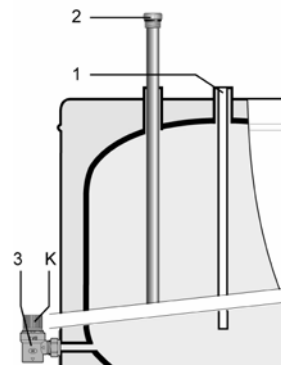



# 11. Technical Data

## 11.1 Tank Thermistor

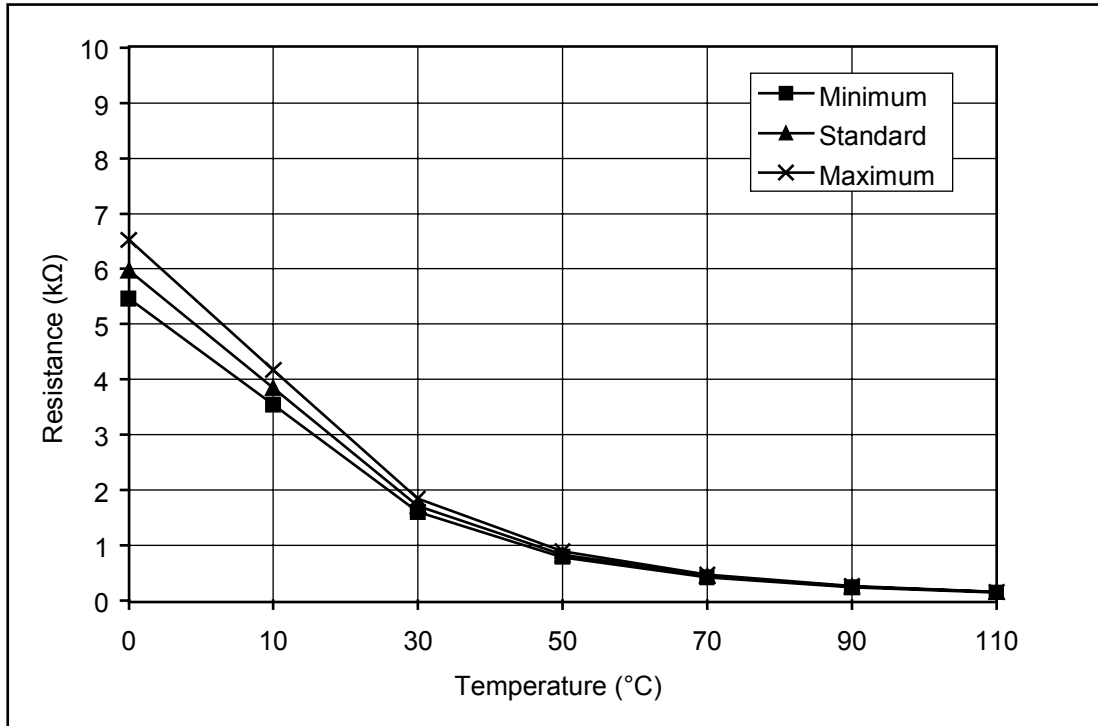

## 12. Replacement Parts List

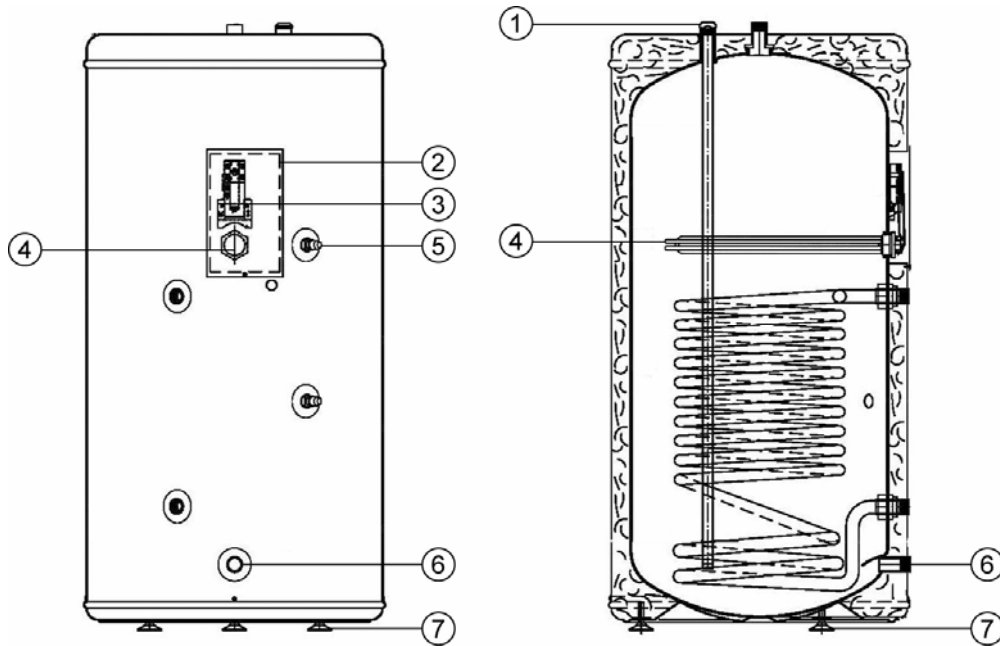

REF. NO.	PART NAME & DESCRIPTION	QTY	WH-TD20B3E5	WH-TD30B3E5	REMARK
1	ANODE	1	56200	56250	
2	ELECTRIC BOX LID	1	74000	←	
3	THERMOSTAT KIT	1	80060	←	
4	5/4" HEATING ELEMENT 1 x 240V	1	71259	←	
5	THERMISTOR POCKET	1	81020	←	
6	SAFETY RELIEF VALVE SV-2	1	90405	←	
7	ADJUSTABLE FEET	3	60710	←	
8	THERMISTOR SENSOR	1	81809	←	
9	3-WAY VALVE	1	90250	←	
10	ACTUATOR FOR VALVE	1	90252	←	

(Note)

- The non numbered parts are not kept as standard service parts.
- All parts are supplied from PHAAE, Germany.