

Service Manual

AIR CONDITIONER

CS-W50BTP CU-V50BBP8
CS-W50BTP CU-W50BBP8



⚠ WARNING

This service information is designed for experienced repair technicians only and is not designed for use by the general public. It does not contain warnings or cautions to advise non-technical individuals of potential dangers in attempting to service a product. Products powered by electricity should be serviced or repaired only by experienced professional technicians. Any attempt to service or repair the product or products dealt with in this service information by anyone else could result in serious injury or death.

⚠ PRECAUTION OF LOW TEMPERATURE

In order to avoid frostbite, be assured of no refrigerant leakage during the installation or repairing of refrigeration circuit.

CONTENTS

	Page		Page
1 SERVICE INFORMATION	3	13 SAFETY DEVICE	33
2 FEATURES	4	14 COMPONENT SPECIFICATION	34
3 SPECIFICATION (HEAT PUMP TYPE)	9	15 CAPACITY AND POWER CONSUMPTION	35
4 SPECIFICATION (COOLING ONLY TYPE)	10	16 DISCHARGE AND SUCTION PRESSURE	38
5 TECHNICAL DRAWING	11	17 REACHING DISTANCE	39
6 CIRCUIT DIAGRAM	13	18 SOUND DATA	40
7 OPERATING INSTRUCTION	25	19 TWIN AND TRIPLE	42
8 REFRIGERATION CYCLE	27	20 WIRING MISTAKE PREVENTION	47
9 OPERATION RANGE	28	21 TEST OPERATION AND SELF DIAGNOSIS	48
10 PIPE LENGTH	29	22 SETTING OF SAVE ENERGY AND THERMISTOR SWITCH ...	52
11 OPERATING CHARACTERISTIC	31	23 GROUP CONTROL	53
12 FAN PERFORMANCE	32	24 TROUBLESHOOTING	54

Panasonic

© 2002 Matsushita Industrial Corporation. Sdn. Bhd. (11969-T). All rights reserved. Unauthorized copying and distribution is a violation of law.

25 EMERGENCY OPERATION	59	29 INSTALLATION (INDOOR UNIT)	82
26 CONTROL	60	30 INSTALLATION (OUTDOOR UNIT)	92
27 WIRED REMOTE CONTROL INSTALLATION MANUAL	70	31 REPLACEMENT PARTS	104
28 WIRELESS REMOTE CONTROL INSTALLATION MANUAL ...	75		

1 SERVICE INFORMATION

Caution:

- Pb free solder has a higher melting point than standard solder; Typically the melting point is 50 - 70°F (30 - 40°C) higher. Please use a high temperature soldering iron. In case of the soldering iron with temperature control, please set it to 700 ± 20°F (370 ± 10°C).
- Pb free solder will tend to splash when heated too high (about 1100° F/600°C).

Notice of Address setting for NEW Ceiling / NEW Outdoor Unit.

The new Ceiling / new Outdoor models are possible to have address setting for twin / triple control or group control automatically when main power supply is switched on.

(Manual address setting is also possible by using DSW1 switch on the indoor unit P.C. board.) However, **this address setting is only possible when proper wiring connection is made and indoor unit must be of original unit.**

1.1. Example of trouble during test operation

If the below phenomenon is found during test operation, wrong address setting is possible. Therefore, please inspect the address setting.

1. LCD display of the wired remote control is not illuminated although the main power supply switch is 'on'.
2. LCD display had indicated as normal illumination when power supply switch is 'on', however outdoor unit cannot be operated. (But, it is necessary to take 3 to 5 minutes for outdoor unit to start from the timing of remote control OFF/ON button is 'on'.) (For normal operation, the outdoor unit will only start its operation after 3 to 5 minutes upon pressing the OFF/ON button.)
3. P.C. board had memorized wrong setting information.
 - a. If main power supply is switched on with the wrong connection.
 - b. When changing the connection or combination of units due to re-installation etc.
 - When changing the system from twin to triple (triple to twin).
 - When changing the system from group control to normal one to one system.
 - When making the replacement of units of master and slave etc.

1.2. Caution during test operation

Do not touch the remote control button and do not change any wirings for one minute when the main power supply switch is 'on'. (Because the unit is having automatic address setting during the first one minute.)

1.3. Caution during automatic address setting

When the main power supply switch is 'on', the P.C. board will automatically memorize the connecting system. Consequently, when initial power supply is 'on', there mustn't be any interchanging of units even of the same type and same capacity unit.

Therefore, connection of the unit to another system is prohibited.

2 FEATURES

2.1. New design

2.1.1. Gentle curved styling

- The base has gentle curves which express a functional beauty. It spreads the air quietly over a wide area.

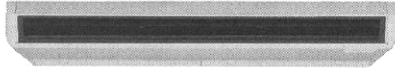

Front view

2.2. Such quietness!

2.2.1. Several new mechanism add up to low 49 dB noise (W50BT - High Fan Speed)

1. Delta throat fan

A delta throat (projection) has been attached to the fan outlet to suppress the generation of vortices. This helps maintain air flow speed even at lower fan speeds and is effective in reducing noise.

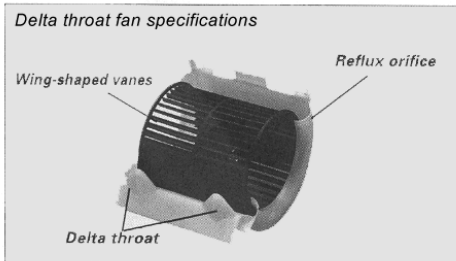

2. Reflux orifice

The orifice at the intake port is equipped with an air flow guide which minimizes the flow disturbances which occur at the orifice and inside the impeller.

This reduces pressure losses inside the casing and also helps reduce noise.

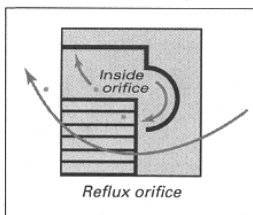

3. Adoption of wing-shaped vanes

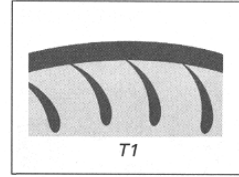

- The vanes of the fan have been changed to “aerodynamic” shaped vanes, so that the air flow more smoothly over the vane surfaces and noise is thus suppressed.
- Side filters have been adopted in the pipe partitions. These allow the air intake space to be increased and also further reduce noise.

2.2.2. Automatic swinging louvre

- The horizontal air flow angle is a wide 100 degrees (manual). The louvre can swing automatically (through 70 degrees vertically) using the remote control. This increases the area of comfortable air flow and warms the air even to floor level.

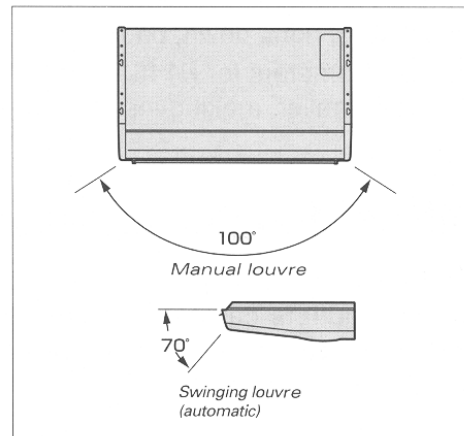

2.2.3. Newly-shaped louvre

- The newly-shaped louvre and air outlet effectively distribute the air flow. During cooling, this stops warm air from collecting near the louvre, and prevents freezing.

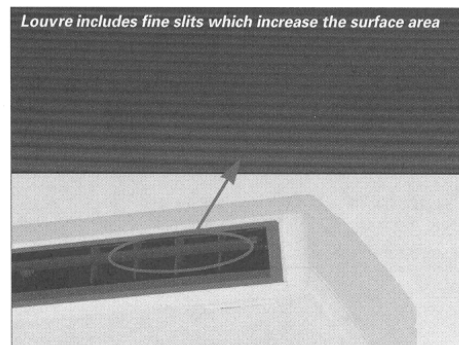

2.3. Easy installation

2.3.1. Easy suspension

- A suspension bolt fixing bracket with 4-point support is attached to the main unit, which increases the space available for installation.

2.3.2. Two installation methods : standard and wall

- In addition to the standard (1) ceiling installation, a wall (2) installation method (using a wall-hanging bracket) is available for cases where the ceiling is too high for the main unit to be suspended.

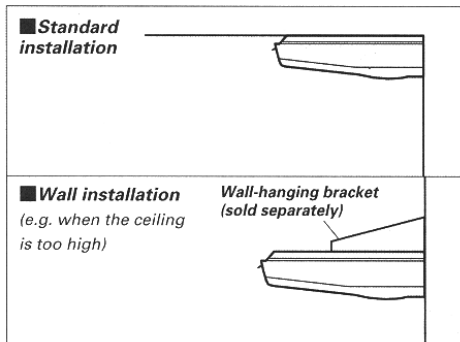

2.4. Piping

2.4.1. 3-direction pipe lead-out

- The refrigerant piping can lead out in one of three directions (right, rear-right and top-right), and the drain pipe direction can be selected from four directions (right, rear-right, left and rear-left).

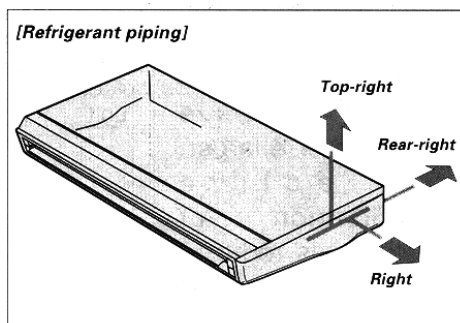

2.5. Easy maintenance

2.5.1. Long life filter (standard equipment)

- In general office environments, cleaning (maintenance) is not required until after approximately 2,500 hours of operation, thus reducing maintenance work.
- For optimum comfort, it is recommended to clean the air filter every 1-1/2 months.

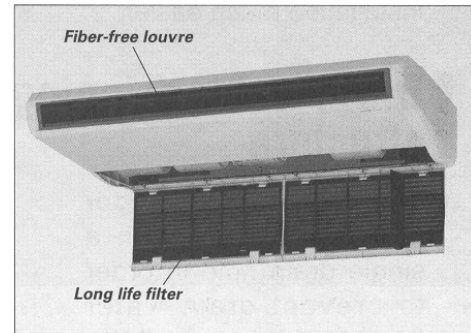

2.5.2. Maintenance is possible from underneath the unit.

- If the bottom panel is detached, the drain pan can then be removed and installed from underneath the unit, and inspection and servicing of component such as the control panel also becomes easier.

2.6. Auto fan mode (indoor unit)

- Auto fan mode is added besides high, medium and low. It automatically adjusts the fan speed according to the indoor unit's temperature.

2.7. Hot start system (heat pump models)

2.8. Automatic changeover function (heat pump models)

- The unit automatically switches between cooling and heating in accordance with operating load in order to maintain a comfortable indoor temperature.

2.9. Low-noise outdoor units

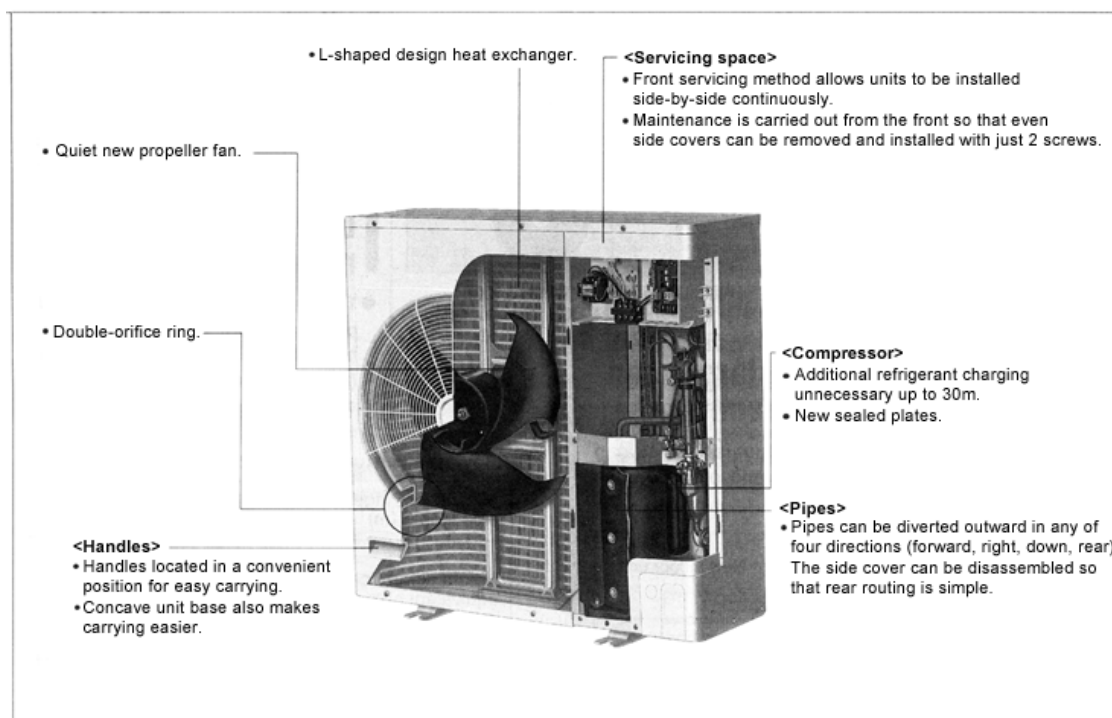

2.9.1. Product features

- **Low-noise design improves comfort in surrounding areas**

1. The noise-suppressing winglet fan is a result of new research into vane design theory. The unique curved shape suppresses the generation of vortices, thus reducing air flow noise.
2. The adoption of double-orifice rings reduces air passage resistance.
3. Strengthening of the noise insulation materials in the compressor and the sealing-in of mechanical noise allows vibration noise to be greatly enclosed and suppressed.
4. The heat exchanger has an L-shaped design to allow air to flow more smoothly.
5. Noise is automatically reduced further during night-time operation with lower outdoor air temperatures.

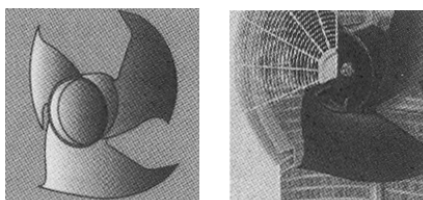

2.10. Greatly improved workability increases system renewal capability

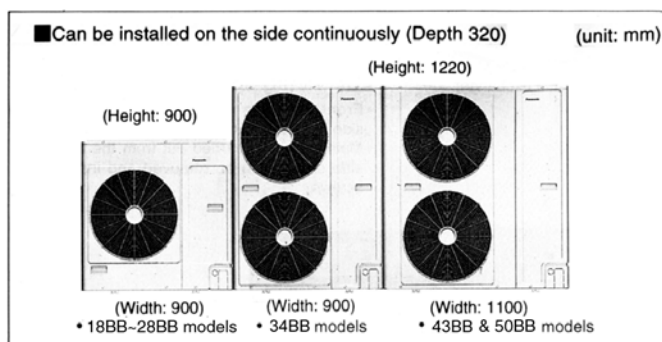

- **Pipes that are one size larger can also be connected for renewal.**

- If renewing the system, existing refrigerant pipes can be utilized so that only the indoor and outdoor units need to be replaced.
- For example, liquid and gas pipes from 10 years ago can be connected to current pipes with the same size or one size larger. Effective utilization of materials reduces working time and trouble. (Adaptor sockets are not supplied.)

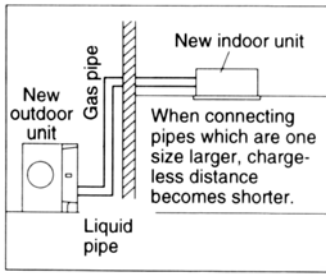

- **Additional refrigerant charging unnecessary for 30 m**
 - All models do not require any additional charging of refrigerant for 30 m of pipe length. This makes installation much easier.
- **Drain water dripping-prevention structure**
 - The base of the outdoor unit is provided with a single drain hole in order to prevent drain water from leaking out of the unit. By connecting a drain elbow and a discharge pipe, water leakages can be prevented even when the unit is installed to a wall.

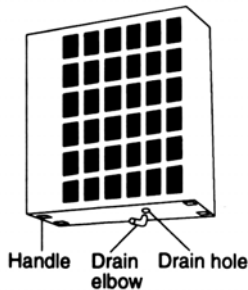

- **Save space design allows units to be installed side-by-side continuously**
 - Servicing after installation can be carried out by removing the front covers.
- **Long pipe design for refrigerant pipes**
 - Maximum piping length of 50m for all models.
- **Internal pipe connection**
 - Pipes are connected inside the units (inside the side covers), making the final appearance more attractive.
 - Pipes can be diverted outward in any of four directions (forward, right, down, rear).
 - Small liquid pipe diameters of 9.52mm for 50BB models, making installation work much easier.
- **Centralized draining method**
 - Even when multiple outdoor units are installed to a wall, the drain outlets can be concentrated into a single drain pipe. This makes installation easier and also improves appearance.

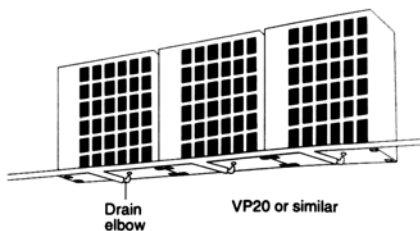

2.11. A brand-new control method using the latest in technology

- **Easier power supply wiring connection**
 - Power supply wiring and other wiring tasks can be carried out more easily.
 - Twin non-polar wires used to connect indoor and outdoor units.
 - Adoption of connection error prevention circuits for drive wires and signal wires. If a connection error is made, the relay does not operate and current does not flow to the circuit boards.

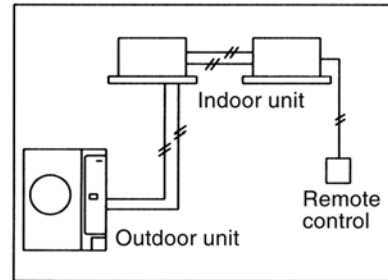

- **Twin and Triple operation**
 - Simultaneous air conditioning of wide spaces and corners is possible. Indoor units of different horsepowers can even be used in combination.
 - Master unit and slave-units can be set automatically in twin and triple systems. No address setting is necessary.
 - Multiple indoor units can be operated simultaneously with a single remote control. Note that individual operation is not possible.
- **Separate indoor/outdoor unit power supplies**
 - The power supply can be connected to (1) just the outdoor units, or (2) to both the indoor and outdoor units.
- **Easy test operation**
 - Test operation can be carried out for both indoor and outdoor units.
- **Automatic setting initialization function (Remote control and Indoor unit)**
 - In accordance with the indoor and outdoor units connected and the connection methods, conditions such as the connection configuration (twin or triple format) and remote-control functions such as automatic louvre operation and cooling or heating mode are automatically detected and set instantly.

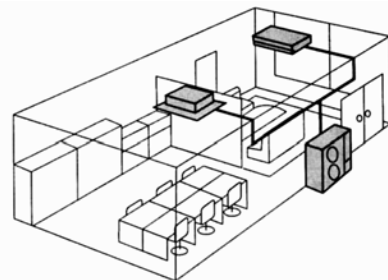

2.12. Wired Remote Control

- The new design includes an easily-visible red pilot lamp. The power can be turned on and off at a single touch, without opening the cover.
- Has a built-in thermistor, allowing indoor temperature detection in accordance with indoor conditions by switching with main unit thermistor.
- Twin non-polar wires make installation work easy. (10 m cable supplied as accessory.)

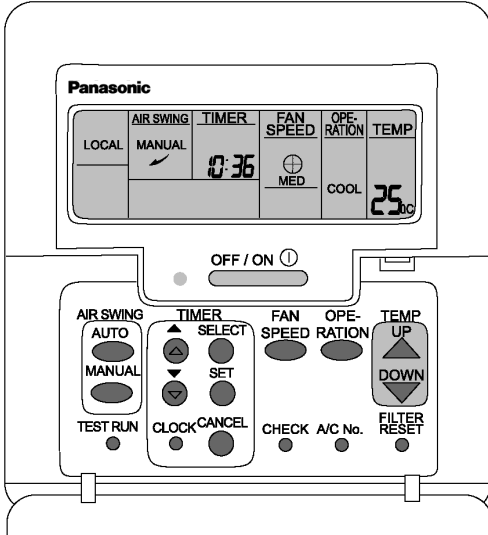

2.13. Wireless Remote Control

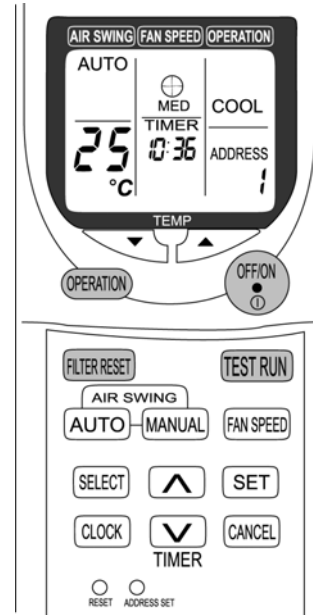

- New design with compact size. (Operation range within approximately 8 m.)
- Built-in timer with ON/OFF timer setting (within 24 hours)

	Wired	Wireless
Heat Pump	CZ-RD51P	CZ-RL51P
Cooling	CZ-RD51P	CZ-RL01P

NOTE: Both of the above remote control is packed separately from the indoor unit.

2.14. Group Control Equipment

Wired remote control	Group control by one remote control <ul style="list-style-type: none"> • All air conditioner units are controlled as a whole by remote control. • All indoor units operate in the same mode. • A maximum of 16 units can be connected together (sequential starting) 	<p>Remote-side remote control</p> <p>Indoor units</p>	[Remote side] <ul style="list-style-type: none"> • Optional wired remote control CZ-RD51P [Local side] Not needed
	Twin remote control separate control <ul style="list-style-type: none"> • Each indoor unit can be operated by either of the two remote control. • Apart from timer setting time, displays for two remote control are identical. • Last button pressed has priority (main or slave is set at remote control unit). 	<p>Remote-side remote control</p> <p>Local-side remote control</p> <p>Indoor units</p>	[Remote side] <ul style="list-style-type: none"> • Optional wired remote control [Local side] <ul style="list-style-type: none"> • Optional wired remote control CZ-RD51P
Common control	Common control / group <ul style="list-style-type: none"> • Operation is possible using either wired or wireless remote control unit. • Last button pressed has priority. 	<p>Receptor unit</p> <p>Wireless remote control</p> <p>Wired remote control</p>	<ul style="list-style-type: none"> • Optional wired remote control and wireless remote control (Wired) CZ-RD51P (Wireless-Cooling only) CZ-RL01P (Wireless-Heat Pump) CZ-RL51P

3 SPECIFICATION (HEAT PUMP TYPE)

CS-W50BTP / CU-W50BBP8

ITEM / MODEL			Indoor Unit		Outdoor unit	
			CS-W50BTP		CU-W50BBP8	
Main Body						
Remote Control			CZ-RD51P (Wired) CZ-RL51P (Wireless)			
Cooling Capacity			kW	14.0		
			BTU/h	47,700		
Heating Capacity			kW	16.0		
			BTU/h	54,600		
Refrigerant Charge-less			m	30		
Standard Air Volume for High Speed			m ³ /min	35		
			cfm	1236		
Outside Dimension (H x W x D)			mm	250 x 1600 x 700	1220 x 1100 x 320	
			inch	9-27/32 x 62-31/32 x 27-9/16	48-1/24 x 43-5/16 x 12-19/32	
Net Weight			kg	47	115	
			lbs	104	254	
Piping Connection	Refrigerant	Gas	mm (inch)	O.D Ø 19.05 (3/4) Flared Type		
		Liquid	mm (inch)	O.D Ø 9.52 (3/8) Flared Type		
	Drain	mm	O.D Ø 20		I.D Ø 20 x 1	
Compressor	Type, Number of Set			-	Hermetic-1 (Scroll), 1	
	Starting Method			-	Direct on-line starting	
	Motor	Type		-	2-pole 3-phase induction motor	
		Rated Output	kW	-	4.10	
Fan	Type, Number of Set			Sirocco fan		Propeller fan
	Motor	Type		4-pole single phase induction motor	6-pole single phase induction motor	
		Rated Output	kW	0.14	0.055 x 2	
Air-heat Exchanger				Slit-fin type	X-Louvre-fin type	
Refrigerant Control			Cool	Capillary tube		
			Heat	-		
Refrigerant Oil (Charged)			litre	-		
Refrigerant (Charged)			kg	-		
			(oz)	R407C (4.4) (155)		
Running Adjustment	Control Switch			Wireless or Wired Remote Control		
	Room Temperature			Thermostat (Main Body)		
Safety Devices				Internal protector for compressor, Internal thermostat for fan motor, Crankcase heater, High and heating pressure switch, Current transformer		
Noise Level			dB (A)	Hi 49 Lo 45		Cooling 56, Heating 58
			Power level dB	Cooling : Hi 66 Lo 62 Heating : Hi 66 Lo 62		Cooling 69, Heating 71

1. Cooling capacities are based on indoor temperature of 27°C D.B. (80.6°F D.B.), 19.0°C W.B. (66.2°F W.B.) and outdoor air temperature of 35°C D.B. (95°F D.B.), 24°C W.B. (75.2°F W.B.)
2. Heating capacities are based on indoor temperature of 20°C D.B. (68°F D.B.) and outdoor air temperature of 7°C D.B. (44.6°F D.B.), 6°C W.B. (42.8°F W.B.)

ELECTRICAL DATA (50Hz)

ITEM / MODEL			CS-W50BTP, CU-W50BBP8		
			Condition by JIS B 8615		
Volts	V		380	400	415
Phase			3N	3N	3N
Power Consumption	kW	Cool	5.35	5.35	5.35
		Heat	5.45	5.45	5.45
Running Current	A	Cool	9.2	9.2	9.2
		Heat	9.2	9.2	9.2
Starting Current	A		69	69	69
Power Factor	%	Cool	88	84	81
		Heat	90	86	82
*Power Factor means total figure of compressor, indoor fan motor and outdoor fan motor.					
Panasonic	Power source		AC, 3N-380V, 400V, 415V 50Hz		

4 SPECIFICATION (COOLING ONLY TYPE)

CS-W50BTP / CU-V50BBP8

ITEM / MODEL			Indoor Unit		Outdoor unit	
			Main Body	CS-W50BTP	CU-V50BBP8	
Cooling Capacity			kW	14.0		
			BTU/h	47,700		
Refrigerant Charge-less			m	30		
Standard Air Volume for High Speed			m ³ /min	35		
			cfm	1236		
Outside Dimension (H x W x D)			mm	250 x 1600 x 700	1220 x 1100 x 320	
			inch	9-27/32 x 62-31/32 x 27-9/16	48-1/24 x 43-5/16 x 12-19/32	
Net Weight			kg	47	112	
			lbs	104	247	
Piping Connection	Refrigerant	Gas	mm (inch)	O.D Ø 19.05 (3/4) Flared Type		
		Liquid	mm (inch)	O.D Ø 9.52 (3/8) Flared Type		
	Drain		mm	O.D Ø 20	I.D Ø 20 x 1	
Compressor	Type, Number of Set			-	Hermetic-1 (Scroll), 1	
	Starting Method			-	Direct on-line starting	
	Motor	Type		-	2-pole 3-phase induction motor	
Rated Output		kW		-	4.10	
Fan	Type, Number of Set			Sirocco fan	Propeller fan	
	Motor	Type		4-pole single phase induction motor	6-pole single phase induction motor	
		Rated Output	kW		0.14	0.055 x 2
Air-heat Exchanger				Slit-fin type	X-Louvre-fin type	
Refrigerant Control				Capillary tube	Capillary tube	
Refrigerant Oil (Charged)			litre	-	MMMAPOE	
Refrigerant (Charged)			kg	-	R407C (4.4)	
			(oz)		(155)	
Running Adjustment	Control Switch			Wireless or Wired Remote Control		-
	Room Temperature			Thermostat (Main Body)		-
Safety Devices				Internal protector for compressor, Internal thermostat for fan motor, Crankcase heater, High pressure switch, Current transformer		
Noise Level			dB (A)	Hi 49 Lo 45	56	
			Power level dB	Hi 66 Lo 62	69	

1. Cooling capacities are based on indoor temperature of 27°C D.B. (80.6°F D.B.), 19.0°C W.B. (66.2°F W.B.) and outdoor air temperature of 35°C D.B. (95°F D.B.), 24°C W.B. (75.2°F W.B.)

ELECTRICAL DATA (50Hz)

ITEM / MODEL			CS-W50BTP, CU-V50BBP8		
			Condition by JIS B 8615		
Volts	V		380	400	415
Phase			3N	3N	3N
Power Consumption	kW	Cool	5.35	5.35	5.35
Running Current	A	Cool	9.2	9.2	9.2
Starting Current	A		69	69	69
Power Factor	%	Cool	88	84	81
*Power Factor means total figure of compressor, indoor fan motor and outdoor fan motor.					
Panasonic	Power source		AC, 3N-380V, 400V, 415V 50Hz		

5 TECHNICAL DRAWING

CS-W50BTP
OUTSIDE DIMENSION

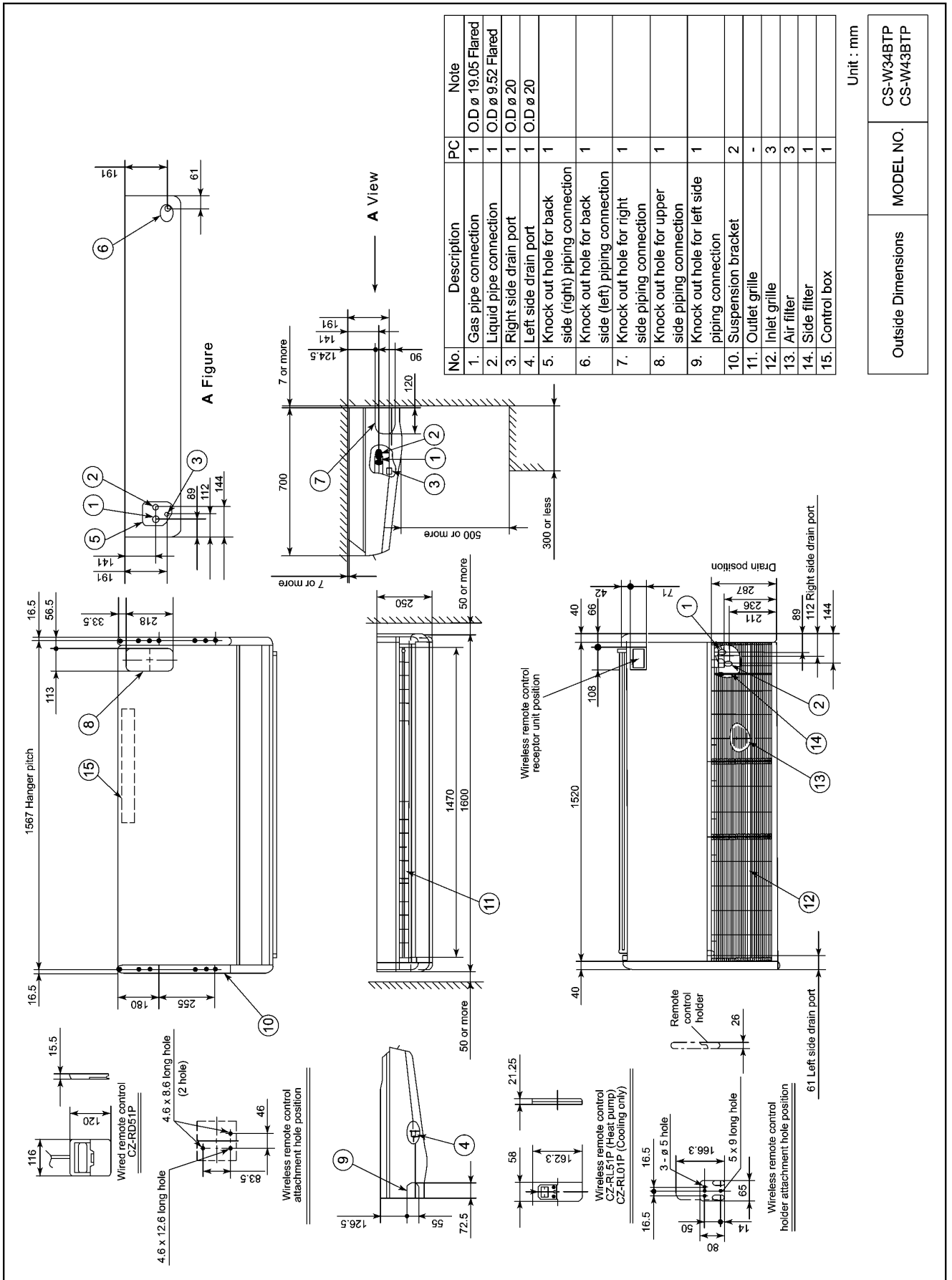

6 CIRCUIT DIAGRAM

CS-W50BTP

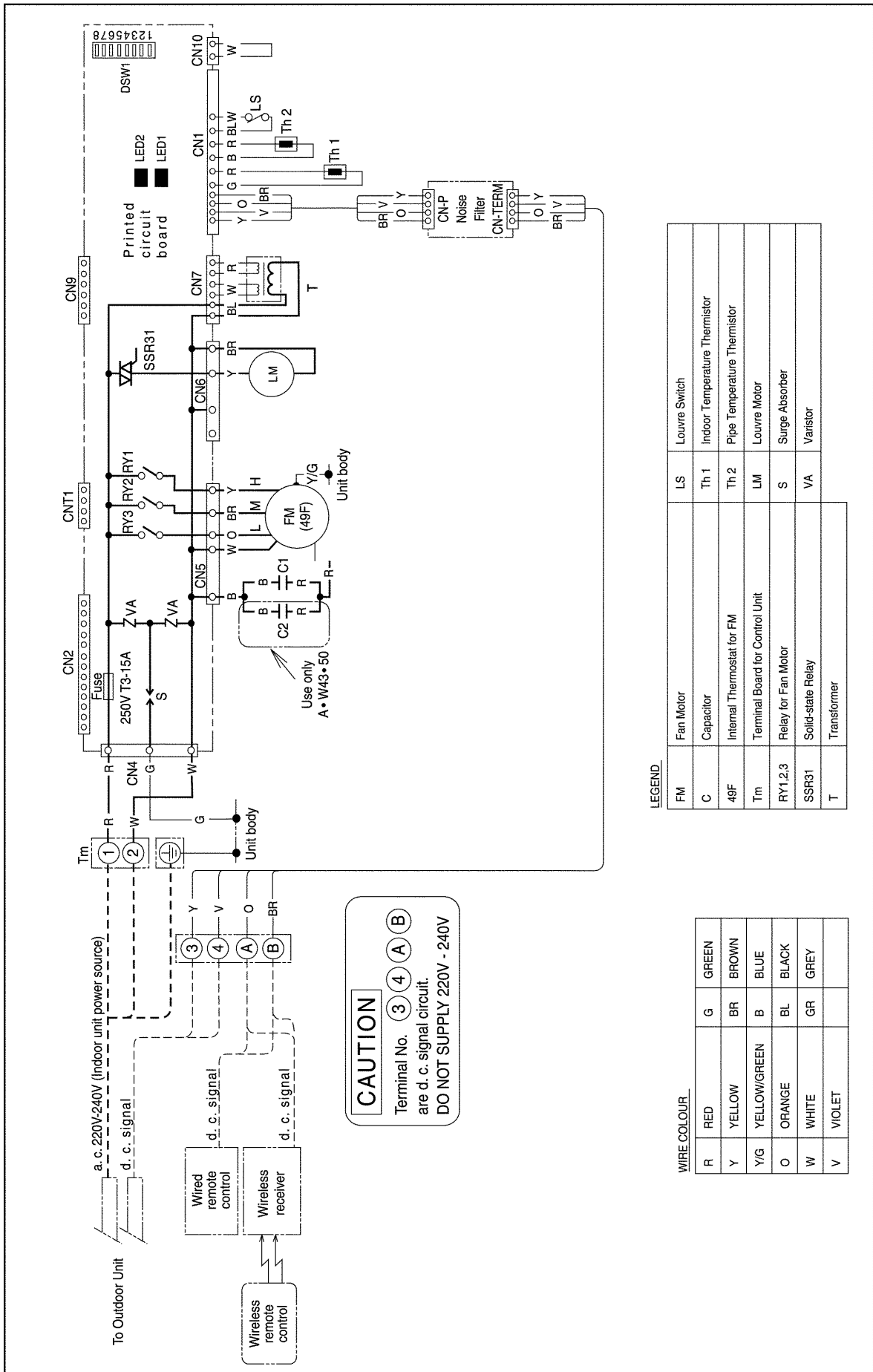

CAUTION
Terminal No. ③ ④ ① ②
are d. c. signal circuit.
DO NOT SUPPLY 220V - 240V

WIRE COLOUR

R	RED	G	GREEN
Y	YELLOW	BR	BROWN
Y/G	YELLOW/GREEN	B	BLUE
O	ORANGE	BL	BLACK
W	WHITE	GR	GREY
V	VIOLET		

LEGEND

FM	Fan Motor	LS	Louvre Switch
C	Capacitor	Th 1	Indoor Temperature Thermistor
49F	Internal Thermostat for FM	Th 2	Pipe Temperature Thermistor
Tm	Terminal Board for Control Unit	LM	Louvre Motor
RY1,2,3	Relay for Fan Motor	S	Surge Absorber
SSR31	Solid-state Relay	VA	Varistor
T	Transformer		

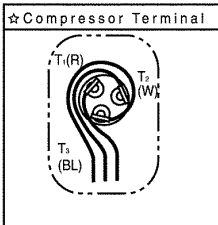
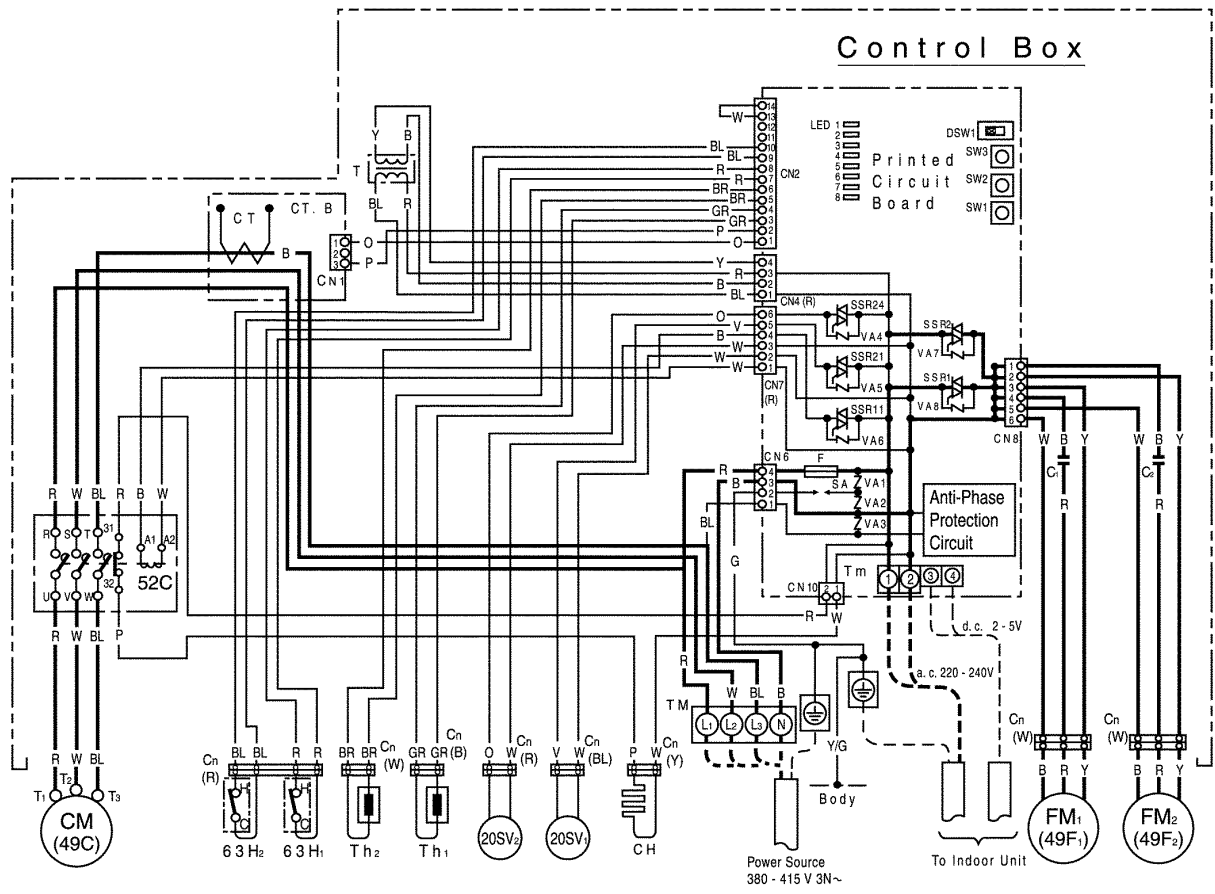

WIRE COLOUR

R	RED	W	WHITE	BL	BLACK
Y	YELLOW	BR	BROWN	V	VIOLET
B	BLUE	P	PINK	G	GREEN
O	ORANGE	GR	GREY		
Y/G	YELLOW / GREEN				

LEGEND

CM	Compressor Motor	20SV ₁	Reversing Valve	Printed Circuit Board	
FM _{1,2}	Fan Motor (Outdoor Unit)	20SV ₂	Bypass Magnetic Valve	SA	Surge Absorber
52C	Magnetic Contactor for CM	TM	Terminal Board for Main Circuit	VA ₁₋₈	Varistor
C _{1,2}	Capacitor for FM _{1,2}	CT.B	Current Trans Board	F	Fuse 250V T 6.3A
CH	Crankcase Heater for CM	Th ₁	Thermistor (Compressor discharger temp.)	CN ₁₋₁₀	Connector
63H ₁	High Pressure Switch	Th ₂	Thermistor (Heat exchanger outlet temp.)	SSR _{12,14}	Solid State Relay
63H ₂	High Pressure Switch on Heat-pump	CT	Current Transformer	SSR _{21,24}	Solid State Relay
Cn	Connector	49C	Internal Protector for CM	Tm	Terminal Board for Control Circuit
T	Transformer	49F _{1,2}	Internal Protector for FM _{1,2}		

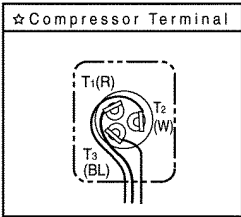
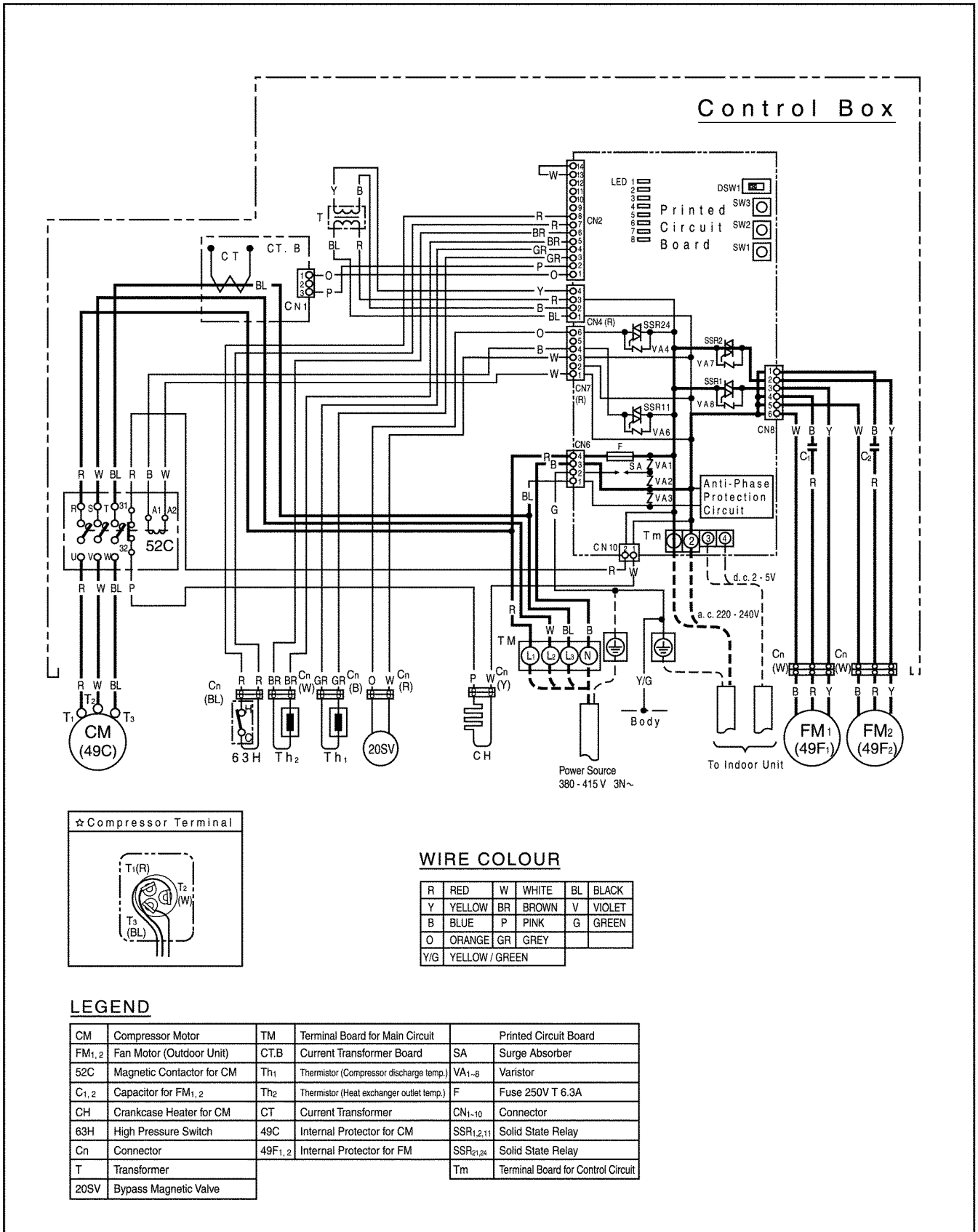

WIRE COLOUR

R	RED	W	WHITE	BL	BLACK
Y	YELLOW	BR	BROWN	V	VIOLET
B	BLUE	P	PINK	G	GREEN
O	ORANGE	GR	GREY		
Y/G	YELLOW / GREEN				

LEGEND

CM	Compressor Motor	TM	Terminal Board for Main Circuit		Printed Circuit Board
FM _{1,2}	Fan Motor (Outdoor Unit)	CT.B	Current Transformer Board	SA	Surge Absorber
52C	Magnetic Contactor for CM	Th ₁	Thermistor (Compressor discharge temp.)	VA ₁₋₈	Varistor
C _{1,2}	Capacitor for FM _{1,2}	Th ₂	Thermistor (Heat exchanger outlet temp.)	F	Fuse 250V T 6.3A
CH	Crankcase Heater for CM	CT	Current Transformer	CN ₁₋₁₀	Connector
63H	High Pressure Switch	49C	Internal Protector for CM	SSR _{1,2,11}	Solid State Relay
Cn	Connector	49F _{1,2}	Internal Protector for FM	SSR _{21,24}	Solid State Relay
T	Transformer			Tm	Terminal Board for Control Circuit
20SV	Bypass Magnetic Valve				

APPLICABLE FOR ALL MODELS

● INDOOR UNIT
PRINTED CIRCUIT BOARD

S PHASE	4
SURGE ABSORBER	3
_____	2
R PHASE	1

CN4

INDOOR FAN H	6
INDOOR FAN M	5
INDOOR FAN L	4
_____	3
COM	2
COM (SPH)	1

CN5

AIR SWING LOUVRE MOTOR	6
HEATER	5
_____	4
COM	3
COM	2
_____	1

CN6

TRANSFORMER 1ST (R PH)	6
TRANSFORMER 2ND	5
TRANSFORMER	4
TRANSFORMER 1ST (S PH)	3
TRANSFORMER 2ND	2
TRANSFORMER	1

CN7

ROOM THERMISTOR	12
ROOM THERMISTOR	11
PIPE THERMISTOR	10
PIPE THERMISTOR	9
_____	8
_____	7
LOUVRE SW	6
LOUVRE SW	5
COMMUNICATION WITH OUTDOOR UNIT	4
COMMUNICATION WITH OUTDOOR UNIT	3
WIRED REMOTE CONTROL	2
WIRED REMOTE CONTROL	1

CN1

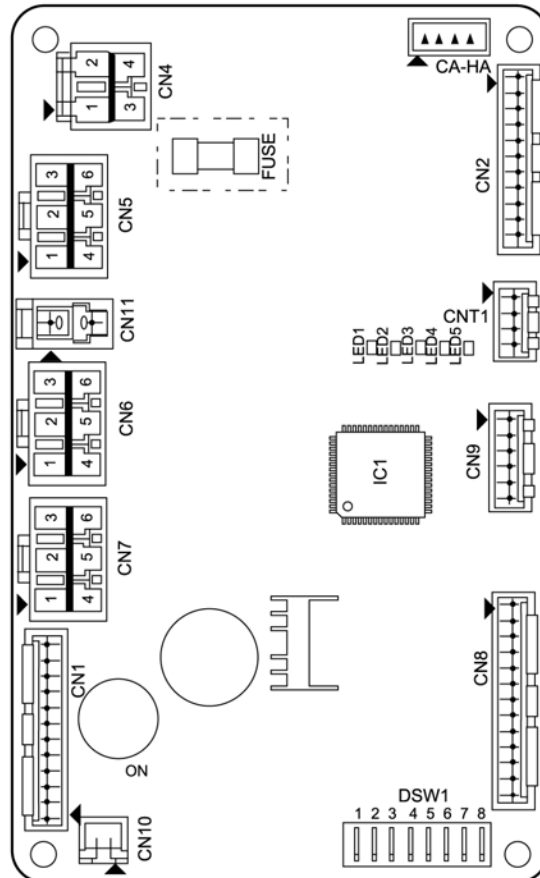

APPLICABLE FOR ALL MODELS

● OUTDOOR UNIT
PRINTED CIRCUIT BOARD

_____	14
_____	13
GND	12
DEMAND INPUT	11
GND	10
HEATING PRESSURE SW	9
GND	8
HIGH PRESSURE SW	7
GND	6
PIPE TEMP SENSOR	5
GND	4
DISCHARGE TEMP SENSOR	3
GND	2
CT	1

CN2

TRANSFORMER 2ND(S)	4
TRANSFORMER 1ST(R)	3
TRANSFORMER 2ND(R)	2
TRANSFORMER 1ST(S)	1

CN4

LIQUID BYPASS valve(R)	6
REVERSING valve(R)	5
COMPRESSOR relay(R)	4
LIQUID BYPASS valve(S)	3
REVERSING valve(S)	2
COMPRESSOR relay(S)	1

CN7

R Phase	4
S Phase	3
Earth	2
T Phase	1

CN6

*1. HEAT PUMP MODEL ONLY
*2. CU-34BB type
CU-43BB type } Model only
CU-50BB type }

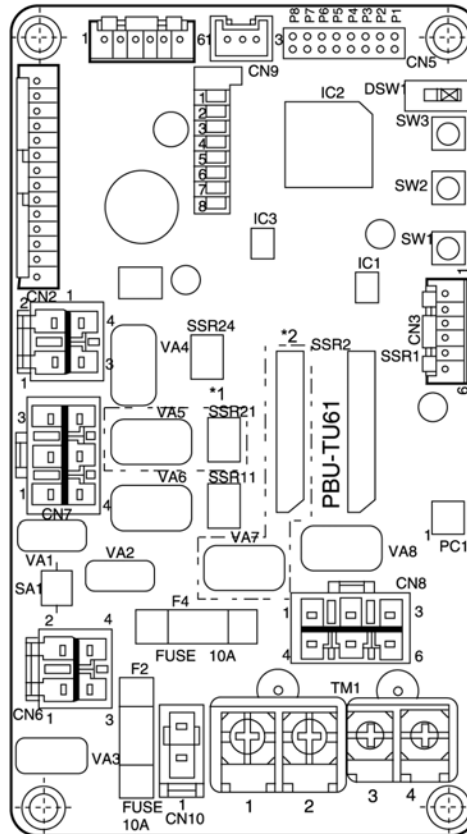

COMMUNICATION WITH INDOOR UNIT	4
COMMUNICATION WITH INDOOR UNIT	3
S Phase	2
R Phase	1

TM1

S Phase	1
Fan2(R)	2
Fan1(R)	3
S Phase	4
S Phase	5
S Phase	6

CN8

CRANKCASE HEATER(S)	1
CRANKCASE HEATER(R)	2

CN10

APPLICABLE FOR ALL MODELS

● INDOOR UNIT
PRINTED CIRCUIT BOARD
(SCHEMATIC DIAGRAM)

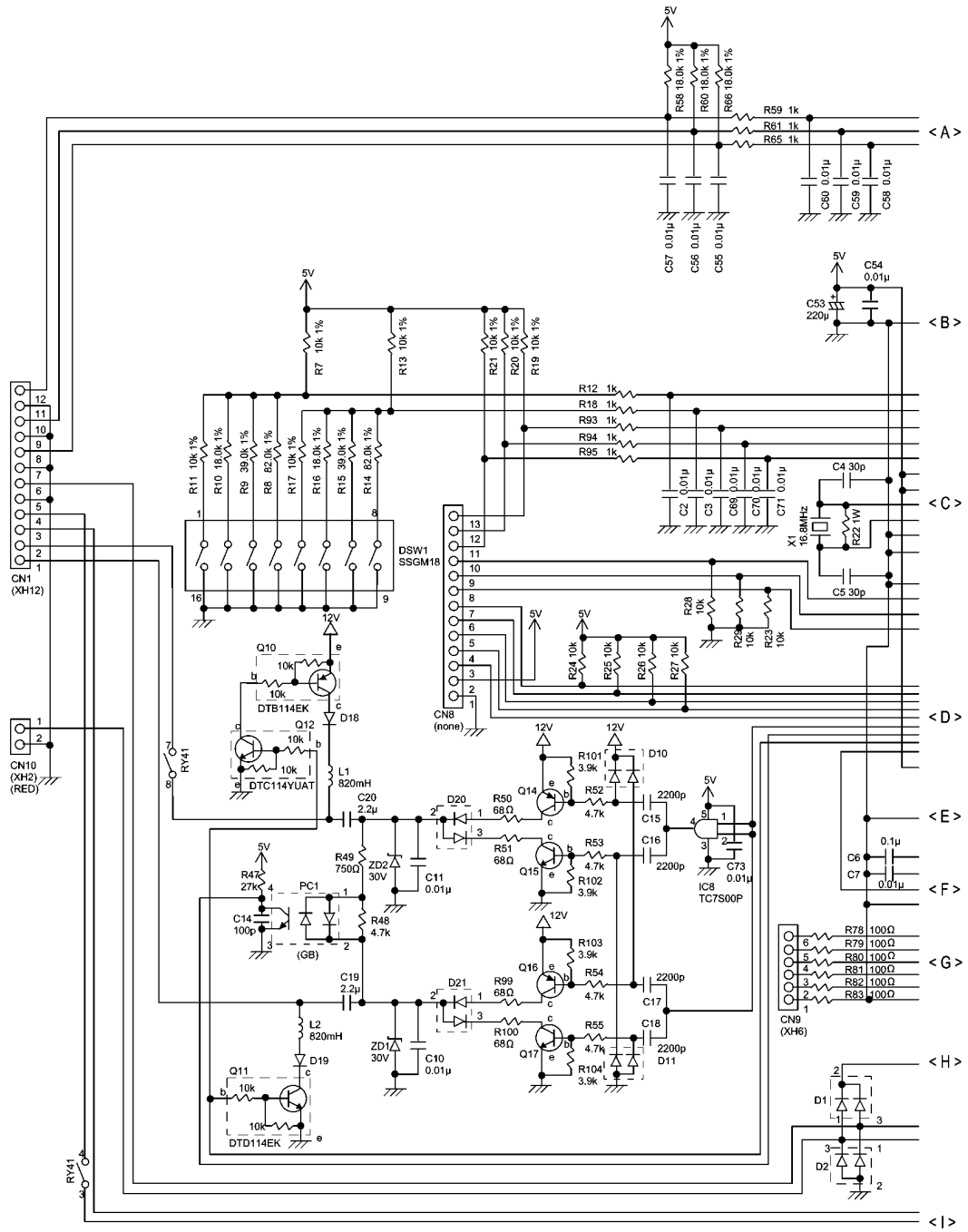

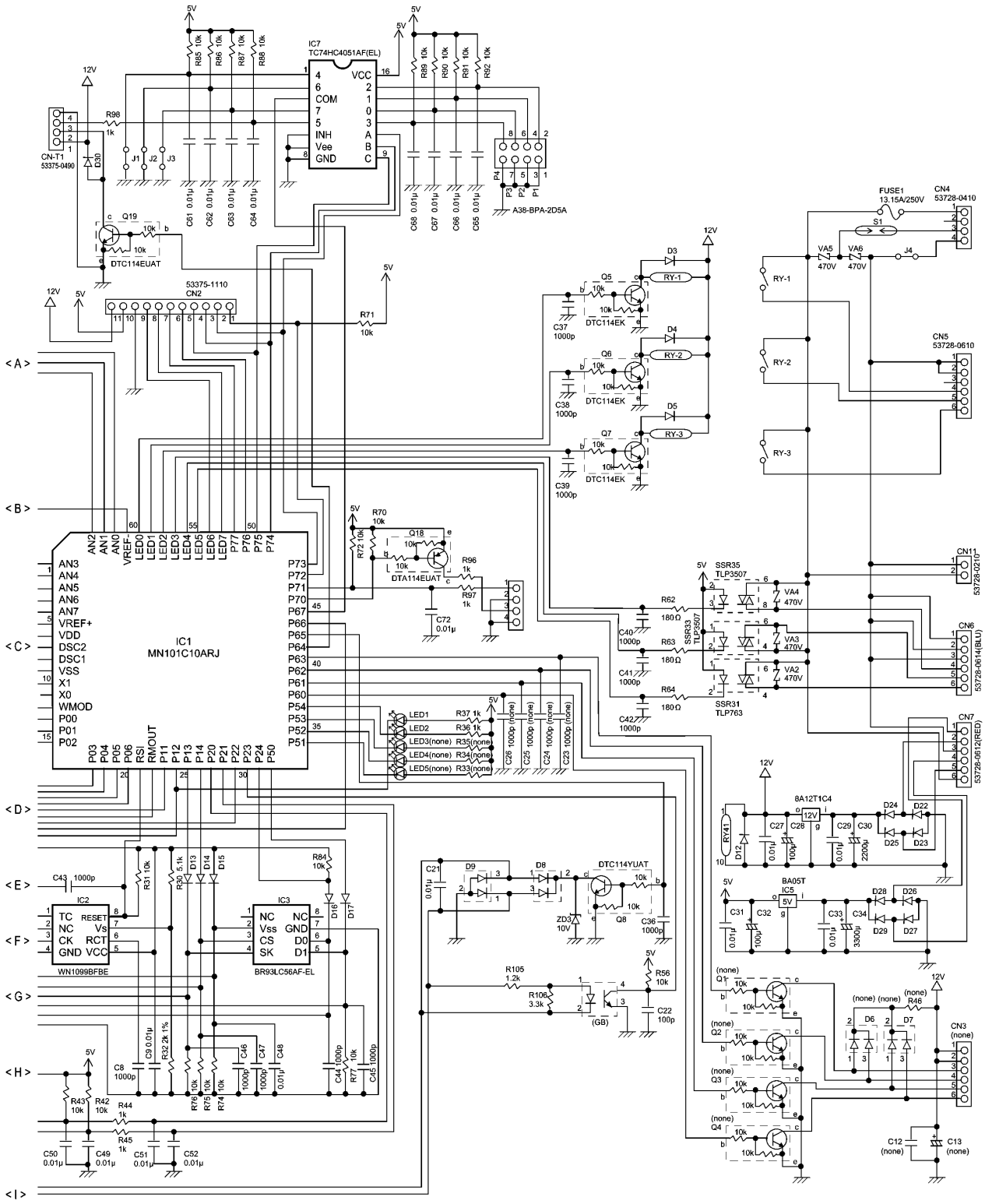

● OUTDOOR UNIT
PRINTED CIRCUIT BOARD
(SCHEMATIC DIAGRAM)

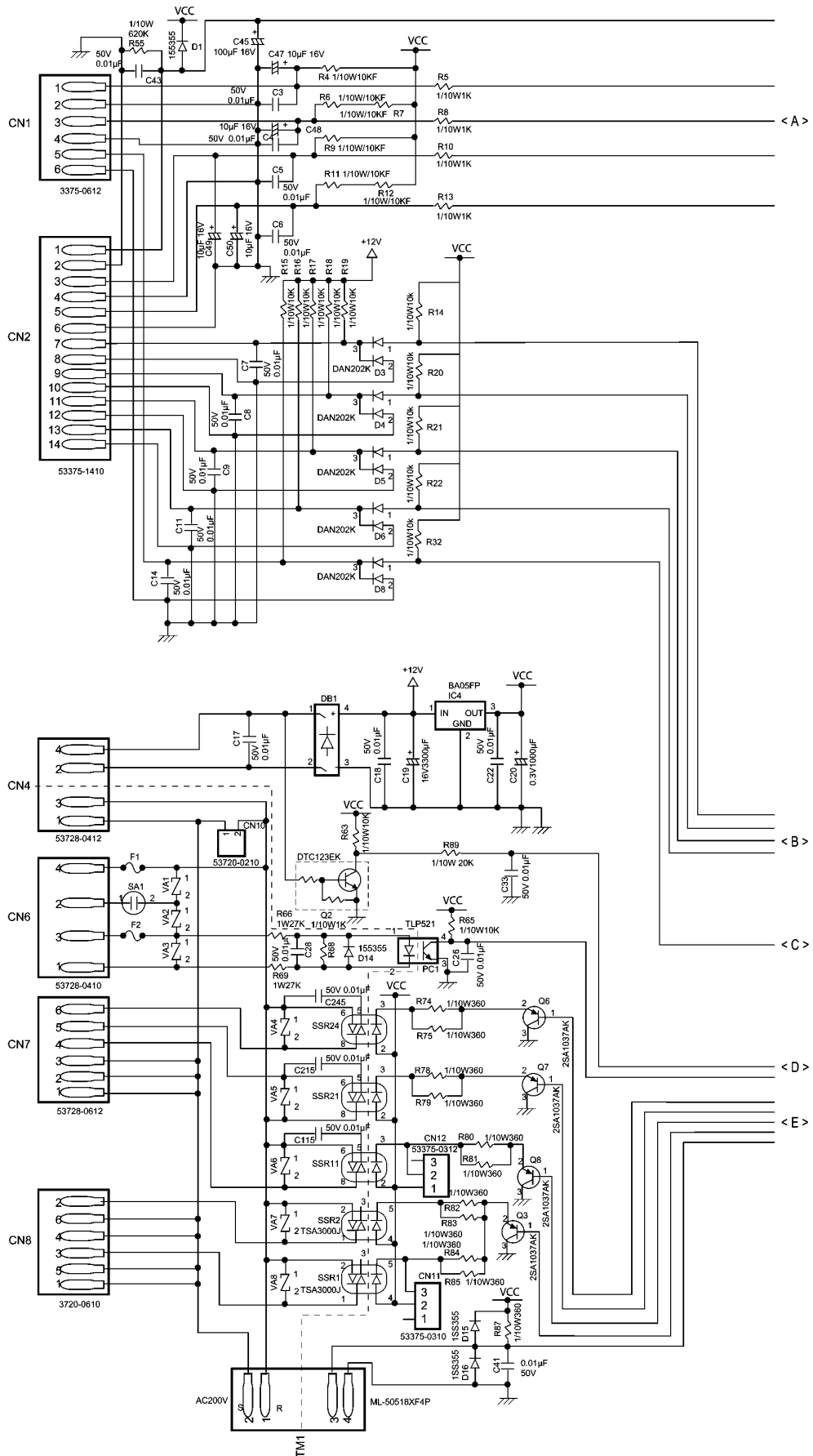

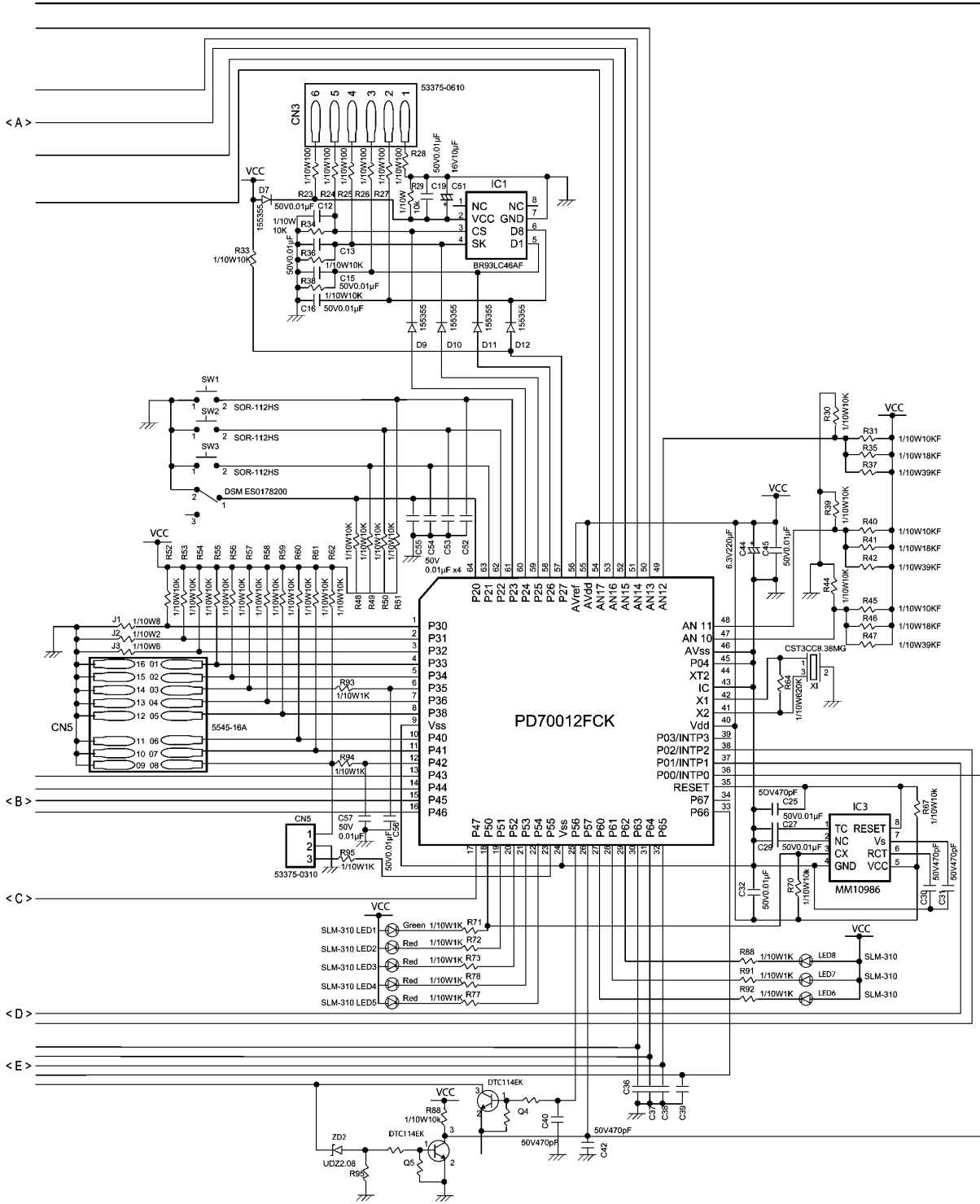

	A742583	A742584	A742585	A742586	A742587	A742588	A742589	A742590
D14	NONE	AVLB	←	←	NONE	AVLB	NONE	←
C26	NONE	AVLB	←	←	NONE	AVLB	NONE	←
C28	NONE	AVLB	←	←	NONE	AVLB	NONE	←
R66	NONE	AVLB	←	←	NONE	AVLB	NONE	←
R68	NONE	AVLB	←	←	NONE	AVLB	NONE	←
R69	NONE	AVLB	←	←	NONE	AVLB	NONE	←
J1	NONE	←	←	←	AVLB	←	←	NONE
J2	AVLB	NONE	←	←	←	AVLB	NONE	←
PC1	NONE	AVLB	←	←	←	NONE	AVLB	←
SSR2	NONE	←	AVLB	←	←	NONE	←	←
VA3	NONE	AVLB	←	←	←	AVLB	NONE	←
VA5	AVLB	←	←	←	NONE	←	←	AVLB
VA7	NONE	←	AVLB	←	←	←	←	←
SSR21	AVLB	←	←	←	NONE	←	←	AVLB

AVLB - Available
 NONE - Not available

APPLICABLE FOR ALL MODELS

● WIRED REMOTE CONTROL
PRINTED CIRCUIT BOARD
(SCHEMATIC DIAGRAM)

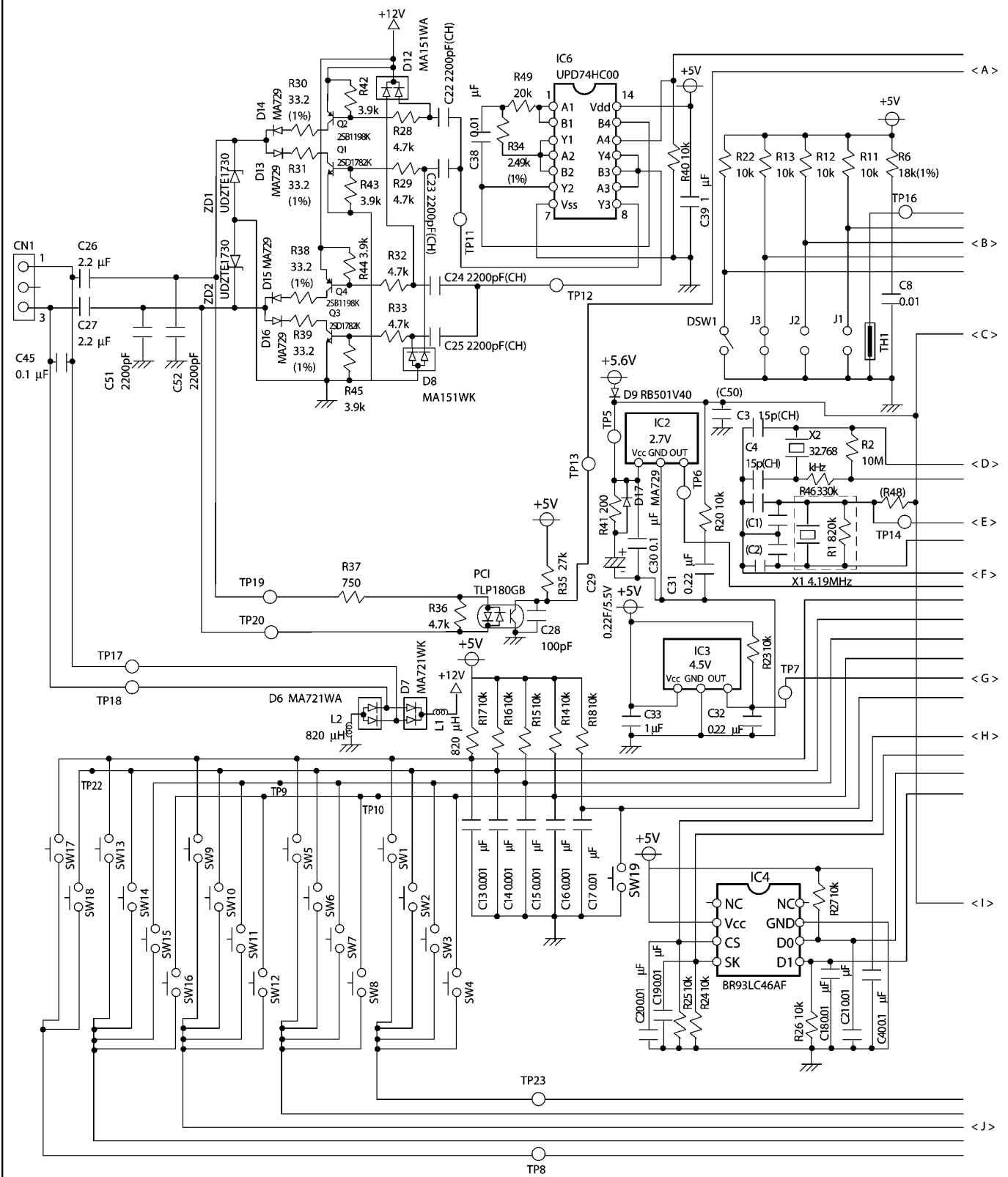

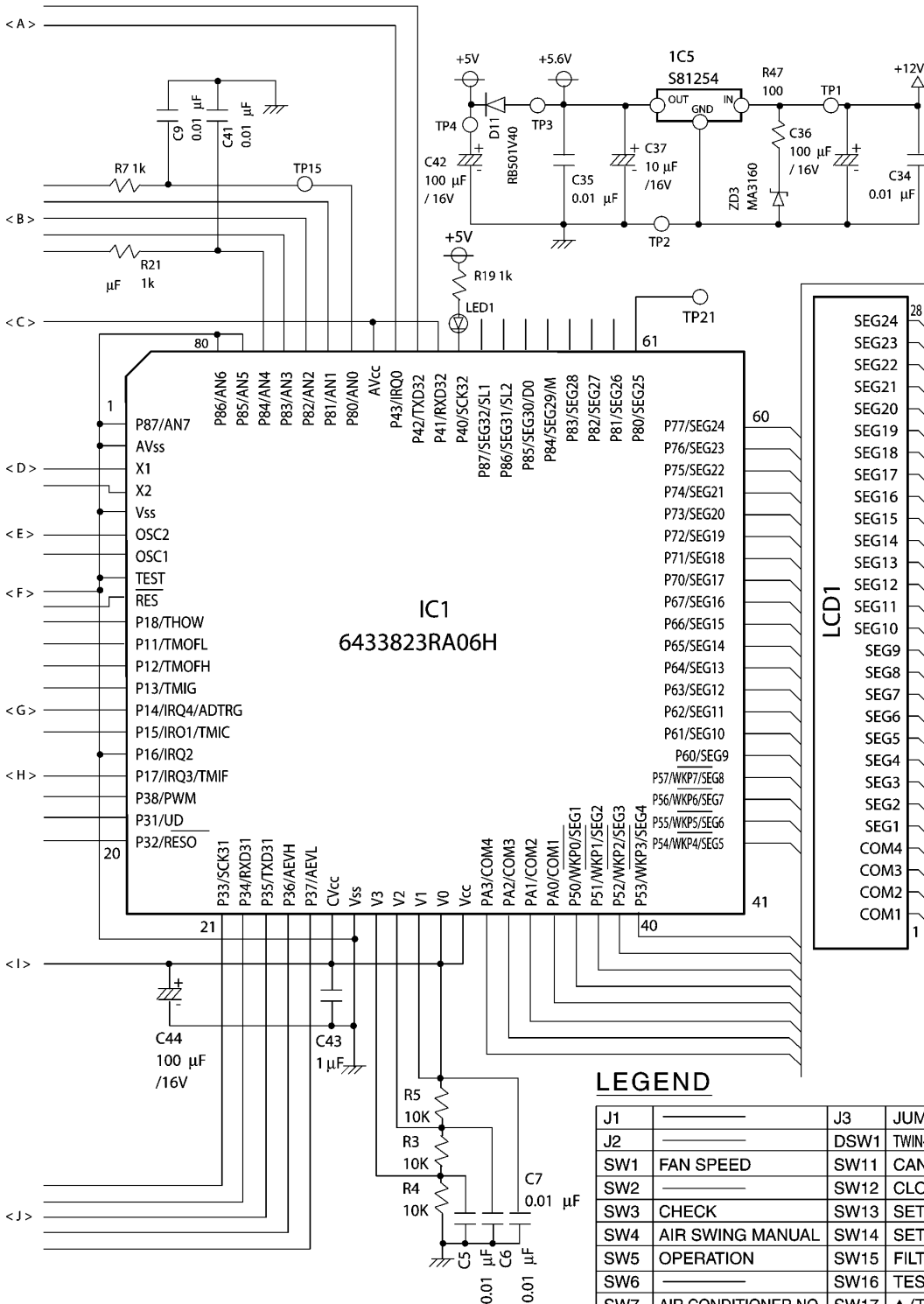

LEGEND

J1	_____	J3	JUMPER
J2	_____	DSW1	TWIN-TRIPPLE SETTING (ON:SAVE, OFF:MAIN)
SW1	FAN SPEED	SW11	CANCEL
SW2	_____	SW12	CLOCK
SW3	CHECK	SW13	SET TEMPERATURE UP
SW4	AIR SWING MANUAL	SW14	SET TEMPERATURE DOWN
SW5	OPERATION	SW15	FILTER RESET
SW6	_____	SW16	TEST RUN
SW7	AIR CONDITIONER NO.	SW17	▲ (TO SET A LATER TIME)
SW8	AIR SWING AUTO	SW18	▼ (TO SET AN EARLIER TIME)
SW9	SELECT	SW19	OFF / ON
SW10	SET	SW20	_____

● WIRELESS REMOTE CONTROL
PRINTED CIRCUIT BOARD
(SCHEMATIC DIAGRAM)

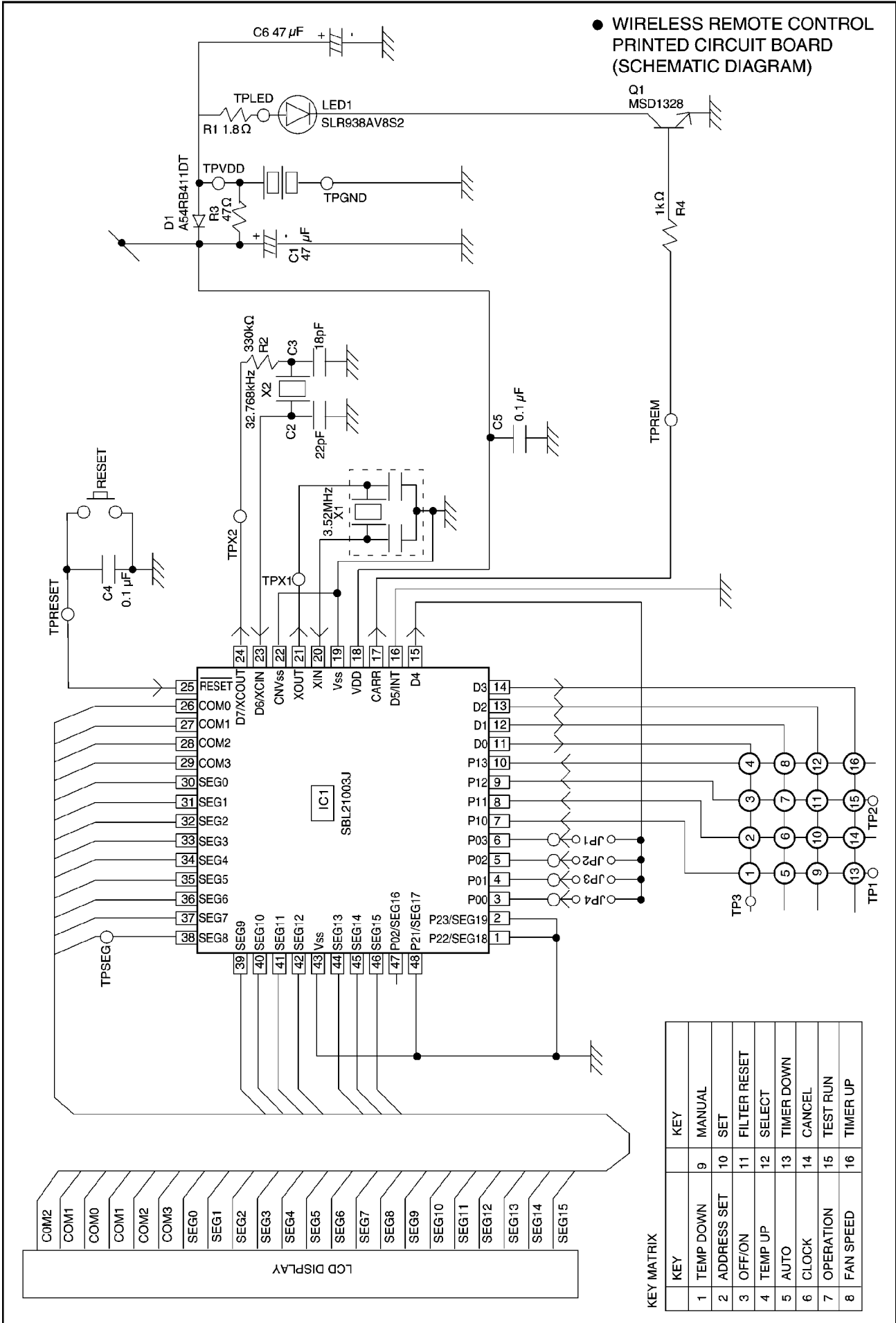

KEY MATRIX

KEY	KEY	KEY
1	TEMP DOWN	9
2	ADDRESS SET	10
3	OFF/ON	11
4	TEMP UP	12
5	AUTO	13
6	CLOCK	14
7	OPERATION	15
8	FAN SPEED	16
		9
		10
		11
		12
		13
		14
		15
		16

7 OPERATING INSTRUCTION

7.1. Wired Remote Control (OPTIONAL PARTS)

Name and function of each part

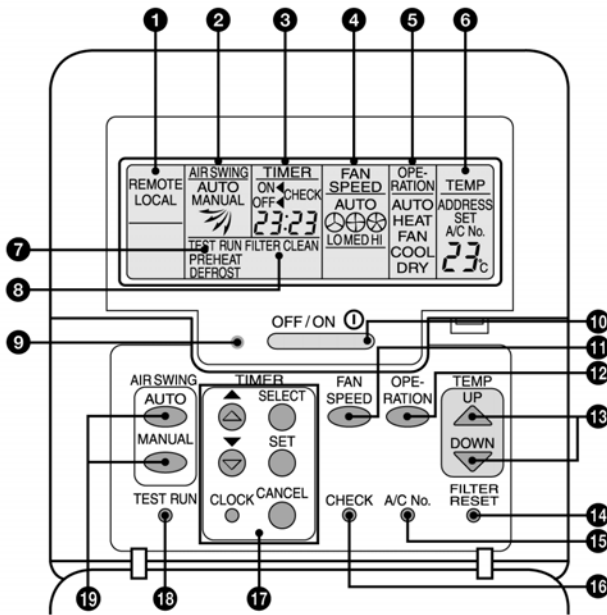

- 1 REMOTE**
The OFF/ON button cannot be used.
LOCAL
All remote control functions can be used.
- 2 Airflow direction setting display**
- 3 Timer/time setting display**
- 4 Fan speed display**
- 5 Operation mode selection display**
- 6 Temperature setting display (16°C - 31°C)**
- 7 TEST RUN**
Indicates that the unit is running in test operation mode.
PREHEAT
Indicates that the unit is running in pre-heating mode.
DEFROST
Indicates that the unit is running in dedroasting mode.
- 8 FILTER CLEAN**
(Appears after the cumulative running time reaches approximately 2,500 hours of operation.)

- 9 Operation indicator**
Lights up in red when the unit is operating.
- 10 OFF/ON button**
Used to start and stop the operation.
- 11 FAN SPEED button**
Used to select the fan speed of high (HI), medium (MED), low (LO) or autofan (AUTO).
- 12 OPERATION button**
Used to select the operation of FAN, COOL, DRY, AUTO or HEAT.
- 13 TEMP (UP/DOWN) buttons**
Used to select the desired temperature.
- 14 FILTER RESET button**
Press to reset the "FILTER CLEAN" after washing the filter.
- 15 A/C No. button***
This switch is used during group control. It is not needed for normal operation.
- 16 CHECK button**
Press this button if the check display is flashing.
- 17 TIMER/CLOCK SET buttons**
Used to set the timer operation and the current time.
- 18 TEST RUN button***
- 19 AIR SWING (AUTO/MANUAL) buttons**
Used to determine the air swing condition, either auto or manual.

NOTES:

- Ensure that the correct button is pressed as simultaneous pressing of the multiple buttons will not make the setting correct.
- The illustration above is for explanatory purposes only. The appearance will be different during actual operation.
- Do not operate the remote control with wet hands. Otherwise, electric shock or malfunction may occur.
- Do not press the remote control buttons with sharp object as this may damage the remote control.
- Buttons marked with * are not needed for normal operation. If one of these buttons is pressed by mistake, press the same button once more to cancel the operation.
- When the power resumed after power failure, the unit will restart automatically with all the previous settings preserved by the memory function. (Auto restart function)

7.2. Wireless Remote Control (OPTIONAL PARTS)

Name and function of each part

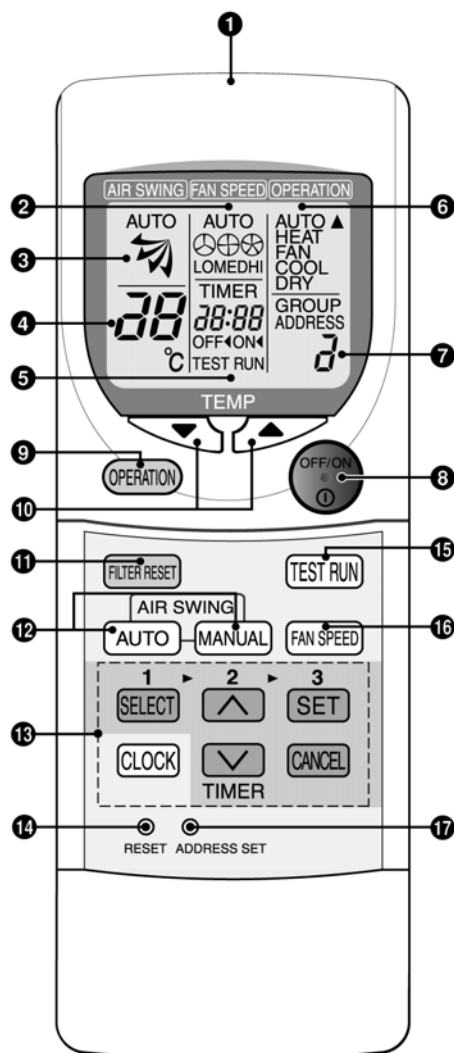

- 1 Transmitter**
Transmits the remote control signal.
- 2 Fan speed display**
- 3 Airflow direction setting display**
- 4 Temperature setting display (16°C - 31°C)**
- 5 Timer/time setting display**
Shows the timer operation setting time or the current time.
- 6 Operation selection display**
- 7 Address number display**
- 8 OFF/ON button**
Used to start and stop the operation.
- 9 OPERATION button**
Used to select the operation of FAN, COOL, DRY, AUTO or HEAT.
- 10 TEMP (UP/DOWN) buttons**
Used to select the desired temperature.
- 11 FILTER RESET button**
Press to cancel the "FILTER" indicator light on the ray receiver.
- 12 AIR SWING (AUTO/MANUAL) buttons**
Used to determine the air swing condition, either auto or manual.
- 13 TIMER/CLOCK SET buttons**
Used to set the timer operation and the current time.
- 14 RESET button**
Pressing this button will clear all the settings from memory. You will then need to make the settings again.
- 15 TEST RUN button***
- 16 FAN SPEED button**
Used to select the fan speed of high (HI), medium (MED), low (LO) or autofan (AUTO).
- 17 ADDRESS SET button***
Used to change the address setting when using more than one indoor unit.

NOTES:

- Ensure that the correct button is pressed as simultaneous pressing of the multiple buttons will not make the setting correct.
- The illustration above is for explanatory purpose only. The appearance will be different during actual operation.
- If using the wireless remote control in conjunction with the wired remote control, the settings made from the wireless remote control will appear on the wired remote control display (except when making timer settings).
- Buttons marked with * are not needed for normal operation. If one of these buttons is pressed by mistake, press the same button once more to cancel the operation.
- When the power resumed after power failure, the unit will restart automatically with all previous settings preserved by the memory function. (Auto restart function)

8 REFRIGERATION CYCLE

CS-W50BTP/CU-W50BBP8

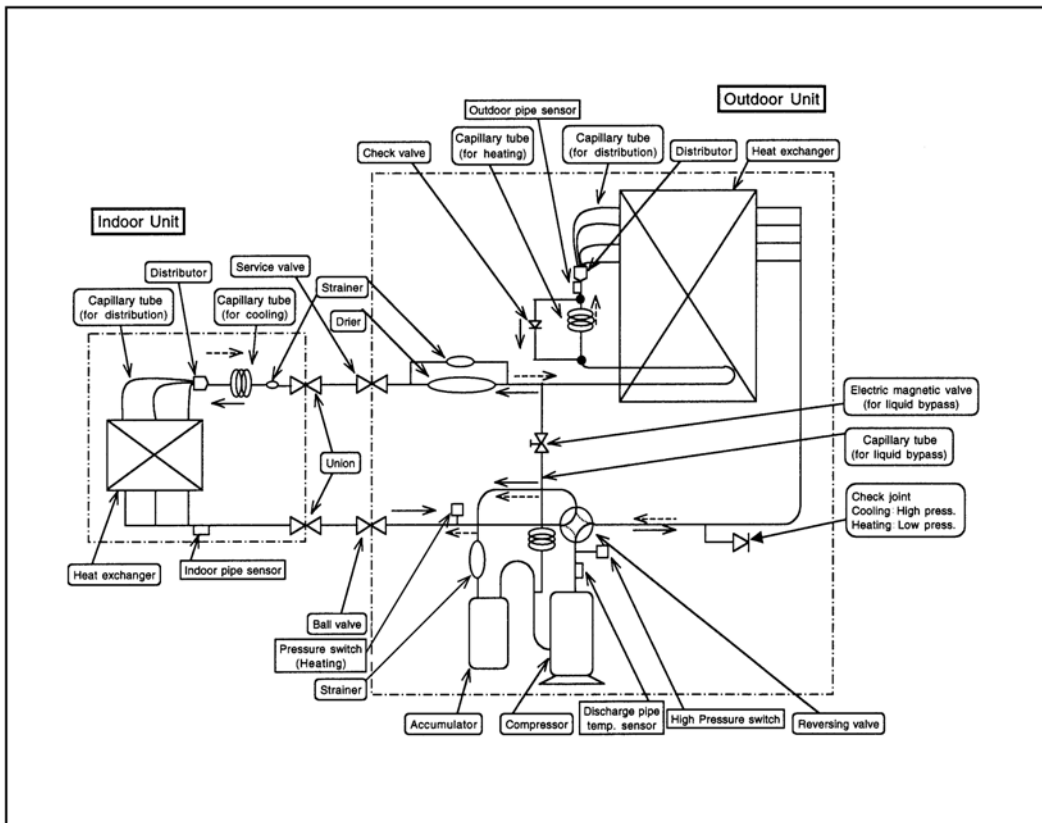

CS-W50BTP/CU-V50BBP8

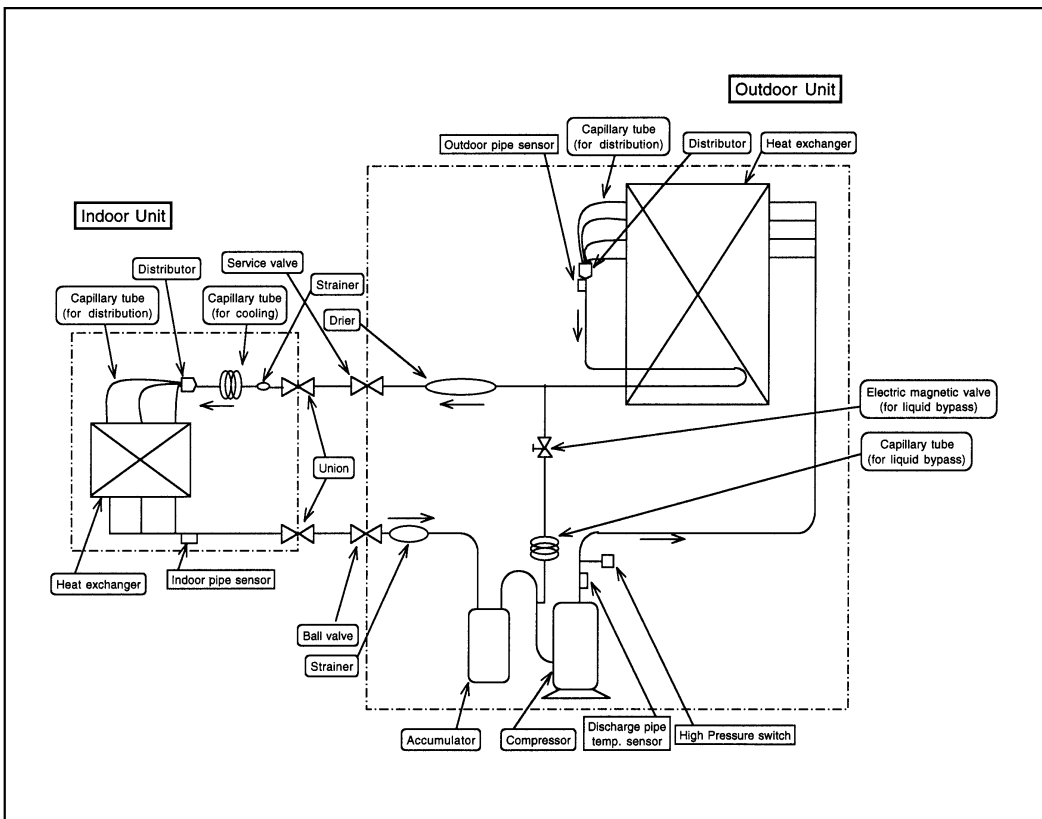

9 OPERATION RANGE

Power Supply

The applicable voltage range for each unit is given in the following table. The working voltage among the three phases must be balanced within a 3% deviation from each voltage at the compressor terminals. The starting voltage must be higher than 85% of the rated voltage.

Power Supply

MODEL CU-	Unit Main Power		Applicable Voltage	
	Phase, Volts	Hz	Max	Min
V50BBP8	3N~380	50	418	342
W50BBP8	3N~400	50	440	360
	3N~415	50	457	374

Indoor and Outdoor Temperature

- Cooling only type

Model 50Hz CU-V50BBP8

Operating	Hz	Indoor Temp. (D.B./W.B.) (°C)		Outdoor Temp. (D.B./W.B.) (°C)	
		Max	Min	Max	Min
Cooling	50	32/23	21/15	43/-	-5/-

- Heat pump type

Model 50Hz CU-W50BBP8

Operating	Hz	Indoor Temp. (D.B./W.B.) (°C)		Outdoor Temp. (D.B./W.B.) (°C)	
		Max	Min	Max	Min
Cooling	50	32/23	21/15	43/-	-5/-
Heating	50	27/-	16/-	24/18	-10/-

10 PIPE LENGTH

■ CORRECTION OF COOLING CAPACITY AND HEATING CAPACITIES

Correction of cooling and heating capacities according to the connecting pipe length.

The data of cooling capacities (marked on the name plate) are based on 7.5 meters connecting pipe and horizontal installation. For other pipe length of other installation multiply by the following correction factor to determine the revised cooling capacity.

[Cooling]

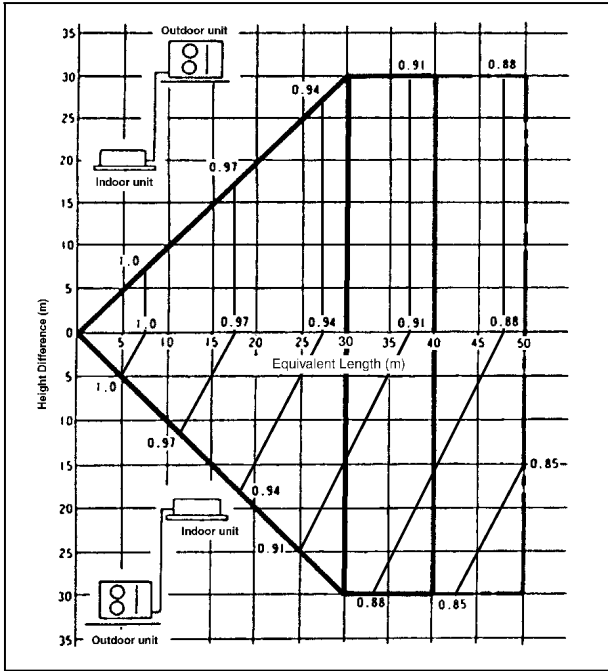

[Heating]

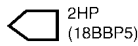
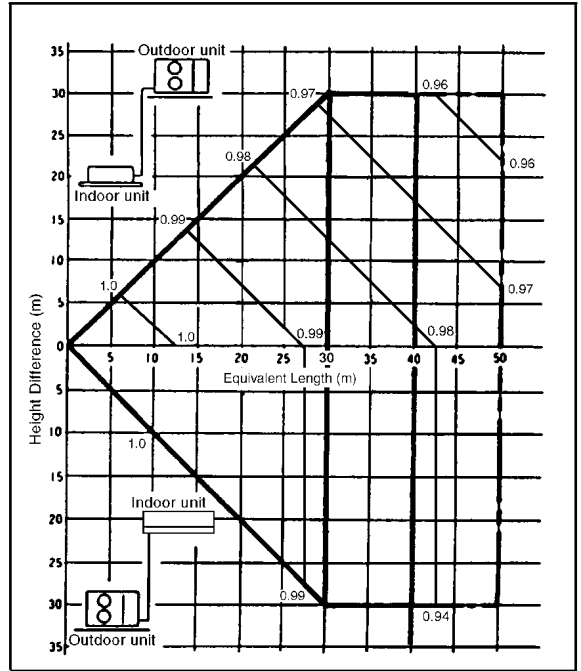

2HP
(18BBP5)

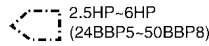

2.5HP-6HP
(24BBP5-50BBP8)

Equivalent Length = actual pipe length + number of elbow
x ELE

ELE : equivalent length of elbow

Outer diameter of gas side pipe mm (inch)	ELE 
12.7 (1/2)	0.20
15.88 (5/8)	0.25
19.05 (3/4)	0.35
9.52 (3/8)	0.18

■ REFRIGERANT ADDITIONAL CHARGE

1. Piping installation by standard piping

- At the time of shipment from the factory, this unit is charged with enough refrigerant for an equivalent pipe length of 30m. (Refer to the following table)

But when the piping length exceeds 30m, additional charge is required according to the following table.

Example:

CU-V50BBP8

In case of 50m long pipe (one way), the amount of refrigerant to be replenished is: $(50 - 30) \times 50 = 1,000\text{g}$

■ Cooling only type

Model Name	Standard piping specification			
	Liquid piping (dia.mm)	Gas piping (dia.mm)	Gas charge- less length (m)	Additional gas volume (g/m)
CU-V50BBP8	9.52	19.05	30	50

Model Name	Existing piping specification (Larger piping)			
	Liquid piping (dia.mm)	Gas piping (dia.mm)	Gas charge- less length (m)	Addition gas volume (g/m)
CU-V50BBP8	12.7	19.05	7	100

■ Heat pump type

Model Name	Standard piping specification			
	Liquid piping (dia.mm)	Gas piping (dia.mm)	Gas charge- less length (m)	Additional gas volume (g/m)
CU-W50BBP8	9.52	19.05	30	50

Model Name	Existing piping specification (Larger piping)			
	Liquid piping (dia.mm)	Gas piping (dia.mm)	Gas charge- less length (m)	Addition gas volume (g/m)
CU-W50BBP8	12.7	19.05	17	100

2. Piping installation by existing piping

The above models change the liquid pipe size of the previous series. It is to use the existing piping by adjusting the refrigerant gas volume.

Please do correct piping installation referring to the above table.

⚠ Attention

- Please do not decrease the gas piping size. (It causes the breakdown of the compressor).
- The equivalent piping length and the cooling and heating capacity change rate are same as the standard piping specification.

11 OPERATING CHARACTERISTIC

HEAT PUMP MODEL

Model		Main Power Source		Compressor Motor			Indoor Unit Fan Motor		Outdoor unit Fan Motor		Electrical Data (50Hz)	
		Voltage	Frequency	S.C.	R.C. (A)	IPT (kW)	R.C.	IPT	R.C.	IPT	F.C.(A)	IPT(kW)
		(v)	(Hz)	(A)	Cool/Heat	Cool/Heat	(A)	(kW)	(A)	(kW)	Cool/Heat	Cool/Heat
HEAT PUMP MODEL	CS-W50BTP	380	50	69	8.62 / 8.62	4.97 / 5.07	0.74	0.16	0.99	0.22	9.20 / 9.20	5.35 / 5.45
	CU-W50BBP8	400	50	69	8.62 / 8.62	4.95 / 5.05	0.73	0.17	1.02	0.23	9.20 / 9.20	5.35 / 5.45
		415	50	69	8.61 / 8.61	4.93 / 5.03	0.73	0.17	1.04	0.25	9.20 / 9.20	5.35 / 5.45

COOLING ONLY MODEL

Model		Main Power Source		Compressor Motor			Indoor Unit Fan Motor		Outdoor unit Fan Motor		Electrical Data (50Hz)	
		Voltage	Frequency	S.C.	R.C. (A)	IPT (kW)	R.C.	IPT	R.C.	IPT	F.C.(A)	IPT(kW)
		(v)	(Hz)	(A)	Cool	Cool	(A)	(kW)	(A)	(kW)	Cool	Cool
COOLING ONLY MODEL	CS-W50BTP	380	50	69	8.62	4.97	0.74	0.16	0.99	0.22	9.20	5.35
	CU-V50BBP8	400	50	69	8.62	4.95	0.73	0.17	1.02	0.23	9.20	5.35
		415	50	69	8.61	4.93	0.73	0.17	1.04	0.25	9.20	5.35

Legend : S.C. = Starting Current, R.C. = Running Current, IPT = Power Consumption

12 FAN PERFORMANCE

●CS-W50BTP

ITEM \ Model		Indoor Unit			Outdoor Unit
		CS-W50BTP			CU-V/W50BBP8
Mode		Hi	Me	Lo	Hi
Air Volume	m ³ /min	35	30	28	95
Running Current	A	0.73	0.58	0.55	1.02
Power Consumption	kW	0.17	0.14	0.13	0.25
Fan Speed	r/min	1324	1177	1118	720

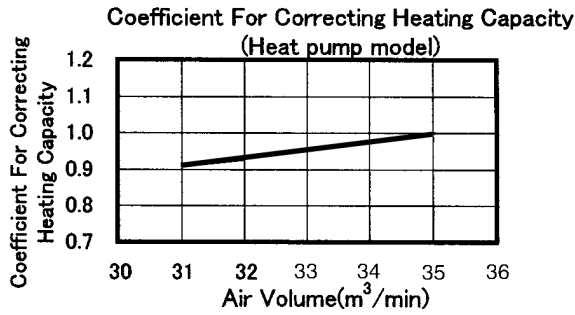
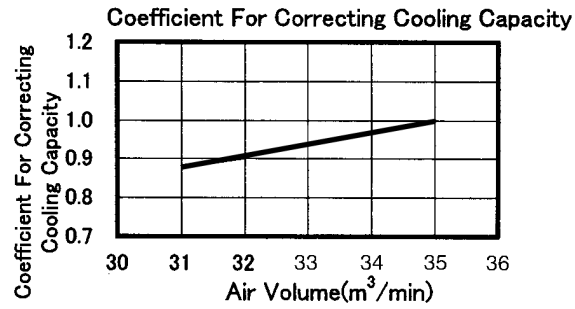

13 SAFETY DEVICE

INDOOR UNIT

Indoor unit	Heat pump model		CS-W50BTP
	Cooling only model		
For Fan Motor Protection, Internal Protector (49F)	OFF	°C	135
	ON	°C	85
For Control Protection, Fuse	CUT	A	3.15

OUTDOOR UNIT

Outdoor Unit	Heat pump model	50Hz	CU- W50BBP8
	Cooling only model	50Hz	CU- V50BBP8
For Refrigerant Cycle, High Pressure Switch (63H ₁)	OFF	MPa (*1)	3.1
	ON	MPa (*1)	2.3
For Compressor Over Current Protection	OFF (Heat pump)	A	15
	OFF (Cooling only)	A	15
		A	-
	RESET	-	Automatic
Discharge Temp. Protection, Discharge Temp. Thermistor (Th1)	Compressor OFF	°C	120
Liquid Compression Protection, Crankcase Heater	Input power	W	34~41
Compressor Protection, Internal Protector	OFF	°C	145
		50Hz	-
	ON	60Hz	-
		°C	61
	Trip time	50Hz	3-10sec/ 48A
		60Hz	-
For Fan Motor Protection, Internal Protector (49F)	OFF	°C	135
	ON	°C	85
Heating Control Pressure Switch (Heat pump only) (Fan speed) (63H ₂)	OFF	MPa (*1)	2.50
	ON	MPa (*1)	2.05
Cooling Control, Heat Exchanger Outlet Temp. Thermistor (Th2)	Control method	Th ≥ 30 degree celcius ----- High speed Th < 30 degree celcius -----5 speed step control	
For Control Protection, Fuse	CUT	A	6.3

(*1) 1MPa = 10.2 kgf/cm²

(*2) Head Thermostat only for W/V28BBP8 & V24BBP8

14 COMPONENT SPECIFICATION

Compressor

Model		Heat pump model	50Hz	CU-W50BBP8
		Cooling only model	50Hz	CU-V50BBP8
			60Hz	-
Compressor Model			single-phase 3-phase	- ZR68KCE-TFD
Compressor Type		SCROLL		
No. of Cylinders		1		
Revolution		r/min	2,900	
Piston Displacement		m ³ /h	16.18	
Motor Type	Starting Method	Direct on-line Starting		
	Rated Output	kW		
	Poles	4.1		
	Insulation Class	2 E		
Oil	Type	MMMAPOE		
	Charge	L 1.8		

Evaporator

Models			CS-W50BTP
	Tube Material	Copper tube	
	Outer Diameter	mm	7.0
	Thickness	mm	0.27
	Row	3	
	No. of Tubes/Row	12	
	Fin Material	Aluminium	
	Thickness	mm	0.105
	Fin Pitch	NO./inch	19
	Fin Surface	Z Slit fin	
	Total Face Area	m ²	0.464
Fan	Type	Sirocco fan	
	No. of /Unit	4	
Fan Motor	Starting Method	Direct on-line Starting	
	Rated Output	kW	
	Poles	0.14	
	Phase	4	
	Insulation Class	Single-Phase E	

Condenser

Models		Heat pump model	CU-W50BBP8
		Cooling only model	CU-V50BBP8
	Tube Material	Copper tube	
	Outer Diameter	mm	9.52
	Thickness	mm	0.3
	Row	2	
	No. of Tubes/Row	46	
	Fin Material	Aluminium	
	Thickness	mm	0.105
	Fin Pitch	NO./inch	14
	Fin Surface	X-Louvre fin	
	Total Face Area	m ²	1.05
Fan	Type	Propeller Fan	
	No. of /Unit	2	
Fan Motor	Starting Method	Direct on-line Starting	
	Rated Output	kW	
	Poles	0.055 x 2	
	Phase	6	
	Insulation Class	Single-Phase E	

15 CAPACITY AND POWER CONSUMPTION

15.1. HEATING PERFORMANCE

Model	Heating capacities are based on conditions below.
CS-W50BTP CU-W50BBP8	<ul style="list-style-type: none"> ● 3 phase, 50Hz, 400V ● Indoor temperature 20°C D.B.T. ● Outdoor temperature 7°C D.B. 6°C W.B.T. ● Standard air volume 35m³/min
Heating capacity 14.0 kW	

Inlet Air		Outdoor Temperature (°C W.B.T.)							
Air Volume (m ³ /min)	Entering Air D.B.T. (°C)	-6°C		0°C		6°C		12°C	
		H.C.	IPT	H.C.	IPT	H.C.	IPT	H.C.	IPT
35	15	11.68	3.82	14.00	4.36	16.8	5.18	19.5	6.10
	20	11.04	4.03	13.20	4.63	16.0	5.45	19.2	6.32
	25	10.40	4.25	12.48	4.91	15.2	5.72	18.4	6.52

H.C. = Heating Capacity

IPT = Power Consumption

15.2. COOLING PERFORMANCE

CS-W50BTP

Model	Cooling capacities are based on conditions below.
CS-W50BTP Cooling capacity 14.0 kW	<ul style="list-style-type: none"> ● 1 phase, 50Hz, 230V ● Indoor temperature 27°C D.B.T. 19°C W.B.T. ● Outdoor temperature 35°C D.B.T. ● Standard air volume 35m³/min

Cooling capacity

Indoor Air Temperature		Outdoor Temperature (°C D.B.T.)				
		25	30	35	40	43
		TC	TC	TC	TC	TC
D.B.	W.B.	kW	kW	kW	kW	kW
23	17	14.57	14.00	13.17	12.18	11.47
	19	15.39	14.91	14.15	13.19	12.52
	22	16.81	16.36	15.61	14.60	13.91
25	17	14.40	13.84	13.04	12.09	11.41
	19	15.41	14.88	14.07	13.11	12.42
	22	16.80	16.29	15.49	14.43	13.78
27	17	14.22	13.68	12.91	12.00	11.36
	19	15.43	14.84	14.00	13.02	12.32
	22	16.79	16.22	15.37	14.28	13.65
29	17	14.19	13.68	12.88	12.10	11.50
	19	15.40	14.84	14.01	13.12	12.47
	22	16.72	16.15	15.27	14.30	13.64
32	17	14.17	13.69	11.97	12.16	11.59
	19	15.37	14.84	14.01	13.19	12.57
	22	16.67	16.10	15.26	14.31	13.64

Cooling power consumption

Indoor Air Temperature		Outdoor Temperature (°C D.B.T.)				
		25	30	35	40	43
		IPT	IPT	IPT	IPT	IPT
D.B.	W.B.	kW	kW	kW	kW	kW
23	17	4.26	4.61	5.02	5.51	5.84
	19	4.51	4.89	5.33	5.84	6.19
	22	4.88	5.28	5.75	6.31	6.69
25	17	4.26	4.61	5.01	5.48	5.80
	19	4.54	4.90	5.34	5.83	6.18
	22	4.90	5.29	5.76	6.29	6.67
27	17	4.27	4.60	5.01	5.44	5.77
	19	4.56	4.92	5.35	5.82	6.16
	22	4.93	5.31	5.78	6.28	6.66
29	17	4.24	4.59	4.95	5.31	5.54
	19	4.53	4.91	5.29	5.68	5.92
	22	5.00	5.40	5.82	6.25	6.51
32	17	4.23	4.58	4.91	5.23	5.38
	19	4.52	4.90	5.24	5.58	5.75
	22	5.04	5.47	5.85	6.23	6.57

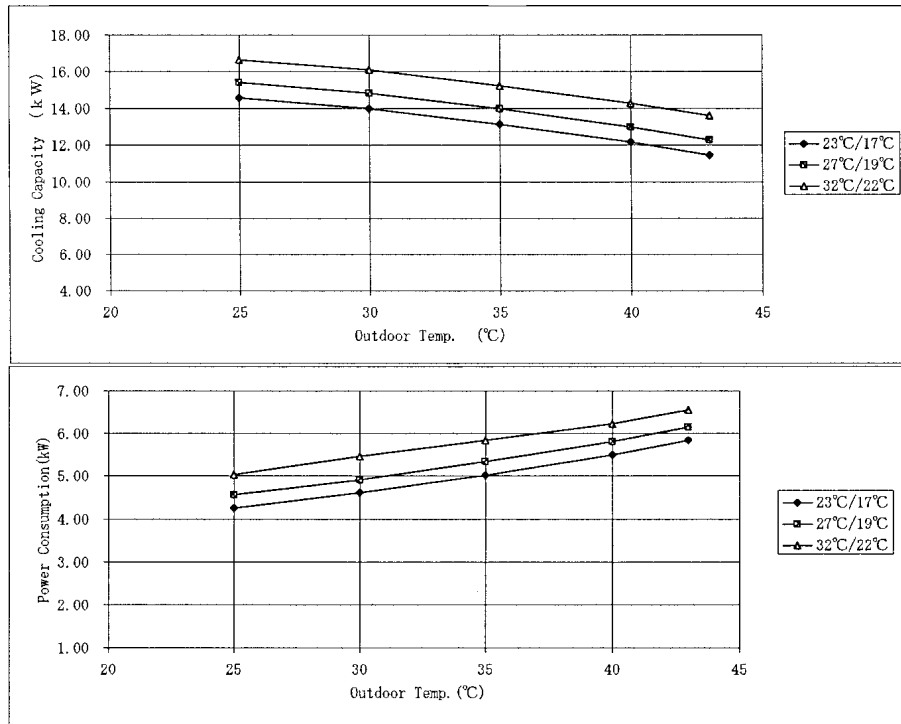

TC = Total Cooling Capacity

IPT = Power Consumption

16 DISCHARGE AND SUCTION PRESSURE

● SATURATION TEMPERATURE OF DISCHARGE AND SUCTION PRESSURE

HEATING (Heat pump model only)

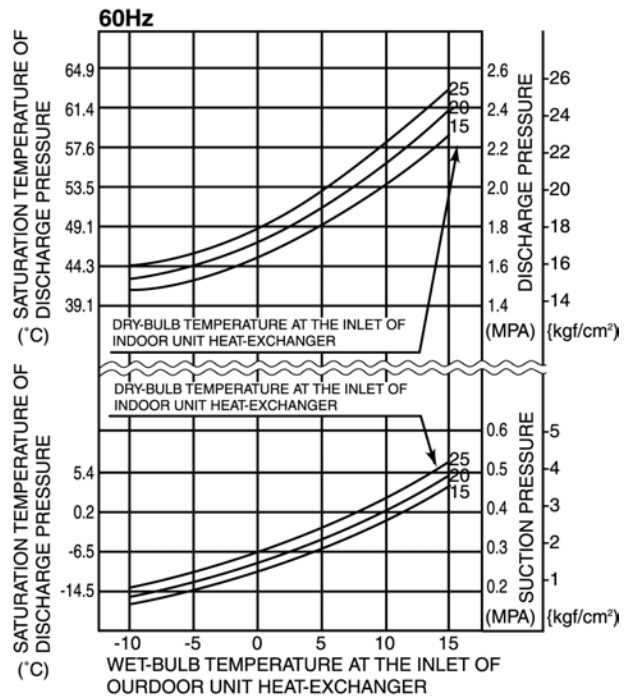
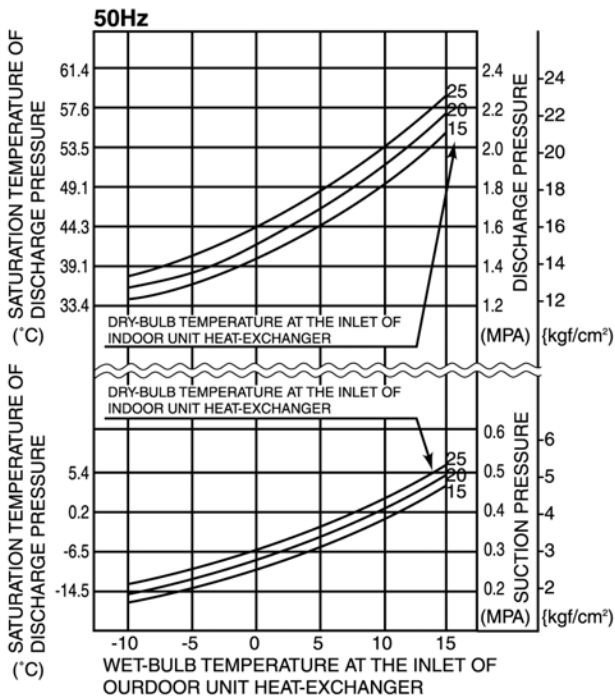

COOLING

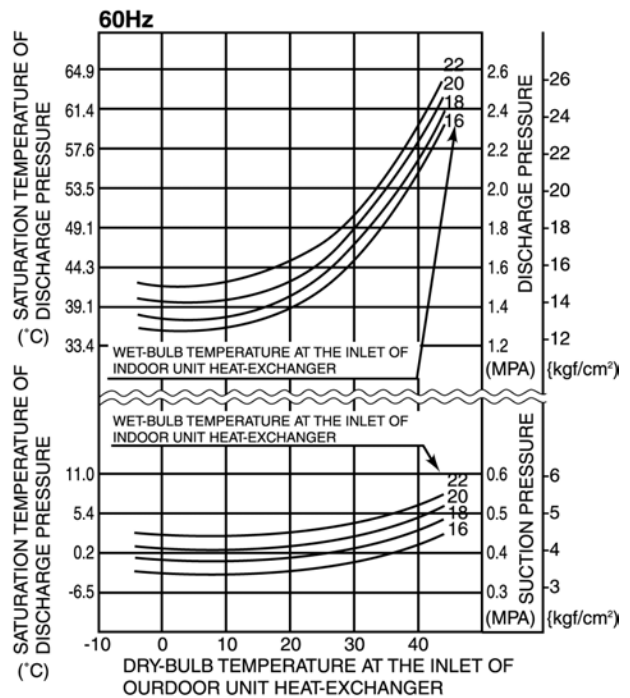
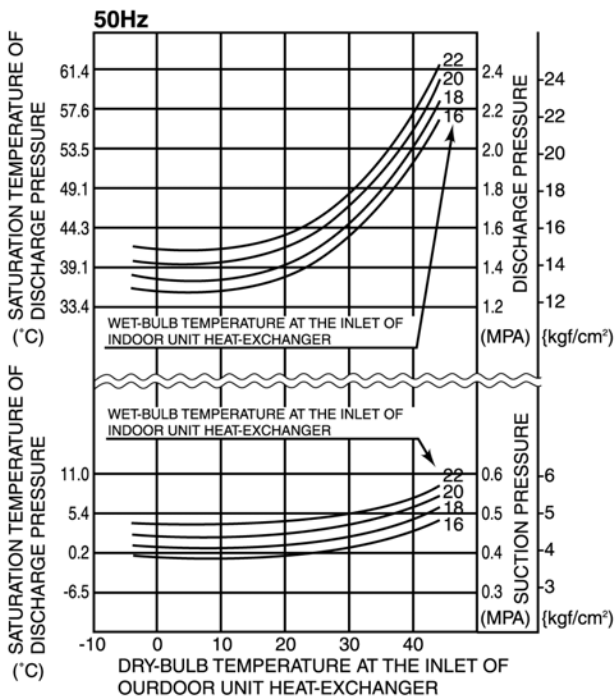

17 REACHING DISTANCE

● CS-W50BTP

■ >1.0m/s ■ >0.5m/s ■ >0.3m/s

< Cooling > (ANGLE AT OUTLET 0°)
 (High Speed)
 (VELOCITY AT OUTLET 6.6m/s)

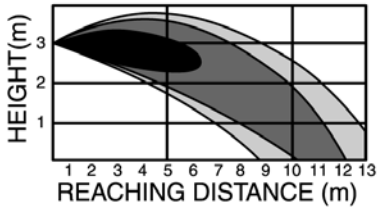

(Medium Speed)
 (VELOCITY AT OUTLET 5.8m/s)

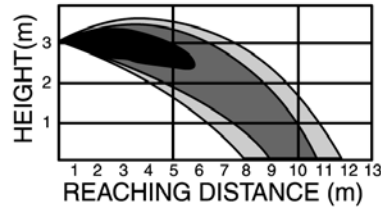

(Low Speed)
 (VELOCITY AT OUTLET 4.9m/s)

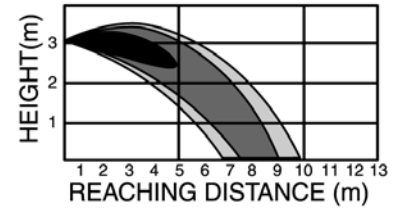

< Heating > (ANGLE AT OUTLET 70°)
 (High Speed)
 (VELOCITY AT OUTLET 6.6m/s)

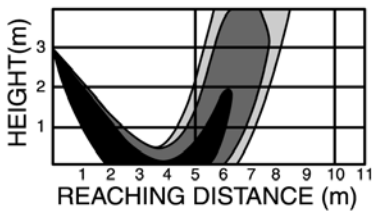

(Medium Speed)
 (VELOCITY AT OUTLET 5.8m/s)

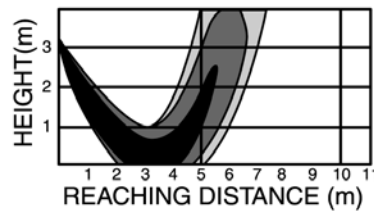

(Low Speed)
 (VELOCITY AT OUTLET 4.9m/s)

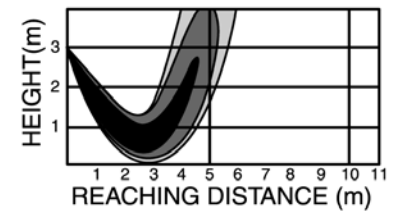

18 SOUND DATA

CS-W50BTP (50Hz)

Octave Band Central Frequency(Hz)

H ○—○
M △—△
L □—□

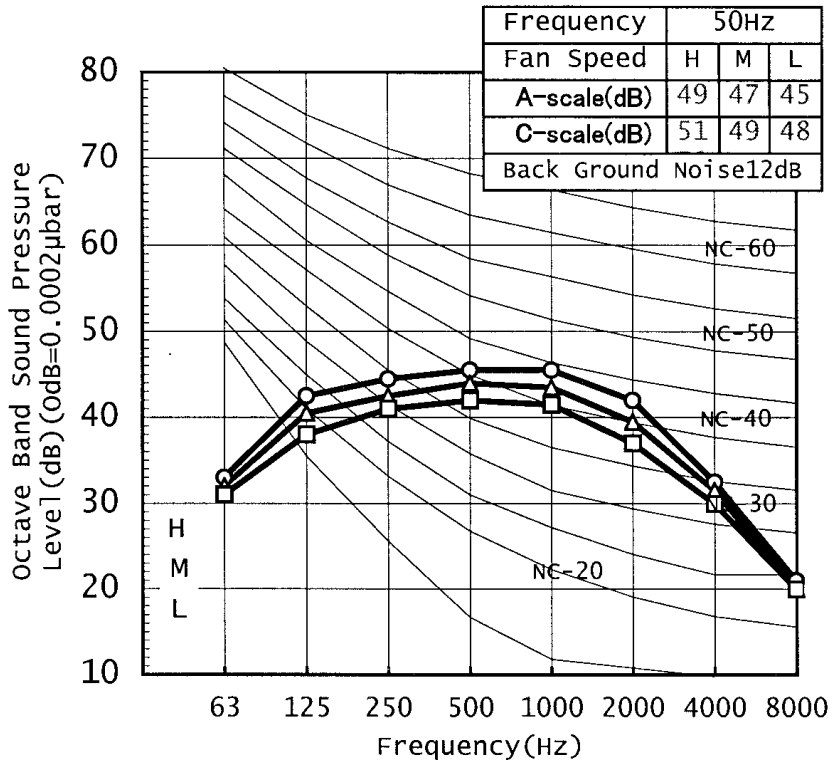

CU-W50BBP8 (Cooling)

Octave Band Central Frequency(Hz)

Frequency	50Hz
Fan Speed	H
A-scale(dB)	56
C-scale(dB)	62
Back Ground Noise	12dB

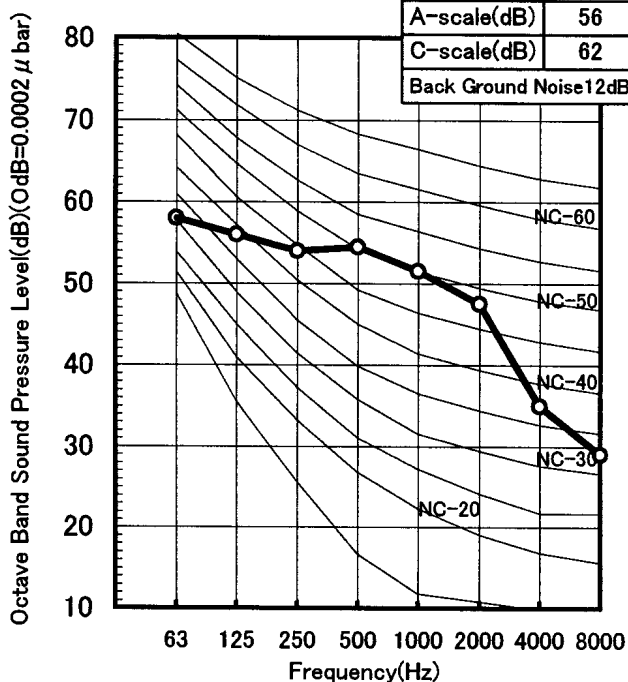

CU-W50BBP8 (Heating)

Octave Band Central Frequency(Hz)

Frequency	50Hz
Fan Speed	H
A-scale(dB)	58
C-scale(dB)	64
Back Ground Noise	12dB

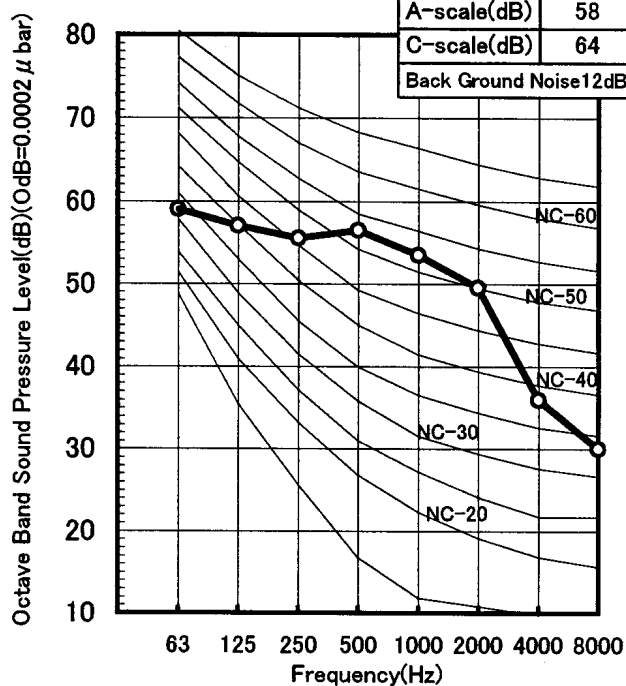

CU-V50BBP8 (Cooling)

Octave Band Central Frequency(Hz)

Frequency	50Hz
Fan Speed	H
A-scale(dB)	56
C-scale(dB)	62
Back Ground Noise	12dB

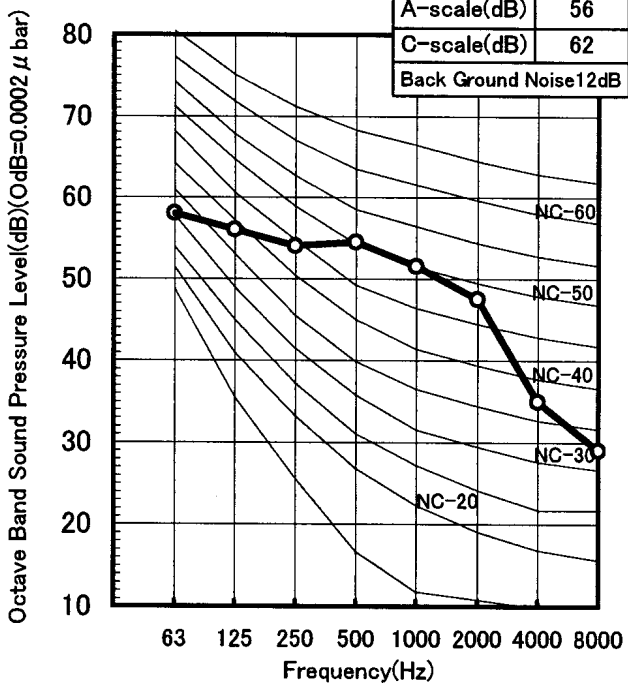

19 TWIN AND TRIPLE

19.1. Twin and Triple Operation

- Simultaneous air conditioning of wide spaces and corners is possible. Indoor units with different horsepowers can even be used in combination.

- Master unit and slave-units can be set automatically in twin and triple systems. No address setting is necessary.
- Multiple indoor units can be operated simultaneously with a single remote control unit. Note that individual operation is not possible.

Twin and Triple Combination Table

Outdoor unit	Simultaneous twin operation		Simultaneous triple operation	
	Standard	Horsepower difference	Standard	Horsepower difference
3.0 HP				
4.0 HP				
5.0 HP				
6.0 HP				

: Outdoor unit capacity
 : Indoor unit capacity

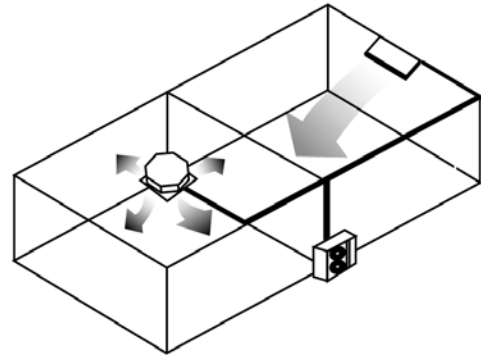

19.1.1. Twin and triple operation setting

- The master unit and slave units are set automatically when the power is turned on. At this time, the indoor unit which is connected to the remote control unit becomes the master unit. (If automatic setting is not possible, carry out the settings manually.)
- No distinction is made between master unit and slave units (slave unit 1 and slave unit 2) at the indoor unit or remote control.
- Install the remote control to the master unit. (It cannot be connected to slave units.)
If indoor unit models with louvres and models without louvres have been connected together, use an indoor unit

- with louvres as the master unit.
- The remote control thermostat can also be set.
- Optional circuit boards can only be installed to the master unit.
- Setting the master unit and slave units can also be carried out manually by using DIP switches. However, manual settings will always take priority. If you have made manual settings but would like to return to using automatic settings, set all slave unit DIP switches (refer to the table below) to the OFF position, and then press the ADDRESS RESET button on the outdoor unit (SW3 on the outdoor unit printed circuit board).
(Do not mix manual settings and automatic settings.)

Manual setting	Master unit	Slave unit	
		Slave unit 1 when connecting a triple system	Slave unit 2 when connecting a triple system
	<ul style="list-style-type: none"> • It is not necessary to operate any switches on the master unit. The unit connected to the remote control will become the master unit. 	ON OFF 1 2 3 4 5 6 7 8 Set No. 8 to ON. All other switches can be ignored. (No. 5 and 7 are already set to ON at the time of shipment.)	ON OFF 1 2 3 4 5 6 7 8 Set No. 1 and No. 8 to ON. (No. 5 and 7 are already set to ON at the time of shipment.)

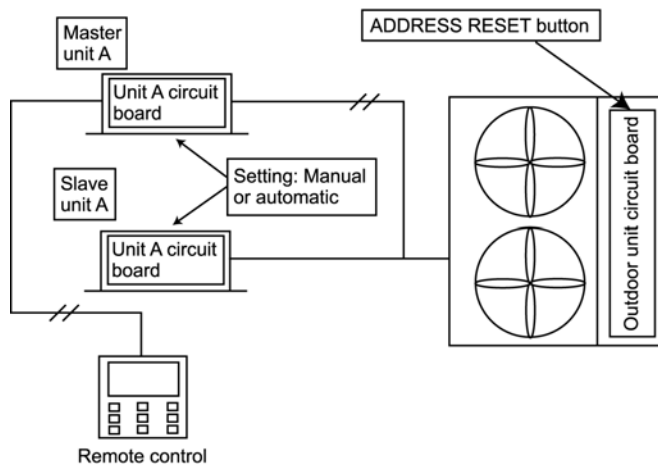

Master unit A Slave unit A

Master and slave unit setting should basically be carried out automatically.

- Setting occurs when the power is turned on.
(When power for indoor and outdoor units are turned on.)
- Remote control is connected to the master unit.
- Self-diagnosis displays are possible for slave units.
- If setting errors occur because of procedural mistakes or power supply quality problems, the ADDRESS RESET button function can be used.

19.1.2. Automatic address setting for twin and triple systems

Procedure: Turn on the power supply for the indoor and outdoor units.

Operation: Automatic address setting will start 10 to 30 seconds after the power supply is turned on, and will be completed after about 1 minute.

If the power supplies for the indoor unit and outdoor unit cannot be turned on at the same time, turn on the power supply for the outdoor unit, the indoor unit which is connected to the remote control, and then the other indoor units in that order.

If the order of turning on the power supply is incorrect, the master unit setting may overlap. In such a case, turn on the power supplies for all units in the correct order as given above, or carry out a twin/triple automatic address reset (press dip switch 3 on the outdoor unit continuously for 4 seconds or longer).

- The indoor unit which is connected to the remote control will have priority for becoming the master unit.
- The master unit thermostat will be used as the indoor temperature thermostat. If the master unit thermostat is turned on, the slave unit thermostats cannot be adjusted even if they happen to be on.
- If address setting using the DIP switches is carried out after automatic address setting has been carried out, use DIP switch No. 3 (SW3) on the outdoor unit to carry out automatic address resetting.
- If you would like to designate a particular indoor unit as the master unit because no master unit has been set, use the DIP switches on the slave units to make setting.

If automatic address setting is carried out once and then the slave unit address are set, the address will then be stored inside the EEPROM. Thus it is not necessary to repeat automatic address setting if the power is turned off and back on again.

19.1.3. DIP switch settings for twin/triple slave unit addresses

Procedure: Turn off the power supply, and then set DIP switch 1-8 to ON.
The unit will become slave unit 1.
(Set DIP switches 1-1 and 1-8 both to ON.)
The unit will become slave unit 2.)

Operation: Turn on the power supply.
The unit will operate as slave unit 1.
Automatic address setting is not carried out at this time.

If the setting is made while the power is still turned on, it is easier to mis-combine the setting with group settings. So, the setting should be made while the power is turned off.

- Only slave unit addresses can be set in this way. Master unit setting is not possible.
- If you make the DIP switch settings after the power has been turned on, carry out twin/triple automatic address resetting.
- Be sure to set DIP switch 1-8 to ON when setting twin/triple addresses. If DIP switch 1-1 is set to ON without setting 1-8 to ON, group addresses will be set instead, and the remote control open circuit error code (F26) will be displayed.

19.1.4. Automatic address resetting for twin/triple systems

Function: This reset the current twin/triple addresses which have been set automatically, and result in the reoccurrence of automatic twin/triple address settings.

Procedure: Press the ADDRESS RESET button SW3 (push button switch) on the outdoor unit circuit board continuously until LEDs 2 to 8 on the outdoor unit circuit board are all illuminated (takes approximately 3.5 seconds).

Operations: The outdoor unit will reset the addresses for the indoor units which it is connected to, and will send an instruction to carry out automatic address setting again. If the indoor unit DIP switch have not been manually set for twin/triple address setting, the indoor units receive this command and clear their existing settings and carry out automatic address setting.

If an indoor unit has had its address set by the DIP switch (DIP switch 1-8 is ON), or if the remote control unit is connected to one of the indoor unit, then the addresses for those indoor units cannot be reset.

- The indoor units will not run for approximately 1 minute while automatic twin/triple address resetting is being carried out.

- Do not turn off the power supply for at least 1 minute after automatic twin/triple address resetting has been carried out.

19.2. Piping connections

- The following table shows the pipe diameters for a twin-type system.

Outdoor unit main pipe diameter (mm)				Indoor unit combinations			
Liquid side: Gas side:	3HP ø 9.52 ø 15.88	Indoor unit capacity (HP)		1.5	1.5		
		Branch pipe diameter	Liquid side	ø 6.35	ø 6.35		
			Gas side	ø 12.7	ø 12.7		
Liquid side: Gas side:	4HP ø 9.52 ø 19.05	Indoor unit capacity (HP)		2.0	2.0	1.5	2.5
		Branch pipe diameter	Liquid side	ø 6.35	ø 6.35	ø 6.35	ø 6.35
			Gas side	ø 12.7	ø 12.7	ø 12.7	ø 15.88
Liquid side: Gas side:	5HP ø 9.52 ø 19.05	Indoor unit capacity (HP)		2.5	2.5	2.0	3.0
		Branch pipe diameter	Liquid side	ø 6.35	ø 6.35	ø 6.35	ø 9.52
			Gas side	ø 15.88	ø 15.88	ø 12.7	ø 15.88
Liquid side: Gas side:	6HP ø 9.52 ø 19.05	Indoor unit capacity (HP)		3.0	3.0	2.0	4.0
		Branch pipe diameter	Liquid side	ø 9.52	ø 9.52	ø 6.35	ø 9.52
			Gas side	ø 15.88	ø 15.88	ø 12.7	ø 19.05

- The following table shows the pipe diameters for a triple-type system.

Outdoor unit main pipe diameter (mm)				Indoor unit combinations					
Liquid side: Gas side:	6HP ø 9.52 ø 19.05	Indoor unit capacity (HP)		2.0	2.0	2.0	1.5	1.5	3.0
		Branch pipe diameter	Liquid side	ø 6.35	ø 6.35	ø 6.35	ø 6.35	ø 6.35	ø 9.52
			Gas side	ø 12.7	ø 12.7	ø 12.7	ø 12.7	ø 12.7	ø 15.88

- The following table shows the equivalent pipe lengths and height differences for twin- and triple-type systems.

Equivalent length	L + la + lb + lc				Within 50 m	
Branch pipe diameter	la, lb, (lc)				Within 15 m	
Branch pipe difference	la - lb, lb - (lc), la - (lc)				Within 10 m	
Height difference	H1	Within 30 m	Height difference between indoor units		H2	Within 1 m

Note:

1. Use the main pipe to gain any rise or fall required for the pipes.
2. The number of bends should be 8 or less in a single system (L + la, L + lb, L + lc), and 15 or less overall.
3. Branch pipes should be position horizontally.

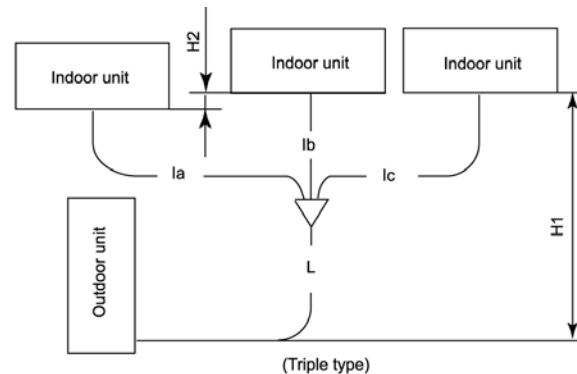
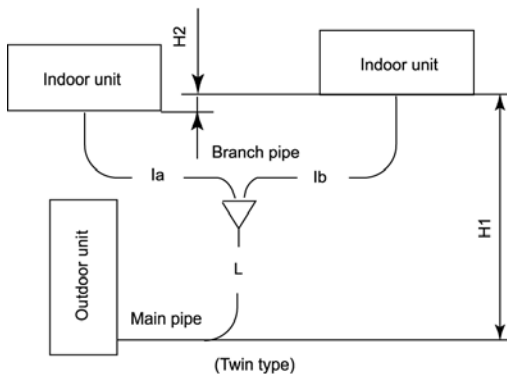

- The branch pipe should be horizontal to or perpendicular to the indoor unit.

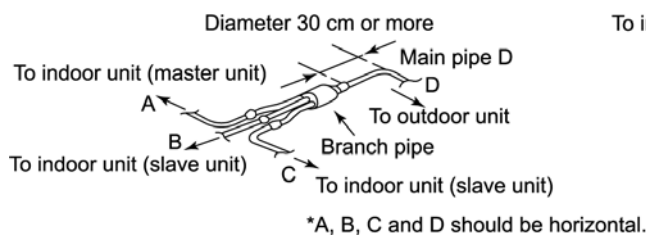

Horizontal connection

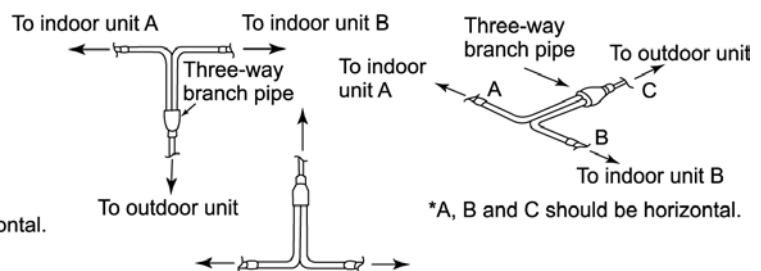

Vertical installation

Horizontal installation

19.3. Refrigerant charging

- For twin and triple-type systems

The pipe length is the total of the branch pipe (L) and the junction pipes (la → lb → lc in order from the thickest diameter). At the point where the pipe length exceeds 30 m, determine the amount of refrigerant for the remaining liquid-side pipe diameters and pipe lengths from the following table in order to charge the system.

Liquid-side pipe diameter	ø6.35	ø9.52
Additional charging amount (kg/m)	0.02	0.05

Example 1: For 50BB outdoor unit with an equivalent pipe length of 50 m

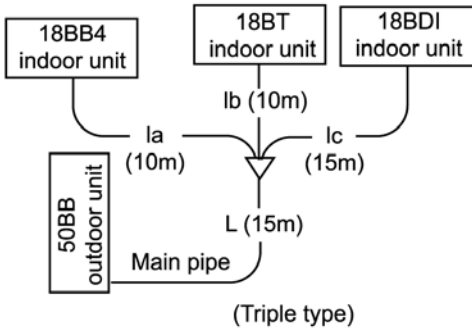

	Liquid pipe diameter	Equivalent length	Additional charging amount for each pipe (kg)	
Main pipe (L)	ø9.52	15m	Not needed if within 30m	
Main pipe	(la)	ø6.35	10m	Not needed if within 30m
	(lb)	ø6.35	10m	If exceeds 30m, 5m × 0.02 = 0.1
	(lc)	ø6.35	15m	15m × 0.02 = 0.3
—		50m	Total 0.4 kg	

Example 2: For 50BB outdoor unit with an equivalent pipe length of 40 m

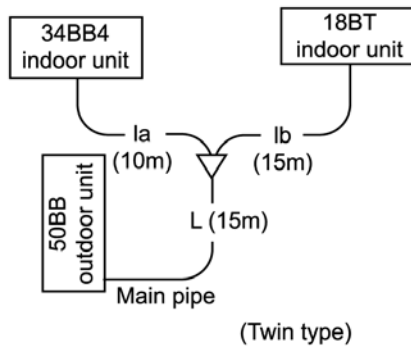

	Liquid pipe diameter	Equivalent length	Additional charging amount for each pipe (kg)	
Main pipe (L)	ø9.52	15m	Not needed if within 30m	
Main pipe	(la)	ø9.52	10m	Not needed if within 30m
	(lb)	ø6.35	15m	If exceeds 30m, 10m × 0.02 = 0.2
—		40m	Total 0.2 kg	

19.4. Wiring

Connection 1:

When only the outdoor unit draws power

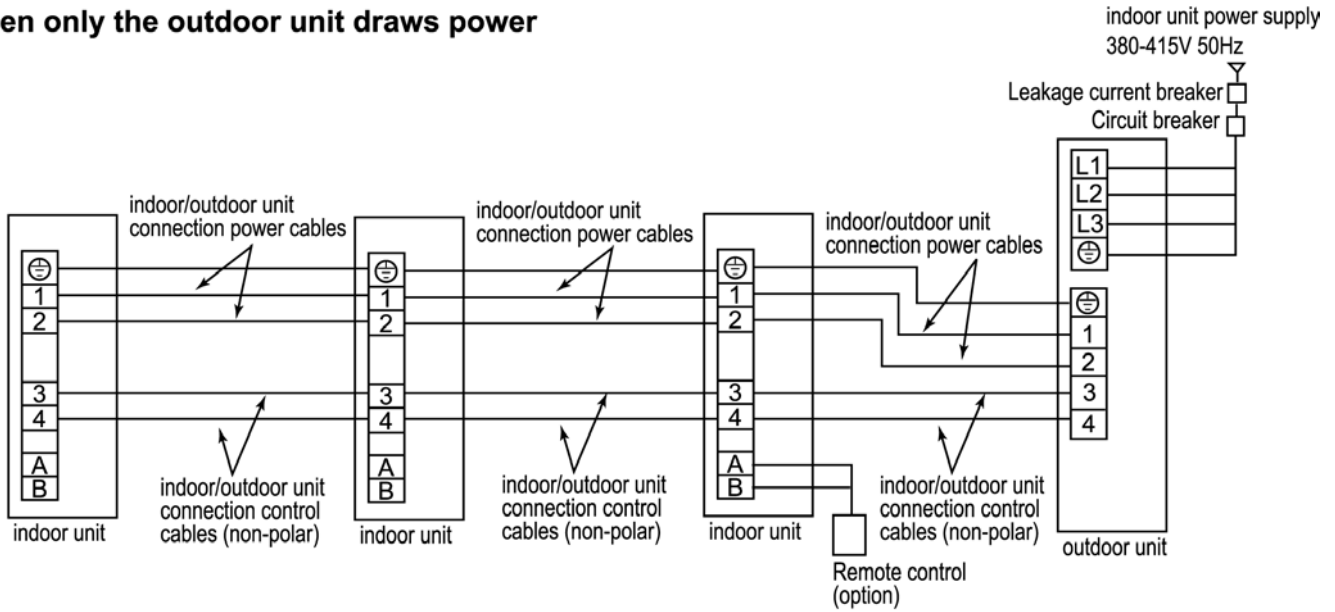

Connection 2:

When both indoor and outdoor unit draw power
(Example: 3 Phase power supply model)

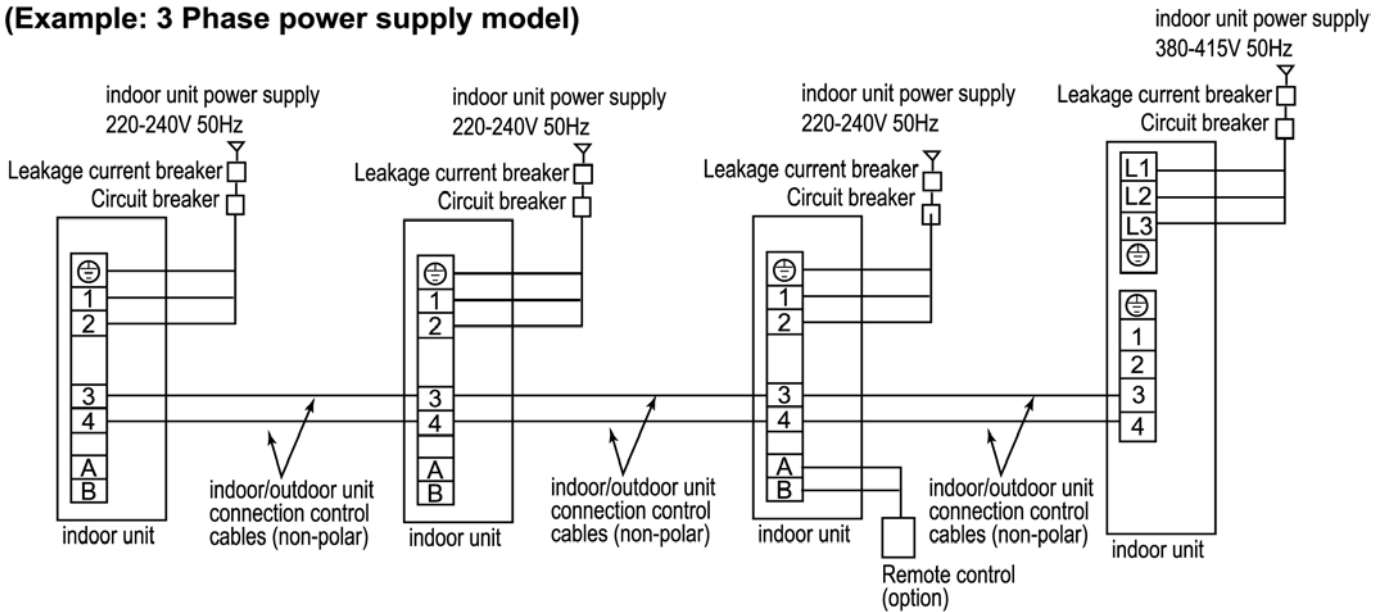

Important

* For the above connection 2, if outdoor terminal 1 & terminal 2 are joined to indoor terminal 3 & terminal 4 by mistake upon operation, the control circuit board will be defected. (Wiring mistake prevention is not applicable for this connection).

20 WIRING MISTAKE PREVENTION

Improved quality of installation work through adoption of an “Connection error prevention” circuit which prevents wiring mistakes

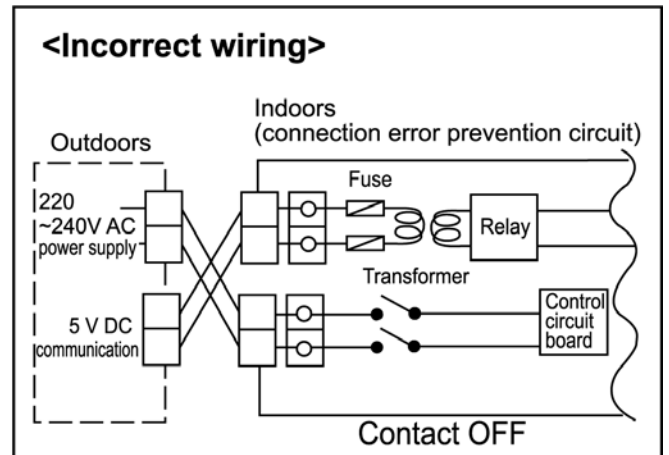
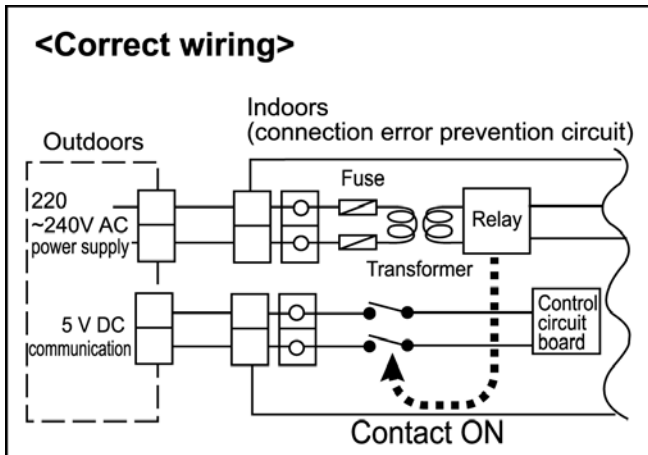

Connection errors with the control wires and the power supply wires will not only contribute to burning-out of the control circuit board, but can also cause large-scale working losses and affect reliability. If a circuit board with a “Connection error prevention” circuit is used, the relay will not operate if the wires have been connected incorrectly, so that current will not flow to the control circuit board. This is designed principally to compensate human error during installation.

Prevention of connection errors

These units are equipped with connection error prevention circuits. If the units do not operate, it is possible that the connection error prevention circuits have been operated. In such cases, check that the power supply wires (connected to terminals 1 and 2) and the control wires (connected to terminals 3 and 4) are connected correctly. If they are connected incorrectly, connect them correctly. Normal operation should then commence.

(CORRECT)

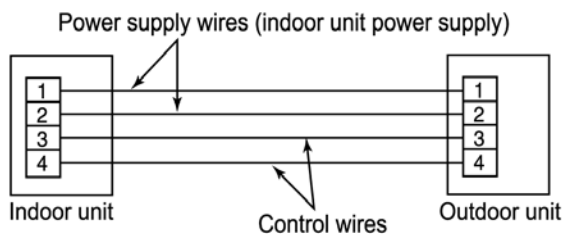

(INCORRECT)

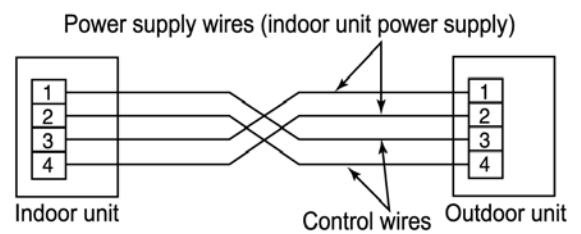

- Do not short the remote control wires to each other. (The protection circuit will be activated and the units will not operate.) Once the cause of the short is eliminated, normal operation will then be possible.

NOTE:

- Wait one minute after turning on the indoor unit power supply before operating the remote control.
- If nothing at all appears in the remote control LCD, check the power supply for the indoor unit. Refer to “TROUBLESHOOTING” chapter.

NOTE:

Do not allow any of the following connection, as such connection may damage the printed circuit board.

- Do not connect anything except a relay to the timer input or fan speed output (connector CNT1 on printed circuit board).
- Do not connect U-NET transmission wires to terminals 3 and 4 of the indoor and outdoor units. (*1)
- Do not connect U-NET transmission wires to terminals A and B of the remote control.

(*1) U-NET transmission wires are the communication wires used for the central control.

21 TEST OPERATION AND SELF DIAGNOSIS

21.1. Test operation

- Always use a properly-insulated tool to operate the switch on the circuit board. (Do not use your finger or any metallic object).
- Never turn on the power supply until all installation work has been completed.
- Turn on the circuit breaker before test operation extends past 12 hours. (The crankcase heater will be energized, which will warm the compressor and prevent liquid compression.)
- For three-phase models, check that the phase is not reversed. (If the phase is reversed, the LED on the printed circuit board will flash.)
- Check that the voltage is 198 V or higher when starting the unit. (The unit will not operate if the voltage is less than 198V.)
- Carry out test operation for 5 minutes or more, using the remote control or the switch on the outdoor unit printed circuit board.
- Always carry out cooling operation first during test operation, even during the warm season. (If heating is carried out first, problems with operation of the compressor will result.)

21.2. Test operation from the outdoor unit

(Outdoor unit printed circuit board)

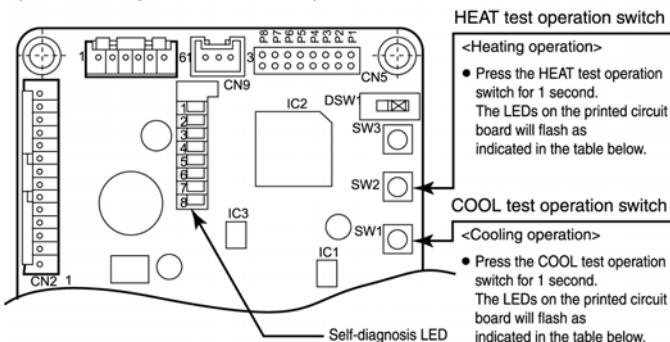

During outdoor unit emergency operation or test operation, the LEDs on the printed circuit board will flash.

	LEDs on outdoor unit printed circuit board						
	LED2	LED3	LED4	LED5	LED6	LED7	LED8
Emergency operation display			☀	☀	☀		
Cooling test operation from outdoor unit	☀	☀	☀				
Heating test operation from outdoor unit					☀	☀	☀

To cancel test operation, press the TEST RUN button once more while test operation is being carried out. (Test operation will stop automatically after 30 minutes have passed.)

21.3. Test operation using the wired remote control

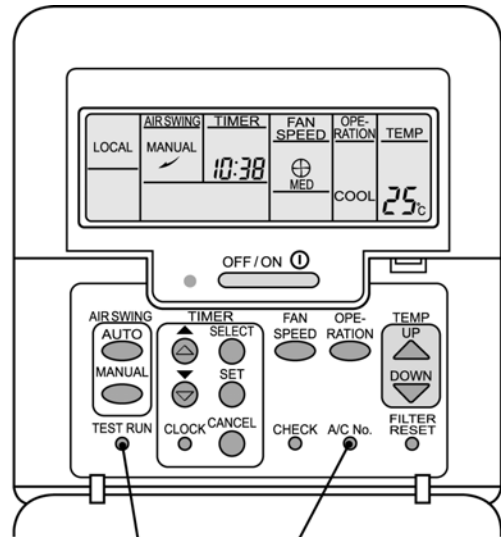

TEST RUN button

Air conditioner No. button

1. Check that "COOL" is displayed on the operation mode display, and then press the OFF/ON button to start test operation.
2. Within 1 minute of pressing the OFF/ON button, press the TEST RUN button.
3. The pipe temperature (gas pipe) will then be displayed in the temperature setting display of the remote control.

(Example)

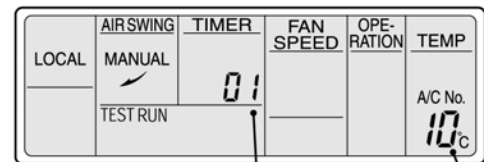

Air conditioner No. display

Pipe temperature display

- During group control, the number appearing in the timer display will change each time the air conditioner No. button is pressed, and the pipe temperature for the indoor unit corresponding to the number displayed will appear in the temperature setting display.
4. Check that the temperature in the pipe temperature display starts dropping after operation has been continuing for some time.

21.4. Test operation using the wireless remote control

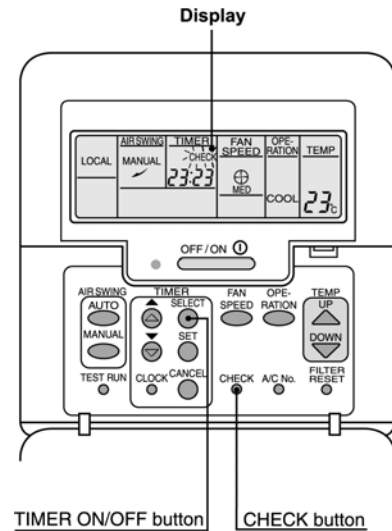
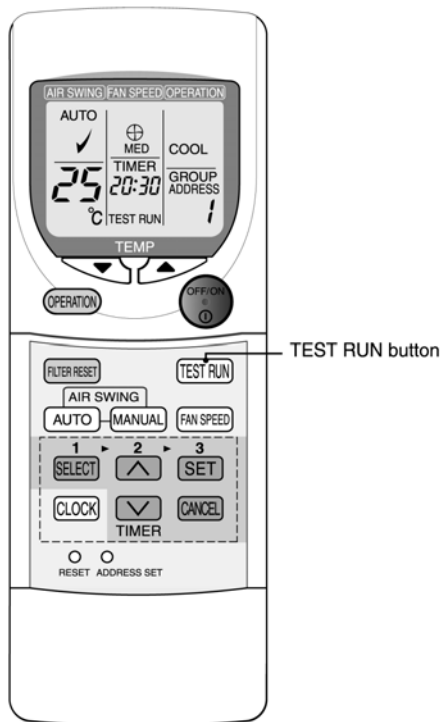

<Air conditioner No.>

- The air conditioner No. “01” appears during normal installation and use. When using group control, a different number may appear. The air conditioner No. can be displayed by pressing the air conditioner No. button.

(Example)

LOCAL	AIR SWING	TIMER	FAN SPEED	OPERATION	TEMP
	MANUAL	23:23		COOL	23°C

1. Within 1 minute of pressing the OFF/ON button, press to cooling operation and then press the TEST RUN button.

- If more than 1 minute passes, test operation cannot be started. In this case, press the OFF/ON button once more to repeat the operation.
- Use the OPERATION button to change the operation. The current operation mode will appear in the operation mode display.

2. When test operation starts, “TEST RUN” will appear in the timer display of the LCD, and operation will be carried out in accordance with the operation mode display (COOL or HEAT) appearing at that time. However, the number in the temperature setting display will not change.

(Cancelling test operation)

- Press the OFF/ON button, the TEMP (UP/DOWN) button, the OPERATION button, the FAN SPEED button or the TEST RUN button to cancel test operation.

21.5. Self-diagnosis function

- The wired remote control display and the self-diagnosis LEDs (red) on the outdoor unit printed circuit board indicate where the abnormality has occurred.
- Recalling the error display.

When an abnormality occurs at this unit, “CHECK” flashes in the display.

Press the CHECK button while the display is flashing.

(Example)

LOCAL	AIR SWING	TIMER	FAN SPEED	OPERATION	TEMP
		CHECK			A/C No. 01

The timer display will change and an error code from F15 to F49 will appear in place of the time. (The temperature setting display will also change to show the air conditioner No.)

Press the TIMER SELECT/SET button while the error is displayed.

(Example)

LOCAL	AIR SWING	TIMER	FAN SPEED	OPERATION	TEMP
		CHECK			A/C No. 01

The F15 - F49 display will change to the detail display.

- After checking the error display and the detail display, refer to the self-diagnosis error code table on the following page and check the location of the problem.
- If the problem is repaired and operation returns to normal, the CHECK display on the remote control will be eliminated, but the self-diagnosis LED will remain illuminated until the operation starts again.

How to display the past error message

If the "CHECK" display on the wired remote control is not flashing, press the CHECK button continuously for 5 seconds or more to display the problem details for the last problem or the problem before that. You can then switch between the displays for the previous problem and the problem before that by pressing the TIMER FORWARD or BACK buttons.

(Last problem display: 1F15 - 1F49)

Second-last problem display: 2F15 - 2F49)

Press the CHECK button once more to return to the normal display.

(Example of last problem display)

LOCAL	AIRSWING	TIMER CHECK	FAN SPEED	OPERATION	TEMP
		1F 15			A/C No. 01°C

An error code from 1F15 to 1F49 will be displayed.

(The temperature setting display will also change to show the air conditioner No.)

(Example)

LOCAL	AIRSWING	TIMER CHECK	FAN SPEED	OPERATION	TEMP
		1-01			A/C No. 01°C

If the TIMER SELECT/SET button is pressed while the error code from 1F15 to 1F49 is being displayed, the display screen will change to show the details of the last problem display.

(If 2F15 to 2F49 is being displayed, the details of the second-last problem display will appear.)

● Self-diagnosis error code table

☀: Flashing O: Illuminated Blank: Off

Remote control display			Printed circuit board self-diagnosis LED (red)								Error display	
Wired		Wireless	Indoor unit	Outdoor unit							(Check location)	
Error display	Detail display	Operation LED	LED2	LED2	LED3	LED4	LED5	LED6	LED7	LED8		
F15	-01	☀	☀	☀					☀	(※2)	(※2)	Drain level float switch problem Drain pump and drain pipe, indoor unit connectors CN6 & CN10, or relay connector
F16	-01	☀	☀		☀				☀	(※2)	(※2)	Louvre switch problem Louvre motor, veneer panel connection terminal, or indoor unit connectors CN1 & CN6
F17	-01	☀	☀	☀	☀				☀	(※2)	(※2)	Option problem Option connection terminals
F20	-01	☀	☀	☀				☀		(※2)	(※2)	Indoor temperature thermistor problem Indoor temperature thermistor lead wire or indoor unit connector CN1
	-02	☀	☀	☀		☀	☀			(※2)	(※2)	Remote control thermistor problem Remote control thermistor
F21	-01	☀	☀		☀		☀			(※2)	(※2)	Pipe temperature thermistor problem (indoor unit side) Pipe temperature thermistor lead wire or indoor unit connector CN1
F25	-01	☀	☀			☀				(※2)	(※2)	Centralised control address overlap problem Check settings for optional centralised control circuit board address switch
F26	-01	☀	☀		☀					(※2)	(※2)	Remote control transmission wire open circuit problem Remote control unit cable and connection terminals
	-02	☀	☀	☀						(※2)	(※2)	Remote control transmission problem Check the transmission wave pattern
F27	-01	☀	☀		☀				☀			Indoor/outdoor unit transmission wire open circuit problem Indoor/outdoor unit connection cable and connection terminals, or indoor unit and outdoor unit power supplies
	-02	☀	☀	☀					☀			Indoor/outdoor unit transmission problem Check the transmission wave pattern
F29	-01	☀	☀		☀		☀	☀	(※2)	(※2)		Indoor unit setting problem Abnormal setting of the indoor p.c. board
	-02	☀	☀	☀			☀	☀	(※2)	(※2)		Indoor unit setting problem Abnormal setting of the indoor p.c. board
	-12	☀	☀	☀		☀	☀	☀	(※2)	(※2)		Remote control unit setting problem Abnormal setting of the remote control
F30	-02	☀	☀	☀		☀		☀	☀			Negative or open phase power supply Check the main power supply terminal board connections, and switch the main power supply phase
	-06	☀	☀		☀	☀		☀	☀			Poor power supply connection, or distorted voltage wave pattern Check the main power supply terminal board connections, and check the power supply wave pattern.
	-07	☀	☀	☀	☀	☀		☀	☀			Poor power supply connection Check the main power supply terminal board connections
F31	-02	☀	☀		☀			☀	☀			High-pressure cut-off Refrigeration system, Obstructing of the heat radiation from outdoor unit
F33	-01	☀	☀	☀					☀	☀		Compressor overcurrent protection Open phase or lock in compressor, or blown main power supply fuse
	-02	☀	☀	☀	☀				☀	☀		Compressor discharge temperature protection Insufficient gas
F40	-41	☀	☀	☀				☀		☀		Compressor discharge temperature thermistor problem Discharge temperature thermistor lead wire, outdoor unit connector CN2, or relay connector
	-61	☀	☀		☀			☀		☀		Heat exchanger outlet temperature thermistor problem (Outdoor unit) Heat exchanger outlet temperature thermistor lead wire, outdoor unit connector CN2, or relay connector
F41	-02	☀	☀	☀		☀	☀		☀			High-pressure switch open circuit problem High-pressure switch lead wire, outdoor unit connector CN2, or relay connector
	-03	☀	☀		☀	☀	☀		☀			Heating pressure switch open circuit problem Heating pressure switch lead wire, outdoor unit connector CN2, or relay connector
F42	-01	☀	☀	☀	☀			☀		☀		Current detector open circuit or compressor current problem Outdoor unit connector CN2, compressor internal protection system activated, or blown main power supply fuse
F49	-01	☀	☀		☀			☀	☀	☀		Outdoor unit setting problem Abnormal setting of the outdoor p.c. board
F49	-01	☀	☀	☀				☀	☀	☀		Outdoor unit setting problem Abnormal setting of the outdoor p.c. board

If more than one error occurs between the indoor and outdoor units, the problem display on the remote controller may not match the LED display on the outdoor unit printed circuit board. In such cases, check both locations and remove the causes of the problems.

	LED7	LED8	Unit display for twin/triple system
(※2)			Master unit error
	O		Slave unit 1 error
		O	Slave unit 2 error

● The LED1 (green) illuminates to indicate that the microprocessor on the microprocessor circuit board is operating normally. If the LED is switched off or is flashing irregularly, check the power supply, and turn it off and then on again.

22 SETTING OF SAVE ENERGY AND THERMISTOR SWITCH

22.1. Energy save setting

- Upper and lower limit can be set for the setting temperature during cooling and heating operation. (The factory shipment setting has an upper limit of 31°C and a lower limit of 16°C.)

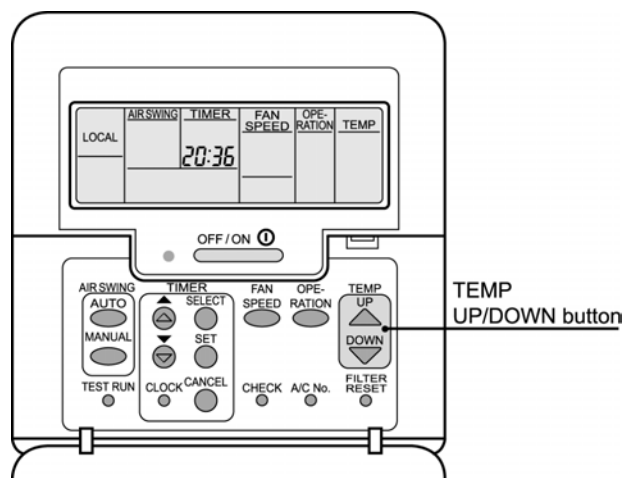

1. While operation is stopped, press the TEMP UP and TEMP DOWN buttons simultaneously.



The display will change.

(Example)

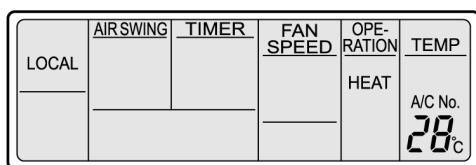

2. To set an upper limit

Press the OPERATION button until HEAT is displayed.

↓

Press the TEMP UP or TEMP DOWN button to set the temperature.

↓

Press the SET button to complete the upper limit setting.

Example:

If the heating display is set to 28°C, setting the temperature to higher than 28°C will not be possible.

* Upper and lower limits cannot be set at the same time.

3. To set a lower limit

Press the OPERATION button until COOL is displayed.

↓

Press the TEMP UP or TEMP DOWN button to set the temperature.

↓

Press the SET button to complete the lower limit setting.

Example:

If the cooling display is set to 22°C, setting the temperature to lower than 22°C will not be possible.

* Press the CANCEL button to cancel the setting.

22.2. Switching to the remote control thermistor

- The temperature detection thermistor used for detecting the indoor temperature can be switched between the thermistor at the indoor unit and the thermistor at the remote control unit. (The factory shipment setting is at the indoor unit side.)

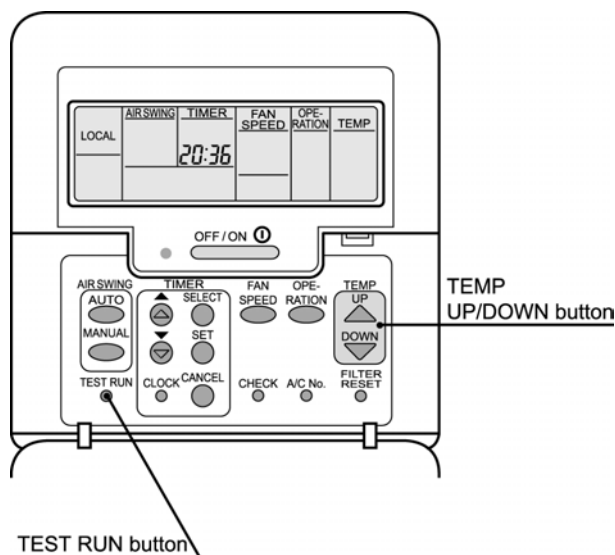

1. While operation is stopped, press and hold the TEST RUN button, TEMP UP button and TEMP DOWN button simultaneously.



The time display on the timer display panel will change.

(Example)

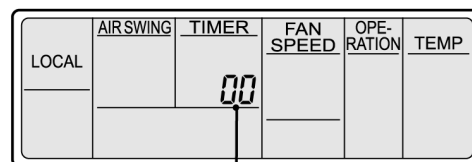

"00" ... Indoor unit temperature detection setting
 "01" ... Remote control temperature detection setting

Press the FORWARD or BACK timer button to change the temperature detection setting.

2. Press the SET button to complete the setting.

To change the setting, repeat the above operation.

23 GROUP CONTROL

Setting group for 1 remote control unit

- When using a remote control thermostat, the thermostat setting is used for all indoor units in the group.
- During group control, up to a maximum of 16 indoor units can be connected. (Do not mix heat pump units and cooling-only units.)
- Do not mix manual settings and automatic settings. (Manual settings take priority.)
- The master unit and slave units can be centralized controlled during group control.

Automatic setting for group control

- If the power supplies for indoor units which are connected are turned on simultaneously, the indoor unit numbers will

be determined automatically after approximately 1 minute. (DIP switch settings are not necessary.)

NOTE:

- Correct wiring connections are a basic requirement for automatic setting. If the wires are connected incorrectly when the power is turned on, the settings will not be made correctly and operation will not be possible.
- When address numbers are set automatically, you will not know which address number corresponds to which indoor unit.
- Do not turn off the power supply for at least 1 minute during automatic address setting, otherwise the settings will not be made correctly.

(Manual setting for group control)

Manual Setting	Indoor unit No.	1	2	3	4	5	6	7	8	
	DIP switch (DSW1)	OFF ON	OFF ON	OFF ON	OFF ON	OFF ON	OFF ON	OFF ON	OFF ON	OFF ON
	Setting on Indoor unit Printed circuit Board Air conditioner No.setting	No operation necessary	1 is ON	2 is ON	1 and 2 are ON	3 is ON	1 and 3 are ON	2 and 3 are ON	1, 2 and 3 are ON	
Indoor unit No.	9	10	11	12	13	14	15	16		
DIP switch (DSW1)	OFF ON	OFF ON	OFF ON	OFF ON	OFF ON	OFF ON	OFF ON	OFF ON	OFF ON	
Setting on Indoor unit Printed circuit Board Air conditioner No.setting	4 is ON	1 and 4 are ON	2 and 4 are ON	1, 2 and 4 are ON	3 and 4 are ON	1, 3 and 4 are ON	2, 3 and 4 are ON	1, 2, 3, 4 are ON		

Automatic address resetting for group control

Set the DIP switches 1 to 4 to OFF and stop the operation. Then press the "AIR SWING AUTO" "OPERATION" and "Air conditioner No." buttons simultaneously. Then addresses will be momentarily reset, and then automatic address setting will be carried out once more.

Note with regard to the Mini-cassette

When carrying out group control of a Mini-cassette system using a single wireless remote control, be sure to disconnect the connectors for all receptor circuit boards except the one for indoor unit. No. 1, before turning on the power. (The same action as for the slave units in twin and triple systems is necessary.)

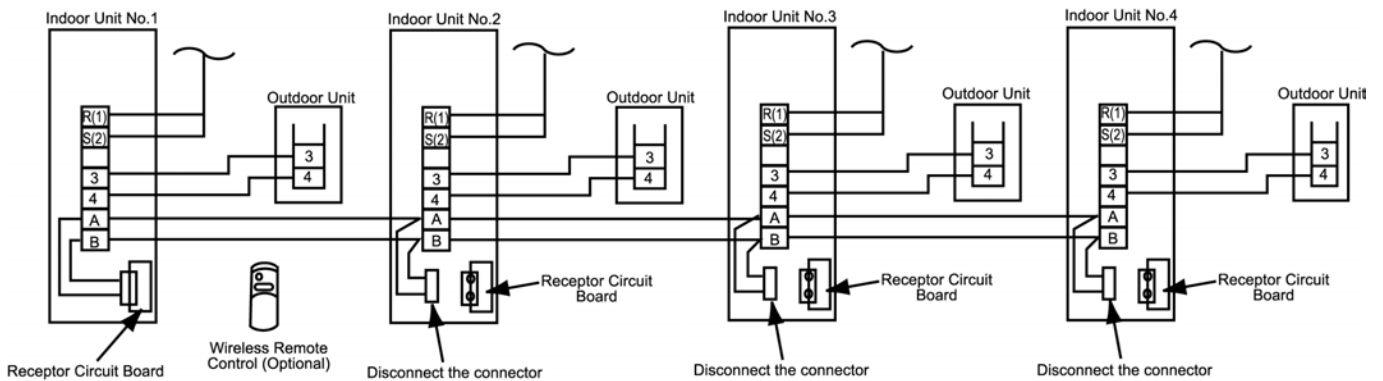

24 TROUBLESHOOTING

If test operation does not proceed correctly

Carry out test operation after approximately 12 hours have passed since the power was turned on (crankcase heater is energized). If operation is started by using the remote control within 1 minute of turning on the power, the outdoor unit settings will not be made correctly and correct operation will not be possible.

If the following symptoms occur after turning on the power, check the wiring connections once more.

● **For standard installation**
(System example)

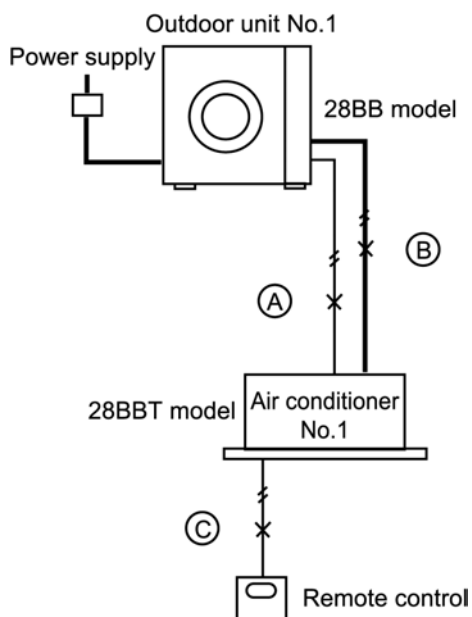

1. The main power is turned on while the indoor-outdoor transmission wires are not connected (open circuit at section A)

Symptom:

Remote control unit... "CHECK" flashes

NOTE:

Indoor unit... LED2 on printed circuit board flashes
Outdoor unit... LED3 and LED7 on printed circuit board flash

2. The main power is turned on while the indoor-outdoor power supply wires are not connected (open circuit at section B)

Symptom:

Remote control unit... Display of "No power supply"

NOTE:

Indoor unit... No display
Outdoor unit... LED3 and LED7 on printed circuit board flash

3. The main power is turned on while the remote control unit connection cord is not connected (open circuit at section C)

Symptom:

Remote control unit... Display of "No power supply"

NOTE:

Indoor unit... LED1 on printed circuit board stays illuminated

Outdoor unit... LED1 on printed circuit board stays illuminated

(When remote control display shows "Power supply")

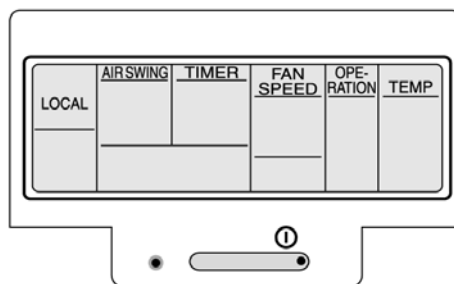

(When remote control display shows "No power supply")

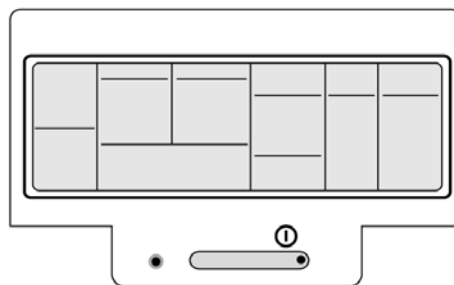

Remedy

1. Turn off the main power.
↓
2. Connect the disconnected wire correctly.
↓
3. Turn on the main power.
↓
4. After 1 minute, start the operation using the remote control.
(Indoor unit operation will start according to the remote control setting.)
(Outdoor unit operation will start after 3-5 minutes.)

NOTE:

The "CHECK" display on the remote control and the flashing of LEDs on the printed circuit boards will not occur immediately. They will appear 3-6 minutes after the main power is turned on.

● **During twin/triple operation**
(System example)

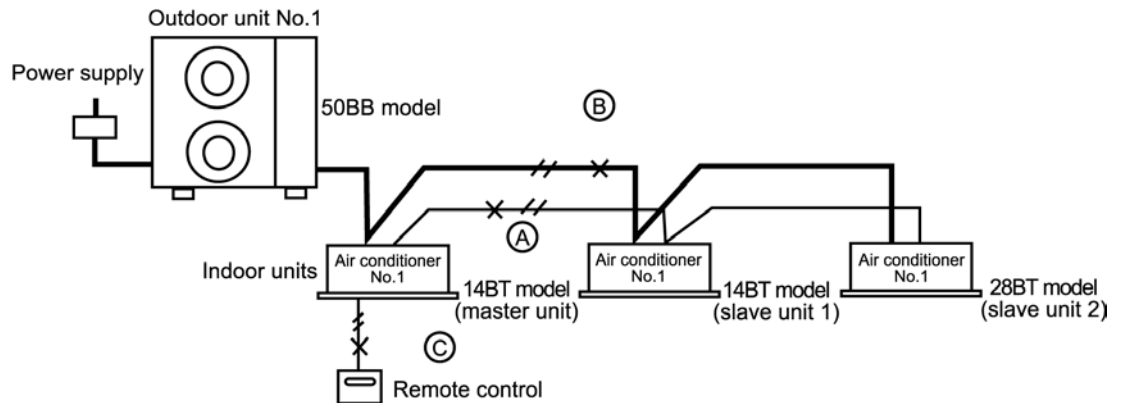

1. The main power is turned on while the transmission wires between the indoor unit(s) are not connected (open circuit at section A)

Symptom:

Nothing abnormal appears on the remote control display. If operation is started in this condition, the combination of the 50BB outdoor unit and the 14BB4 indoor unit (master unit) will result in abnormal operation.

↓

If operation continues, an abnormality will occur on the refrigeration cycle and operation will stop.

- Remote control... "CHECK" flashes
- Indoor unit (master)... The LEDs on the printed circuit board flash and operation stops
- Indoor unit (slave)... LED1 on the printed circuit board illuminates and the unit does not operate at all
- Outdoor unit... The LEDs on the printed circuit board flash and operation stops

2. The main power is turned on while the power supply wires between the indoor unit(s) are not connected (open circuit at section B)

Symptom:

Same as above. If operation continues, an abnormality will occur on the refrigeration cycle and operation will stop.

↓

- Remote control... "CHECK" flashes
- Indoor unit (master)... The LEDs on the printed circuit board flash
- Indoor unit (slave)... The LEDs on the printed circuit board do not illuminate and the unit does not operate at all
- Outdoor unit... The LEDs on the printed circuit board flash and operation stops

3. The main power is turned on while the remote control

connection cord is not connected (open circuit at section C)

Symptom:

- Remote control unit... Display of "No power supply"
- Indoor unit (master)... LED1 on the printed circuit board stays illuminated and the unit does not operate
- Indoor unit (slave)... LED1 on the printed circuit board stays illuminated and the unit does not operate
- Outdoor unit... LED1 on the printed circuit board stays illuminated and the unit does not operate

Remedy

1. Turn off the main power.
↓
2. Connect the disconnected wires correctly.
↓
3. Turn on the main power.
↓
4. After 1 minute, start the operation using the remote control.
(Indoor units' operation will start according to the remote control setting.)
(Outdoor unit operation will start after 3-5 minutes.)

If slave units do not operate even after the wiring has been corrected (automatic addressing is not possible)

1. Check that DIP switches 1 to 4 and DIP switch 8 are all set to OFF, and then stop operation.
↓
2. Press the ADDRESS RESET button (SW3) at the outdoor unit for approximately 4 seconds
(The self-diagnosis LEDs 2 to 8 will illuminate in order, and the system is reset once they are all illuminated.)

The above procedure cannot be used to carry out automatic address resetting during group control.

● **During group control operation**
(System example)

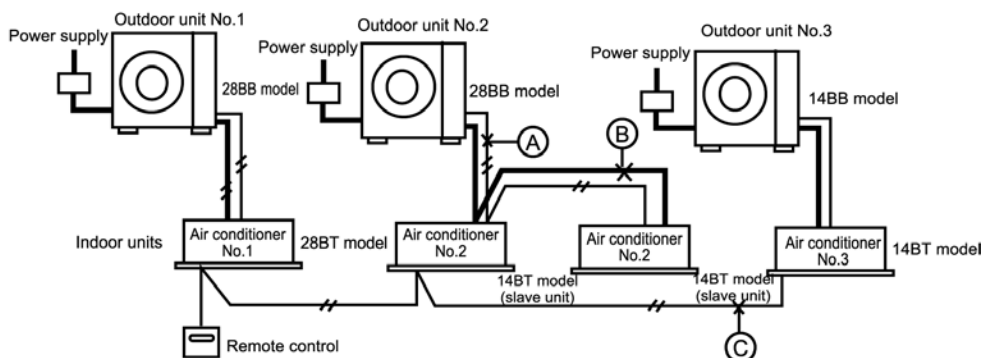

1. The main power is turned on while the transmission wires between the indoor unit and the outdoor unit are not connected (open circuit at section A)

Symptom:

Operation of indoor unit No. 1 and indoor unit No. 3 is possible.

However, "CHECK" flashes in the remote control display for 3-5 minutes after the main power is turned on.

- Remote control... "CHECK" flashes
- Indoor unit No. 2... LED2 on the printed circuit board flashes (both master and slave units)
- Outdoor unit No. 2... LED3 and LED7 on the printed circuit board flash

2. The main power is turned on while the power supply wires between the indoor units are not connected (open circuit at section B)

Symptom:

Operation of indoor unit No. 1 and indoor unit No. 3 is possible

However, if operation is then started in this condition, the combination of the 28BB outdoor unit and the 14BT indoor unit (master unit) will result in abnormal operation of indoor unit No. 2.

↓
If operation continues, an abnormality will occur on the refrigeration cycle and operation will stop

- Remote control... "CHECK" flashes (indoor unit No. 2 abnormality)
- Indoor unit No. 2... LED2 on the printed circuit board flashes (both master and slave units)
- Outdoor unit No. 2... The LEDs on the printed circuit board flash

3. The main power is turned on while the remote control connection cord is not connected (open circuit at section C)

Symptom:

Nothing abnormal appears on the remote control display, and operation of indoor unit No. 1 and indoor unit No. 2 is possible.

However, indoor unit No. 3 cannot be operated.

● **Remedy**

1. Turn off the main power.
↓
2. Connect the disconnected wires correctly.
↓
3. Turn on the main power.
↓
4. After 1 minute, start the operation using the remote control.
(Indoor units' operation will start according to the remote control setting.)
(Outdoor units' operation will start after 3-5 minutes.)

If slave units do not operate even after the wiring has been corrected (automatic addressing is not possible)

1. Check that DIP switches 1 to 4 and DIP switch 8 are all set to OFF, and then stop operation.
↓
2. Press the "AIR SWING AUTO", "OPERATION" and "A/C No." buttons simultaneously.
The addresses will be momentarily reset, and then automatic address setting will be carried out once more.

The above procedure cannot be used to carry out automatic address resetting of twin/triple control.

(Note on automatic address setting)

The printed circuit boards automatically store the connected system configuration when power is supplied. As a result, once the power has been turned on for these printed circuit boards, the units can not be changed about within the system, even if the units are of the same model and have same capacity.

● **Address setting for twin/triple system**
(Example)

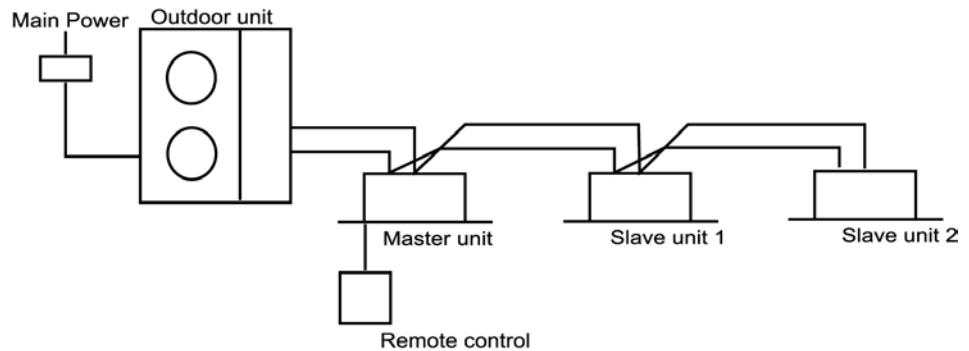

1. Automatic address setting (don't need to set dip-switch)
If the wiring is connected properly as above example, the address is set automatically by the main power supply. An indoor unit with remote control will be set as the master. If the power source is installed to indoor units and outdoor units separately, turn on the switch by following the procedure: outdoor unit, then indoor unit with control, and finally other indoor units.

When the slave units do not operate (when address cannot be set)

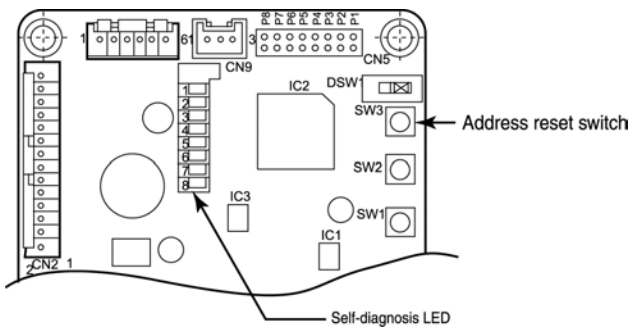

Reset the address by following the procedure:

- a. After making sure that dip-switches No. 1 to 4 and No. 8 are OFF, stop the operation.
- b. Push address reset button (SW3) on the outdoor unit PC board for 4 seconds. Self-diagnosis LED No. 2 to 8 will start blinking in order. And when all 7 pieces of LEDs (No. 2 ~ 8) are illuminated, the address for the slave unit has been reset.

Important: The address for the group control cannot be reset, using the above mentioned procedure.

2. Manual address setting (by dip-switch DSW1)

When setting the address manually, set the dip-switch of the PC board of the indoor unit as follows:

Master Unit	Slave unit (Slave No.1 of Triple)	Slave unit (Slave No.2 of Triple)
The unit with the wired remote control or the ray receiver connected will be the master unit.	DSW1 ON OFF No. 8 ON, The other no change	ON OFF No. 1 and 8 ON, The other no change

● **Address setting for group control system**
(Example)

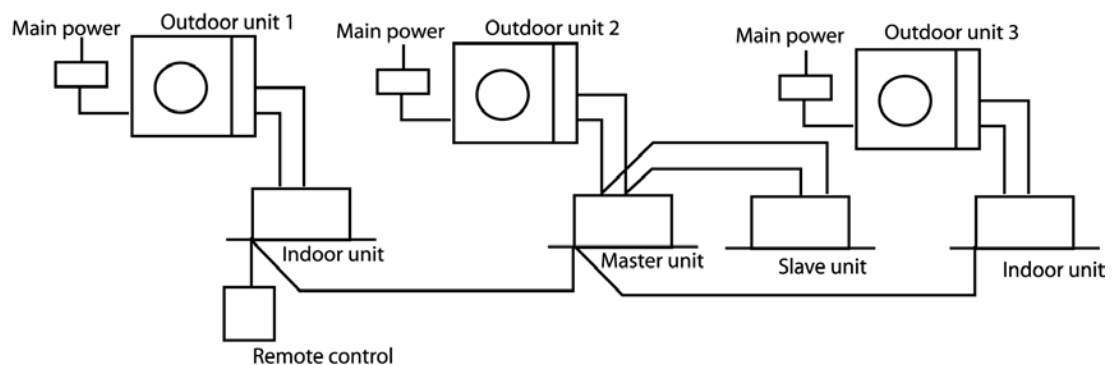

1. Automatic address setting (don't need to set dip-switch)
If the wiring is connected properly as above example, the AC numbers are set automatically by the main power supply. An indoor unit with remote control will be set as the master. If the power source is installed to indoor units and outdoor units separately, turn on the switch by following the

procedure: outdoor unit, then indoor unit with control, and finally other indoor units. The AC number will be set at random.

When the slave units do not operate (when address cannot be set)

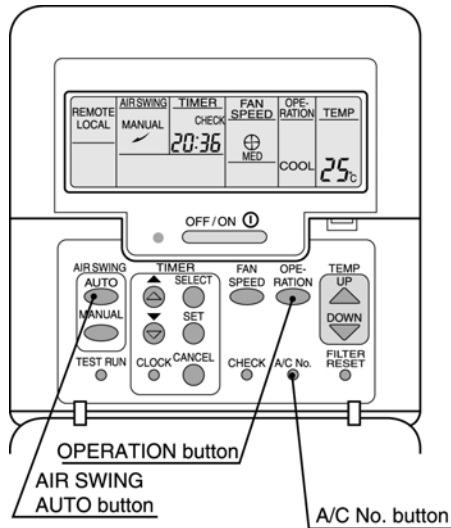

Reset the address by following the procedure:

- Make sure that dip-switches No. 1 to 4 and No. 8 are OFF, stop the operation.
- Simultaneously, push buttons "AIR SWING AUTO", "OPERATION" and "A/C No.". The address will be reset and new address will be set.

Important: The address for the Twin/Triple control cannot be reset, using the above mentioned procedure.

2. Manual address setting (by dip-switch DSW1)

When setting the address manually, set the dip-switch of the PC board of the indoor unit as follows:

Master Unit	Slave units		
	Slave No.1 of twin system (to outdoor unit 2)	Slave No.2 (to outdoor unit 3)	Slave No.3 (to outdoor unit 4)
The unit with the wired remote control or the ray receiver connected will be the master unit. (DSW1 of No.5 and 7 are defaulted to "ON").	<p>DSW1</p> <p>No. 1 ON, the others no change</p>	<p>DSW1</p> <p>No. 8 ON, the others no change</p>	<p>DSW1</p> <p>No. 2 ON, the others no change</p>

3. Manual address setting (by dip-switch DSW1)

When setting the address manually, set the dip-switch of the PC board in the indoor unit as follows:

Indoor unit No.	1	2	3	4	5	6	7	8
Dip-switch on the PCB of the indoor unit (DSW1)								
	No Change	No.1 ON	No.2 ON	No.1,2 ON	No.3 ON	No.1, 3 ON	No.2, 3 ON	No.1, 2, 3 ON
Indoor unit No.	9	10	11	12	13	14	15	16
Dip-switch on the PCB of the indoor unit (DSW1)								
	No.4 ON	No.1, 4 ON	No.2, 4 ON	No.1,2, 4 ON	No.3, 4 ON	No.1, 3, 4 ON	No.2, 3, 4 ON	No.1, 2, 3, 4 ON

Procedures of deleting memory for twin/triple control system

- Switch off the main power supply.
- Set the No. 8 pin of dip switch (DSW1) at the indoor unit's P.C. board to "ON" position.
- Switch on the main power supply for a minute and then turn it off.
- Set the No. 8 pin of dip switch (DSW1) to "OFF" position.

Procedures of deleting memory for group control system

- Switch off the main power supply.
- Set the No. 1 until No. 4 pin of dip switch (DSW1) at the indoor unit's P.C. board to "ON" position. (Make sure No. 8 pin of dip switch (DSW1) is at "OFF" position)
- Switch on the main power supply for a minute and then turn it off.
- Set the No. 1 pin until No. 4 pin of dip switch (DSW1) to "OFF" position.

(Important notice)

Above procedures are meant for deleting memory on indoor unit's P.C. board. And it is not for Address reset.

Indoor unit P.C. board layout

Below drawing shows the location of dip switch 1 (DSW1) on the indoor unit P.C. board.

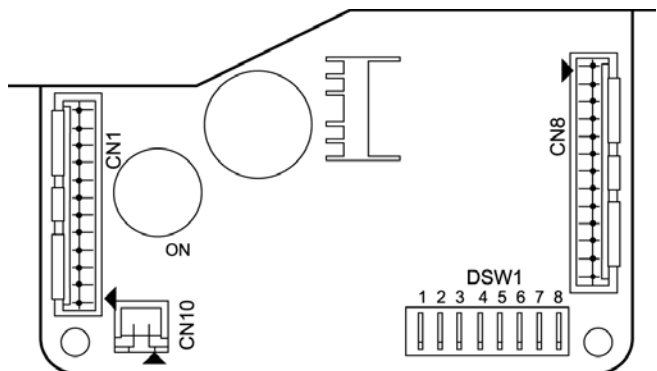

Dip switch 1 (DSW1). [to be used for manual setting]

25 EMERGENCY OPERATION

Emergency operation

- Emergency operation of outdoor unit
Emergency operation can be carried out by setting the DSW1 switch on the printed circuit board of the outdoor unit to the EMERGENCY position. However, emergency operation is only carried out when an abnormality is detected by the indoor/outdoor temperature thermistors. The resistance values of each thermistor are measured as shown in the table below to determine if there is an abnormality.

Thermistor resistance table

Temperature	Resistance value (kΩ) ± 5%	
	Room temperature thermistor	Pipe temperature thermistor
-20°C	205.8	197.8
-10°C	114.6	111.9
-5°C	87.3	85.4
0°C	67.0	65.8
5°C	51.8	51.0
10°C	40.4	39.9
15°C	31.7	30.7
20°C	25.1	25.0
25°C	20.0	20.0
30°C	16.1	16.0
40°C	10.4	10.6
50°C	6.9	7.1
60°C	4.7	4.9
70°C	----	3.5
80°C	----	2.5
90°C	----	1.8
100°C	----	1.4

The pipe temperature thermistor resistance value are the same for the indoor and outdoor units.

<When a thermistor abnormality is judged to have occurred>

- Set only the thermistor which shows an abnormality to the condition as shown in the table below to carry out emergency operation.

	Thermistor	Cooling mode	Heating mode
Indoor unit	Room temperature	Fixed at 25°C	
	Pipe temperature	Shorted	Open

	Thermistor	Cooling mode	Heating mode
Outdoor unit	Discharge temperature	Open	Shorted
	Heat exchanger outlet temperature	Shorted	Open

- Refer to the circuit diagram for the connection locations for each thermistor.
- If there is an abnormality in the room temperature thermistor, the temperature will be fixed at 25°C regardless of the remote control display.

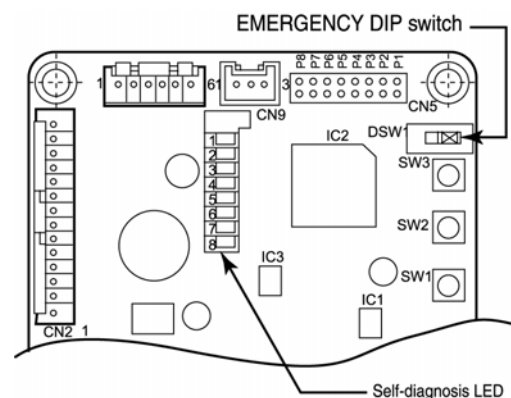

NOTE:

- Any abnormalities detected by the temperature thermistors are ignored during emergency operation, therefore, long-term operation in this mode should be avoided.
- After emergency mode operation has been completed and normal operation is to be resumed, turn off the power supplies for the indoor and outdoor units and set the DSW1 switch to NORMAL position.
- Self-diagnosis LEDs 4 to 6 will flash during emergency operation.

26 CONTROL

Description of basic Functions

26.1. Cooling mode operation time chart

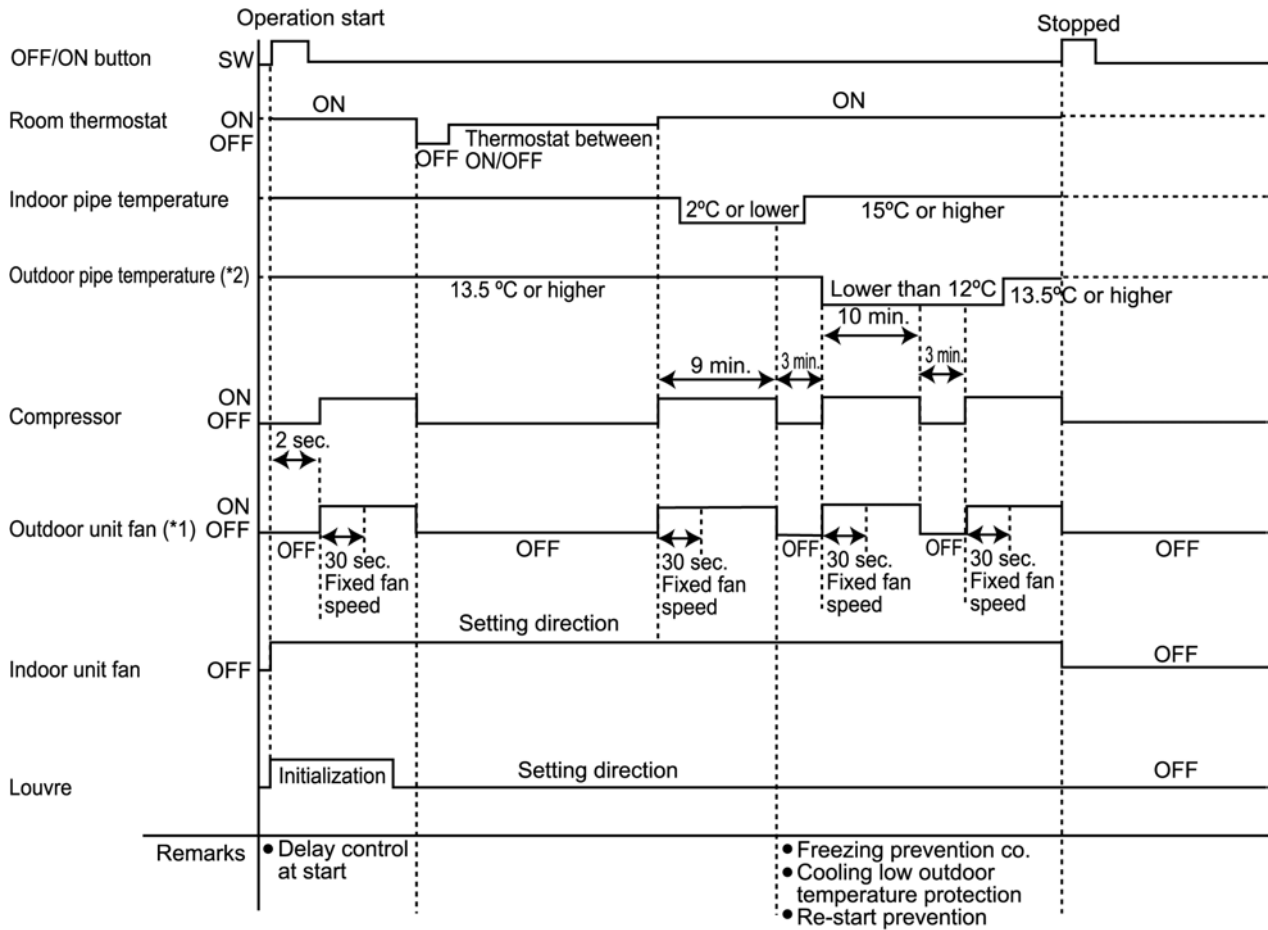

(*1)

Outdoor unit fan start control during cooling

At the start of cooling mode and drying mode operation, the outdoor unit heat exchanger outlet temperature is detected in order to set the fan speed.

Operation is carried out at the fan speed detected for 30 seconds.

Heat exchanger outlet temperature detected (T)	Outdoor unit fan start speed
$T < 0^{\circ}\text{C}$	SUPER LOW
$0^{\circ}\text{C} \leq T < 10^{\circ}\text{C}$	LOW
$10^{\circ}\text{C} \leq T < 20^{\circ}\text{C}$	MEDIUM
$20^{\circ}\text{C} \leq T < 25^{\circ}\text{C}$	HIGH
$25^{\circ}\text{C} \leq T$	SUPER HIGH

After 30 seconds, the heat exchanger outlet temperature is detected and the outdoor unit fan speed is changed automatically.

(*2)

Cooling low outdoor temperature protection

When the outlet temperature of the heat exchanger drops to less than 12°C for a continuous period of 10 minutes, the outdoor unit stops.

This is cancelled after 3 minutes (re-start prevention)

- Remote control displays and indoor unit operation continue during this time.
- The 10 minutes countdown is cleared if the compressor stops or if the temperature at the outdoor unit outlet rises to 13.5°C or higher.

26.2. Freezing prevention control

1. Operation

During cooling mode operation, after 9 minutes have passed since the compressor turned on, the outdoor unit will stop its operation when the temperature detected by the indoor unit pipe temperature sensor is 2°C or lower.

The indoor unit continues operating at the fan speed set by the remote control. (The remote control display does not change.)

2. Cancelling

This control is cancelled when the temperature detected by the indoor unit pipe temperature sensor is 15°C or higher, however 3 minutes waiting of prevention control is necessary.

(The 9 minutes countdown is cleared while the compressor is stopped.)

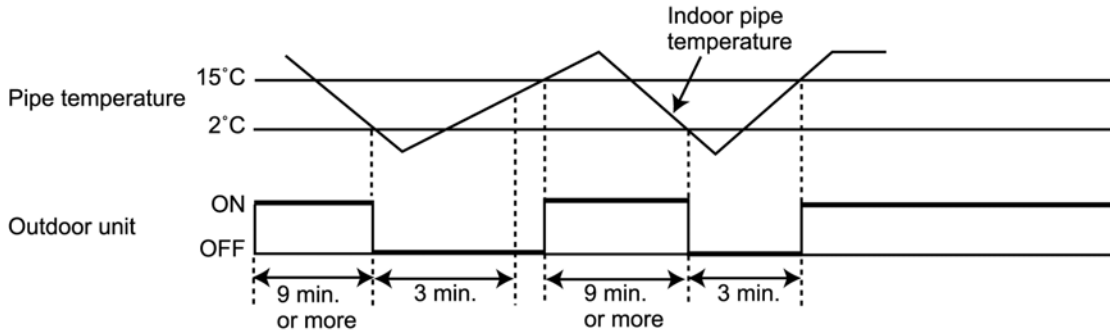

(The above illustration only shows the operation stops due to freezing prevention control of the indoor pipe temperature sensor.)

26.3. Heating mode operation time chart (Heat pump type)

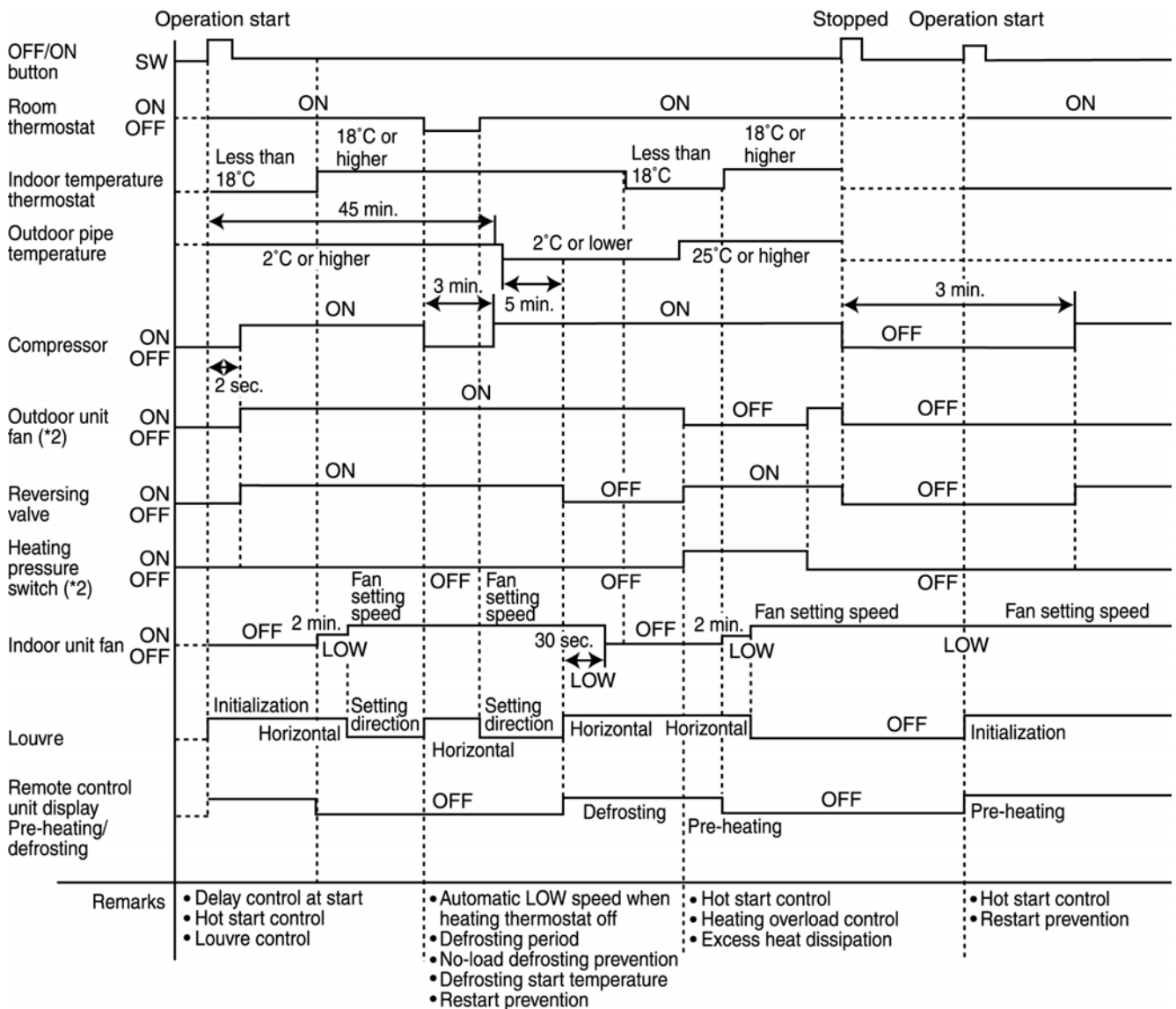

(*2)

Outdoor unit fan control during heating mode operation

When the compressor is on during heating mode operation (except during defrosting and when the liquid bypass valve is on), the outdoor unit fan is controlled by means of input (CN2) indicating whether the contact of the heating pressure switch on the outdoor unit circuit board is open or closed.

(At the start of heating mode operation, the fan operates at HI speed.)

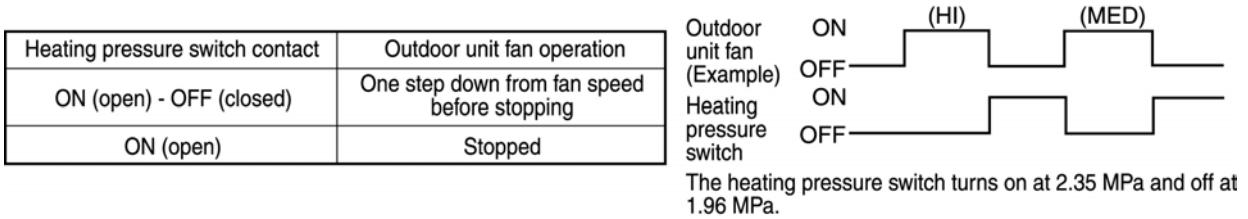

26.4. Hot starting

1. When heating mode operation starts

a. Start

Hot start control commences when heating mode operation starts.

b. Operation

“PREHEAT” appears on the remote control display. (Other displays remain unchanged.)

The indoor unit fan stops. In addition, during hot starting, the louvre stays at the horizontal position (angle 0°).

c. Cancelling

Hot starting will be cancelled when the compressor is turned on or the indoor unit pipe temperature sensor is 18°C or higher or after 1 minute of operation.

After cancellation, the “PREHEAT” display on the remote control disappears and the louvre operation returns to the previous setting.

(However, for 2 minutes after cancellation, the indoor unit fan operates at LOW speed, and then returns to the previous setting.)

<When hot start operation is cancelled by temperature>

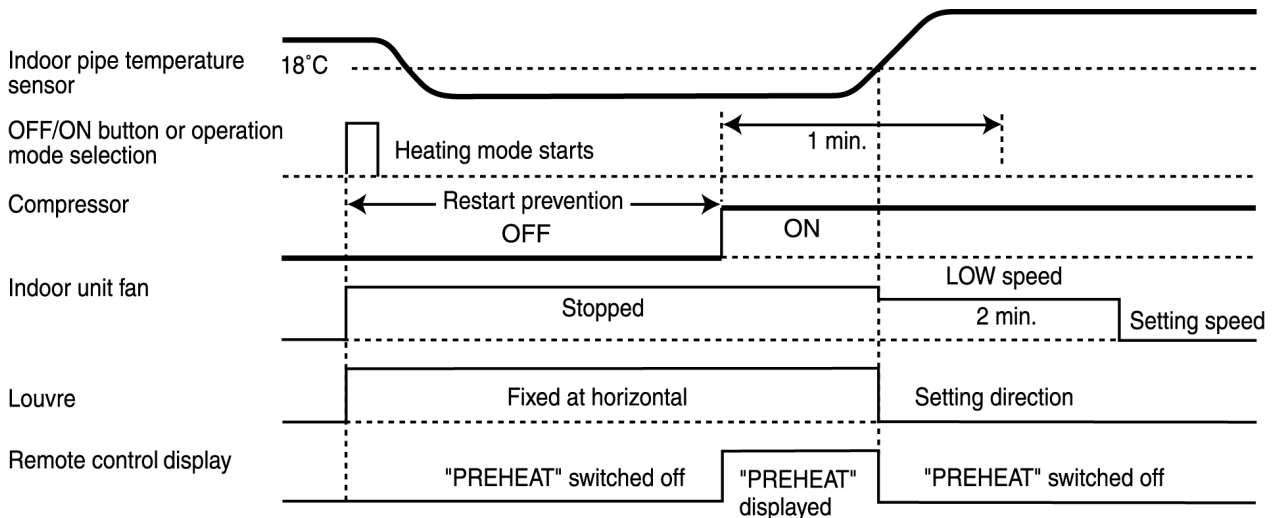

<When hot start operation is cancelled by time>

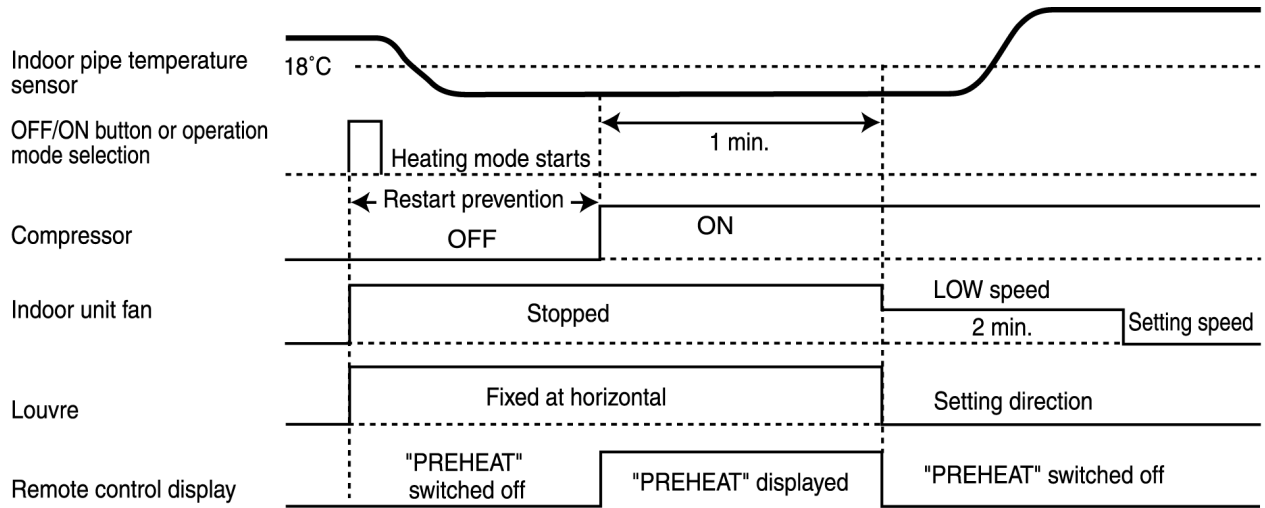

2. When defrosting is completed

a. Start

Hot start control commences when defrosting is completed.

b. Operation

"PREHEAT" appears on the remote control display. (Other displays remain unchanged)

The indoor unit fan stops. In addition, during hot starting, the louvre stays at the horizontal position (angle 0°C).

c. Cancelling

Hot starting will be cancelled when the temperature detected by the indoor unit pipe temperature sensor is 18°C or higher, or after a maximum 1 minute has passed since defrosting was completed.

After cancellation, the "PREHEAT" display on the remote control disappears and the louvre operation returns to the previous setting.

(However, the indoor unit fan operates at LOW speed for 2 minutes after cancellation, and then returns to the previous setting.)

<When hot start operation is cancelled by temperature>

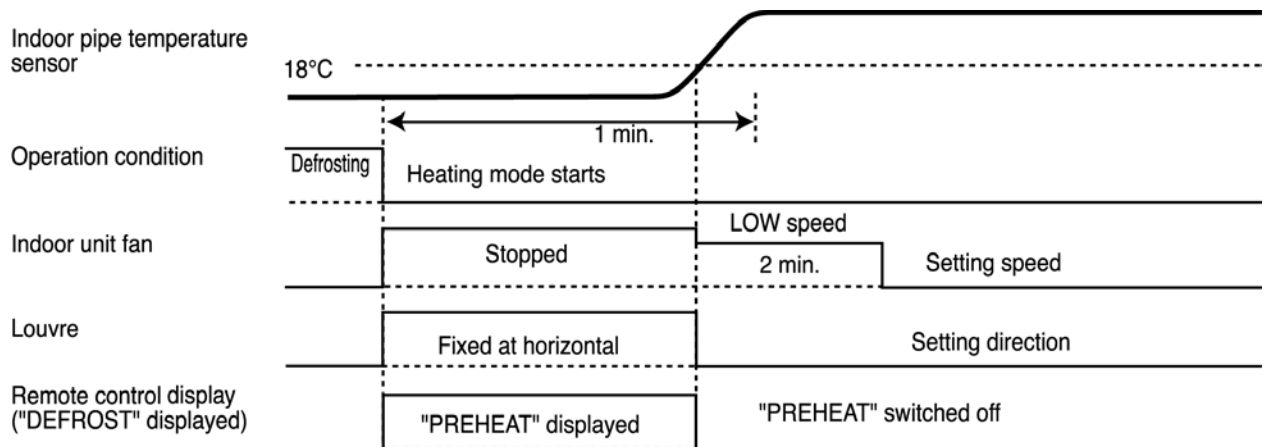

<When hot start operation is cancelled by time>

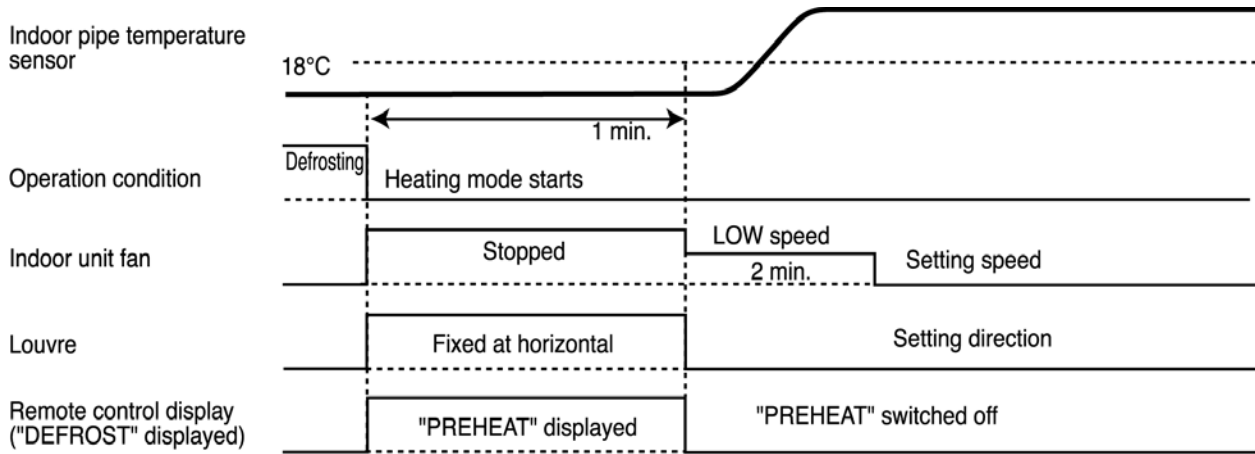

26.5. Indoor unit fan control when thermostat is off during heating mode operation

When the thermostat of the indoor unit turns off during heating mode operation, the indoor unit fan operates for 2 minutes at LOW and then stops. In addition, 5 minutes after the thermostat of the indoor unit turns off, the indoor unit fan operates at LOW for 10 seconds, and at 3 minutes interval after that, it switches back to LOW operation for another 10 seconds.

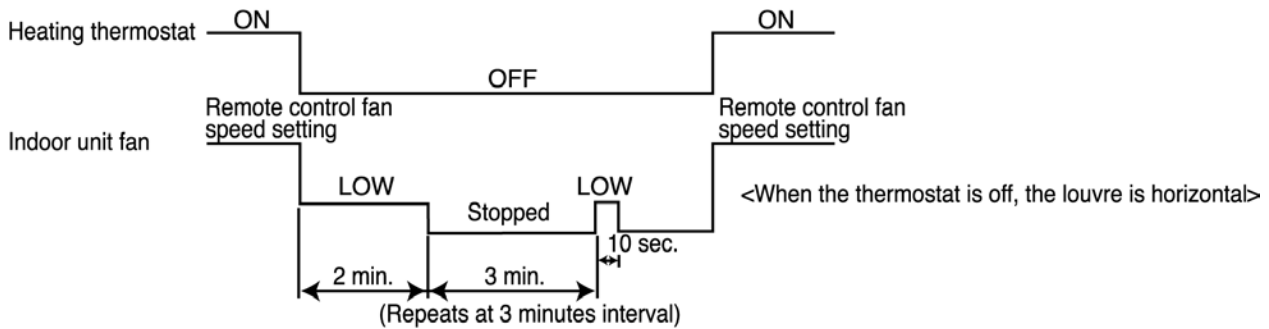

26.6. Excess heat dissipation for indoor unit

The indoor unit fan continue its operation for 30 seconds after heating mode operation turns off in order to dissipate excess heat.

1. When heating mode operation has stopped
(LOW speed for 30 seconds)
2. When operation is set to a mode other than heating by means of the OPERATION button
3. If operation starts again during the 30 seconds mentioned at (1)
(The fan operates at LOW speed for the remainder of the 30 seconds and then hot start commences.)

26.7. Defrost mode operation time chart

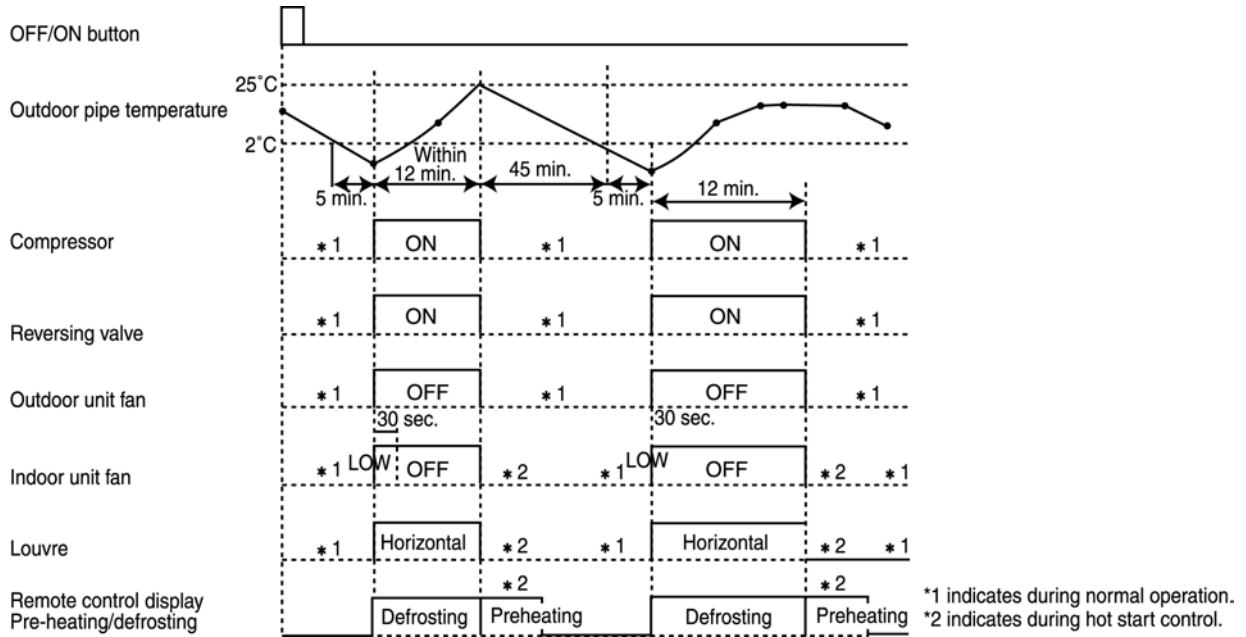

1. Start and completion of defrosting

a. Start

During heating mode operation (including automatic heating), after the 45 minutes of defrosting cycle time has passed, defrosting starts if the temperature detected by the outdoor unit heat exchanger outlet sensor is 2°C or lower continuously for 5 minutes.

However, if the outdoor unit fan is stopped, the start of defrosting will be delayed by 5 minutes.

Then, the defrosting cycle will be 50 minutes from the start of heating mode operation.

b. Completion

Defrosting mode operation will stop if the outdoor unit heat exchanger outlet sensor is 25°C or higher or after 12 minutes of operation.

c. Forced defrosting

If P8 on the outdoor unit circuit board is shorted while the compressor is on during heating mode operation and the temperature detected by the outdoor unit heat exchanger outlet sensor is 25°C or lower, defrosting is carried out regardless of the current starting conditions.

2. Operation

a. During defrosting, the outdoor unit turns on the compressor and turns off the outdoor unit fan and the reversing valve.

b. The indoor unit fan operates at LOW speed for 30 seconds upon defrosting starts. After this, the indoor unit fan turns off until defrosting is completed.

(During defrosting, the louvre of the indoor unit stays at horizontal position).

26.8. Indoor thermostat characteristics

1. Thermostat characteristics during cooling and heating modes.

Operation mode	Setting temperature (To)	Room temperature (°C)		
		Operation	Differential	
			2.0K	4.0K
Cooling	16	O N	18.0	—
		O F F	16.0	—
	31	O N	33.0	—
		O F F	31.0	—
Heating *1	16	O N	18.0	20.0
		O F F	20.0	22.0
	29~31 *1 (27~31)	O N	31.0	31.0
		O F F	33.0	33.0

1* If jumper wire J3 on the indoor unit circuit board is disconnected, the thermostat characteristics during heating become 2K or higher.

Thermostat characteristics during cooling and heating modes

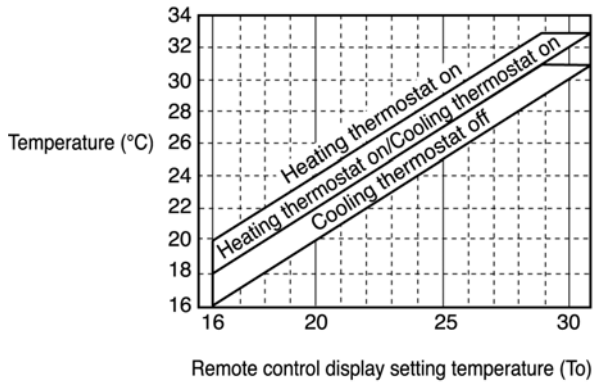

Thermostat characteristics during heating mode (when jumper wire J3 is disconnected)

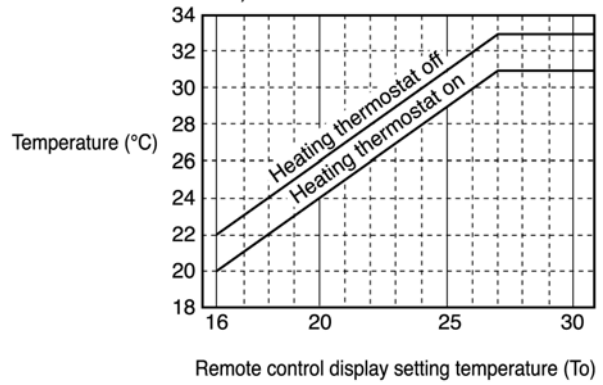

NOTE: If the remote control display setting temperature (T_o) is 29°C or higher, the heating thermostat turns on when the room temperature is 31°C.

2. Thermostat characteristics during dry mode.

During dry mode operation, cooling mode operation is carried out in accordance with the indoor temperature as shown in the table below.

Mode	Indoor Temperature (°C) T	Operation details	
1	$T \geq 28$	Cooling thermostat on	LO, Louvre horizontal
2	$28 > T \geq 25$	Cooling thermostat on 10 min./fan 5 min., alternate operation	LO, Louvre horizontal
3	$25 > T \geq 21$	Cooling thermostat on 5 min./fan 10 min., alternate operation	LO, Louvre horizontal
4	$21 > T$	Cooling thermostat off	LO, Louvre horizontal

(Differential is 1.5 K)

* When modes (2) and (3) are active, dry mode operation starts when the cooling thermostat turns on.

When modes (2) and (3) have been stopped, the 10 min./5 min. times have no relevance. However, if the indoor temperature is less than or equal to the remote control unit setting temperature, mode (4) is forcibly activated.

3. Thermostat characteristics during automatic changeover operation

a. Settings at the start of automatic changeover operation

When operation changes from other modes to automatic changeover mode, operation starts at the temperature characteristics given in the table below.

Indoor Temperature (T) °C	Initial setting
$T < \text{remote control display temperature} - 2 \text{ (°C)}$	Heating mode operation, thermostat on
$\text{Remote control display temperature} \geq T$	Heating mode operation, thermostat off (fan mode operation)
$\text{Remote control display temperature} \leq T$	Cooling mode operation, thermostat off (fan mode operation)
$\text{Remote control display temperature} + 2 \text{ (°C)} < T$	Cooling mode operation, thermostat on

2 (°C): Thermostat differential

b. Thermostat characteristic when switching between cooling and heating mode operation

Switching between cooling mode and heating mode operation is carried out as shown in the table below.

However, during automatic changeover operation, the operation will not change within 10 minutes after the thermostat has switched off, either cooling mode or heating mode.

(The 10 minutes timer will be cancelled when operation is changed to other modes (manually) or when operation stops and the thermostat turns on.)

Indoor Temperature (T) °C	Operation switching
$T \geq \text{Remote control display temperature} + 3 \text{ (}^\circ\text{C)}$	Heating mode → Cooling mode
$T \leq \text{Remote control display temperature} - 3 \text{ (}^\circ\text{C)}$	Cooling mode → Heating mode

c. Thermostat characteristics during cooling mode and heating operation

The thermostat on/off characteristics in both operation modes are given in the table below.

Operation mode	Indoor Temperature (°C) T	Operation
Cooling mode	$T > \text{Remote control display temperature} + 2 \text{ (}^\circ\text{C)}$	Cooling thermostat on
	$T \leq \text{Remote control display temperature}$	Cooling thermostat off
Heating mode	$T < \text{Remote control display temperature} - 2 \text{ (}^\circ\text{C)}$	Cooling thermostat on
	$T \geq \text{Remote control display temperature}$	Cooling thermostat off

Indoor temperature thermostat characteristics during automatic changeover operation

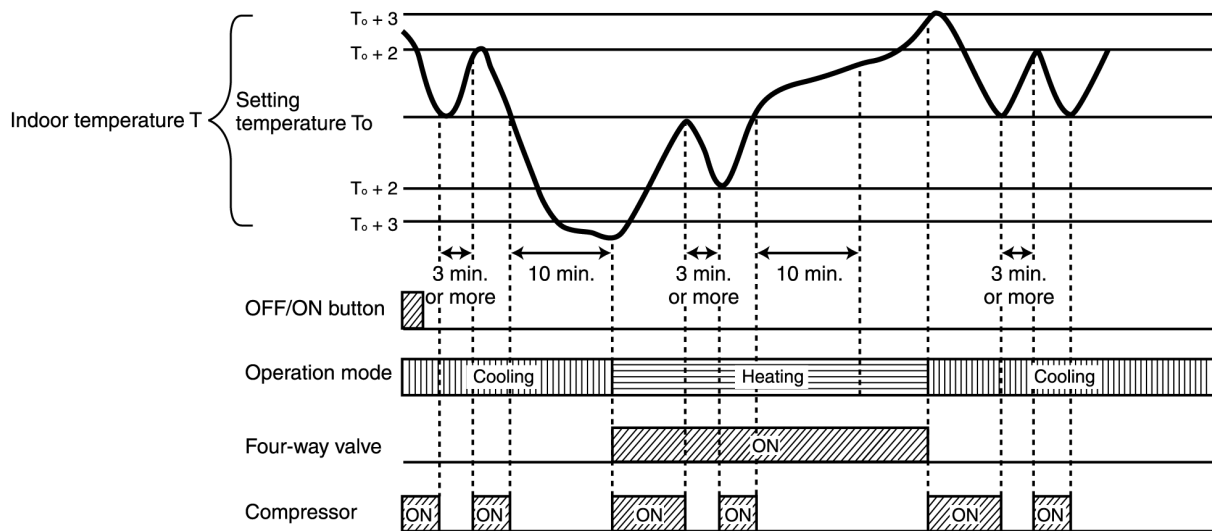
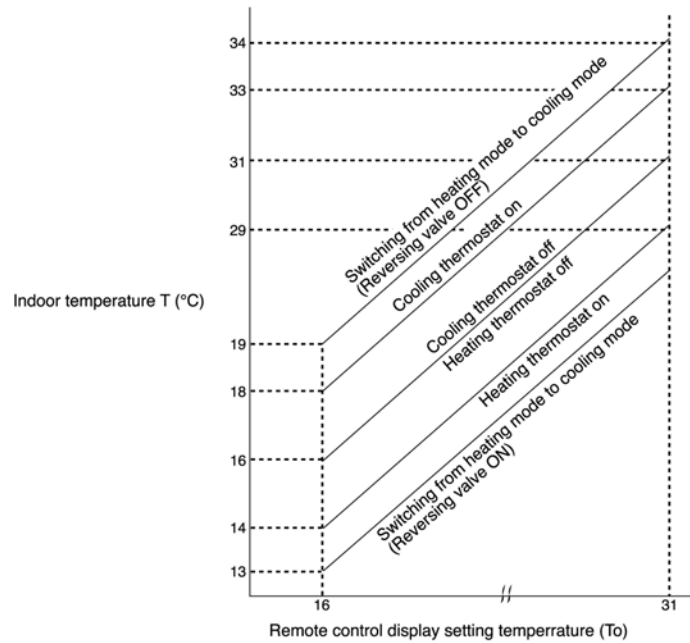

Automatic cooling/heating mode operation time chart

26.9. Indoor unit fan control

1. Fixing at LO, MED or HI

When LO, MED or HI is set, the relay switches and operation is carried out at that setting.

2. Automatic fan speed

When set to AUTO, the indoor unit fan operation changes as shown in the table below.

(Indoor temperature) - (Setting temperature) (Units: K)

Mode / Fan Speed	HI	MED	LO
Cooling	+3 or higher	+1.5 ~ 3	Less than +1.5
Heating	-3 or lower	-1.6 ~ - 3	More than -1.5
Fan	MED irrespective of temperature		

26.10. Forced operation during restart

The compressor will not stop operating for 3 minutes after cooling mode operation starts, even if the indoor unit thermostat turns off.

(However, the compressor will stop operating during this time if the indoor unit air intake temperature drops to 16°C and below during cooling mode operation.)

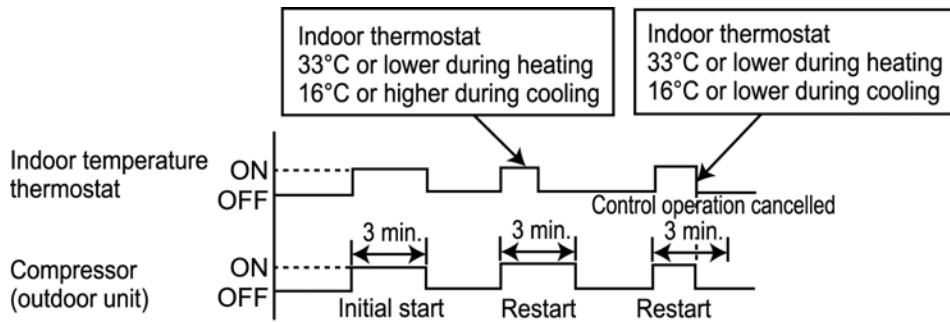

26.11. Louvre control (models with louvre)

1. When main power is turned on

When the power is turned on, indoor unit louvre position detection is carried out twice and then the indoor unit louvre stops.

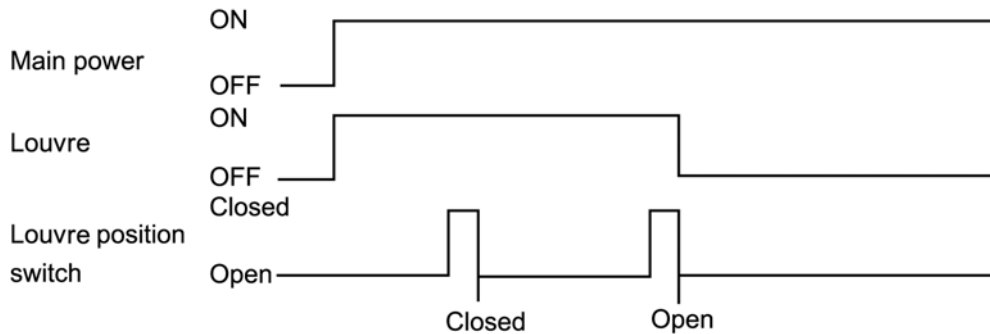

2. During initial operation

When the OFF/ON button is pressed to start the operation, the louvre moves through one full cycle, and then swings automatically (if AUTO has been set using the remote control) or moves to the setting angle (if MANUAL has been set using the remote control).

3. When operation stops

When the OFF/ON button is pressed to stop the operation, the louvre moves through one full cycle, and then stops in the down position, regardless of the remote control setting.

4. When thermostat is off

When operation is stopped by the indoor thermostat, the louvre moves through one full cycle, and then stops in the horizontal position, regardless of the remote control setting.

26.12. Outdoor unit fan excess heat dissipation control

1. When the operation is stopped while the compressor is in operation, the outdoor fan will run at SUPER HI fan speed for approximately 60 seconds and then stops.

26.13. Discharge temperature control

1. Operation

When the discharge temperature sensor detects a temperature of 100°C or higher during cooling mode operation, the liquid bypass valve will be turned on.

2. Cancelling

When the discharge temperature sensor detects a temperature of 70°C or lower, the liquid bypass valve will be turned off.

26.14. Emergency operation

When the emergency operation switch (DSW1) on the outdoor unit printed circuit board is set to emergency, the emergency operation is enabled. This allows normal operation to continue, with all abnormalities other than a discharge temperature abnormality, high pressure abnormality or overcurrent abnormality being ignored.

26.15. DIP switch settings

- Indoor unit printed circuit board (DSW1)





No.	Setting type	Factory shipment	Remarks
1	Group address setting (twin/triple address setting)	OFF	When group operation is being carried out using the remote control, this address is set in order to control the order of starting for the indoor units. (If No. 8 is ON, twin/triple address setting is carried out.)
2		OFF	
3		OFF	
4		OFF	
5	Automatic restart	ON	When set to ON, operation after a power outage resumes at the settings which were in effect before the outage. (The backup time is semipermanent.)
6	Filter sign time	OFF	When set to ON, the filter sign times can be set to 2,500 times.
7	Louvre control	ON	When set to OFF, louvre control is disabled.
8	Twin/triple slave unit setting	OFF	When set to ON, the unit is designated as a slave unit.

27 WIRED REMOTE CONTROL INSTALLATION MANUAL

Wired Remote Control Installation Manual

- Before installing the wired remote control, be sure to thoroughly read the "Notes with regard to safety" section of the installation manual provided with the indoor unit.
- After installing the wired remote control, carry out a test operation to check that the remote control functions properly, and also explain the operation and cleaning procedures to the customer in accordance with the details in instruction manual. Furthermore, ask the customer to keep this installation manual and the instruction manual in a safe place for later reference.

1. ACCESSORIES SUPPLIED WITH WIRED REMOTE CONTROL

Name	Q'ty	Diagram	Remark	Name	Q'ty	Diagram	Remark
Remote control	1			4mm screw	3		Installing the remote control to a wall
				M4 screw	3		Installing the remote control to an outlet box
Remote control cable	1		Length (10m)	Round terminal	2		Connecting to indoor unit terminal block

2. NOTES REGARDING WIRED REMOTE CONTROL SETTING-UP LOCATION

- Select a place where the remote control can be operated easily (after obtaining approval from the building's owner).
- Install in a place which is away from direct sunlight and as free from humidity as possible.
- Install in a place which is as flat as possible to avoid warping of the remote control. (If installed to a wall an uneven surface, damage to the LCD case or operation problems may result.)
- Install in a place where the LCD can be seen easily. If the remote control is installed somewhere which is too low or too high, it may be difficult to read the LCD. (Standard height from the floor is 1.2 to 1.5 meters.)
- Avoid installing the remote control cable near refrigerant pipes or drain pipes.
- Install the remote control cable at least 5 cm away from other electric wires (including stereo and TV cables) to avoid mis-operation (electromagnetic noise).
- If passing the remote control cable through a wall, be sure to install a water trap above the cable.
- Allow sufficient space around the remote control as shown in the illustration at right.
Secure the remote control lower case to the wall or to an outlet.

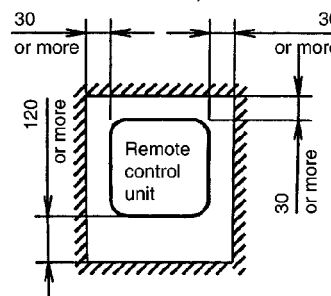

3. REMOTE CONTROL INSTALLATION

- Be sure to turn off the main power before installing and connecting the remote control. (If the remote control is connected while the power is still turned on, the remote control displays may not appear.)
If no displays appear on the remote control, check while referring to "If no remote control displays appear" in 5 Test operation.
- The remote control cable is live during use, so take care not to short it.

Remote control wiring

- Connect the indoor unit and the remote control as shown in the illustration below.
- The remote control cable is non-polar.
- At the time of shipment from the factory, the connector cable used to connect the terminal block and connector CN1 is disconnected. When connecting the remote control wiring and installing the remote control, be sure to connect the cord to the connector CN1.

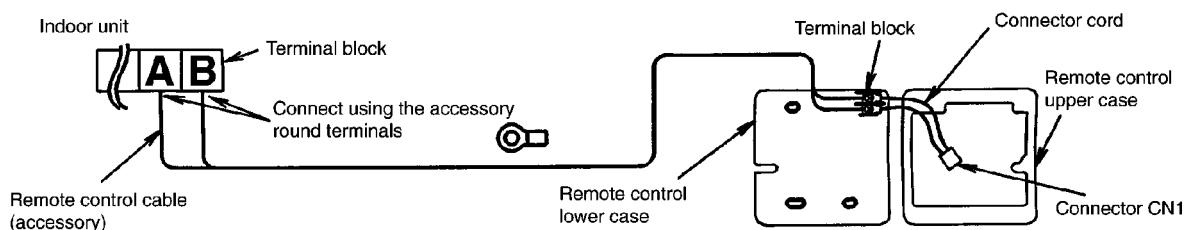

Extending the remote control cable

- Solder a sheathed PVC cord or cable (0.5 – 2 mm²) with specifications among those given below to the remote control end of the accessory remote control cable (10 m).
 - * PVC round cable IEC 502
 - * 600V PVC-insulated PVC sheathed round cable IEC 227-4
 - * 600V PVC-insulated PVC sheathed flat cable IEC 227-4

NOTE The maximum possible length for the remote control cable is 200 m.

Remote control installation procedure

- Remove the remote control lower case.
(Insert a flat-tipped screwdriver or similar 2 to 3 mm into one of the gaps at the bottom of the case, and then twist the screwdriver to open. [Refer to the illustration at right.])
Be careful not to damage the lower case.
- Secure the lower case to the wall or outlet box.
(Refer to the illustration at right for the embedded and exposed positions for remote control cable.)

NOTE

- Be sure to use only the accessory screws.
- Do not bend the lower case when tightening the screws.
(If the screws are overtightened, damage may result.)
- Do not remove the protective tape which is affixed to the upper case circuit board.
- If installing the remote control with the remote control cable exposed, use pliers to cut a notch into the upper case. (The feeding-out direction can be either up or to the left or right)
- Strip the end of the remote control cable which is to be connected to the remote control. (Refer to the illustration at right)
- Route the remote control cable inside the lower case in accordance with the intended feeding-out direction. (Refer to the illustration below.)
Securely connect connector CN1. (If it is not connected the remote control will not operate.)

NOTE After connecting the connector, do not suspend the upper case by its own weight, otherwise the connector cord may break.

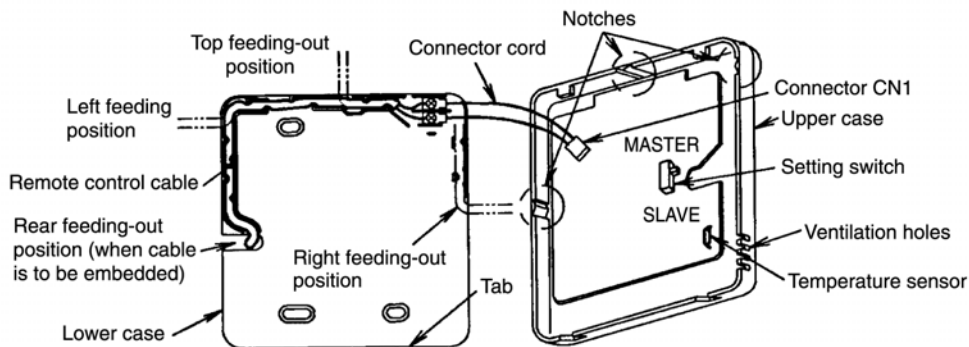
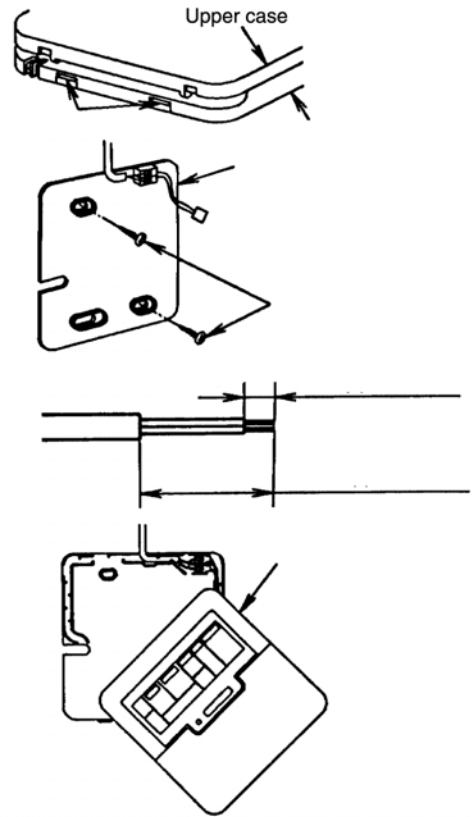

- If controlling using two remote controls, refer to "Control using two remote controls" in "4 Settings".
- Secure the upper case to the lower case.
(Hook the upper tab of the upper case into the lower case, and then push the upper case until it snaps shut onto the lower case tab, while being careful not to clamp the remote control cable and the connector cord.)

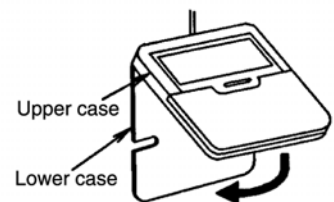

If remote control cable is embedded

1. Embed an outlet box (JIS C 8336) into the wall, and then secure the remote control base plate to the outlet box with the two accessory M4 screws. Make sure that the base plate is flat against the wall at this time, with no bending (looseness).
2. Pass the remote control cable into the box and then install the remote control.

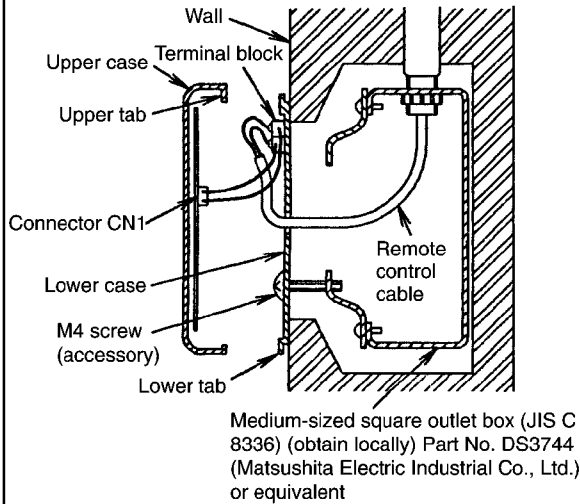

If installing with the remote control cable exposed

1. Secure the remote control base plate to the wall with the two accessory 4 mm screws.
2. The feeding-out direction for the remote control cable can be either up or to the left or right. (Refer to the illustration above.) After determining the feeding-out direction, use pliers to make a notch in the cover.
3. Route the remote control cable as shown in the illustration above. Pull the cord firmly around the outside of the base plate at this time.

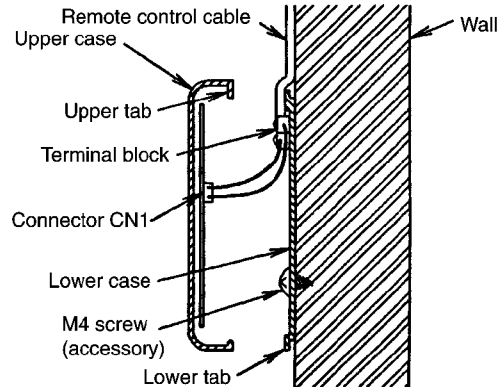

4. SETTINGS

Control using two remote controls

- Up to two remote controls can be installed for a single indoor unit, and either remote control can be used to operate the indoor unit.
- The indoor unit can be operated with the last switch pressed having priority.
 - (1) Decide which is to be the master and which is to be the slave remote control.

The master or slave states of the remote control is set automatically. The MASTER/SLAVE setting switch can also be used to make the setting manually, however if a manual setting is made, that manual setting has priority.

Be sure to turn off the main power before making a manual setting.
 - (2) Connect the remote controls.

Connect both remote control to terminals (A) and (B) on the indoor unit terminal block (non-polar).

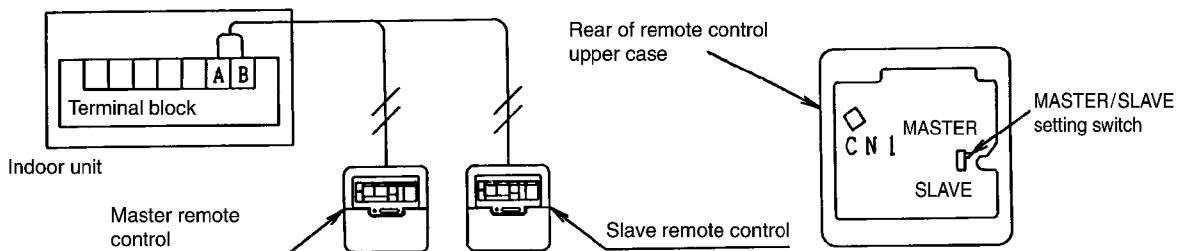

Group control

- All in group will be remote control thermistor setting when using the remote control thermistor.
- Up to a maximum of 16 indoor units can be connected at the time of group control. (Do not connect heat pump unit with cooling only unit.)
- Indoor unit No. is possible to set automatically at the time of group control. However, which indoor unit will be which number is unknown.

Indoor unit No. is also possible to set manually with DIP switches. Since manual address setting is priority, when performing automatic address setting after doing manual setting turn off all DIP switches from No. 1 to No. 4, and then stop the operation and press three switches such as [AIR SWING AUTO] • [OPERATION] • [A/C No.] at the same time.

(Do not use manual address setting and automatic address setting together.)

Manual Setting	Indoor unit No.	1	2	3	4	5	6	7	8
	DIP switch (DSW1) address setting on indoor unit printed circuit board.								
	A/C No. setting	Unnecessary operation	1 ~ ON	2 ~ ON	1, 2 ~ ON	3 ~ ON	1, 3 ~ ON	2, 3 ~ ON	1, 2, 3 ~ ON
	Indoor unit No.	9	10	11	12	13	14	15	16
DIP switch (DSW1) address setting on indoor unit printed circuit board.									
A/C No. setting	4 ~ ON	1, 4 ~ ON	2, 4 ~ ON	1, 2, 4 ~ ON	3, 4 ~ ON	1, 3, 4 ~ ON	2, 3, 4 ~ ON	1, 2, 3, 4 ~ ON	

Automatic address resetting for group control

- The address settings for group control (air conditioner Nos. 1 to 16) can be reset automatically.
 - While operation is stopped, press the AUTO switch, A/C NO. and OPERATION switches simultaneously.

Switching the thermistor

- The temperature detection thermistor can be switched between the thermistor at the indoor unit and the thermistor at the remote control. However, do not switch to the remote control thermistor if using two remote controls.
 - While operation is stopped, press and hold the TEST RUN switch, and then press the UP and DOWN switches together.
 - "00" or "01" will appear in the time display.
 - Press the ▲ or ▼ timer switches to switch display between "00" and "01".
 - "00" ... Indoor unit setting (factory default)
 - "01" ... Remote control setting
 - Press the SET switch. (Be sure to press the SET switch so that normal operation mode can be resumed.)
- Repeat the procedure in steps (1) to (4) to change the setting again.

Energy save setting

- Upper and lower limits can be set for the setting temperature during cooling and heating operation (Energy save setting)
 - While operation is stopped, press the UP and DOWN switches simultaneously.
 - "0" (zero) will flash in the clock display at this time, so press the SET switch.
 - To set an upper limit (Setting a temperature above the energy save temperature will not be possible).
 - Press the OPERATION switch unit HEAT is displayed.
 - Press the UP or DOWN switch to set the temperature.
 - Press the SET switch.
 - Example: If the heating display is set to 28C, setting the temperature to higher than 28C will not be possible.
 - To set a lower limit (Setting a temperature below the energy save temperature will not be possible).
 - Press the OPERATION switch unit COOL is displayed.
 - Press the UP or DOWN switch to set the temperature.
 - Press the SET switch.
 - Example: If the cooling display is set to 22C, setting the temperature to lower than 22C will not be possible.
 - If the CANCEL switch is pressed during steps (3) or (4) above, the energy save setting will be cleared.
- Press the SET switch or the CANCEL switch to return to normal operation mode after making an energy save setting in steps (3) to (5).

5. TEST OPERATION

- Turn on the main power.
- After 3 minutes have passed since the power was turned on, press the OFF/ON switch on the remote control. (No operation occurs within 3 minutes after the power was turned on.)
- Press the TEST RUN switch within 1 minute of pressing the OFF/ON switch.
- Next, select the operation mode. (Be sure to select cooling mode first, and run the unit in this mode for 5 minutes or more.)
- Press the OFF/ON switch or the TEST RUN switch to cancel test operation.
- Test operation will be cancelled automatically after 30 minutes.

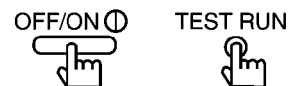

If no remote control displays appear

- Check whether LED1 (green) on the indoor unit printed circuit board is illuminated or switched off. If it is switched off, check the circuits on the indoor unit printed circuit board.
- Check once more that the remote control cable is securely connected. (Check for loose terminals, poor contacts, connection positions terminal block, etc.)

- If the above checks show that nothing is wrong but nothing appears on the remote control display, it is possible that the remote control was connected while the main power was still turned on.
If such is the case, carry out the following.
- Set DIP switch (DSW1) No. 1 to 4 the ON position, and then turn on the main power. If the display appears after about 30 seconds, turn DIP switches 1 to 4 to OFF position.

6. SELF-DIAGNOSIS FUNCTION

The LED1 (green) indicators on the indoor unit and outdoor unit printed circuit boards illuminate to indicate that the printed circuit boards are operating normally. If the LEDs are switched off or are flashing irregularly, check the power supply, and turn it off and then back on again.

If "CHECK" is flashing on the timer

- If the "CHECK" display on the wired remote control is flashing, the details of the problem(s) are displayed on the timer display screen each time the CHECK switch is pressed.
- Further details of the problem can be displayed by pressing the SELECT switch while the general problem details are being displayed.

Example of current problem display

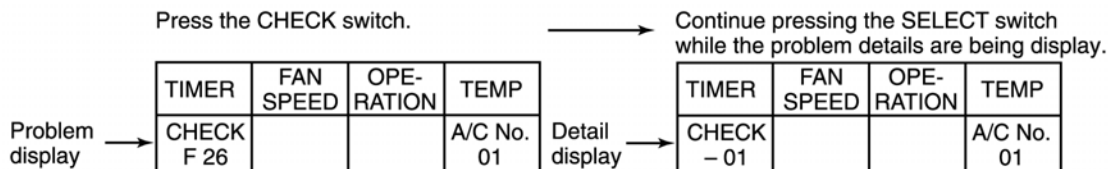

If "CHECK" is not flashing on the timer

- If the "CHECK" display on the wired remote control is not flashing, press the CHECK switch continuously for 5 seconds or more to display the problem details for the last problem or the problem before that.
- You can then switch between the display for the previous problem and the problem before that by pressing the timer ▲ or ▼ switches.
- Press the CHECK switch once more to return to the normal display.

Example of previous problem display

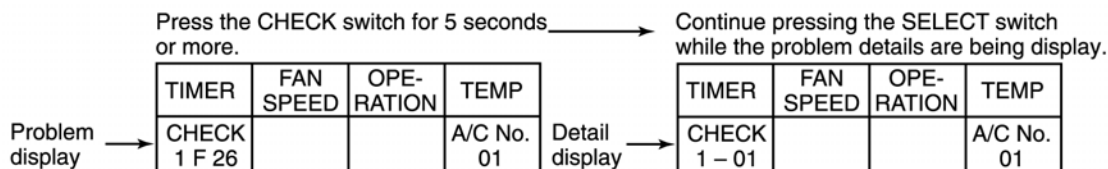

Example of abnormality display before previous display

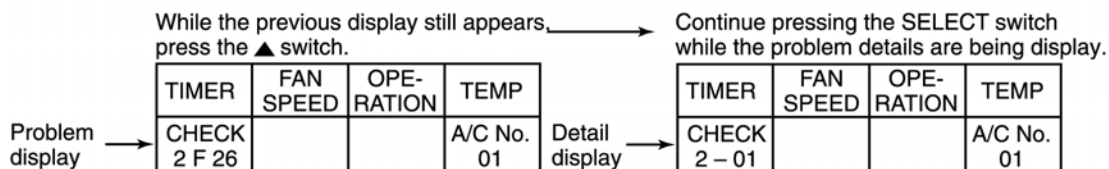

- The display can be switched between the previous problem and the one before that by pressing ▲ and ▼ switches.
- After eliminating the cause of the problem, press the CHECK switch once more to return to the normal display.
- If the problem disappears and operation returns to normal, CHECK display on the remote control will switch off, but the self-diagnosis LED will remain illuminated until operation is resumed.

28 WIRELESS REMOTE CONTROL INSTALLATION MANUAL

Wireless Remote Control Installation Manual

- Before installing the wireless remote control, be sure to thoroughly read the “Notes with regard to safety” section of the installation manual provided with the indoor unit.
 - After installing the wireless remote control, carry out a test operation to check that the remote control functions properly, and also explain the operation and cleaning procedures to the customer in accordance with the details in the instruction manual.
- Furthermore, ask the customer to keep this installation manual and the instruction manual in a safe place for later reference.

1. Accessories supplied with the wireless remote control

No.	Name	Qty
1.	Wireless Remote Control	1
2.	R03 battery	2
3.	Holder (for securing remote control)	1
4.	Holder fixing screw	2
5.	Receptor unit	1
6.	Receptor unit fixing screw	2
7.	Joint cord	1
8.	Cord clamp	8
9.	Plastic tie	3
10.	Installation manual	1

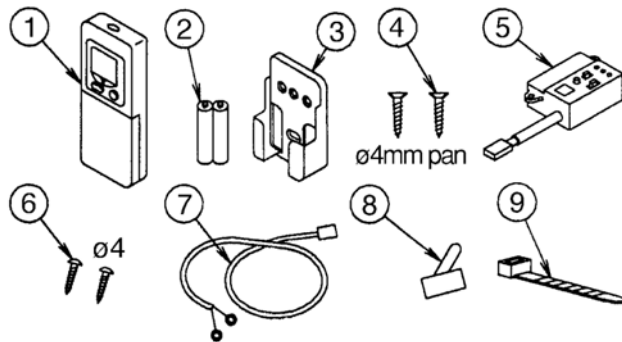

2. Points and notes regarding wireless remote control setting-up location

- The wireless remote control can be used to operate indoor units at a maximum range of 8 metres while directly facing in front of the indoor unit.
- If the remote control is at an angle to the receptor unit, the operation range may become shortened.
- The accessory receptor unit must be attached to the veneer panel.
- The receptor unit for the wireless remote control should be in a place where it will not be affected by direct light from any fluorescent lights. (Refer to the illustration below.)
(If using an inverter-type fluorescent light, keep the receptor unit at least 1m away from the light, otherwise remote control operation may not work properly.)

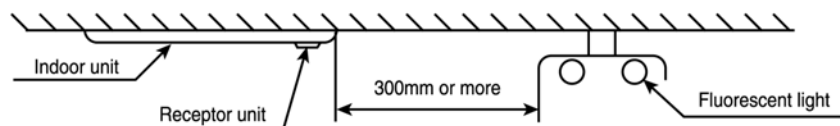

- If installing in a place where a power supply is generating electromagnetic noise, take measures such as installing a noise filter.
- Install at least 3m away from any noise sources and shield the electric cables using an iron conduit pipe.
- Install at least 1m away from equipment such as TVs and radios. (Otherwise picture distortion or static may occur.)

Wireless remote control installation procedure

- Installing the wireless remote control to a wall (for remote control storage).

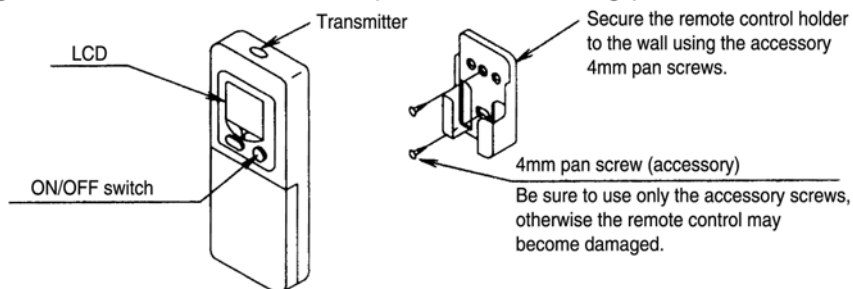

- If using a single remote control to operate several air conditioners, address setting will be required. (Refer to later in this manual.)
- For twin and triple types, install to the main unit only. (Accordingly, the installation and wiring operations described later in this manual are for the main unit only.)

Inserting the batteries

- Remove the battery compartment cover of the wireless remote control, and then insert the two accessory R03 size batteries. (Be sure not to make a mistake with the polarities.)

NOTE

The accessory batteries are to be used when checking operation. They should be replaced with new batteries as soon as possible. (Be sure not to make a mistake with the polarities.)

NOTE

- When inserting the batteries for the first time, or when replacing the batteries, the remote control may not work. In such cases, use a ballpoint pen or similar object to push the reset switch. The remote control should then start working normally.
- Replace the batteries with two new batteries of the same type.
- Rechargeable (Ni-Cd) batteries differ in aspects such as shape and performance, and thus cannot be used.

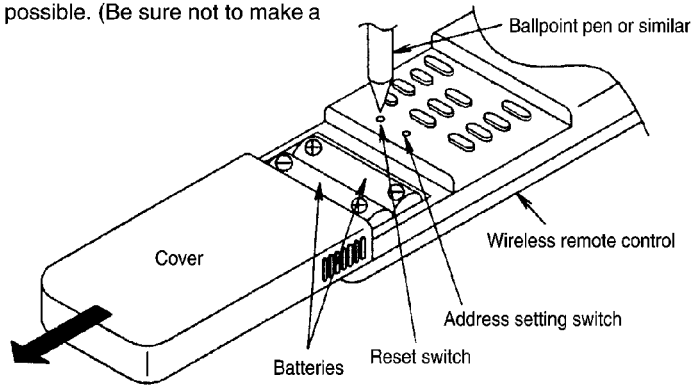

3. Installing the receptor unit

Receptor unit (for four-way cassette type) assembly procedure

1 Attach the receptor unit onto the decorative panel of the indoor unit as shown in the figure below.

1. Remove the "sealing cover" attached at the factory. (The sealing cover will no longer be required.)
2. Attach the receptor unit with the screws supplied.

2 Route the joint cord for wiring and connect it to the terminals <A> and in the control box of the indoor unit. (No polarity.)

1. Route the joint cord for wiring as shown in the figure (figure of the back of decorative panel) below.

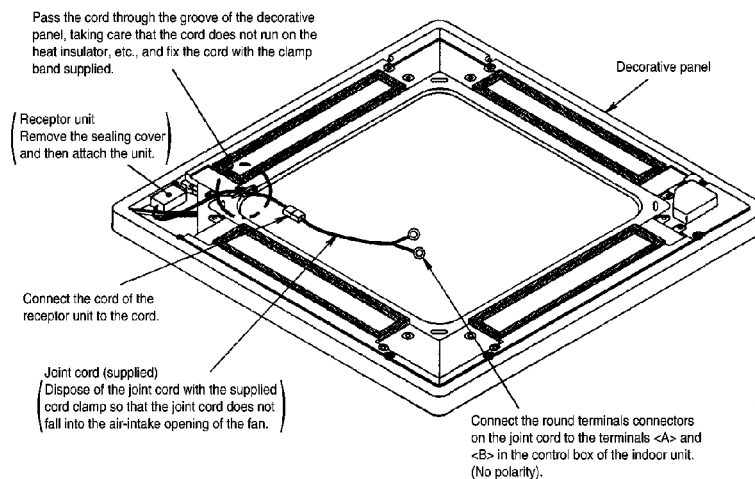

- Remove the control box cover by removing the two fixing screws and connect the joint cord to the terminals <A> and in the control box.

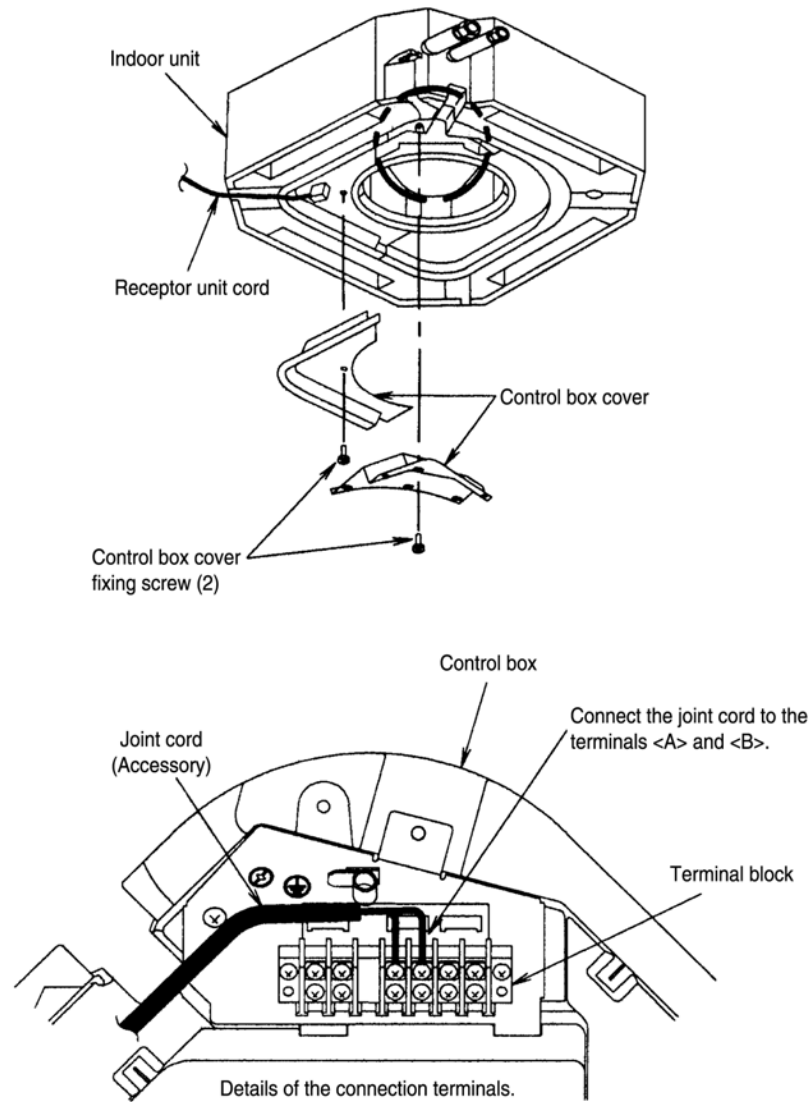

Receptor unit (for ceiling type) assembly procedure

- Attach the receptor unit onto the indoor main unit as shown in the figure below.

- Remove the air-intake grille and the side cover.
To remove the side cover, remove the fixing screw each on the left and the right and pull the side cover towards you.
(Refer to the Installation Manual supplied with the indoor main unit.)

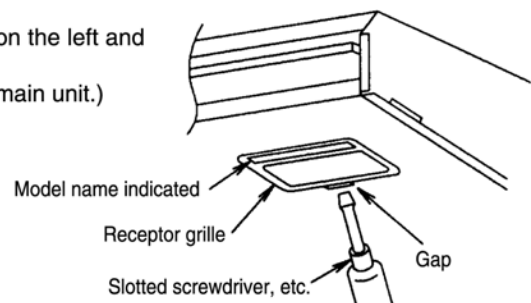

- Remove the receptor grille (component on which the model name is shown) to the right on the air-blow opening.
(Fixed with three tabs.)
(There should be a gap at the rear center of the receptor grille. Insert the tip of a slotted screwdriver, etc., 2 to 3mm into the gap and pry off the receptor grille to remove.)

- Remove the decorative panel for the receptor grille.
(Press the decorative panel from the back to remove.)
(The decorative panel will no longer be required.)

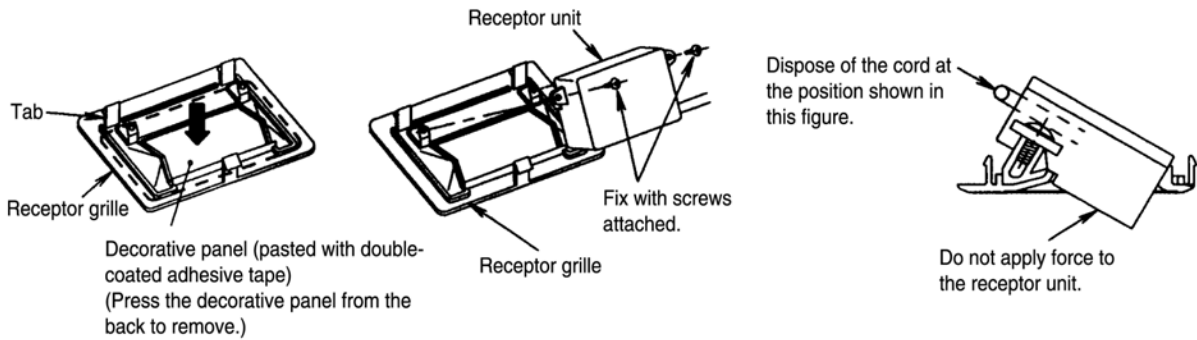

- Attach the receptor unit for the wireless remote control onto the receptor grille. (Use two screws to fix.)
- Draw out the cord of the receptor unit through the feed-through hole toward the side plate and attach the receptor grille onto the main unit. Hook the three tabs onto the receptor grille to attach the receptor grille on the main unit. (Press in the receptor grille until a click sound is heard.)

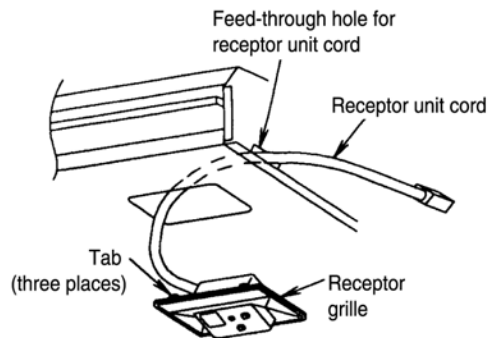

2 Route the joint cord for wiring and connect it to the terminals <A> and in the control box of the indoor unit. (No polarity)

- Route for wiring the cord as shown in the figure to the right.
- Remove the control box cover by removing the two fixing screws and connect the joint cord to the terminals <A> and in the control box.

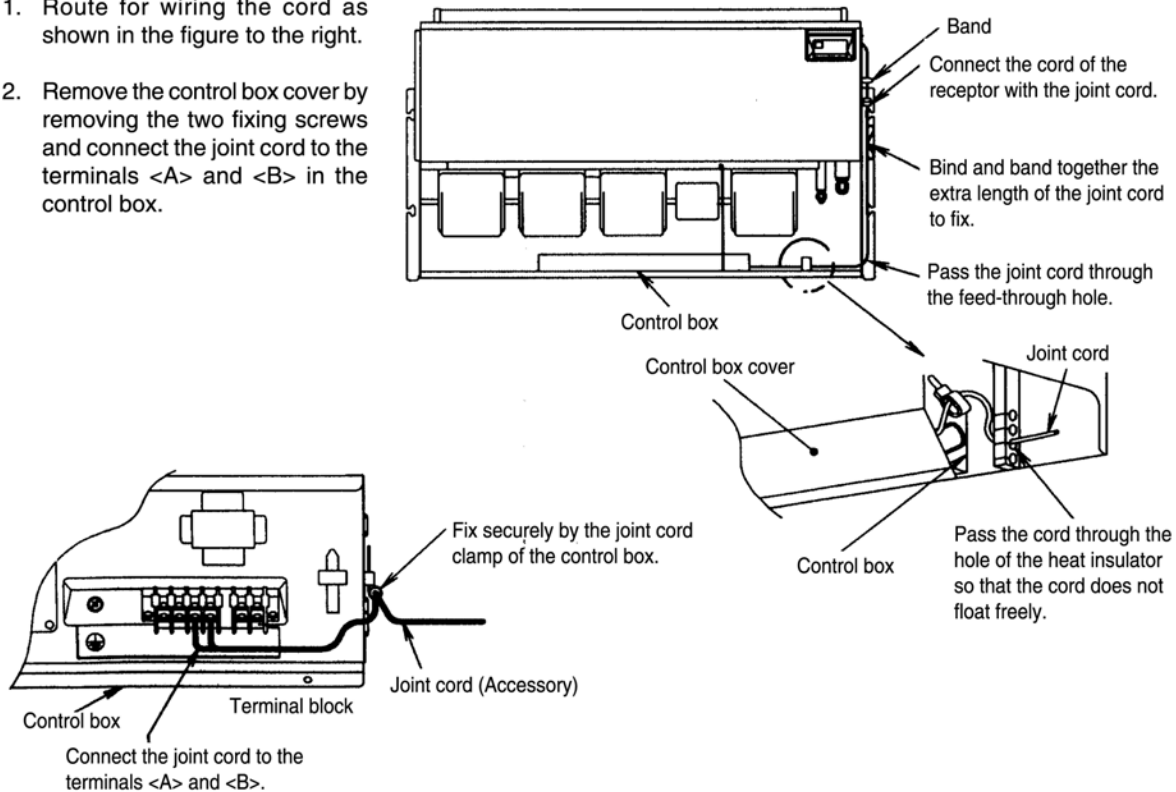

4. Receptor unit wiring

- Connect the indoor unit and the receptor unit as shown in the illustration below.
- If the indoor unit does not operate even when the wireless remote control is used to turn it on, check the indoor unit power supply.

If LED1 (green) on the indoor unit printed circuit board is illuminated to show that the power supply is normal, turn on the EMERGENCY switch (⓪) of the receptor unit. If the indoor unit still does not operate, even when the EMERGENCY switch (⓪) is turned on, turned off the indoor unit power supply, check that all of the DIP switches 1 to 4 (DSW1) on the indoor unit printed circuit board are set to ON and then turn the power back on.

* If the optional wired remote control has been connected, check the remote control display, and set all the DIP switches 1 to 4 (DSW1) to OFF while the power is still turned on.

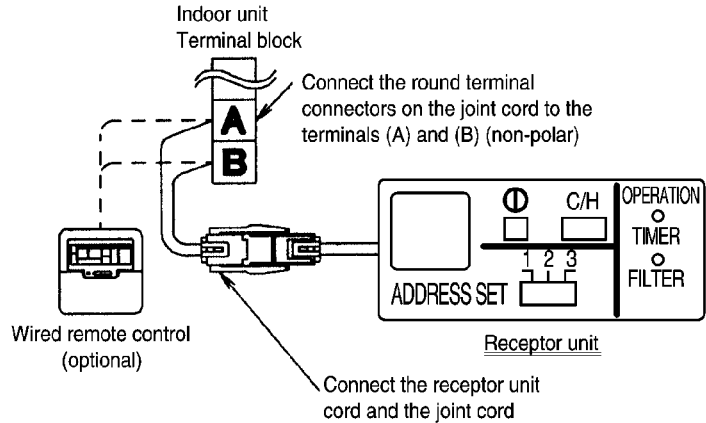

Address setting for wireless remote control and receptor unit (only when using more than one indoor unit.)

- Only the air conditioner units whose receptor unit address numbers match the remote control address number can be operated.
- At the time of shipment from the factory, the address numbers for both the wireless remote control and the receptor unit are set to "1". (When using only one indoor unit, the indoor unit can be used without changing the factory default settings.)

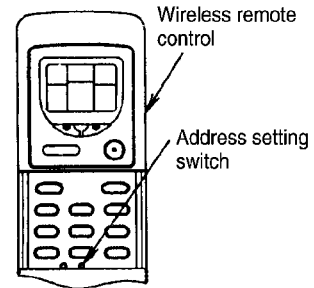

Press the address setting switch with a ballpoint pen or similar object to change the address setting.

The address number displayed on the LCD changes in the order of [ADDRESS1] → [ADDRESS2] → [ADDRESS3] → [GROUP] → [ADDRESS1] each time the switch is pressed.

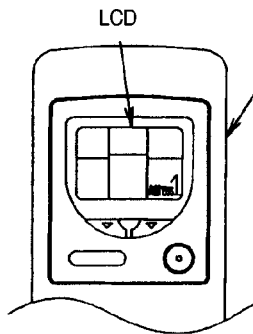

Only the air conditioner units whose address numbers match the address number on the LCD can be operated.

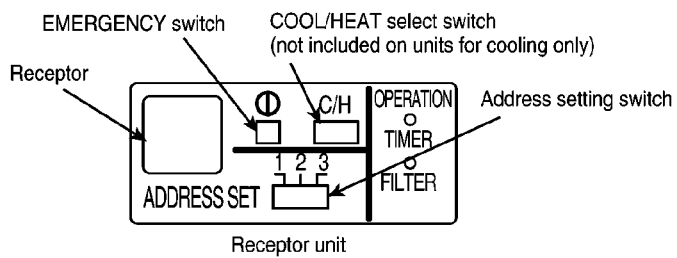

NOTE

- If the batteries are replaced or the remote control is reset, the address setting will return to ADDRESS1, so you will need to repeat the address setting again. All setting details which are stored in memory will be cleared, so you will need to repeat the settings.
- If the address is set to GROUP, more than one indoor unit can be operated at the same time. (The indoor units can be operated by a single remote control regardless of the address number settings on the receptor units.)

Receptor unit address setting		
Address setting switch	1 2 3	Address1
	1 2 3	Address2
	1 2 3	Address3

Example: If the address numbers for all the indoor units are changed, other indoor units may operate accidentally due to signal interference.

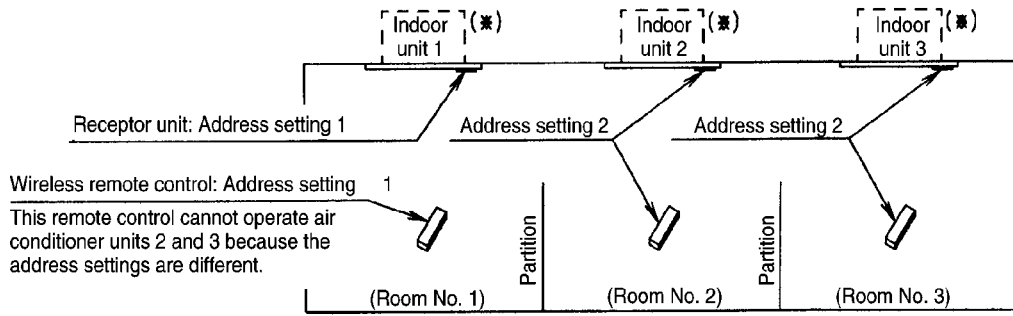

Control using two remote controls

- If both the wireless remote control and the optional wired remote control are being used together, either one remote control can be used to operate the indoor units.
- The optional wired remote control can only be connected to the indoor unit besides the one with the receptor unit.
- Two wireless remote control cannot be connected at the same time.
- When using the wireless remote control and the optional wired remote control, the MASTER/SLAVE setting will not be necessary.

Group control

- When using group control, be sure to install the receptor unit to indoor unit No. 1. (Refer to the illustration below.)

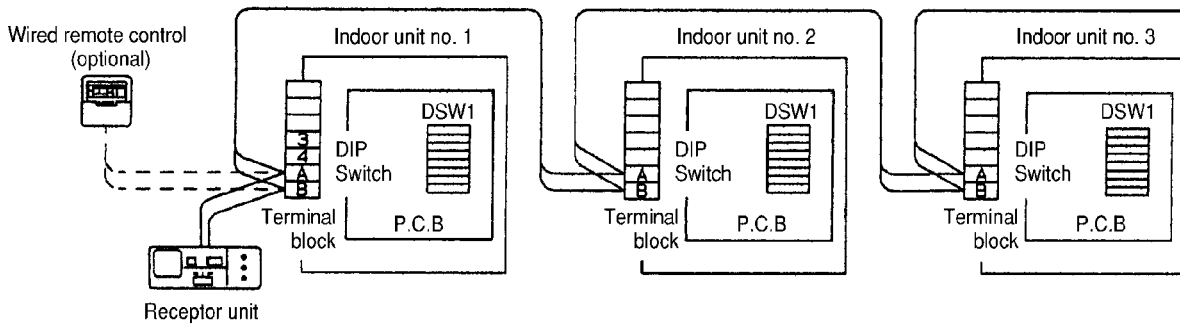

- When using group control, up to a maximum of 16 indoor units can be connected. (Do not mix heat pump units and cooling only units.)
- When using group control, the indoor unit address numbers can be set automatically. However, you will not know at this time which address number corresponds to which indoor unit.
- Setting of address numbers can be carried out manually using the DIP switches. Manual settings have priority. (Do not combine both manual settings and automatic settings.)

[Manual Setting]

Indoor unit No.	1	2	3	4	5	6	7	8
DIP switch (DSW1) address setting on indoor unit printed circuit board.								
A/C No. setting	Unnecessary operation	1 ~ ON	2 ~ ON	1, 2 ~ ON	3 ~ ON	1, 3 ~ ON	2, 3 ~ ON	1, 2, 3 ~ ON
Indoor unit No.	9	10	11	12	13	14	15	16
DIP switch (DSW1) address setting on indoor unit printed circuit board.								
A/C No. setting	4 ~ ON	1, 4 ~ ON	2, 4 ~ ON	1, 2, 4 ~ ON	3, 4 ~ ON	1, 3, 4 ~ ON	2, 3, 4 ~ ON	1, 2, 3, 4 ~ ON

NOTE

The OFF/ON setting position for DIP switch No. 7 (louvre) will vary depending on the model.

5. Test mode operation

- Press the TEST RUN switch within 1 minute of pressing the OFF/ON switch.
 - If more than 1 minute elapsed test operation will not commence and so you will need to press the OFF/ON switch again and repeat the operation.
 - Use the OPERATION switch to select the operation mode. The mode selected will appear on the operation mode display.
- When test operation starts, "TEST RUN" will appear in the timer display of the LCD. The indoor unit will run in the operation mode indicated at this time (COOL or HEAT).
 - Test mode can be cancelled by pressing the OFF/ON switch, the TEMP, ▲ or ▼ switches, the OPERATION switch, the FAN SPEED switch or TEST RUN switch.

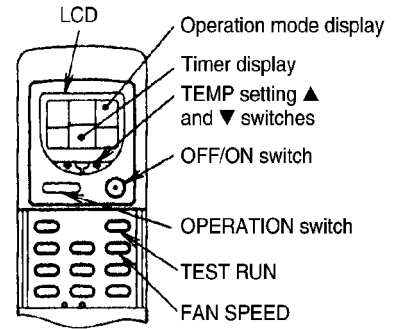

NOTE

- NOTE 1 During test operation, be sure to run the units in cooling mode first. If heating mode is selected first, it may cause problems with operation of the compressor.
- NOTE 2 Test operation should be carried out for a minimum of 5 minutes. (Test operation will be cancelled automatically after 30 minutes.)
- NOTE 3 If using the wireless remote control to carry out test operation, use the wireless remote control to cancel the test operation also.

6. Emergency operation

- If you do not have the wireless remote control (because the batteries are weak, or some other reason preventing the wireless remote control from being used), emergency operation can be carried out at the receptor unit.

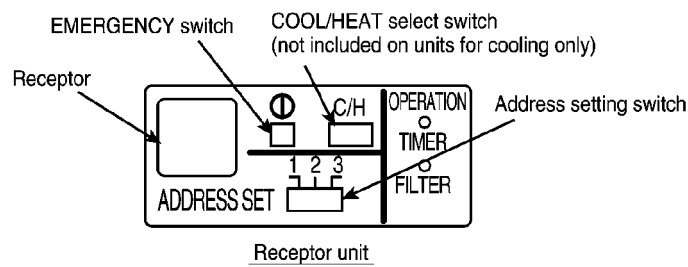

- After setting the COOL/HEAT select switch on the receptor unit to either COOL or HEAT, press the EMERGENCY switch to start emergency operation. Press the EMERGENCY switch once more to stop emergency operation.
- The setting temperature, fan speed and louvre control will be fixed at the settings shown in the table below.

COOL/HEAT select switch	Operation mode	Setting temperature	Fan speed	Louvre
COOL	Cooling	22°C	MED	Automatic
HEAT	Heating	28°C	MED	Automatic

- While the indoor unit is running, the OPERATION indicator on the receptor unit will illuminate, and it will switch off when the indoor units stops.
- Heating operation is not available for indoor units which are for cooling only. (If set to HEAT, the setting will change to FAN instead).

Instructions for users

Please refer to the instruction manual provided with the indoor unit for instruction on how to use the wireless remote control.

29 INSTALLATION (INDOOR UNIT)



CEILING TYPE AIR CONDITIONERS INSTALLATION INSTRUCTIONS

REFRIGERANT
R 407C

HP	Model Name
2 HP	CS-W18BTP
2.5 HP	CS-W24BTP
3 HP	CS-W28BTP
4 HP	CS-W34BTP
5 HP	CS-W43BTP
6 HP	CS-W50BTP

Precautions in terms of safety

Carry out installation work with reliability after thorough reading of this "Precautions in terms of safety".

- Precautions shown here are differentiated between  Warnings and  Cautions. Those that have much chances for leading to significant result such as fatality or serious injury if wrong installation would have been carried out are listed compiling them especially into the column of  Warnings.

However, even in the case of items which are listed in the column of , such items also have a chance for leading to significant result depending on the situations.

In either case, important descriptions regarding the safety are listed, then observe them without fail.

- As to indications with illustration

 This mark means "Caution" or "Warning".

 This mark means "Earth".

- After installation work has been completed, do not only make sure that the unit is free from any abnormal condition through the execution of try run but also explain how to use and how to perform maintenance of this unit to the customer according to the instruction manual.

In addition, request the customer to keep this manual for installation work together with instruction manual.

 Warnings
▲ The appliance must be installed by technician, who takes into account the requirements given by ISO5149 or eventual equivalent requirements.
▲ As to installation, request the distributor or vendor to perform it. Imperfection in installation caused by that having been carried out by the customer himself may lead to water leakage, electric shock, fire, etc.
▲ Carry out the installation work with reliability according to this manual for installation work. Imperfection in installation leads to water leakage, electric shock, fire, etc.
▲ Carry out the installation work with reliability on the place that can bear the weight of this unit sufficiently. Insufficient strength leads to injury due to falling of the unit.
▲ Carry out predetermined installation work in preparation for strong wind such as typhoon, earthquake. Imperfection in installation work may lead to accidents arisen from overturn, etc.
▲ The unit must be installed in accordance with applicable national and local regulations. Any electrical work should only be carried out by qualified technician and use exclusive circuits without fail. Presence of insufficient capacity in power circuit or imperfection in execution leads to electric shock, fire, etc.
▲ Wiring shall be connected securely using specified cables and fix them securely so that external force of the cables may not transfer to the terminal connection section. Imperfect connection and fixing leads to fire, etc.

 Warnings
▲ If installing inside a small room, measures should be taken to prevent refrigerant levels from building up to critical concentrations in the event of a refrigerant leak occurring. Please discuss with the place of purchase for advice on what measures may be necessary to prevent critical concentrations being exceeded. If the refrigerant leaks and reaches critical concentration levels, there is the danger that death from suffocation may result.
▲ Securely attach the protective covers for the outdoor unit connection cables and power cord so that they do not lift up after installation. If the covers are not properly attached and installed, the terminal connections may overheat, and fire or electric shock may result.
▲ Switch off all supplies before accessing any electrical part.
▲ If refrigerant gas escapes during installation, ventilate the affected area. If the refrigerant gas comes into contact with sparks or naked flames, it will cause toxic gases to be generated.
▲ Once installation work is completed, check that there are no refrigerant gas in the room that can come into contact with sparks or flames from a fan heater, stove kitchen range, which will cause toxic gases to be generated.
▲ When performing piping work do not mix air except for specified refrigerant (R407C) in refrigeration cycle. It causes capacity down, and risk of explosion and injury due to high tension inside the refrigerant cycle.

⚠ Cautions



- ▲ Carry out Earthing work.
Do not connect the Earth return to the gas pipe, water line pipe, lightning rod and telephone lines.
Imperfection in Earth return may lead to electric shock.
- ▲ Do not install the unit at the place where the possibility of inflammable gas leakage exists. If such gas leakages should arise and the gas builds up around the unit, such situation may lead to ignition.
- ▲ Mounting of the earth leakage circuit breaker is required. Omission in mounting of the earth leakage circuit breaker may lead to electric shock.



⚠ Cautions

- ▲ Drain piping should be made to ensure secure drainage according to the manual for installation work and carry out the thermal insulation to prevent the occurrence of condensation.
Imperfection in piping work lead to water leakage and may cause the house and property, etc. to become wet.
- ▲ Position the indoor unit and outdoor unit, power cords and indoor/outdoor unit connection cables in a way so that they are at least 1 meter away from televisions and radios.
This is to avoid problems such as interference with picture and/or sound. (However, note that depending on the electromagnetic wave conditions, interference may still occur even if the separation distance is more than 1 meter.)

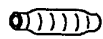
1. ACCESSORIES PACKED IN THE INDOOR UNIT CONTAINER

Name	Q'ty	Appearance	Purpose	Name	Q'ty	Appearance	Purpose
Band	2		For fastening the heat insulator	Drain hose	1		For drain piping
Edge protection cover	1		To protect the end surface of the piping holes	Heat insulator	1		For insulating refrigerant pipe joint

2. SELECTING THE LOCATION FOR THE INDOOR UNIT

Provide a check port on the piping side ceiling for repair and maintenance.

- Install the indoor unit once the following conditions are satisfied and after receiving the customers approval.
 1. The indoor unit must keep a maintenance space.
 2. The indoor unit must be free from any obstacles in path of the air inlet and outlet, and must allow spreading of air throughout the room.

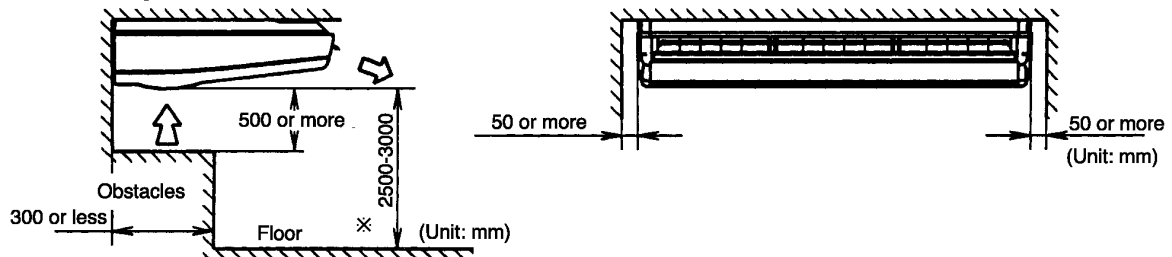

⚠ Warnings

3. The installation position must be able to support a load four times the indoor unit weights.
4. The installation location (surface that the unit is suspended from) must be horizontal (and guaranteed to stay horizontal).
5. The indoor unit must be away from heat and steam sources, but avoid installing it near an entrance.
6. The indoor unit must allow easy draining.
7. The indoor unit must allow easy connection to the outdoor unit.
8. The indoor unit must be at least 3 m away from any noise-generating equipment. The electrical wiring must be shielded with a steel conduit.
9. If the power supply is subject to noise generation, add a suppressor.
10. Do not install the indoor unit at a laundry. Electric shocks may result.

NOTE

- Study thoroughly the following installation locations

- In places such as restaurants and kitchens, considerable amount of oil steam and flour adhere to the fan, and the fin of the heat exchanger may result in heat exchange reduction, spraying or dispersing of water drops, etc. In these cases, take the following actions:
 - Make sure the ventilation fan for smoke-collection hood on a cooking table has sufficient capacity so that it draws oily steam which should not flow into the suction of the air conditioner.
 - Make enough distance from cooking room to install the air conditioner in such place where it may not suck in oily steam.

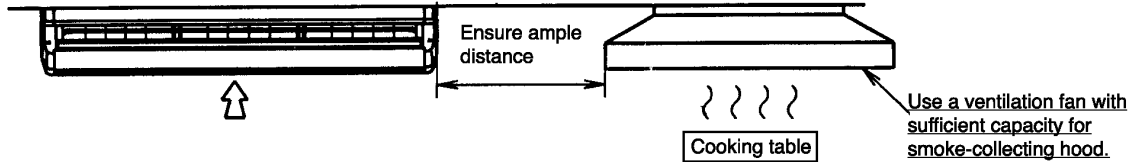

- Avoid installing the air conditioner in such circumstances where cutting oil mist or iron powder exist especially in factories, etc.
- Avoid places where inflammable gas can be generated, flows-in, contaminated, or leak.
- Avoid places where sulphurous acid gas or corrosive gas can be generated.
- Avoid places near high frequency generators.

3. INSTALLATION OF INDOOR UNIT

The paper template for installation may expand or shrink according to temperature and humidity. Check the dimensions before using it.

CEILING OPENING DIMENSIONS AND HANGING BOLT LOCATION

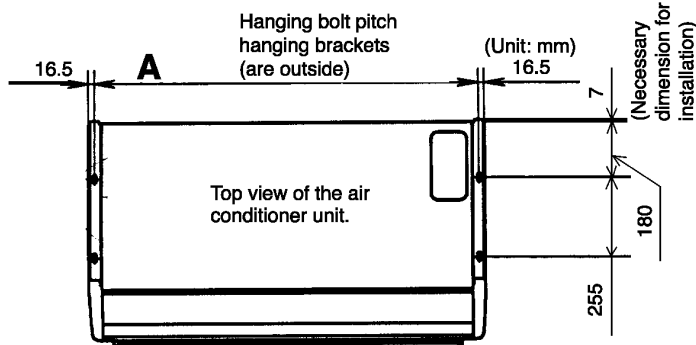

Keep the length of the bolt from the bracket 25 to 70 mm

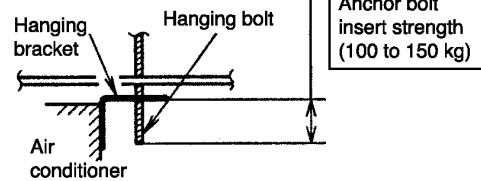

(Unit: mm)

Model Name		A
CS-W18BTP	CS-W24BTP	1212
CS-W28BTP		
CS-W34BTP	CS-W43BTP	1567
CS-W50BTP		

Caution During the installation, care must be taken not to damage the electric wires.

REMOVING THE SIDE COVER AND HANGING BRACKET

- Open the inlet grille, and remove the side cover fixing screw (right and left) from the internal part of the unit.
- Move the side cover to about 15 mm forward to remove it.
Use the packing material (Styrene foam) to support, when you reverse the top and bottom of the indoor unit.
- Remove the hanging bracket
 - 1) Remove the slip prevention screws of the brackets (right and left).
 - 2) Loosen the hanging bracket fastening bolts to about 10 mm, and remove the hanging bracket.

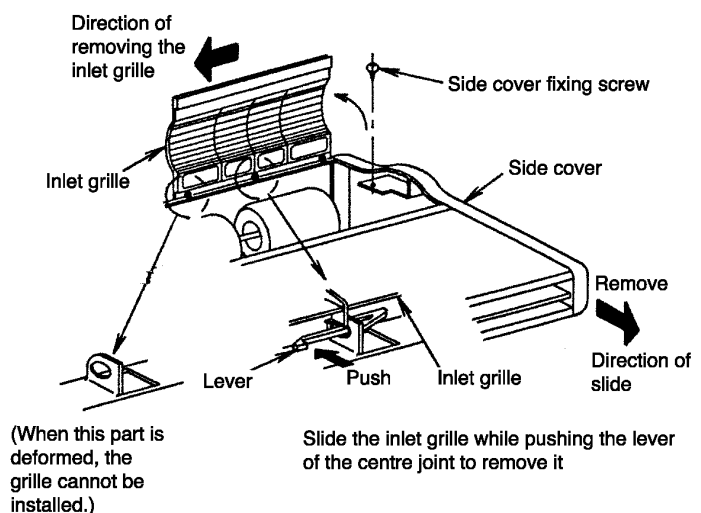

Fastening the hanging bracket

※ Use either W3/8 or M10 bolts and nuts (locally supplied)

● Fastening the hanging bracket

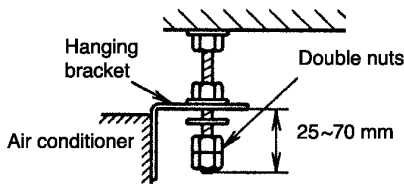

Slip prevention screw (M5)

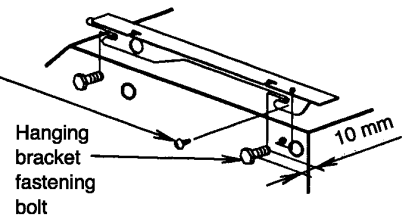

Caution: For safety, you must use washers and double nuts to ensure a secure installation.



Warning Be sure to tighten the nut and bolt to prevent the unit from falling.

Piping hole positions

- The refrigerant piping can be installed on the right, right upper or right rear.
- The drain piping can be installed on the right, right rear, left or left rear (there are connection ports on both right and left sides.)
- Thermally insulate the drain and refrigerant piping to prevent dew condensation.
- After cutting the piping holes, use the edge protection cover (accessory) to protect the end surfaces.

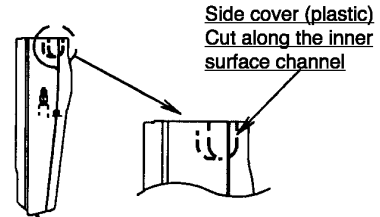
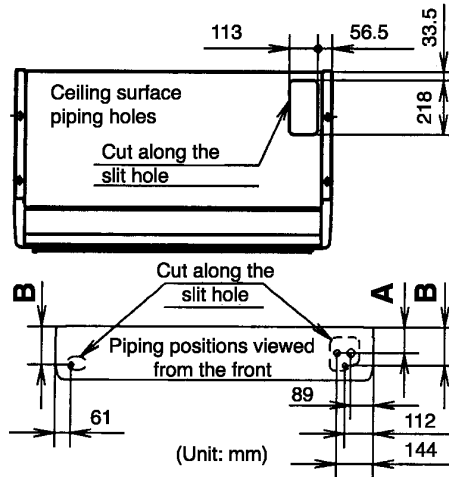

Model Name	A	B
CS-W18BTP		
CS-W24BTP	101	151
CS-W28BTP		
CS-W34BTP	141	191
CS-W43BTP		
CS-W50BTP		

Installing the unit

1. Insert the hanging bracket fastening bolts and both sides of the unit into the hanging brackets, and slide the unit to the rear. Fasten the bolts.
2. Tighten the slip prevention screws (M5) for brackets to prevent the unit from shifting.
3. To ensure correct drainage, after hanging the unit, use a level gauge to check the installation angle.

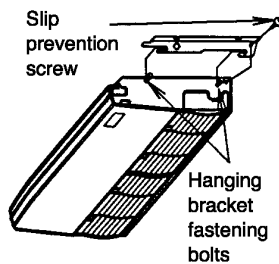

When the drain piping is connected to the right side



- The unit should be level, or the back right should be inclined down. (Within one degree)

When the drain piping is connected to the left side

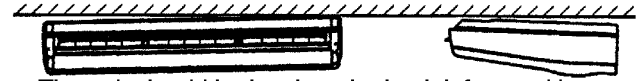

- The unit should be level, or the back left sound be inclined down. (Within one degree).

4. REFRIGERANT PIPING

Refrigerant is charged to the outdoor unit.
For details, see the manual for installation work of outdoor unit.
(Additional charging, etc.)

1. Brazing for piping.
 - a. Perform brazing before tightening the flare nut.
 - b. Brazing must be performed while blowing nitrogen gas.
(This prevents generation of oxidized scale in copper pipe.)
2. When there is a lot of brazing for long piping, install a strainer at the midway of the piping.
(The strainer is locally supplied.)
3. Use clean copper pipe with inner wall surface free from mist and dust. Use nitrogen gas or air to blow off dust in the pipe before connection.
4. Form the piping according to its routing. Avoid bending and bending back the same piping point more than three times.
(This will result in hardening of the pipe).
5. After deforming the pipe, align centres of the union fitting of the indoor unit and the piping and tighten them firmly with wrenches.
6. Connect pipe to the service valve or ball valve which is located below the outdoor unit.
7. After completing the piping connection, be sure to check if there is gas leakage in indoor and outdoor connection.

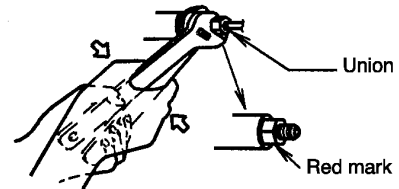

- Confirm the red mark of the union (thin side) is always at lower direction after connecting piping.

Vacuum drying

After completing the piping connection, perform vacuum drying for the connecting piping and the indoor unit.
The vacuum drying must be carried out by using the service ports of both the liquid and gas side valves.

CAUTION Use two wrenches and tighten with regular torque.

Flare nut fastening torque N·m (kgf·cm)			
ø6.35 mm	18 (180)	ø15.88 mm	65 (660)
ø9.52 mm	42 (430)	ø19.05 mm	100 (1020)
ø12.7 mm	55 (560)		

Model Name	Liquid side piping	Gas side piping
CS-W18BTP	ø6.35 mm	ø12.7 mm
CS-W24BTP	ø6.35 mm	ø15.88 mm
CS-W28BTP	ø9.52 mm	ø15.88 mm
CS-W34BTP	ø9.52 mm	ø19.05 mm
CS-W43BTP		
CS-W50BTP		

5. INDOOR UNIT DRAIN PIPING

- Be sure to use the drain hose provided (accessory item.)
- Drain piping must have down-slope (1/50 to 1/100): be sure not to provide up and down-slope to prevent reversal flow.
- During drain piping connection, be careful not to exert extra force on the drain port at the indoor unit.
- The outside diameter of the drain connection at the indoor unit is 20 mm.

Piping material: Polyvinyl chloride pipe VP-20 and pipe fittings

Heat insulation material: Polyethylene foam with thickness more than 8 mm

Caution Be sure to perform heat insulation on the drain piping.
If insulation is insufficient, dew may form.
This causes water leakage.

Caution Prevent the drain hose from floating and hanging down.
This causes water leakage. (right figure)

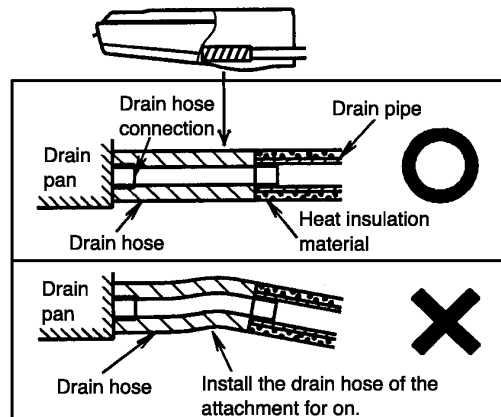
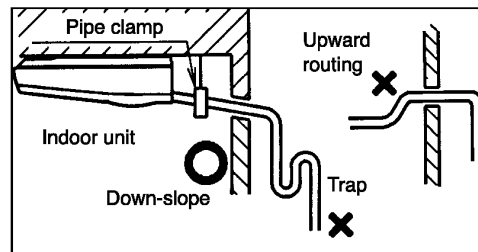

In the case of left piping

1. Remove both the internal and external plugs.
2. Use a wrench or pliers to remove the plugs.
 - Putting substitution of rubber plug.

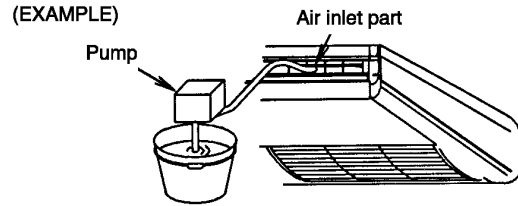
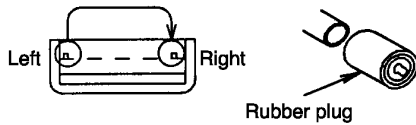

Drain test

Confirm the drain water flows smoothly after connecting the drain piping.

- Pour water to about 1.5 litres for the drainage confirmation from the air inlet part which should gradually flow into the drain pan.

6. HEAT INSULATION



Be sure to perform heat insulation on the drain and gas piping. Imperfection in heat insulation work leads to water leakage.

1. Use the heat insulation material for the refrigerant piping which has an excellent heat-resistance (over 100°C).

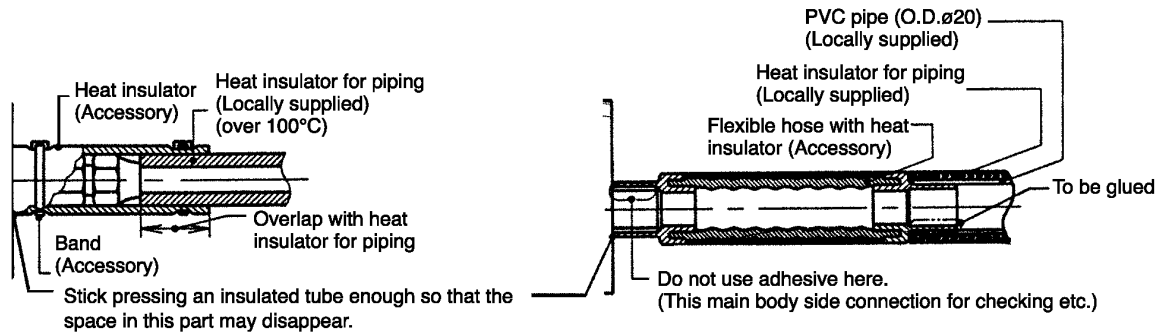

2. Precautions in high humidity circumstance.

This air conditioner has been tested according to the "JIS Standard Conditions with Mist" and confirmed that there is no form of any faults. However, if it is operated for a long time in high humid atmosphere (dew point temperature: more than 23°C), water drops are liable to fall.

- In addition to the normal heat insulation (thickness: more than 8 mm) for refrigerant piping (gas piping: thick piping) and drain piping, add a further of 10 mm to 30 mm thickness material.

Wall seal

- When the outdoor unit is installed at a higher position than the indoor unit, install a trap so as not to instill rain water into the wall transmitted by the piping.
- Stuff the space among piping, the electric wire, and the drain hose with "Putty" and seal the penetration wall hole. Make sure that rain water do not instill into the wall.

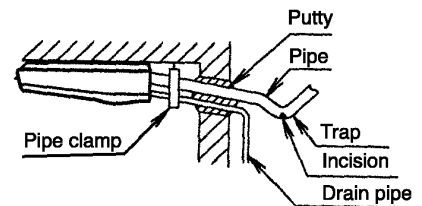

- ※ Put the incision at the trap part of the heat insulator (for water drainage)

7. ELECTRICAL WIRING

As to the main power source and cable size of outdoor unit, read the installation manual attached to the outdoor unit.

<p>⚠ Warning</p>	<p>The units must be connected to the supply cables for fixed wiring by qualified technician. Feed the power source to the unit via a distribution switch board designed for this purpose. The switch should be disconnected at all poles with a contact separation of at least 3 mm. When the supply cable is damaged it must be replaced by qualified technician.</p>
<p>⚠ Caution</p>	<p>Be sure to install a current leakage breaker, main switch and fuse to the main power supply, otherwise electric shocks may result.</p>
<p>⚠ Caution</p>	<p>Be sure to connect the unit to secure earth connection. If the earthing work is not carried out properly, electric shock may result.</p>
<p>⚠ Warning</p>	<p>Wiring shall be connected securely by using specified cables and fix them securely so that external force of the cables may not transfer to the terminal connection section. Imperfect connection and fixing leads to fire, etc.</p>



1. Select a power source that is capable of supplying the current required by the air conditioner.
2. Be sure to connect the wires correctly to terminal board with connecting the crimp tyre ring terminal to the wires.
3. Be sure to turn off the main power before installing and connecting the remote controller.

<p>Note</p>	<p>If momentarily turning on the power supply for both the indoor and outdoor units, do not turn the power off again until at least 1 minute has passed. (for the system automatic setting). Turning off the power supply on the way may cause an abnormal operation.</p>
-------------	---

- Use the standard power cables for Europe (such as H05RN-F or H07RN-F which conforms to CENELEC (HAR) rating specifications) or use the cable based on IEC standard. (245IEC57, 245IEC66)

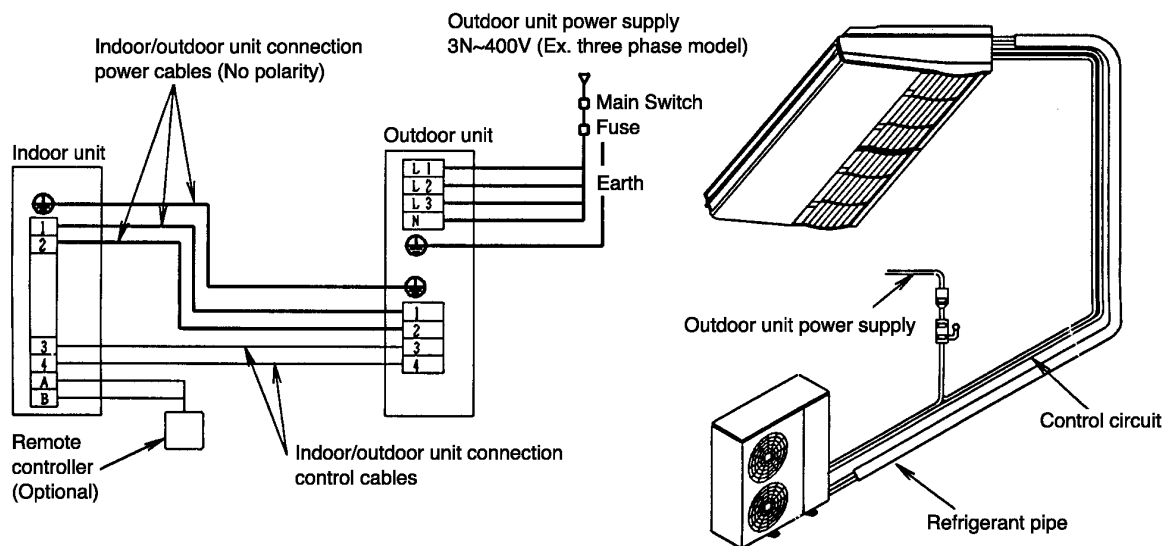

CONNECTING THE WIRES TO THE CONTROL BOX

- Remove two mounting screws, remove the control box cover, and then connect the wires by following the procedure given in the illustration.

Caution Make sure the screws of the terminal are securely tightened.

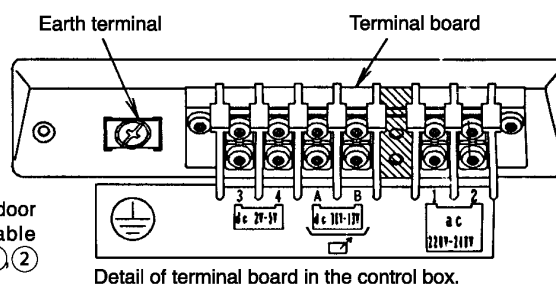
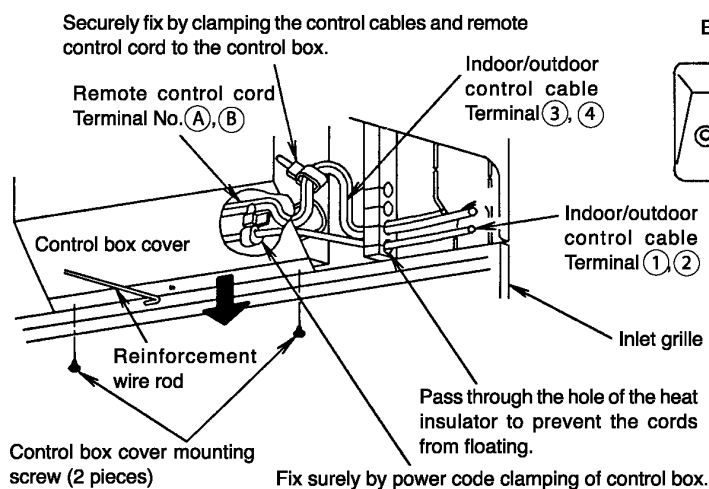

Indoor/outdoor unit connection control cables. The length of the control line can be up to 200 m.

- Route the connection cables apart from the power cables to prevent abnormal operations (noise can be generated).

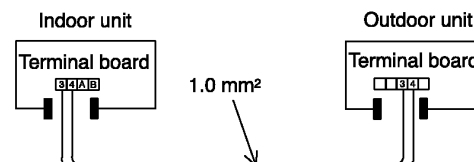

8. SETTINGS

※ Do not operate the remote controller within 1 minute after turning on the power of the indoor unit.

- ※ When using group control with the standard type, at least 1 unit must be set at No.1 at the indoor unit.
- ※ Check the settings of the indoor unit in a case where there are no display at remote controller. If there is no problem to the settings, either group control or standard type should be set at No.16 at the indoor unit before turning the power on again.

Caution Do not connect to Timer Setting, Fan Power (Connector CNT1 on printed circuit board) except when the relay or the circuit board may be broken.

- All sets in the group which uses the same controller thermistor settings can be controlled by the same remote controller thermistor.
- Up to a maximum of 16 indoor units can be connected at the time of group control. (Do not connect heat pump unit with cooling only unit.)
- Indoor unit No. will be set automatically at the time of group control. However, which indoor unit uses which number is unknown.

Indoor unit No. is also possible to be set manually with DIP switches. Since manual address setting has priority to automatic address setting. To perform automatic address setting after doing manual setting, turn off all DIP switches from No.1 to No.4, and then stop the operation. Then press three switches such as [AIR SWING AUTO] • [OPERATION] • [A/C No.] at the same time.

(Do not use manual address setting and automatic address setting together.)

- Centralized control is possible for master unit and slave unit at the time of group control.

Indoor unit No.		1	2	3	4	5	6	7	8
Manual Setting	DIP switch (DSW1) address setting on indoor unit printed circuit board.								
	A/C No, setting	Unnecessary operation	1-ON	2-ON	1, 2-ON	3-ON	1, 3-ON	2, 3-ON	1, 2, 3-ON
	Indoor unit No.	9	10	11	12	13	14	15	16
Manual Setting	DIP switch (DSW1) address setting on indoor unit printed circuit board.								
	A/C No, setting	4-ON	1, 4-ON	2, 4-ON	1, 2, 4-ON	3, 4-ON	1, 3, 4-ON	2, 3, 4-ON	1, 2, 3, 4-ON
	Indoor unit No.	9	10	11	12	13	14	15	16

(Remote Controller address setting)

(Refer to the Installation Manual which is provided with the remote controller for details.)

- Two remote controllers (including the wireless remote controller) can be connected. However, remote control thermistor setting is not possible.
- As for (master/slave) setting of remote controller, the automatic setting and manual settings are possible. Since manual setting has priority.
- Two remote controllers, which both are wireless, cannot be connected.

9. TIMER AND FAN OUTPUT

- Connect the wires from the connector (CNT1) on printed circuit board.

Timer setting

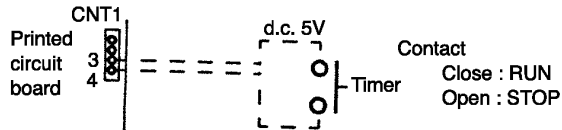

Fan output

(synchronization with fan) d. c. 12V 75mA

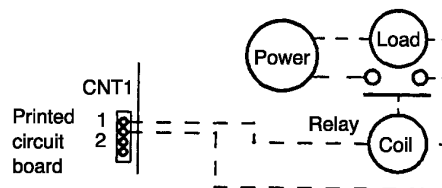

Connect to another circuit contact of the timer.

Connect the timer cord to connector (CNT1 ③, ④) on PCB.

Connect the timer cord to connector (CNT1 ①, ②) on PCB.

10. PRECAUTIONS DURING TEST RUN

- The initial power supply must provide at least 90% of the rated voltage. Otherwise, the air conditioner may not operate.

- Test operation can be carried out using the remote control unit or at the outdoor unit. (If carrying out test operation at the outdoor unit, refer to "TEST OPERATION" in the outdoor unit installation manual.)
- If using the remote control unit to carry out test operation, follow the procedure given below.

- First, press the OFF/ON (⊙) button.



TEST RUN



- Then press the TEST RUN button within 1 minute of pressing the OFF/ON (⊙) button.

- Next, select the operation modes.

- The temperature of the indoor unit pipes will be shown on the temperature setting display. (At the start of the test operation, it may take up to 1 minute for air conditioner number, switching time and other displays to appear.)

- After operation modes have been selected, stop the compressor for a moment.

- Press the OFF/ON (⊙) button of the TEST RUN button once more to cancel test operation mode.

NOTE 1 These units are equipped with connection error prevention circuits. If the units do not operate, it is possible that the connection error prevention circuits have operated. In such cases, check that the power wires (connected to terminals ① and ②) and the control wires (connected to terminals ③ and ④) are connected correctly. If they are connected incorrectly, connect them correctly. Normal operation should then commence.

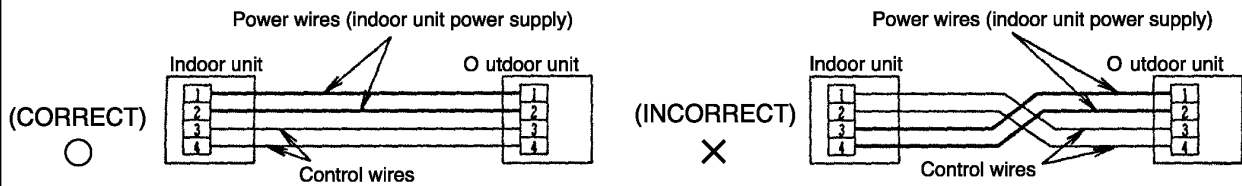

NOTE 2 Do not short the remote control unit wires to each other. (The protection circuit will be activated and the units will not operate.) Once the cause of the short is eliminated, normal operation will then be possible.

NOTE 3 When running the units in heating mode during test operation, be sure to run the units in cooling mode first before selecting this mode. If heating mode is selected first, it may cause problems with operation of the compressor. (Heat pump model only.)

NOTE 4 Test operation should be carried out for a minimum of 5 minutes. (Test operation will be cancelled automatically after 30 minutes.)

NOTE 5 Test operation mode should always be cancelled once test operation itself has been completed.

11. CHECK THE FOLLOWING ITEMS WHEN INSTALLATION IS COMPLETE

- After completing work, be sure to measure and record trial run properties, and store measuring data, etc.
- Measuring items are room temperature, outside temperature, suction temperature, blow out temperature, wind velocity, wind volume, voltage, current, presence of abnormal vibration and noise, operating pressure, piping temperature, compressive pressure, airtight pressure.
- As to the structure and appearance, check the following items.

<input type="checkbox"/> Is circulation of air adequate? <input type="checkbox"/> Is draining smooth? <input type="checkbox"/> Is heat insulation complete (refrigerant and drain piping)? <input type="checkbox"/> Is there any leakage of refrigerant?	<input type="checkbox"/> Is remote controller switch operated? <input type="checkbox"/> Is there any faulty wiring? <input type="checkbox"/> Are the terminal screws loosened? M3...69-98N·cm {7-10kgf·cm} M4....157-196N·cm {16-20kgf·cm} M5...196-245N·cm {20-25kgf·cm}
---	---

12. HAND OVER

- Teach the customer the operation and maintenance procedures, using the operation manual (air filter cleaning, temperature control, etc.)

As to parts to be sold separately

- With regards to installation of the parts sold separately, follow the installation manual which is provided with the parts sold separately.

As for work specifications of the outdoor unit, read the OUTDOOR UNIT INSTALLATION MANUAL attached to the outdoor unit.

30 INSTALLATION (OUTDOOR UNIT)



AIR CONDITIONERS OUTDOOR UNIT INSTALLATION INSTRUCTIONS

REFRIGERANT
R 407C

HP	Model Name	
2 HP	CU-W18BBP5	CU-V18BBP5
2.5 HP	CU-W24BBP5	CU-V24BBP5 CU-V24BBP8
3 HP	CU-W28BBP5 CU-W28BBP8	CU-V28BBP5
4 HP	CU-W34BBP8	CU-V34BBP8
5 HP	CU-W43BBP8	CU-V43BBP8
6 HP	CU-W50BBP8	CU-V50BBP8

Precautions in terms of safety

Carry out installation work with reliability after thorough reading of this "Precaution in terms of safety".

- Precautions shown here are differentiated between  Warnings and  Cautions. Those that have much chances for leading to significant result such as fatality or serious injury if wrong installation would have been carried out are listed compiling them especially into the column of .

However, even in the case of items which are listed in the column of , such items also have a chance for leading to significant result depending on the situations.

In either case, important descriptions regarding the safety are listed, then observe them without fail.

- As to indications with illustration

 This mark means "Caution" or "Warning".

 This mark means "Earth".

- After installation work has been completed, do not only make sure that the unit is free from any abnormal condition through the execution of trial run but also explain how to use and how to perform maintenance of this unit to the customer according to the instruction manual.

In addition, request the customer to keep this manual for installation work together with instruction manual.



Warnings

▲ The appliance must be installed by technician, who takes into account the requirements given by ISO5149 or eventual equivalent requirements.	technician and use exclusive circuits without fail. Presence of insufficient capacity in power circuit or imperfection in execution leads to electric shock, fire, etc.
▲ As to installation, request the distributor or vendor to perform it. Imperfection in installation caused by that having been carried out by the customer himself may lead to water leakage, electric shock, fire, etc.	▲ Wiring shall be connected securely using specified cables and fix them securely so that external force of the cables may not transfer to the terminal connection section. Imperfect connection and fixing leads to fire, etc.
▲ Carry out the installation work with reliability according to this manual for installation work. Imperfection in installation leads to water leakage, electric shock, fire, etc.	▲ If installing inside a small room, measures should be taken to prevent refrigerant levels from building up to critical concentrations in the event of a refrigerant leak occurring. Please discuss with the place of purchase for advice on what measures may be necessary to prevent critical concentrations being exceeded. If the refrigerant leaks and reaches critical concentration levels, there is the danger that death from suffocation may result.
▲ Carry out the installation work with reliability on the place that can bear the weight of this unit sufficiently. Insufficient strength leads to injury due to falling of the unit.	▲ Securely attach the protective covers for the outdoor unit connection cables and power cord so that they do not lift up after installation. If the covers are not properly attached and installed, the terminal connections may overheat, and fire or electric shock may result.
▲ Carry out predetermined installation work in preparation for strong wind such as typhoon, earthquake. Imperfection in installation work may lead to accidents arisen from overturn, etc.	▲ Switch off all supplies before accessing any electrical part.
▲ The unit must be installed in accordance with applicable national and local regulations. Any electrical work should only be carried out by qualified	

⚠ Warnings	⚠ Cautions
<p>▲ If refrigerant gas escapes during installation, ventilate the affected area. If the refrigerant gas comes into contact with sparks or naked flames, it will cause toxic gases to be generated.</p>	<p>▲ Carry out Earthing work. Do not connect the Earth return to the gas pipe, water line pipe, lightning rod and telephone lines. Imperfection in Earth return may lead to electric shock.</p> 
<p>▲ Once installation work is completed, check that there are no refrigerant gas in the room that can come into contact with sparks or flames from a fan heater, stove or kitchen range, which will cause toxic gases to be generated.</p>	<p>▲ Do not install the unit at the place where the possibility of inflammable gas leakage exists. If such gas leakages should arise and the gas builds up around the unit, such situation may lead to ignition.</p>
<p>▲ When performing piping work do not mix air except for specified refrigerant (R407C) in refrigeration cycle. It causes capacity down, and risk of explosion and injury due to high tension inside the refrigerant cycle.</p>	<p>▲ Mounting of the earth leakage circuit breaker is required. Omission in mounting of the earth leakage circuit breaker may lead to electric shock.</p>
	<p>▲ Drain piping should be made to ensure secure drainage according to the manual for installation work and carry out the thermal insulation to prevent the occurrence of condensation. Imperfection in piping work leads to water leakage and may cause the house and property, etc. to become wet.</p>
	<p>▲ Position the indoor unit and outdoor unit, power cords and indoor/outdoor unit connection cables in a way so that they are at least 1 metre away from televisions and radios. This is to avoid problems such as interference with picture and/or sound. (However, note that depending on the electromagnetic wave conditions, interference may still occur even if the separation distance is more than 1 metre.)</p>

1. ACCESSORIES SUPPLIED WITH OUTDOOR UNIT

- The following parts are supplied as accessories with each outdoor unit. Check that all accessory parts are present before installing the outdoor unit.

Part name	Q'ty	Diagram	Application
Protective bushing	2		For protecting electrical wires
Banding strap	3		For tying electrical wires together

Heat pump-types only			
Part name	Q'ty	Diagram	Application
Drain elbow AS	1		For connecting the drain pipe (with ring seat)

2. BEFORE INSTALLATION WORK

- This product is using new refrigeration (R407C). The basic way of installation work is the same as usual, but water and impurities should be controlled more strictly than before due to characteristic of refrigerating machine oil. Therefore, selection of materials to use and processing, storing and brazing need appropriate construction and control.

1. Tools and materials.

There are tools and materials for both new refrigeration and usual refrigeration you can use together and for either two of them you can use. Use the below for new refrigeration.

- Vacuum pump (with back flow preventor system)
- Gas leakage detection warning device
- Gauge manifold
- Charge hose

2. Installation work

① Brazing work

Brazing work needs replacing air inside pipe with nitrogen gas in order to prevent oxidization scale from occurring. This is called nitrogen replacement, and one of very important work in brazing refrigerant piping. (Oxidation preventive is not possible to use)

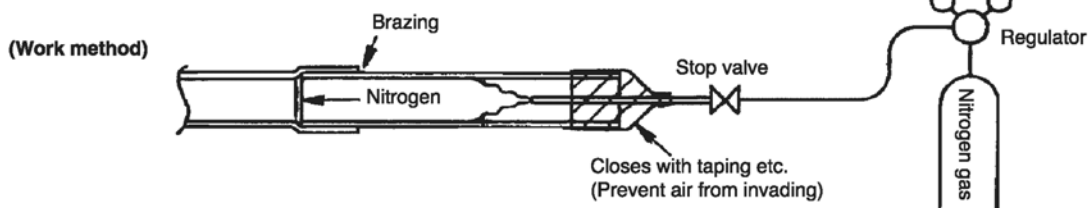

- ② Prevention measure for refrigerant piping
Prevention measure for refrigerant piping is very important work to prevent water-dust-rubbish from getting in. All piping terminals needs sealing such as shown below.

Place	Period of work	Method of seal
Outside	More than 1 month	Pinch
	Less than 1 month	Pinch or taping
Inside	Not specified	

- How to pinch
Close terminal part of piping with pliers and seal the gap with brazing.
- How to tape
Seal terminal part of piping with vinyl tape.

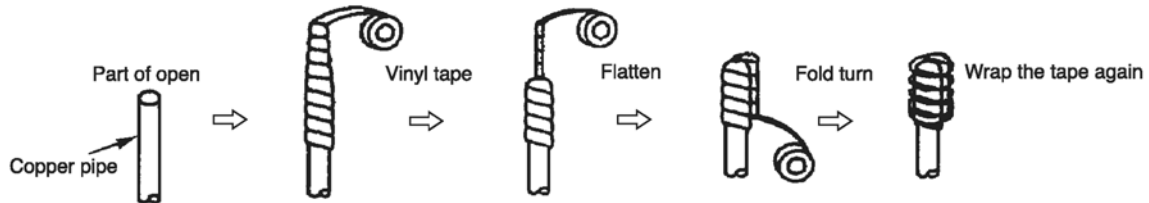
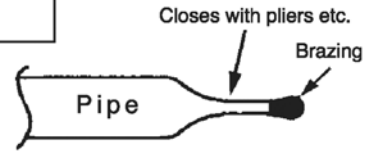

3. Vacuum pumping

The purpose of vacuum pumping work is to remove and dry air inside the piping or nitrogen at air tightness test. Perform the work carefully.

⚠ Caution Use the vacuum pump with the backflow prevention mechanism to prevent backflow of oil.

Vacuumping time 60 minutes or more

⚠ Vacuum pump capacity
60 l/min or more

4. Refrigerant filling

Refrigerant filling must be done in the state of liquid refrigerant. If this is done in gas refrigerant, the balance of refrigerant composition will collapse and damage the operation.

For the use of a gas cylinder without siphon inside, turn it upside down and use it.
(We recommend manifold with sight glass.)

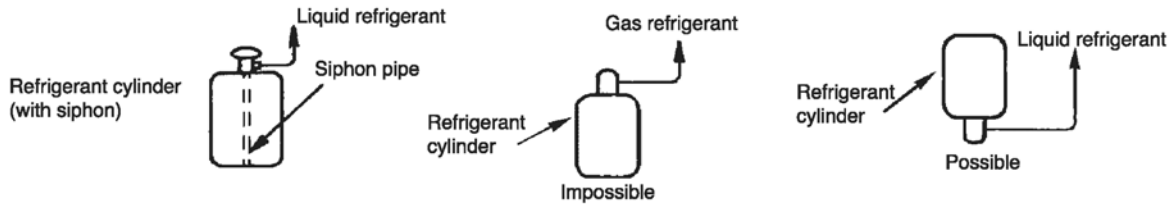

CAUTION Do not use a "CHARGE CYLINDER".

⚠ Caution

As a rule, please collect all existing refrigerants in the system outside the system when the refrigerant leakage occurs by the system.
After that, please fill new refrigerant of a regulated amount again.

3. SELECTING THE OUTDOOR UNIT INSTALLATION LOCATIONS

- Select location which satisfies the following condition, and then confirm with the customer that such a place is satisfactory before installing the outdoor unit.

1. There should be sufficient ventilation.
2. The outdoor unit should be sheltered as much as possible from rain and direct sunlight, and the air should be able to move around so that hot and cold air do not build up.
3. There should not be animals or plants near the air outlet which could be adversely affected by hot or cold air coming out from the unit.
4. The outlet air and operating noise should not be a nuisance to other occupants nearby.
5. The location should be able to withstand the full weight and vibration of the outdoor unit, and it should also be level and safe for the unit to be installed.
6. The intake and outlet should not be covered.
7. There should not be danger of flammable gas or corrosive gas leaks.
8. There should be as little back-ventilation (air blowing directly onto the fan) as possible.
(If strong wind blows directly onto the fan, it may cause problems with normal operation.)

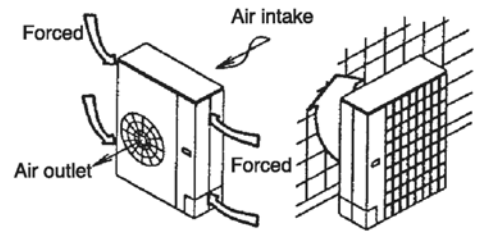

- If you know which direction the prevailing wind comes from during the operating season, set the outdoor unit at a right-angle to this wind direction, or so that the air outlet faces toward a wall or fence.
 - If there are obstructions near the outdoor unit and the wind direction is not constant, install an optional air guider.
9. Do not allow any obstacles near the outdoor unit which will interfere with air flow around the air intake and air outlet.
 10. If installing in a location which is prone to snowfall, place the installation base as high as possible, and be sure to install a roof or enclosure which does not allow snow to accumulate.
 11. Avoid installing the unit in places where petroleum products (such as machine oil), salinity, sulphurous, gases or high-frequency noise are present.
 12. Be sure to leave enough space around the outdoor unit to maintain proper performance and to allow access for routine maintenance.
 - Allow enough space from any obstacles as shown in Fig.1.2 below in order to prevent short-circuits from occurring.
(If installing more than one outdoor unit, make the necessary space available as outlined in 14.)
However, there should be at least 1 metre of free space above the unit.
 - The height of any obstacles at the air intake and outlet sides should not be greater than the height of the outdoor unit.

- When facing the air intake side toward a wall.

- When facing the air outlet side toward a wall.

- When using an optional air guider for outdoor units.

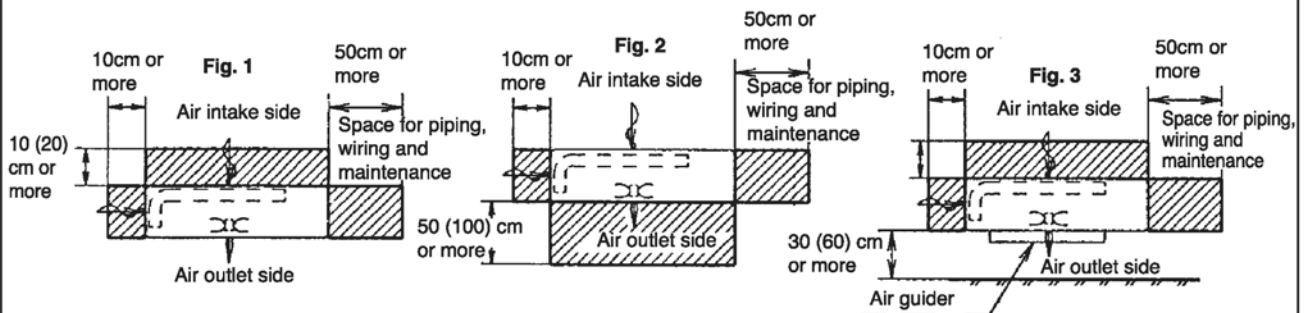

* Maintain sufficient space above the unit.

13. If it is not possible to leave 50 (100)cm at the air outlet side as shown in Fig. 2, the installation method shown in Fig. 3 can be used if an optional air guider for outdoor units is installed. Install according to the instructions given in the separate instruction manual.

NOTE

When installing the air guider

- 1) If directing the air upward, there should not be obstacles above the outdoor unit.
- 2) If directing the air to the left or right, there should not be obstacles at the left or right of the outdoor unit.
- 3) Never use the air guider in locations which are subject to snowfall.
If snow gets inside the air guider, it could cause the fan to freeze up.
- 4) If connecting outdoor units in series, direct the flow upward.

Air guider for outdoor units

Model Name		Part No.
CU-W18BBP5	CU-V18BBP5	CZ-UF01P
CU-W24BBP5	CU-V24BBP5	
	CU-V24BBP8	
CU-W28BBP5	CU-V28BBP5	
CU-W28BBP8	CU-V28BBP8	

Model Name		Part No.
CU-W34BBP8	CU-V34BBP8	CZ-UF01P (2 sets)
CU-W43BBP8	CU-V43BBP8	
CU-W50BBP8	CU-V50BBP8	

14. If installing more than one outdoor unit, allow enough space around each unit as shown below.

• When installing units side by side

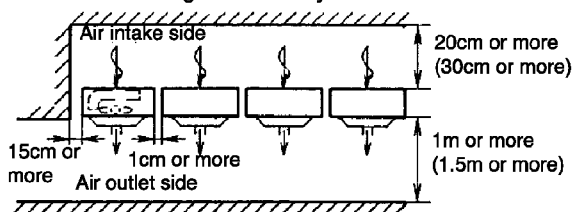

• When installing units facing each other

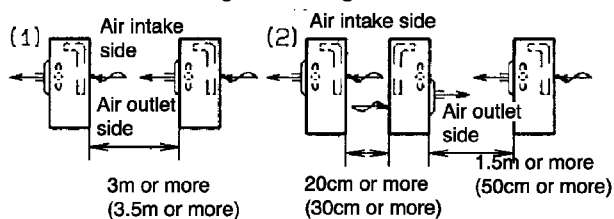

50cm or more (1m or more)
When air guider is installed (direct air flow upward)

1m or more (1.5m or more)
When air guider is installed (direct air flow upward)

50cm or more (1m or more)
When air guider is installed (direct air flow upward)

* Maintain sufficient space above the unit.

Values inside brackets indicate distances when installing the 4HP-5HP.

- The distance given above are the minimum distance required in order to maintain proper performance.
Allow as much space as possible in order to get the best performance from the units.

4. TRANSPORTING AND INSTALLING THE OUTDOOR UNIT

• Transporting

1. The outdoor unit should be transported in its original packaging as close to the installation location as possible.
2. If suspending the outdoor unit, use a rope or belt, and use cloth or wood as padding in order to avoid damaging the unit.
3. Use the handles at left and right to transport the unit, and be careful not to touch your hands or other objects against the fan.

● Installation

1. Read the "Selecting the outdoor unit installation location" section thoroughly before installing the outdoor unit.

2. If installing the unit to a concrete base or other solid base, use M10 or W3/8 bolts and nuts to secure the unit, and ensure that the unit is fully upright and level.
(The anchor bolt positions are shown in the diagram at the right side.)

In particular, install the unit at a distance from the neighbouring building which conforms to regulations specified by local noise emission regulation standards.

3. Do not install the outdoor unit to the building's roof.

4. If there is a possibility that vibration may be transmitted to the rooms of the building, place rubber insulation between the unit and the installation surface.

5. Drain water will be discharged from the outdoor unit when operating the system in heating or defrosting modes. Select an installation location which will allow the water to drain away properly, or provide a drainage channel so that the water can drain away.

(If this is not done, the drain water may freeze during winter, or the water may spill down to areas underneath the installation location.)

* If a drain pipe needs to be installed, insert the accessory drain elbow into the mounting hole at the bottom of the outdoor unit, and connect a hose with an inside diameter of 15mm to this drain elbow.
(The hose is not supplied.)

* If using the drain elbow, install the outdoor unit on a base which is at least 5cm high.

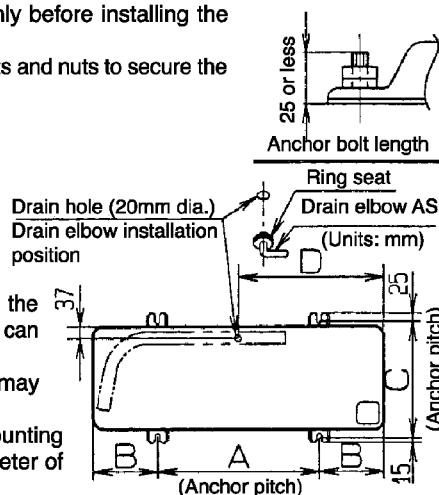

NOTE In cold regions (where the outdoor air temperature can drop to 0°C or below continuously for 2-3 days), the drain water may freeze, and this may prevent the fan from operating. Do not use the drain elbow in such cases.

Model Name		Amm	Bmm	Cmm	Dmm
CU-W18BBP5	CU-V18BBP5	500	200	360	450
CU-W24BBP5	CU-V24BBP5				
CU-W28BBP5	CU-V28BBP5	700	200	360	720
CU-W28BBP8	CU-V28BBP8				
CU-W34BBP8	CU-V34BBP8	700	200	360	720
CU-W43BBP8	CU-V43BBP8				
CU-W50BBP8	CU-V50BBP8				

CAUTION

- Be sure to remove the compressor fixing brackets.
(Some models are not equipped with compressor fixing brackets.)
- To remove, first remove the mounting screws, loosen the compressor mounting nuts and then pull sideways.
- After removing, be sure to tighten the compressor mounting nuts again.

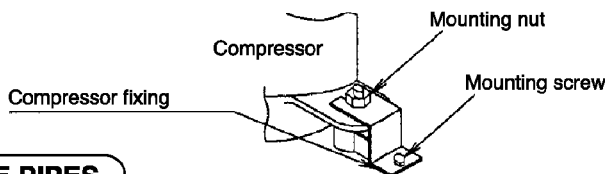

5. CONNECTING THE PIPES

- Use a clean pipe which does not include water or dust for inside of piping.
- When cutting the refrigerant pipes, a piping cutter must be used. Before connecting the refrigerant pipes, blow nitrogen and blow off dust in the pipes.
(Never use tools which cause a lot of dust such as a saw and a magnet.)
- When waxing replace nitrogen inside the piping after removing dirt and dust. (In order to prevent oxidization scale from forming inside the piping).
- The refrigerant pipes are of particular importance.
The installation work for refrigerant cycles in separate-type air conditioners must be carried out perfectly.

1. Refer to the table below for the pipe diameters equivalent lengths and indoor/outdoor unit difference of elevation.

Model Name	Pipe diameter (mm)		Equivalent length (m)	Difference of elevation (m)	
	Liquid-side pipes	Gas-side pipes			
CU-W18BBP5	CU-V18BBP5	ø6.35	ø12.70	40	30
CU-W24BBP5	CU-V24BBP5	ø6.35	ø15.88	50	30
	CU-V24BBP8				
CU-W28BBP5	CU-V28BBP5	ø9.52	ø15.88	50	30
CU-W28BBP8	CU-V28BBP8				
CU-W34BBP8	CU-V34BBP8	ø9.52	ø19.05	50	30
CU-W43BBP8	CU-V43BBP8				
CU-W50BBP8	CU-V50BBP8				

2. Local pipes can project in any of four directions.

- Make holes in the pipe panels for the pipes to pass through.
- Be sure to install the pipe panels to prevent rain from getting inside the outdoor unit.

[Removing the service panel].

- (1) Remove the two mounting screws.
- (2) Slide the service panel downward to release the pawls.
After this, pull the service panel toward you to remove it.

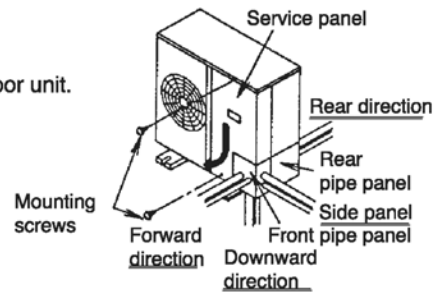

3. Notes when connecting the refrigerant pipes.

- Use clean copper, pipes with no water or dust on the insides.
- Use phosphorus-free, unjointed copper pipes for the refrigerant pipes.
- If it is necessary to cut the refrigerant pipes, be sure to use a pipe cutter, and use compressed nitrogen or an air blower to clean out any foreign particles from inside the pipe.
- Be careful not to let any dust, foreign materials or water get inside the pipes during connection.
- If bending the pipes, allow as large a bending radius as possible. Do not flex the pipes any more than necessary.
- If joining pipe ends, do so before tightening the flare nut.
- Always blow the pipe end with nitrogen while joining pipe ends.
(This will prevent any oxide scaling from occurring inside the pipe.)
- If using long pipe lengths with several joined pipe ends, insert strainers inside the pipes.(Strainers are not supplied.)
- When tightening the flare nuts, coat the flares (both inside surfaces) with a small amount of refrigerant oil, and screw in about 3-4 turns at first by hand.
- Refer to the following table for the tightening torques. Be sure to use two spanners to tighten.
(If the nuts are overtightened, it may cause the flares to break or leak.)

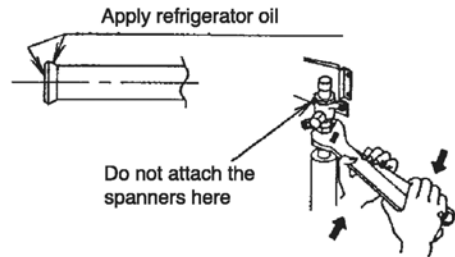

Flare nut fastening torque N·m (kgf·cm)			
ø6.35mm	18 (180)	ø15.88mm	65 (660)
ø9.52mm	42 (430)	ø19.05mm	100 (1020)
ø12.7mm	55 (560)		

4. After piping connection has been completed, make sure that the joint areas of the indoor and outdoor units are free from gas leakage by the use of nitrogen, etc.
5. Air purge within connection piping shall be carried out by evacuation.

6. HEAT INSULATION

⚠ Caution

Use a material with good heat-resistant properties as the heat insulation for the pipes. Be sure to insulate both the gas-side and liquid-side pipes. If the pipes are not adequately insulated, condensation or water leakages may occur.

Liquid-side pipes	Material that can withstand 120°C or higher
Gas-side pipes	

7. CHARGING WITH REFRIGERANT

- At the time of shipment from the factory, this unit is charged with enough refrigerant for an equivalent pipe length of 30m. If the equivalent pipe length used will be 30m or less, no additional charging will be necessary.
- If the equivalent pipe length will be between 30 and 50m (40m), charge with additional refrigerant according to the equivalent length given in the table below.
 - For standard type

Model Name		Additional charging amount	Equivalent length
CU-W18BBP5	CU-V18BBP5	0.02kg/m	40m
CU-W24BBP5	CU-V24BBP5	0.02kg/m	50m
	CU-V24BBP8		
CU-W28BBP5	CU-V28BBP5	0.05kg/m	50m
CU-W28BBP8	CU-V28BBP8		
CU-W34BBP8	CU-V34BBP8		
CU-W43BBP8	CU-V43BBP8		
CU-W50BBP8	CU-V50BBP8		

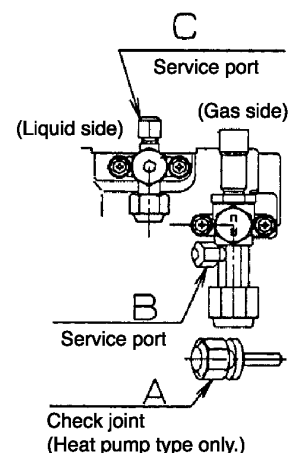

- Pump down operation
 - Operate the pump down according to the following procedures.

Procedure	Notes
1. Confirm the valve on the liquid side and the gas side is surely open.	
2. Press the COOL switch on outdoor printed board for 1 second or more.	Perform the cooling operation for five minutes or more.
3. Set the liquid side 3-way valve to the close position and until when the gauge indicates at 0.1Mpa (1kg/cm ² G).	When the valve is shut halfway, the compressor is occasionally damaged.
4. Immediately set the gas side valve to the close position and press the COOL switch (stop the operation unit).	

The pump down is completed above.

CHECKING THE PRESSURE

Check the pressure at the service port on the valve and the check joint where the pipe ends have been joined according to the table at below.

Heat pump model

	A	B
During cooling operation	High pressure	Low pressure
During heating operation	Low pressure	High pressure

Cooling model only

	C	B
During cooling operation	High pressure	Low pressure

8. ELECTRICAL WIRING

⚠ Warning	The units must be connected to the supply cables for fixed wiring by qualified technician. Feed the power source to the unit via a distribution switch board designed for this purpose, the switch should disconnected all poles with a contact separation of at least 3mm. When the supply cable is damaged, it must be replaced by qualified technician.
⚠ Caution	Be sure to install a current leakage breaker, main switch and fuse to the main power supply, otherwise electric shocks may result.
⚠ Caution	Be sure to connect the unit to secure earth connection. If the earthing work is not carried out properly, electric shocks may result. 
⚠ Warning	Wiring shall be connected securely by using specified cables and fix them securely so that external force of the cables may not transfer to the terminal connection section. Imperfect connection and fixing leads to fire, etc.

- Connect the power supply wiring and indoor/outdoor unit connection wiring according to the electrical circuit diagram instructions.
- Clamp the wires securely to the terminal connections using cord clamps so that no undue force is placed on the wires.
- Once all wiring work has been completed, tie the wires and cords together with the binding strap so that they do not touch other parts such as the compressor and pipes.

1. Connect the power supply line to a 3-phase/380-415V (or single-phase 220-240V) power supply.

If the phase is reversed, the self-diagnosis function will be activated and the unit will not operate. In such cases, switch over any two of the power supply wires (L1,L2,L3) (3-phase models only).

(Never operate the unit by pressing the electromagnetic switch.)

2. The equipment shall be connected to a suitable mains network with a main impedance less than the value indicated in the table of power supply specifications.
3. Be sure to connect the wires correctly to terminal board with connecting the crimp type ring terminal to the wires.
4. The binding screws inside the power supply box may become loosened due to vibration during transportation, so check that they are tightened securely.
5. Tighten the binding screws to the specified torque while referring to the table below.
6. If connecting two separate wires to a single crimped terminal, place the two crimped terminal wires together as shown in Fig. A. (If the arrangement shown in Fig. B is used, poor contacts or contact damage may result.)
7. If momentarily turning on the power supply for both the indoor and outdoor units, do not turn the power off again until at least 1 minute has passed (except when a reversed phase has been detected).

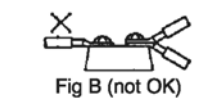
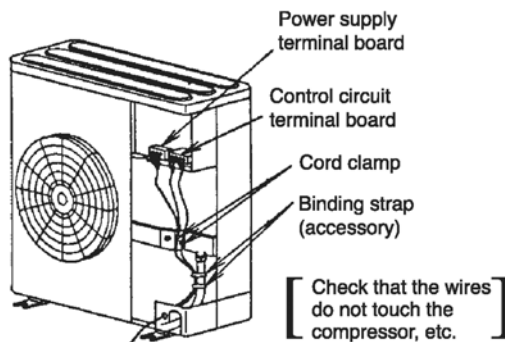

Warning Use only the specified cables for wiring connections. Connect the cable securely, and secure them properly so that no undue force will be applied to the terminal connections. If the terminals are loose or if the wires are not connected securely, fire may result.

Terminal screw	Tightening torque N·cm {kgf·cm}
M3	69~98 {7~10}
M4	157~196 {16~20}
M5	196~245 {20~25}

Refer to the following diagrams for details on how to connect the power supply cables and indoor/outdoor unit connection cables.

OUTDOOR UNIT/3-PHASE MODEL

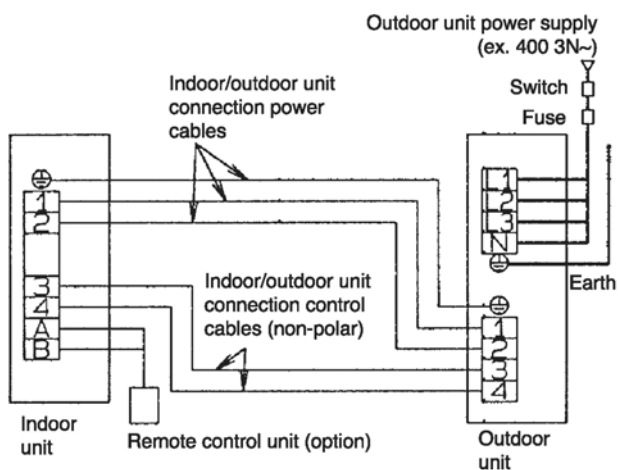

OUTDOOR UNIT/SINGLE-PHASE MODEL

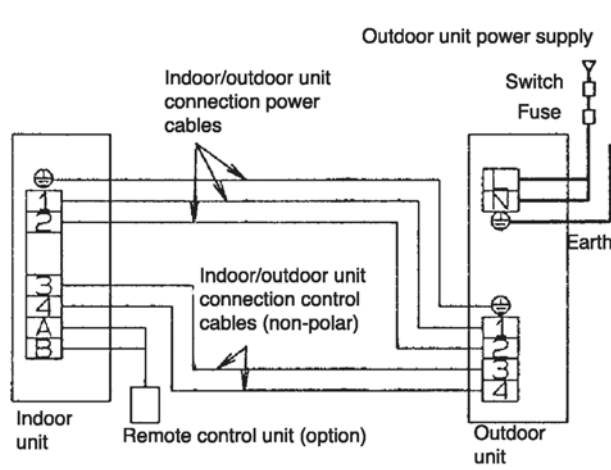

● Power supply specifications

Model name	Leakage current breaker (A)	Circuit breaker (Minimum Capacity)		Minimum power supply cables	4mm ² cable based on length (m)	Indoor/outdoor unit connection power cables (terminals ① ② ⊕)	Indoor/outdoor unit connection power cables (terminals ③ ④)	Maximum permissible impedance (Ω)
		Switch (A)	Fuse (A)					
CU-W18BBP5 CU-V18BBP5	220V-240V~	20	20	4mm ²	17	2.5mm ² x 3	1.0mm ² x 2	0.04
CU-W24BBP5 CU-V24BBP5	220V-240V~	30	30		13			0.04
CU-V24BBP8	380V-415V 3N~	10	10		41			0.025
CU-W28BBP5 CU-V28BBP5	220V-240V~	30	30		11			0.04
CU-W28BBP8 CU-V28BBP8	380V-415V 3N~	10	10		38			0.025
CU-W34BBP8 CU-V34BBP8	380V-415V 3N~	15	15		25			0.025
CU-W43BBP8 CU-V43BBP8	380V-415V 3N~	20	20		20			0.025
CU-W50BBP8 CU-V50BBP8	380V-415V 3N~	20	20		18			0.025

NOTE

- ⊕ 1. Where ground work (earth) is carried out, do not connect the ground return to the gas pipe, water line pipe, grounded circuit of the telephone and lightning rod, or ground circuit of other product in which earth leakage breaker is incorporated. (Such action is prohibited by statute, etc.)
- ! 2. In order to prevent malfunction (noise generation) of the equipment, carry out the wiring of the control cable for indoor and outdoor units (signal cable) isolating it from other power cable with separate cable.
3. Use the standard power supply cables for Europe (such as H05RN-F or H07RN-F which conforms to CENELEC (HAR) rating specifications) or use the cables based on IEC standard. (245IEC57, 245IEC66)
4. Select the particular size of electrical wire for power supply cables in accordance with the standards of the given nation and region.

9. CONNECTING POWER SUPPLY CABLES

- If reversed phase is detected and the self-diagnosis function is activated after connecting the power supply cables, carry out the following operation.

Switch over any two of the power supply wires which are connected to the power supply terminal board.

Turn off the main power supply before correcting the phase.

CAUTION

- Never operate the unit by pressing the electromagnetic switch.
- Never correct the phase by switching over any of the wires inside the unit.

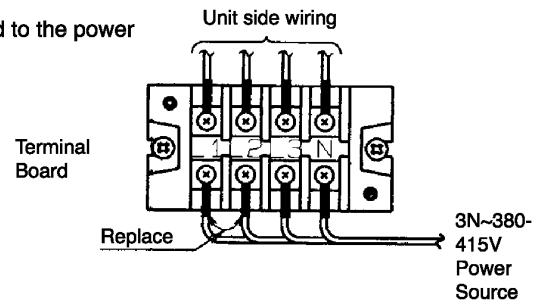

10. PRECAUTIONS WITH REGARD TO TEST OPERATION

CAUTION

- Always be sure to use a properly-insulated tool to operate the switch on the circuit board. (Do not use your finger or a metallic object.)
- Never turn on the power supply until all installation work has been completed.
- Turn on the circuit-breaker 12 hours or more before a test run. (By supplying power to crankcase heater, compressor is warmed and liquid compressing is prevented.)
- For three-phase models, check that the phase is not reversed.
(If the phase is reversed, the LED on the printed circuit board will flash.)
- Check that the voltage is 90% of rated voltage or higher when starting the unit.
(The unit will not operate if the voltage is less than 90% of rated voltage.)
- Test operation can be carried out using the remote control unit or by using the switch on the printed circuit board inside the outdoor unit.
- If carrying out test operation at the printed circuit board of the outdoor unit, follow the procedure given below. (If using the remote control unit to carry out test operation, refer to the installation manual which is supplied with the indoor unit.)
- Press the COOL or HEAT switch for 1 second or more. The LEDs will operate as follows during test operation.
(Be sure to select cooling mode first, and run the units in this mode for 5 minutes or more.)

* The compressor will stop momentarily when the operation mode is changed.

Test operation mode	LEDs on printed circuit board
Cooling test mode	LEDs 2-4 flash, LEDs 5-8 switch off
Heating test mode	LEDs 2-5 switch off, LEDs 6-8 flash

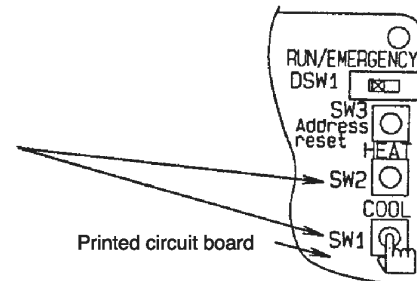

- Press the TEST button once more to cancel test operation mode.
- When performing heating test operation when the outside temperature is high, or cooling test operation when the outside temperature is low, the protection circuits may sometimes operate within a few minutes.

NOTE 1

These units are equipped with connection error prevention circuits. If the units do not operate, it is possible that the connection error prevention circuits have been operated. In such cases, check that the drive wires (connected to terminals ① and ②) and the control wires (connected to terminals ③ and ④) are connected correctly. If they are connected incorrectly, connect them correctly. Normal operation should then commence.

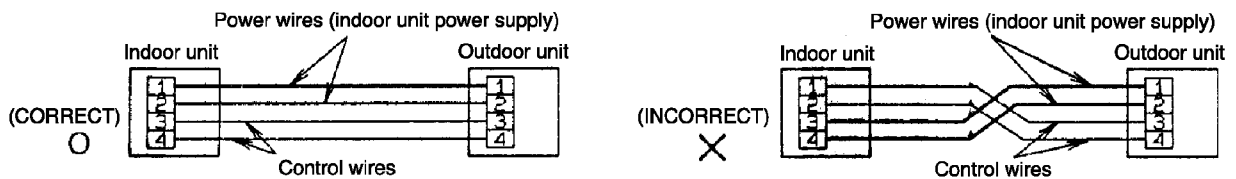
**NOTE 2**

Do not short the remote control unit wires to each other. (The protection circuit will be activated and the units will not operate.) Once the cause of the short is eliminated, normal operation will then be possible.

NOTE 3

When running the units in heating mode during test operation, be sure to run the units in cooling mode first before selecting this mode. If heating mode is selected first, it may cause problems with operation of the compressor.

NOTE 4

Test operation should be carried out for a minimum of 5 minutes. (Test operation will be cancelled automatically after 30 minutes.)

NOTE 5

Test operation mode should always be cancelled once test operation itself has been completed.

NOTE 6

Emergency operation can be carried out by setting the DSW1 switch on the printed circuit board inside the outdoor unit to the EMERGENCY position. During emergency operation, any abnormalities detected by the temperature thermistors are ignored while the outdoor unit is operating, so that long-term operation in this mode should be avoided. After emergency mode operation has been completed and normal operation is to be resumed, turn the power supplies for the indoor and outdoor units off and then back on again.

Set the abnormal temperature thermistor only to the setting in the table below when carrying out emergency operation.

	Thermistor	Cooling operation	Heating operation
Indoor unit side	Room temperature detection	Fixed at 25°C	
	Pipe temperature detection	Shorted	Open
Outdoor unit side	Discharge thermistor detection	Open	Open
	Heat exchanger outlet temperature detection	Shorted	Open

* Refer to the electrical circuit diagrams for details on wiring for each thermistor.

NOTE 7

If the self-diagnosis function reports a problem but more than one problem has developed at the indoor and/or outdoor units, the problem display on the remote control unit may not match the LED display on the outdoor unit printed circuit board. In such cases, check both locations and remove the causes of the problems.

11. AS TO MAKING THE INSPECTION AFTER COMPLETION OF WORK FULLY UNDERSTOOD

- At the time when the work has been completed, measure and record the characteristics of test run without fail and keep the measuring date, etc.
- Carry out the measurement regarding room temperature outside air temperature, suction and air discharge temperatures, wind velocity, wind volume, voltage current, presence of abnormal vibration, operating pressure, piping temperature, compressive pressure, airtight pressure as items to be measured.
- As to the structure and appearance, check following items.

<ul style="list-style-type: none"> <input type="checkbox"/> Short circuit of the blow-out air. <input type="checkbox"/> Smooth flow of the drain <input type="checkbox"/> Reliable thermal insulation <input type="checkbox"/> Leakage of refrigerant 	<ul style="list-style-type: none"> <input type="checkbox"/> Mistake in wiring <input type="checkbox"/> Reliable connection of the grand wire <input type="checkbox"/> Looseness in terminal screw, fastening torque M3... 69-98N·cm{7-10kgf·cm} M4... 157-196N·cm{16-20kgf·cm} M5... 196-245N·cm{20-25kgf·cm}
---	--

12. AS TO DELIVERY TO THE CUSTOMER

- Request the customer to operate this air conditioner viewing instruction manual come with indoor unit in practice and explain how to operate.
- Deliver the instruction manual to the customer without fail.

13. AS TO PARTS TO BE SOLD SEPARATELY

We are preparing air guider for outdoor unit and parts to be sold separately for indoor unit, etc., however, as to details of mounting method, etc., observe respective instruction manual.

31 REPLACEMENT PARTS

31.1. INDOOR UNIT

CS-W50BTP

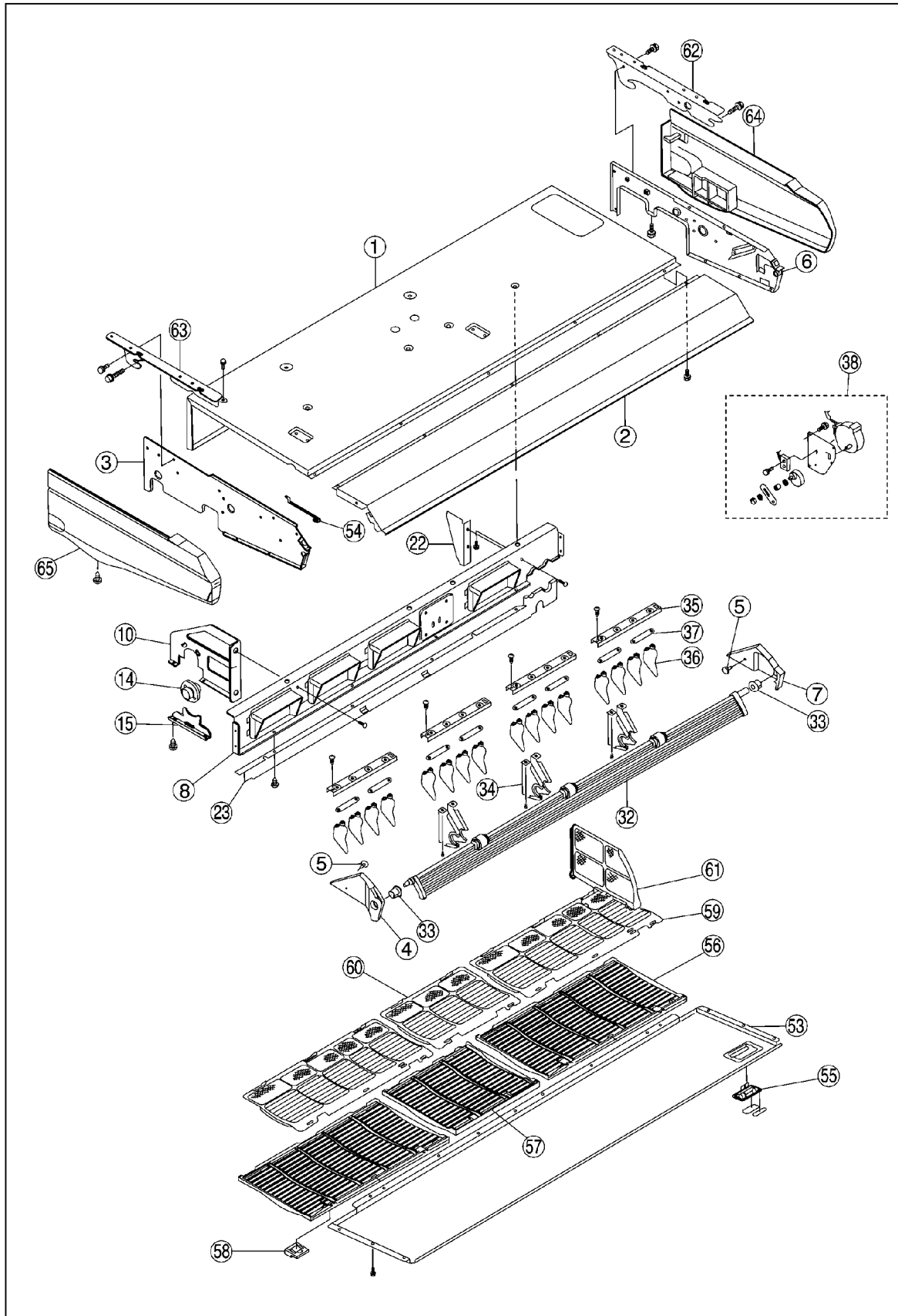

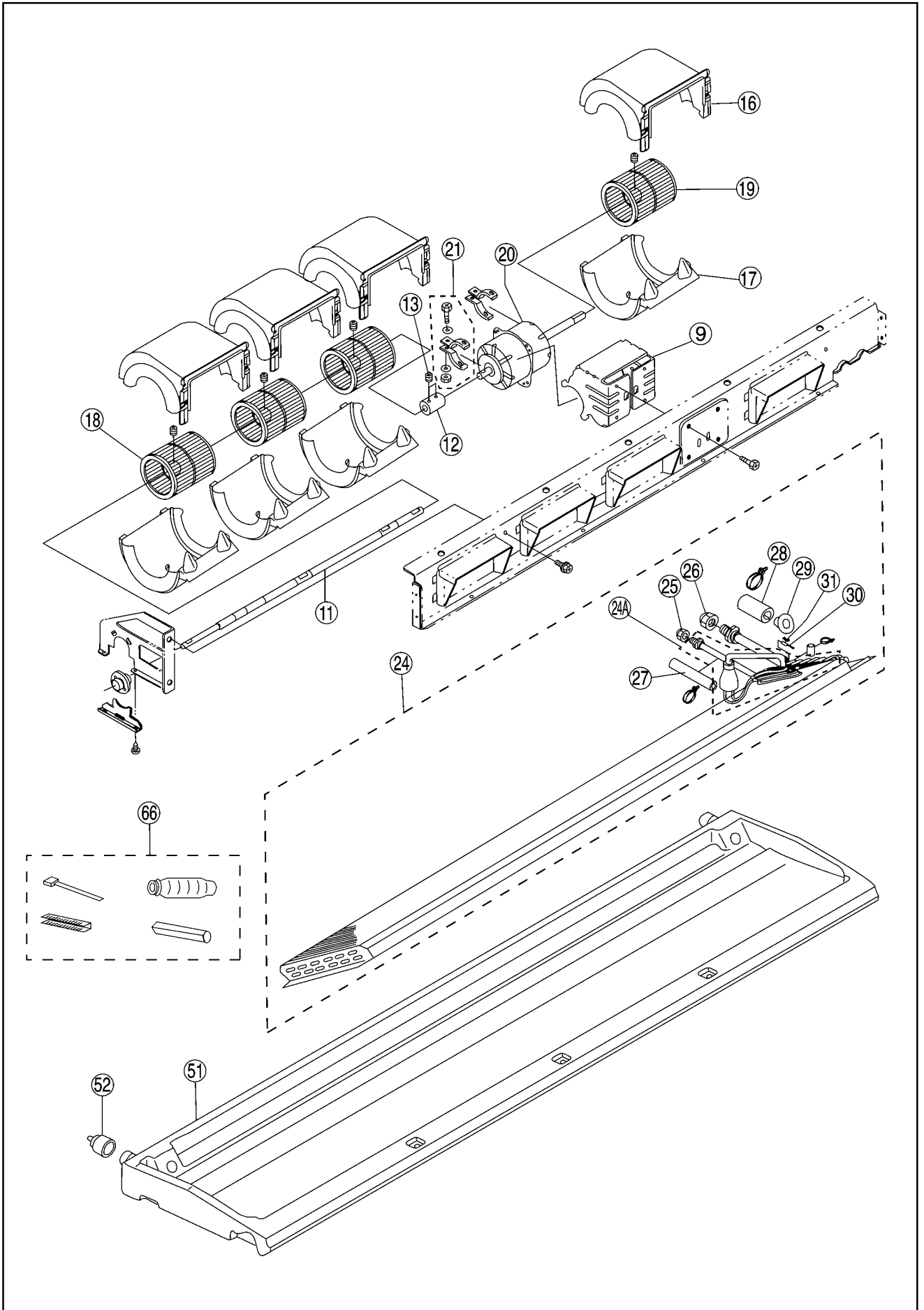

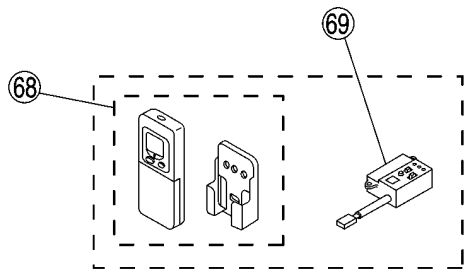
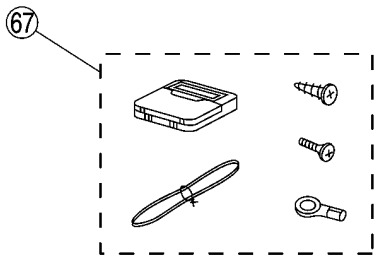
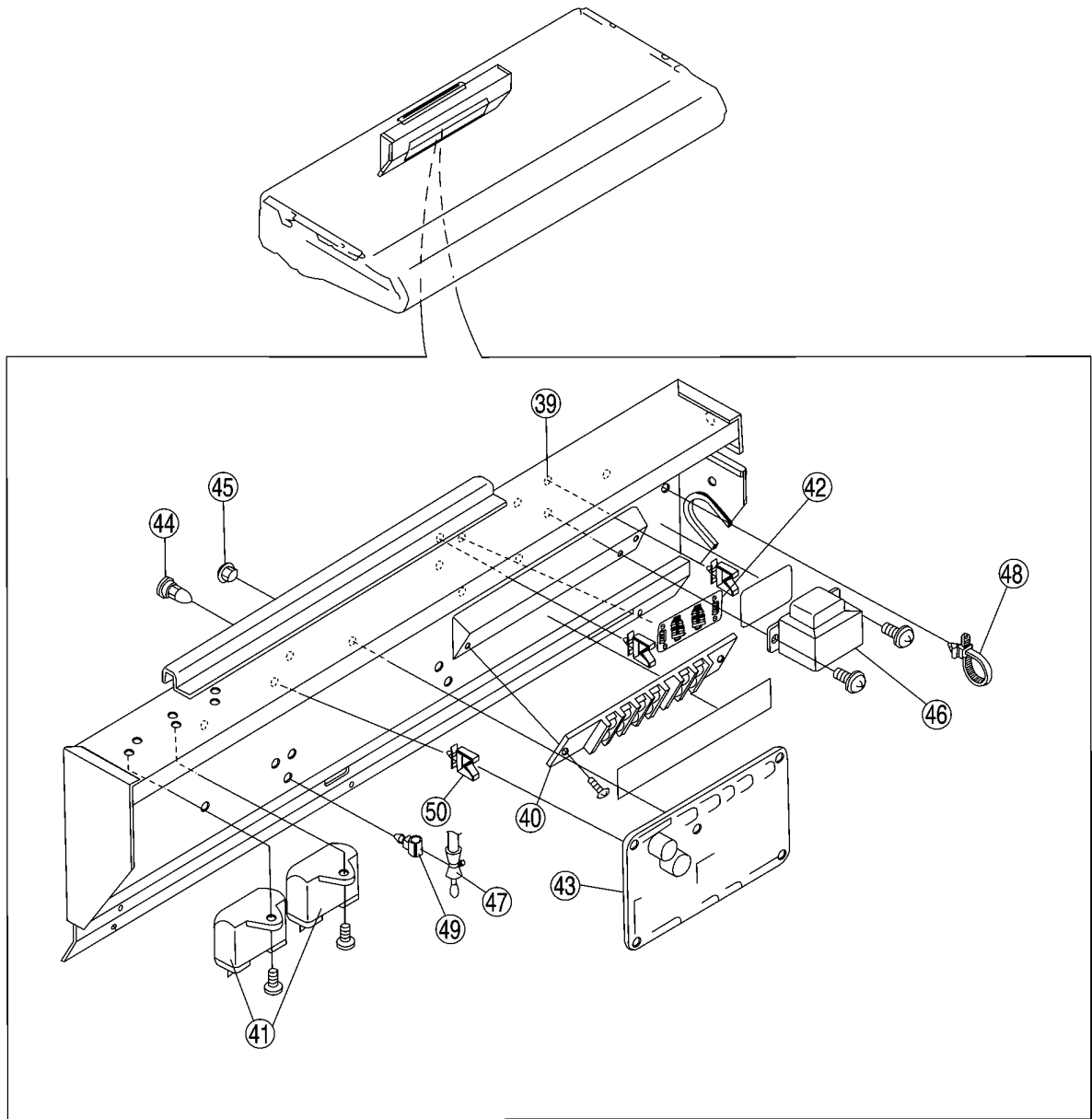

NO.	PART DESCRIPTION	QTY	CS-W50BTP
1	CABINET TOP PLATE	1	CWE001016
2	CABINET FRONT PLATE	1	CWG07K1008
3	CABINET SIDE PLATE (L)	1	CWD63K1003
4	VANE SUPPORTER (L)	1	CWG071144
5	CATCHER	2	CWH601005
6	CABINET SIDE PLATE (R)	1	CWD63K1003
7	VANE SUPPORTER (R)	1	CWG071144
8	BLOWER WHEEL BASE ASS'Y	1	CWD90K1008
9	BRACKET FAN MOTOR ASS'Y	1	CWD54K1005
10	BEARING HOLDER	1	-
11	FAN SHAFT	1	CWH631031
12	COUPLING SHAFT COMPLETE	1	CWH08C1001
13	SCREW-COUPLING SHAFT COMPLETE	2	CWH55424
14	BEARING	1	CWH64C1001
15	BEARING COVER	1	-
16	AIR GUIDER BLOWER WHEEL (TOP)	4	CWD321032
17	AIR GUIDER B. WHEEL (BOTTOM)	4	CWD321033
18	BLOWER WHEEL	3	CWH011010
19	BLOWER WHEEL	1	CWH011005
20	FAN MOTOR	1	CWA921056
21	FAN MOTOR SUPPORTER	2	CWD93C1027
22	SIDE FILTER SEAL	1	CWD911158
23	SEPARATOR	1	CWD911109
24	EVAPORATOR COMPLETE	1	CWB30C1286
24a	TUBE ASS'Y (CAPIL. TUBE-EVA)	1	CWT022580
25	FLARE NUT (3/8")/(1/4")	1	CWT25005 (3/8")
26	FLARE NUT (6/8")/(5/8")	1	CWT251012 (6/8")
27	HEATPROOF TUBE [LIQUID] (10/6)	1	CWG021037 (10)
28	HEATPROOF TUBE [GAS] (22/16)	1	CWG021027 (22)
29	WATERPROOF COVER	1	CWG251007
30	SENSOR-EVAPORATOR	1	CWA501038
31	SPRING FOR SENSOR	1	CWH711010
32	VANE COMPLETE	1	CWE24C1024
33	VANE SIDE HOLDER	2	CWH511027
34	FULCRUM	3	CWH621008A
35	VERTICAL VANE HOLDER (MANUAL)	4	CWD911107
36	VERTICAL VANE (HORIZ.AIR FLOW)	16	CWE241051
37	CONNECTING BAR	8	CWE261019
38	AIR SWING MOTOR COMPLETE	1	CWA98C1004
39	CONTROL BOARD ASS'Y	1	CWH10K1018
40	TERMINAL BOARD	1	CWA281015
41	CAPACITOR-FAN MOTOR (MF/V)	1	DS461305QP-A (0.3/460)
42	NOISE FILTER	1	CWA491018
43	ELECTRONIC CONTROLLER	1	CWA73C1167
44	LOCKING GUARD SPACER	8	CWH541026
45	PCB SUPPORTER	1	CWH541027
46	TRANSFORMER	1	CWA401033
47	LEAD WIRE-SENSOR	1	CWA67C3801
48	CABLE CLIP(CORD CLAMPER)	1	CWH88133
49	HOLDER-SENSOR	1	CWH321015
50	WIRE SADDLE	3	CWH881019
51	DRAIN PAN ASS'Y	1	CWH40K1013
52	DRAIN PLUG	1	CWB821002
53	CABINET BOTTOM PLATE	1	CWE051002
54	CURVED WIRE	1	CWH751002
55	RAY RECEIVER HOLDER	1	CWD93C1026
56	INTAKE GRILLE (LARGE)	2	CWE221029
57	INTAKE GRILLE (SMALL)	1	CWE221030
58	GRILLE SLIDE HOOK	6	CWH891001
59	AIR FILTER (MAIN)	2	CWD001040
60	AIR FILTER (MIDDLE)	1	CWD001042
61	AIR FILTER (SIDE)	1	CWD001041
62	BRACKET HANGER (R)	1	CWD601014
63	BRACKET HANGER (L)	1	CWD601015
64	CABINET SIDE COVER (R)	1	CWE041024
65	CABINET SIDE COVER (L)	1	CWE041025
66	FLEXIBLE PIPE-ACCESSORY	1	CWH82C1109
67	WIRED REMOTE CONTROL COMPLETE	1	CWA75C2239
68	WIRELESS R/CONTROL COMP. (HP)	1	CWA75C2247
68	WIRELESS R/CONTROL COMP. (C)	1	CWA75C2250
69	RAY RECEIVER (HEAT PUMP MODEL)	1	CWD76C1003
69	RAY RECEIVER (COOLING ONLY)	1	CWD76C1002
	OPERATING INSTRUCTION	1	CWF563598
	INSTALLATION INSTRUCTION	1	CWF612269

All parts are supplied from MAICO, Malaysia (Vendor Code: 061)

31.2. OUTDOOR UNIT

CU-V50BBP8, CU-W50BBP8

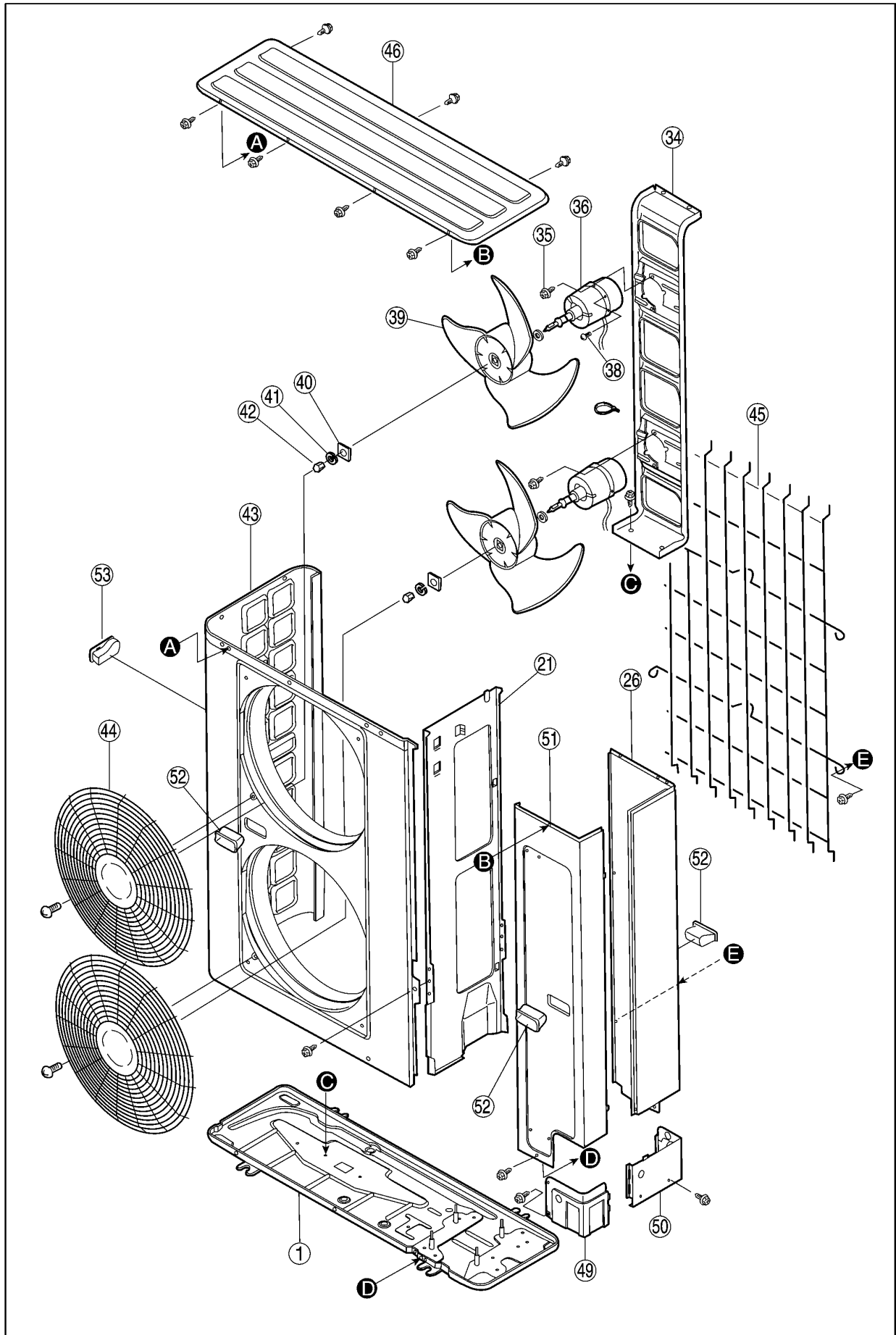

CU-W50BBP8 (Heat pump type)

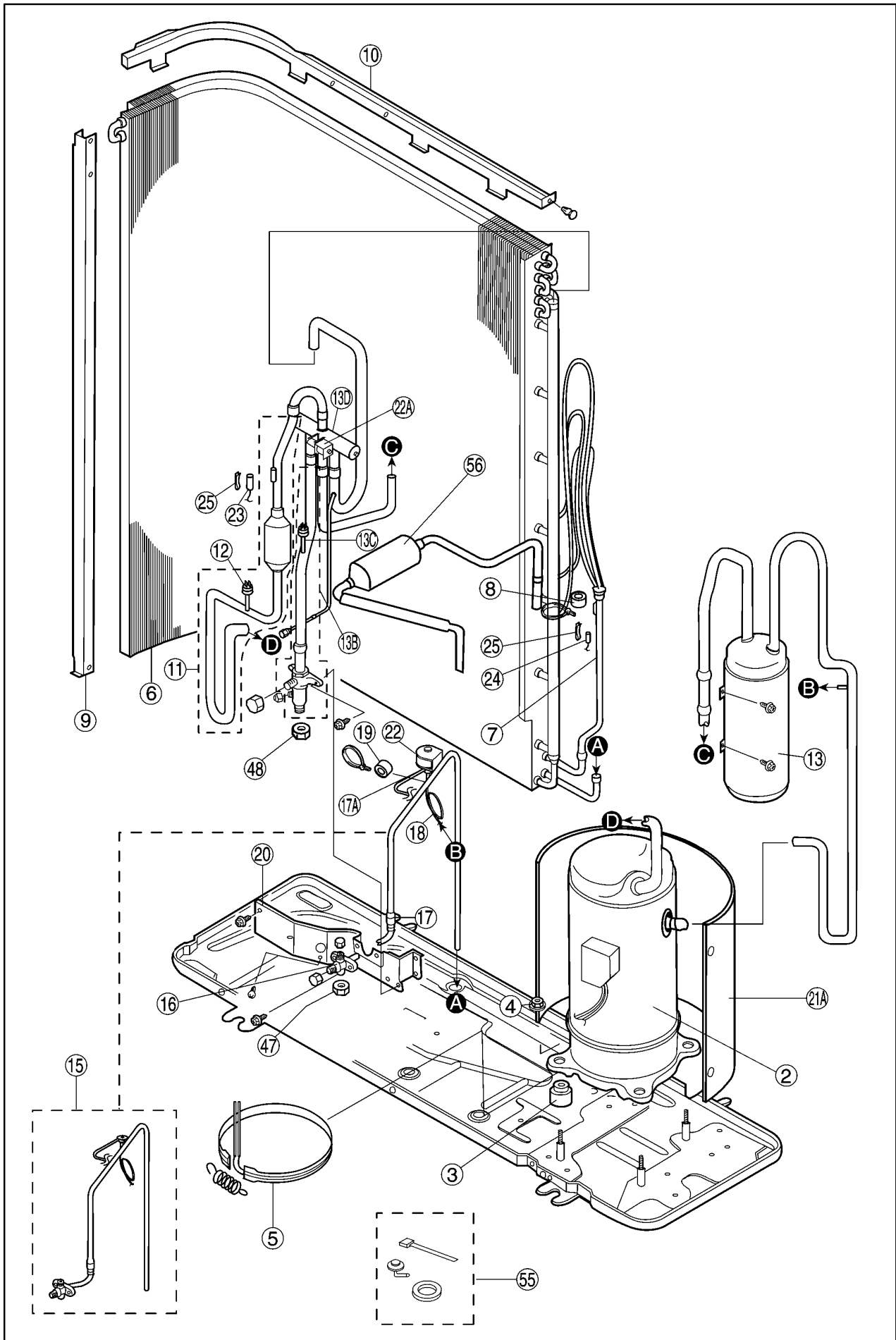

CU-V50BBP8 (Cooling only type)

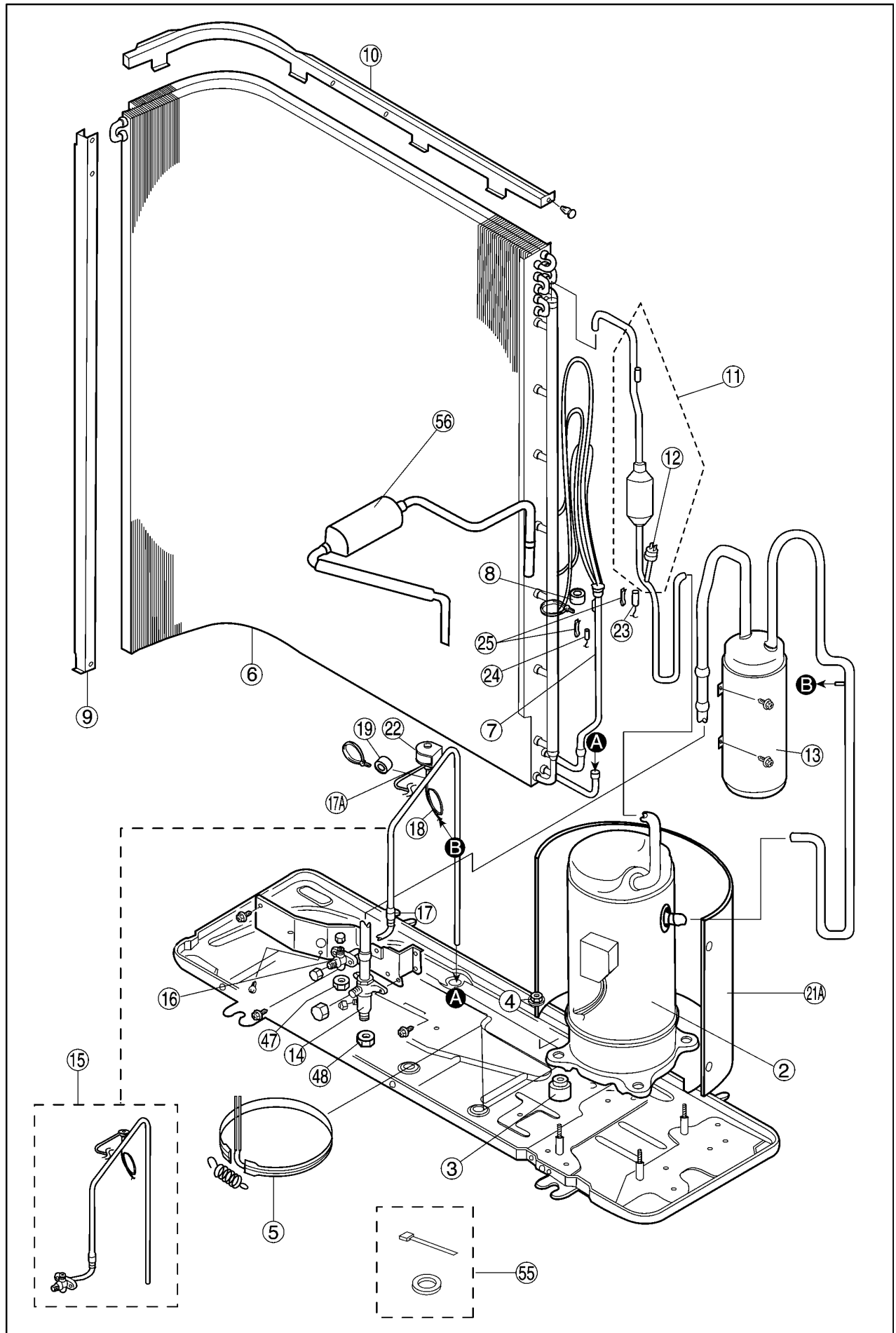

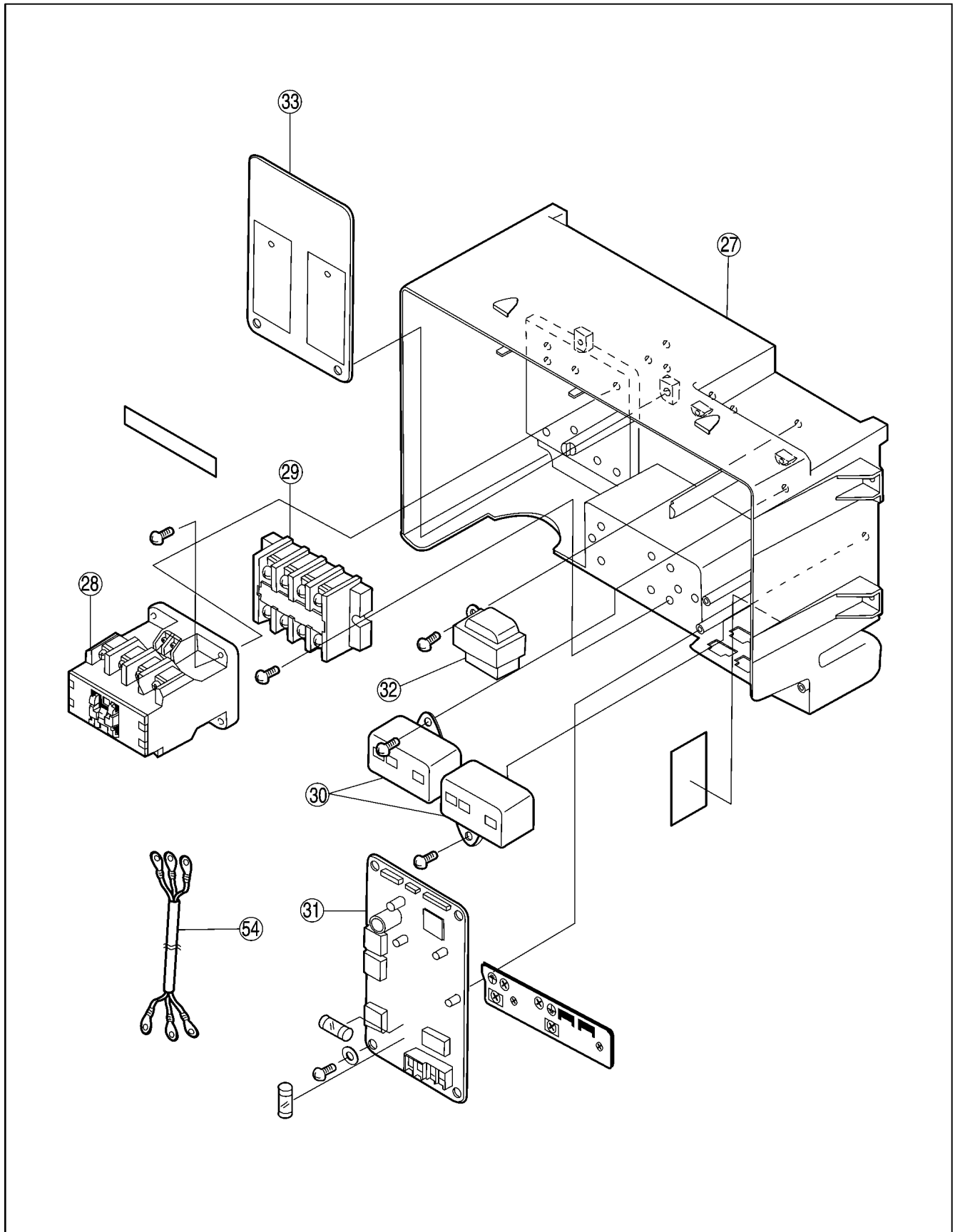

CU-W50BBP8

NO.	PART DESCRIPTION	QTY.	CU-W50BBP8
1	BASE FAN ASS'Y	1	CWD52K1040A
2	COMPRESSOR	1	ZR68KCE-TFD
3	ANTI-VIBRATION BUSHING	4	CWH501020
4	NUT FOR COMP. MOUNT.	3	CWH4582065
5	CRANKCASE HEATER	1	CWA341002
6	CONDENSER COMPLETE	1	CWB32C1286
7	TUBE ASS'Y (CAPILLARY TUBE)	1	CWT07K1109
8	PIPE HOLDER RUBBER	1	CWG251021
9	CONDENSER SIDE PLATE	1	CWD911123
10	CONDENSER TOP PLATE	1	CWD911133
11	TUBE ASS'Y(PRESSURE SWITCH)	1	CWT022869
12	HIGH PRESSURE SWITCH	1	CWA101003
13	ACCUMULATOR	1	CWB13C1030
13b	TUBE ASS'Y(PRESS.SW + VALVE)	1	CWT022620
13c	HEATING PRESSURE SWITCH	1	CWA101004
13d	4-WAYS VALVE	1	CWB001015
15	TUBE ASS'Y(VALVE+STRAINER)	1	CWT022629
16	3-WAYS VALVE	1	CWB011091
17	STRAINER	1	CWB111005
17a	2-WAYS VALVE	1	CWB02299
18	CAPILLARY TUBE for VALVE	1	CWB15K1039
19	PIPE HOLDER RUBBER	1	CWG251015
20	HOLDER-SERVICE VALVE	1	CWD911131
21	SOUND-PROOF BOARD ASS'Y	1	CWH15K1010
21a	SOUND PROOF MATERIAL-COMP.	1	CWG302103
22	V-COIL COMPLETE	1	CWA43C2067
22a	V-COIL COMPLETE-4 WAY VALVE	1	CWA43C2063
23	PIPING SENSOR (DISCHARGE)	1	CWA501044
24	PIPING SENSOR (COIL)	1	CWA501045
25	SPRING FOR SENSOR	2	CWH711010
26	CABINET REAR PLATE	1	CWE02C1010
27	CONTROL BOARD	1	CWH141004
28	COMPRESSOR RELAY	1	CWA001005
29	TERMINAL BOARD ASS'Y	1	CWA28K1029
30	CAPACITOR-FAN MOTOR	2	DS461355QP-A (3.5/460)
31	ELECTRONIC CONTROLLER	1	CWA73C1211
32	TRANSFORMER	1	CWA401029
33	CURRENT TRANSFORMER BOARD	1	CWA742592
34	BRACKET-FAN MOTOR	1	CWD541028
35	SCREW-BRACKET FAN MOTOR	4	CWH551040
36	FAN MOTOR	2	CWA951078
38	SCREW-FAN MOTOR	8	CWH55442
39	PROPELLER FAN	2	CWH001007
40	WASHER for P.FAN	2	CWH571013
41	SPRING WASHER for P.FAN	2	XWB10B
42	NUT for PROPELLER FAN	2	CWH56033
43	P.FAN AIR GUIDER PLATE	1	CWE061044A
44	FAN GUARD	2	CWD041014A
45	CONDENSER GUARD	1	CWD041017A
46	CABINET TOP PLATE COMPLETE	1	CWE03C1005
47	FLARE NUT (3/8")	1	CWT25005
48	FLARE NUT (6/8")	1	CWT251012
49	PIPE COVER (FRONT)	1	CWD601017A
50	PIPE COVER (BACK)	1	CWD601018A
51	CABINET FRONT PLATE	1	CWE061046A
52	HANDLE	3	CWE161008
53	HANDLE	1	CWE161009
54	LEADWIRE-COMPRESSOR	1	CWA67C3656
55	ACCESSORY COMPLETE	1	CWH82C1105
	INSTALLATION INSTRUCTION	1	CWF612270
56	DRYER	1	CWB101014

The above parts are kept for seven years in accordance with MEI service policy.

CU-V50BBP8

NO.	PART DESCRIPTION	QTY.	CU-V50BBP8
1	BASE PAN ASS'Y	1	CWD52K1040A
2	COMPRESSOR	1	ZR68KCE-TFD
3	ANTI-VIBRATION BUSHING	4	CWH501020
4	NUT FOR COMP. MOUNT.	3	CWH4582065
5	CRANKCASE HEATER	1	CWA341002
6	CONDENSER COMPLETE	1	CWB32C1192
7	TUBE ASS'Y(CAPILLARY TUBE)	1	CWT07K1080
8	PIPE HOLDER RUBBER	1	CWG251021
8	PIPE HOLDER RUBBER	1	CWG251015
9	CONDENSER SIDE PLATE	1	CWD911123
10	CONDENSER TOP PLATE	1	CWD911133
11	TUBE ASS'Y(PRESSURE SW+RCVR)	1	CWT022868
12	HIGH PRESSURE SWITCH	1	CWA101003
13	ACCUMULATOR	1	CWB131019A
14	TUBE ASS'Y(3 WAY VALVE-GAS)	1	CWT022606
15	TUBE ASS'Y(VALVE+STRAINER)	1	CWT022609
16	3-WAYS VALVE	1	CWB011091
17	STRAINER	1	CWB111017
17a	2-WAYS VALVE	1	CWB02299
18	CAPILLARY TUBE for VALVE	1	CWB15K1039
19	PIPE HOLDER RUBBER	1	CWG251015
21	SOUND-PROOF BOARD ASS'Y	1	CWH15K1010
21a	SOUND PROOF MATERIAL-COMP.	1	CWG302103
22	V-COIL COMPLETE	1	CWA43C2067
23	PIPING SENSOR (DISCHARGE)	1	CWA501044
24	PIPING SENSOR (COIL)	1	CWA501045
25	SPRING FOR SENSOR	2	CWH711010
26	CABINET REAR PLATE	1	CWE02C1009
27	CONTROL BOARD	1	CWH141004
28	COMPRESSOR RELAY	1	CWA001005
29	TERMINAL BOARD ASS'Y	1	CWA28K1029
30	CAPACITOR-FAN MOTOR	2	DS461355QP-A (3.5µF/460)
31	ELECTRONIC CONTROLLER (EEPROM)	1	CWA73C1202
32	TRANSFORMER	1	CWA401029
33	CURRENT TRANSFORMER BOARD	1	CWA742592
34	BRACKET FAN MOTOR	1	CWD541028
35	SCREW-BRACKET FAN MOTOR	4	CWH551040
36	FAN MOTOR	2	CWA951078
38	SCREW-FAN MOTOR	8	CWH55442
39	PROPELLER FAN	2	CWH001007
40	WASHER for P.FAN	2	CWH571013
41	SPRING WASHER for P.FAN	2	XWB10B
42	NUT for PROPELLER FAN	2	CWH56033
43	P.FAN AIR GUIDER PLATE	1	CWE061044A
44	FAN GUARD	2	CWD041014A
45	CONDENSER GUARD	1	CWD041017A
46	CABINET TOP PLATE COMPLETE	1	CWE03C1005
47	FLARE NUT (3/8")	1	CWT25005
48	FLARE NUT (6/8")	1	CWT251012
49	PIPE COVER (FRONT)	1	CWD601017A
50	PIPE COVER (BACK)	1	CWD601018A
51	CABINET FRONT PLATE	1	CWE061046A
52	HANDLE	3	CWE161008
53	HANDLE	1	CWE161009
54	LEADWIRE-COMPRESSOR	1	CWA67C3656
55	ACCESSORY COMPLETE	1	CWH82C1105
56	DRYER	1	CWB101014
	INSTALLATION INSTRUCTION	1	CWF612270

All parts are supplied from MAICO Malaysia (Vendor Code : 061)