

Service Manual

Room Air Conditioner



CS-VC75KE CU-VC75KE
CS-VC95KE CU-VC95KE
CS-VC125KE CU-VC125KE

⚠ WARNING

This service information is designed for experienced repair technicians only and is not designed for use by the general public. It does not contain warnings or cautions to advise non-technical individuals of potential dangers in attempting to service a product. Products powered by electricity should be serviced or repaired only by experienced professional technicians. Any attempt to service or repair the product or products dealt with in this service information by anyone else could result in serious injury or death.

⚠ PRECAUTION OF LOW TEMPERATURE

In order to avoid frostbite, be assured of no refrigerant leakage during the installation or repairing of refrigeration circuit.

CONTENTS

	Page		Page
1 Features	2	13 Servicing Information	78
2 Functions	3	14 Troubleshooting Guide	82
3 Product Specifications	6	15 Technical Data	84
4 Dimensions	12	16 Exploded View	87
5 Refrigeration Cycle Diagram	14	17 Replacement Parts List	88
6 Block Diagram	15	18 Exploded View	89
7 Wiring Diagram	17	19 Replacement Parts List	90
8 Operation Details	19	20 Exploded View	91
9 Operating Instructions	27	21 Replacement Parts List	92
10 Installation And Servicing Air Conditioner Using R410A	51	22 Electronic Parts List	93
11 Installation Instructions	62	23 Electronic Circuit Diagram	94
12 2-way, 3-way Valve	71		

Panasonic

© 2000 Matsushita Air-Conditioning Corp. Sdn. Bhd. (183914D) All rights reserved. Unauthorized copying and distribution is a violation of law.

1 Features

- **Environmental Friendly**
 - R410A, which does not contain chlorine, is used as its refrigerant, so there is no danger of damage to the ozone layer in Stratosphere.
- **High Efficiency**
- **Compact Design**
- **Comfort Environment**
 - 8 hours of sleep mode operation
 - Air filter with function to reduce dust and smoke
 - Wider range of horizontal discharge air
- **Auto Restart**
 - Random auto restart after power failure for safety restart operation
- **Removable and Washable Front Panel**
- **Remote Control Self-illuminating Button**
- **Catechin Air Purifying Filter**
 - Trap dust, tobacco smoke and tiny particles
 - Prevent the growth of bacteria and viruses trapped
- **Deodorizing Air Purifying Filter**
 - Remove unpleasant odors from the air
- **Quality Improvement**
 - Gas leakage protection
 - Prevent compressor reverse cycle
 - 2-stage OLP to protect compressor
 - Noise prevention during soft dry operation.
- **Service Improvement**
 - Easy fan motor replacement procedure
- **Operation Improvement**
 - Economy mode to reduce electrical power consumption
 - Powerful mode to reach the desired room temperature quickly
- **Long Installation Piping**
 - CS/CU-VC75KE, CS/CU-VC95KE, long piping up to 10 meter
 - CS/CU-VC125KE, long piping up to 15 meter

2 Functions

Remote Control

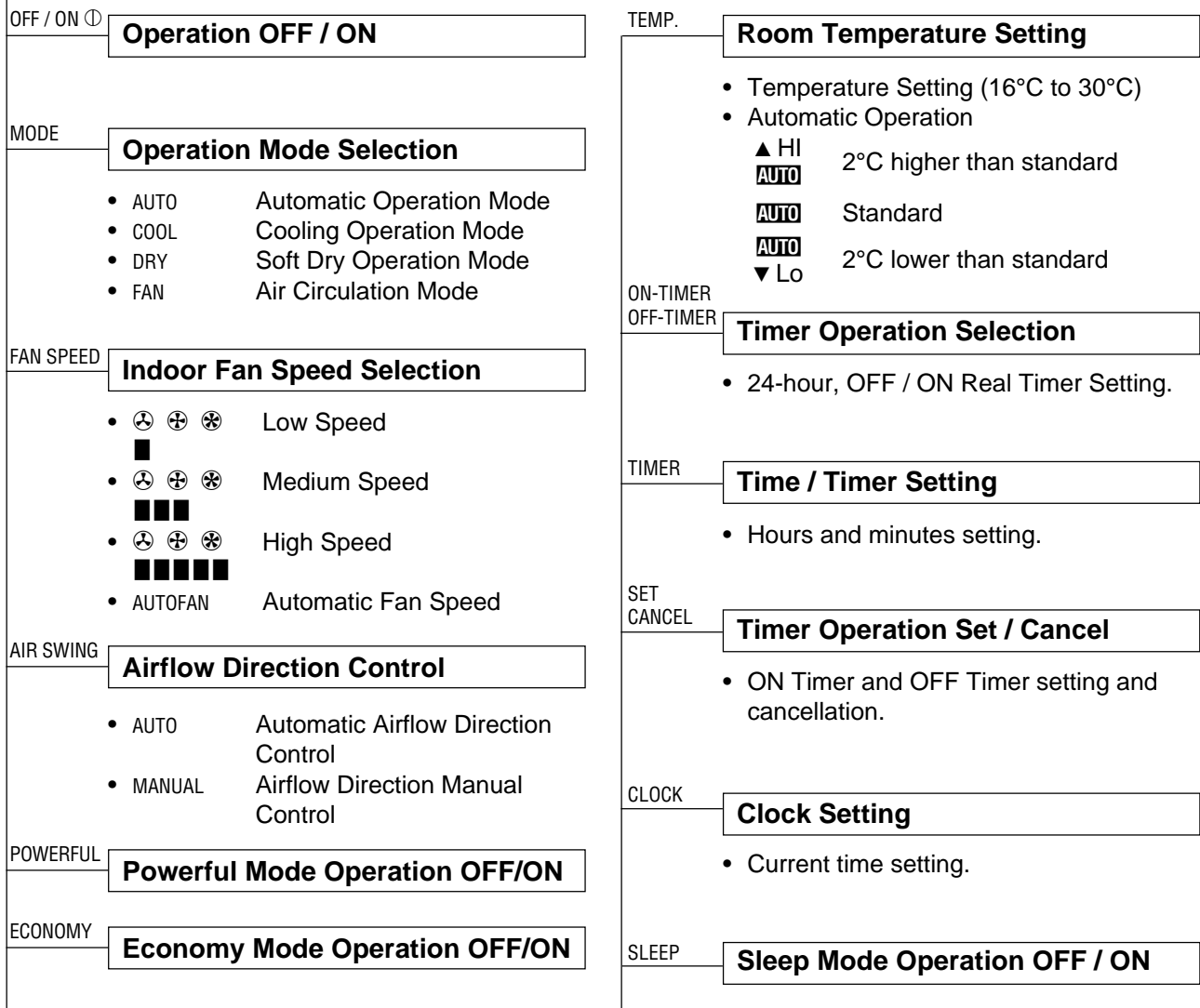
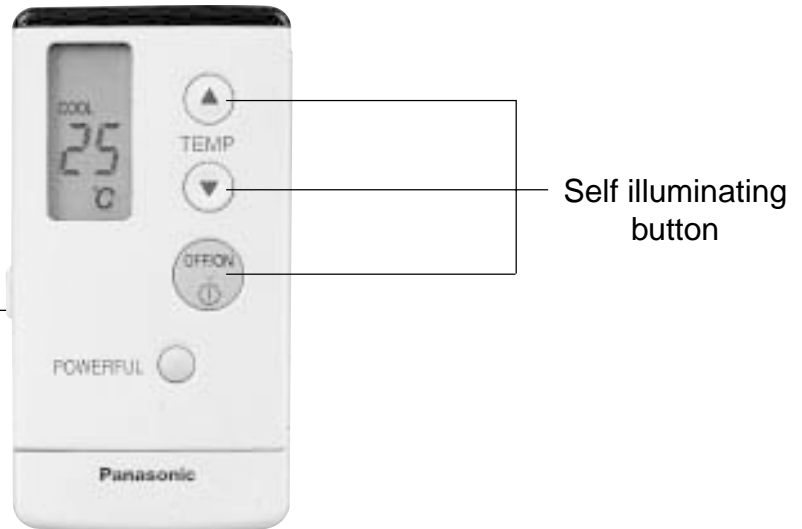

Indoor Unit



AUTO
OFF / ON

Automatic Operation Button

- Press for < 5s to operate Automatic operation mode.
(Used when the remote control cannot be used.)
- Press continuously for 5s or < 10s to operate Test Run/Pump down. "Beep" sound will be heard at the 5th second.
(Used when test running or servicing.)
- Press continuously for 10s and above to omit or resume the remote control signal receiving sound. "Beep, beep" sound will be heard at the 10th second.

Operation Indication Lamps (LED)

- POWER (Green) Lights up in operation, blinks in Automatic Operation Mode judging.
- SLEEP (Orange) Lights up in Sleep Mode Operation.
- TIMER (Orange) Lights up in Timer Setting.
- POWERFUL (Orange) .. Lights up in Powerful Mode Operation.
- ECONOMY (Green) Lights up in Economy Mode Operation.

Operation Mode

- Cooling, Soft Dry, Air Circulation and Automatic Mode.

Powerful Operation

- Reaches the desired room temperature quickly.

Economy Operation

- To reduce electrical power consumption.

Random Auto Restart Control

- Operation is restarted randomly after power failure at previous setting mode.

Anti-Freezing Control

- Anti-Freezing control for indoor heat exchanger. (Cooling and Soft Dry)

Sleep Mode Auto Control

- Indoor Fan operates at Low speed.
- Operation stops after 8 hours.

Indoor Fan Speed Control

- High, Medium and Low.
- Automatic Fan Speed Mode
 - Cooling : Fan rotates at Hi and Me speed. Deodorizing control is available.
 - Soft Dry: Fan rotates at Lo speed. Deodorizing control is available.

Airflow Direction Control

- Automatic air swing and manual adjusted by remote control for vertical airflow.
- Manually adjusted by hand for horizontal airflow.

Starting Current Control

Time Delay Safety Control

- Restarting is inhibited for approx. 3 minutes.

7 Minutes Time Save Control

- Cooling Operation only.

Outdoor Unit

CU-VC75KE / CU-VC95KE



CU-VC125KE



Compressor Reverse Rotation Protection Control

- To protect compressor from reverse rotation when there is a instantaneous power failure.

Overload Protector

- 2-Stage OLP to protect the compressor. Overload Protector will trip when
 - Temperature of compressor increases to 120°C.
 - High temperature or high current flows to compressor.
(Refer circuit diagram for OLP characteristic)



60 Secs. Forced Operation Control

- Once the compressor is activated, it does not stop within the first 60 secs. However, it stops immediately with remote control stop signal.

Outdoor Fan Operation Control

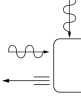
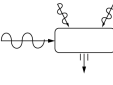

- Inner protector.

3 Product Specifications

		Unit	CS-VC75KE	CU-VC75KE	
Cooling Capacity		kW kcal/h	2.12 1820		
Moisture Removal		l/h Pint/h	1.4 3.0		
Power Source		Phase V Cycle	Single 230 50		
Airflow Method		OUTLET  INTAKE 	SIDE VIEW 	TOP VIEW 	
Air Volume	Indoor Air (Lo)	m ³ /min (cfm)	5.5 (190)	—	
	Indoor Air (Me)	m ³ /min (cfm)	5.8 (200)	—	
	Indoor Air (Hi)	m ³ /min (cfm)	7.0 (250)	—	
	Indoor Air (SHi)	m ³ /min (cfm)	7.8 (280)	—	
Noise Level		dB (A)	High 33, Low 26	High 44	
		Power level dB	High 46	High 59	
Electrical Data	Input	W	620		
	Running Current	A	3.1		
	EER	W/W (kcal/hw)	3.42 (2.94)		
	Starting Current	A	13.0		
Piping Connection Port (Flare piping)		inch inch	G ; Half Union 3/8" L ; Half Union 1/4"	G ; 3-way valve 3/8" L ; 2-way valve 1/4"	
Pipe Size (Flare piping)		inch inch	G ; (gas side) 3/8" L ; (liquid side) 1/4"	G ; (gas side) 3/8" L ; (liquid side) 1/4"	
Drain Hose	Inner diameter	mm	12	—	
	Length	m	0.7	—	
Power Cord Length		m	2.0	—	
Number of core-wire			3 (1.0 mm ²)	—	
Dimensions	Height	inch (mm)	10 - 31/32 (279)	18 - 29/32 (480)	
	Width	inch (mm)	31 - 15/32 (799)	30 - 23/32 (780)	
	Depth	inch (mm)	7 - 27/32 (199)	9 - 21/32 (245)	
Net Weight		lb (kg)	20 (9.0)	64 (29)	
Compressor	Type		—	Rotary (1 cylinder) rolling piston type	
	Motor Type		—	Induction (2-poles)	
	Rated Output	W	—	550	
Air Circulation	Type		Cross-flow Fan	Propeller Fan	
	Material		AS + Glass Fiber 30%	AES + Glass Fiber 16%	
	Motor Type		Induction (4-poles)	Induction (6-poles)	
	Input	W	20.6	48.9	
	Rate Output	W	10	20	
	Fan Speed	Low	rpm	820	—
		Medium	rpm	855	—
		High	rpm	1040	700
SuperHigh		rpm	1160	—	

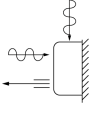
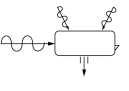

Heat Exchanger	Description		Evaporator	Condenser
	Tube material		Copper	Copper
	Fin material		Aluminium (Pre Coat)	Aluminium
	Fin Type		Slit Fin	Louver Fin
	Row / Stage		(Plate fin configuration, forced draft)	
	FPI		2 x 14	1 x 18
	Size (W x H x L)	mm	614 x 294 x 25.4	856 x 457.2 x 22
Refrigerant Control Device			—	Capillary Tube
Refrigeration Oil		(c.c)	—	RB68A (300)
Refrigerant (R410A)		g (oz)	—	655 (23.1)
Thermostat			Electronic Control	—
Protection Device			—	2 Stage Overload Protector
Capillary Tube	Length	mm	—	920
	Flow Rate	l/min	—	9.5
	Inner Diameter	mm	—	1.5
Air Filter	Material Style	(c.c)	P.P. Honeycomb	—
Capacity Control			Capillary Tube	
Compressor Capacitor		μ F, VAC	—	15 μ F, 440VAC
Fan Motor Capacitor		μ F, VAC	1.5 μ F, 400VAC	1.2 μ F, 400VAC

- Specifications are subject to change without notice for further improvement.

		Unit	CS-VC95KE	CU-VC95KE	
Cooling Capacity		kW kcal/h	2.75 2,360		
Moisture Removal		l/h Pint/h	1.6 3.4		
Power Source		Phase V Cycle	Single 230 50		
Airflow Method		OUTLET  INTAKE 	SIDE VIEW 	TOP VIEW 	
Air Volume	Indoor Air (Lo)	m ³ /min (cfm)	6.3 (220)	—	
	Indoor Air (Me)	m ³ /min (cfm)	7.5 (260)	—	
	Indoor Air (Hi)	m ³ /min (cfm)	8.5 (300)	—	
	Indoor Air (SHi)	m ³ /min (cfm)	10.0 (350)	—	
Noise Level		dB (A)	High 35, Low 26	High 46	
		Power level dB	High 48	High 61	
Electrical Data	Input	W	820		
	Running Current	A	3.6		
	EER	W/W (kcal/hw)	3.35 (2.88)		
	Starting Current	A	20.0		
Piping Connection Port (Flare piping)		inch inch	G ; Half Union 3/8" L ; Half Union 1/4"	G ; 3-way valve 3/8" L ; 2-way valve 1/4"	
Pipe Size (Flare piping)		inch inch	G ; (gas side) 3/8" L ; (liquid side) 1/4"	G ; (gas side) 3/8" L ; (liquid side) 1/4"	
Drain Hose	Inner diameter	mm	12	—	
	Length	m	0.7	—	
Power Cord Length		m	2.0	—	
Number of core-wire			3 (1.0 mm ²)	—	
Dimensions	Height	inch (mm)	10 - 31/32 (279)	18 - 29/32 (480)	
	Width	inch (mm)	31 - 15/32 (799)	30 - 23/32 (780)	
	Depth	inch (mm)	7 - 27/32 (199)	9 - 21/32 (245)	
Net Weight		lb (kg)	20 (9.0)	68 (31)	
Compressor	Type		—	Rotary (1 cylinder) rolling piston type	
	Motor Type		—	Induction (2-poles)	
	Rated Output	W	—	700	
Air Circulation	Type		Cross-flow Fan	Propeller Fan	
	Material		AS + Glass Fiber 30%	AES + Glass Fiber 16%	
	Motor Type		Induction (4-poles)	Induction (6-poles)	
	Input	W	28.3	48.9	
	Rate Output	W	15	20	
	Fan Speed	Low	rpm	830	—
		Medium	rpm	995	—
		High	rpm	1125	700
SuperHigh		rpm	1330	—	

Heat Exchanger	Description		Evaporator	Condenser
	Tube material		Copper	Copper
	Fin material		Aluminium (Pre Coat)	Aluminium
	Fin Type		Slit Fin	Louver Fin
	Row / Stage		(Plate fin configuration, forced draft)	
	FPI		2 x 14	1 x 18
Size (W x H x L)	mm	614 x 294 x 25.4	856 x 457.2 x 22	
Refrigerant Control Device			—	Capillary Tube
Refrigeration Oil	(c.c)		—	RB68A (350)
Refrigerant (R410A)	g (oz)		—	870 (30.7)
Thermostat			Electronic Control	—
Protection Device			—	2 Stage Overload Protector
Capillary Tube	Length	mm	—	590
	Flow Rate	l/min	—	8.2
	Inner Diameter	mm	—	1.3
Air Filter	Material Style	(c.c)	P.P. Honeycomb	—
Capacity Control			Capillary Tube	
Compressor Capacitor		μ F, VAC	—	30 μ F, 370VAC
Fan Motor Capacitor		μ F, VAC	1.5 μ F, 400VAC	1.2 μ F, 400VAC

- Specifications are subject to change without notice for further improvement.

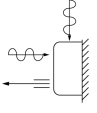
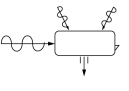
		Unit	CS-VC125KE	CU-VC125KE	
Cooling Capacity		kW kcal/h	3.65 3,140		
Moisture Removal		l/h Pint/h	2.1 4.4		
Power Source		Phase V Cycle	Single 230 50		
Airflow Method		OUTLET  INTAKE 	SIDE VIEW 	TOP VIEW 	
Air Volume	Indoor Air (Lo)	m ³ /min (cfm)	6.4 (230)	—	
	Indoor Air (Me)	m ³ /min (cfm)	8.0 (280)	—	
	Indoor Air (Hi)	m ³ /min (cfm)	9.0 (320)	—	
	Indoor Air (SHi)	m ³ /min (cfm)	9.6 (340)	—	
Noise Level		dB (A)	High 39, Low 29	High 49	
		Power level dB	High 52	High 64	
Electrical Data	Input	kW	1.26		
	Running Current	A	5.8		
	EER	WW (kcal/hw)	2.90 (2.49)		
	Starting Current	A	25.0		
Piping Connection Port (Flare piping)		inch inch	G ; Half Union 1/2" L ; Half Union 1/4"	G ; 3-way valve 1/2" L ; 2-way valve 1/4"	
Pipe Size (Flare piping)		inch inch	G ; (gas side) 1/2" L ; (liquid side) 1/4"	G ; (gas side) 1/2" L ; (liquid side) 1/4"	
Drain Hose	Inner diameter	mm	12	—	
	Length	m	0.7	—	
Power Cord Length		m	2.0	—	
Number of core-wire			3 (1.0 mm ²)	—	
Dimensions	Height	inch (mm)	10 - 31/32 (279)	19 - 7/8 (505)	
	Width	inch (mm)	31 - 15/32 (799)	30 - 23/32 (780)	
	Depth	inch (mm)	7 - 27/32 (199)	9 - 21/32 (245)	
Net Weight		lb (kg)	20 (9.0)	79 (36)	
Compressor	Type		—	Rotary (1 cylinder) rolling piston type	
	Motor Type		—	Induction (2-poles)	
	Rated Output	W	—	1,100	
Air Circulation	Type		Cross-flow Fan	Propeller Fan	
	Material		AS + Glass Fiber 30%	AES + Glass Fiber 16%	
	Motor Type		Induction (4-poles)	Induction (6-poles)	
	Input	W	28.7	60.7	
	Rate Output	W	15	20	
	Fan Speed	Low	rpm	890	—
		Medium	rpm	1125	—
		High	rpm	1260	730
SuperHigh		rpm	1340	—	

Heat Exchanger	Description		Evaporator	Condenser
	Tube material		Copper	Copper
	Fin material		Aluminium (Pre Coat)	Aluminium
	Fin Type		Slit Fin	Louver Fin
	Row / Stage		(Plate fin configuration, forced draft)	
	FPI		2 x 14	1 x 19
Size (W x H x L)	mm	614 x 294 x 25.4	776.2 x 482.6 x 22	
Refrigerant Control Device			—	Capillary Tube
Refrigeration Oil	(c.c)		—	RB68A (430)
Refrigerant (R410A)	g (oz)		—	900 (31.8)
Thermostat			Electronic Control	—
Protection Device			—	2 Stage Overload Protector
Capillary Tube	Length	mm	—	515
	Flow Rate	l/min	—	13.0
	Inner Diameter	mm	—	1.5
Air Filter	Material Style	(c.c)	P.P. Honeycomb	—
Capacity Control			Capillary Tube	
Compressor Capacitor		μ F, VAC	—	30 μ F, 370VAC
Fan Motor Capacitor		μ F, VAC	1.5 μ F, 400VAC	1.2 μ F, 400VAC

- Specifications are subject to change without notice for further improvement.

4 Dimensions

CU-VC125KE

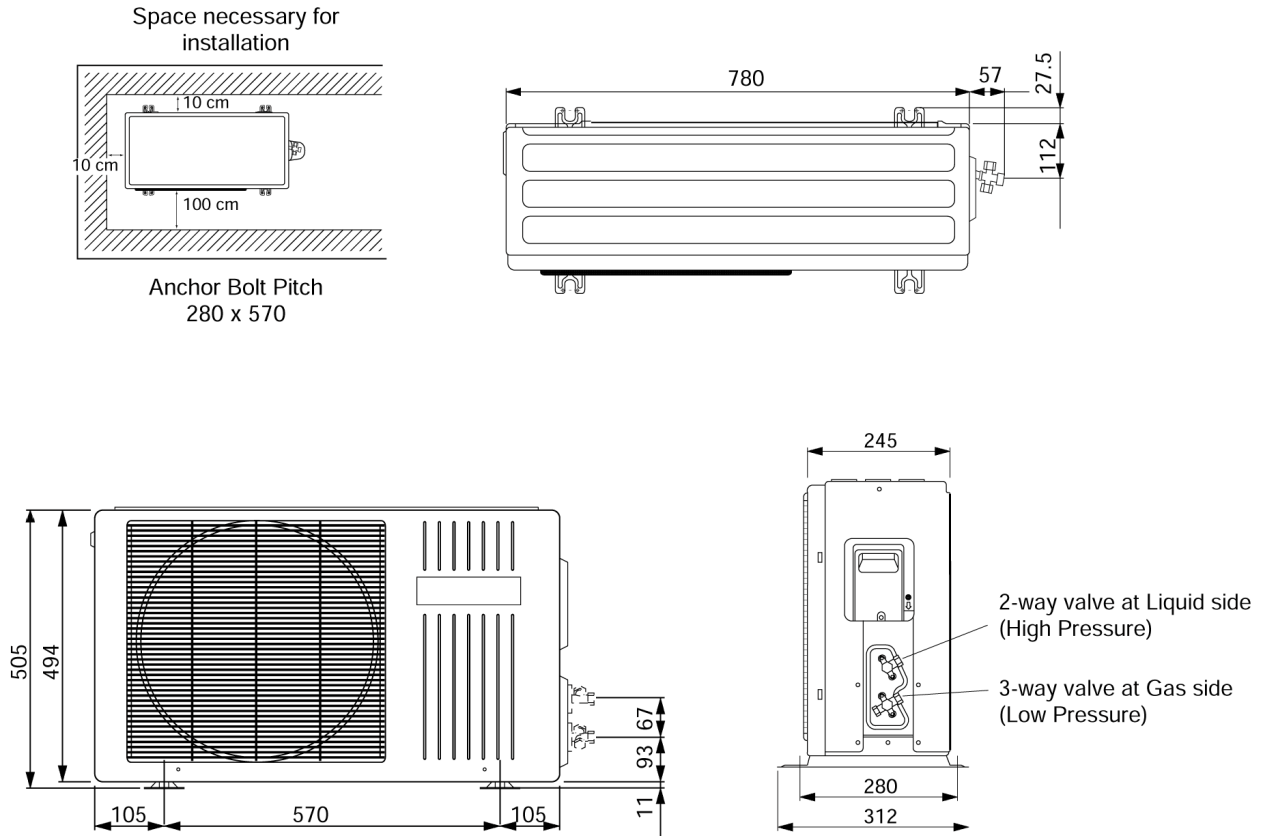

Relative position between the indoor unit and the installation plate <Front View>

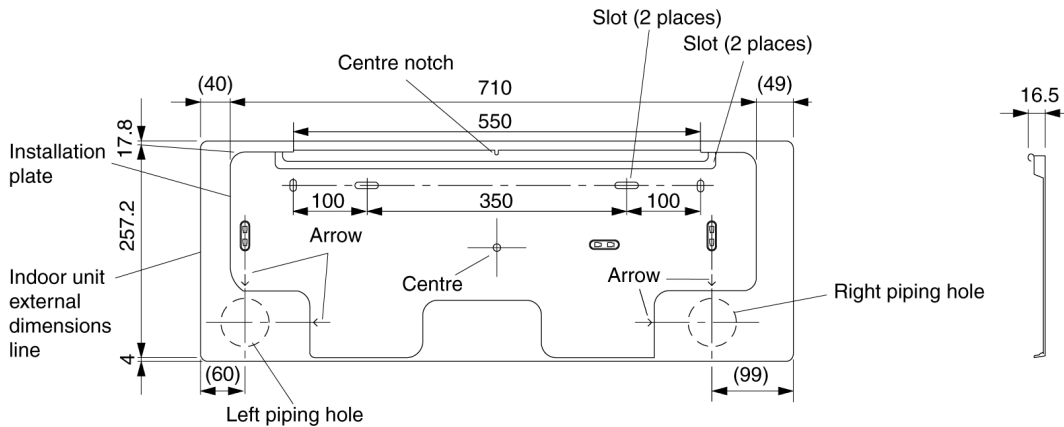

CU-VC75KE / CU-VC95KE

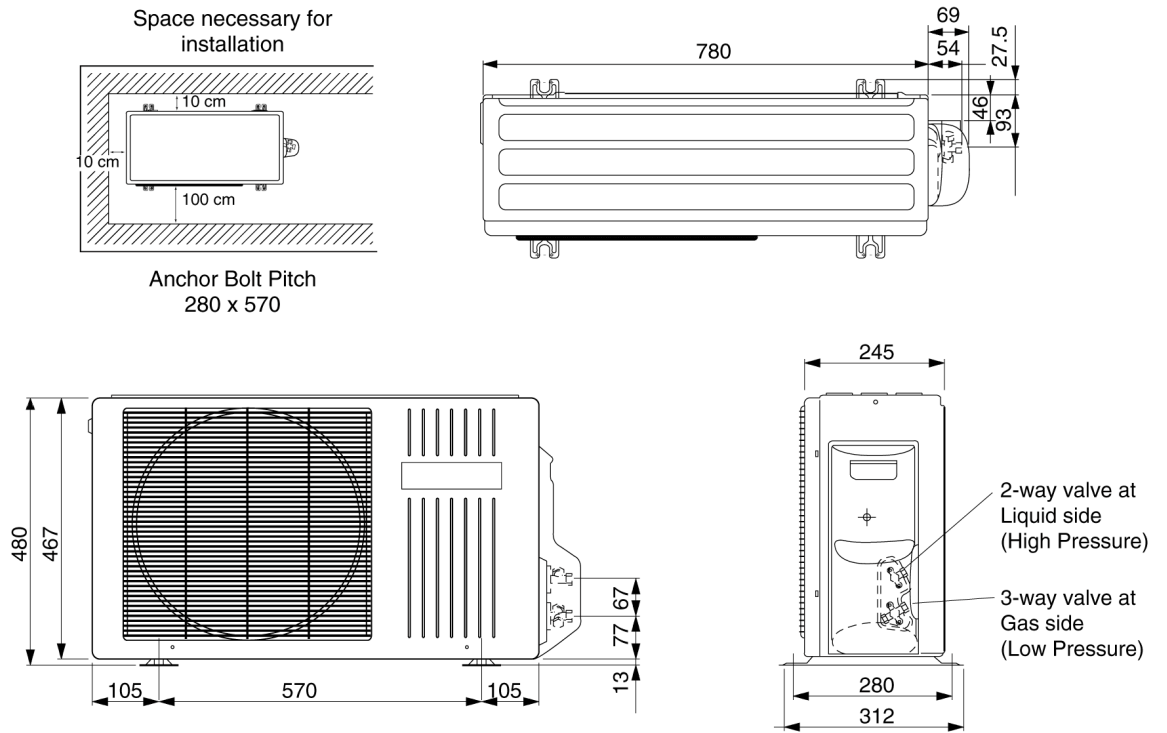

CU-VC125KE

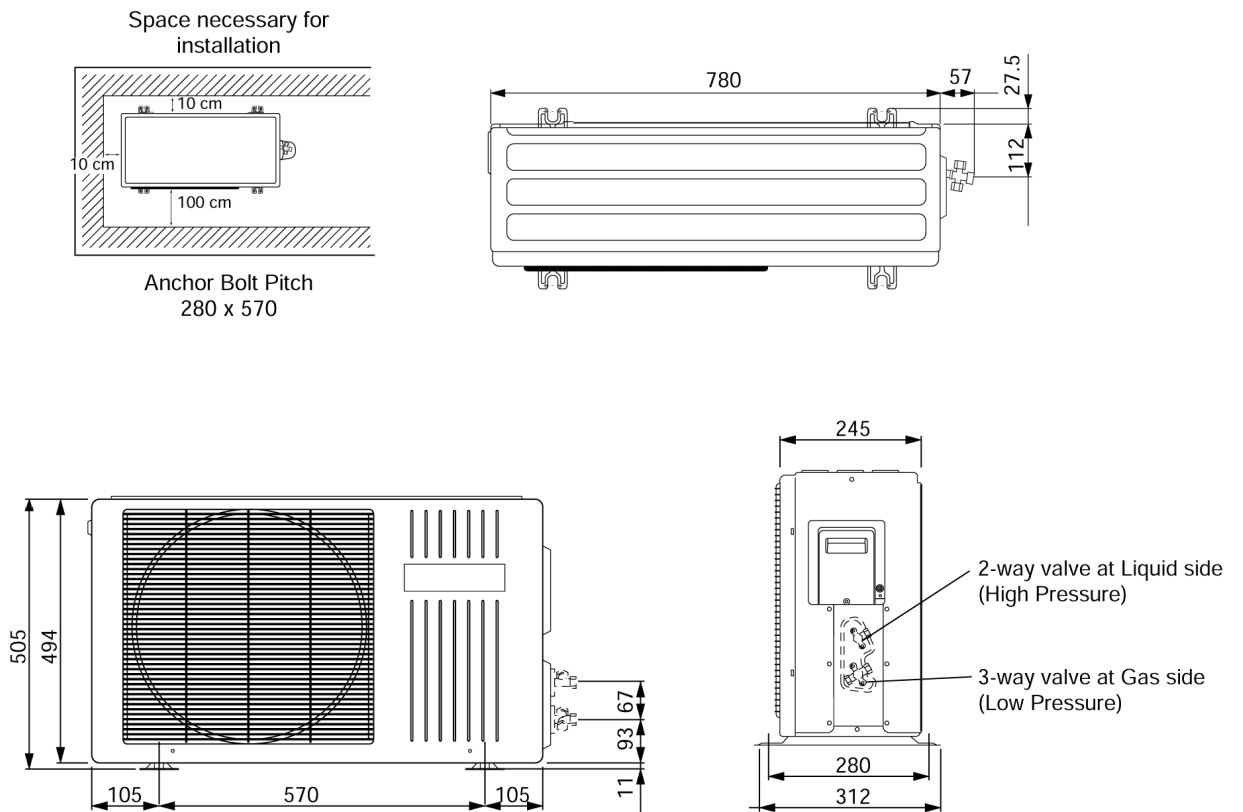

5 Refrigeration Cycle Diagram

CS-VC75KE / CU-VC75KE
CS-VC95KE / CU-VC95KE
CS-VC125KE / CU-VC125KE

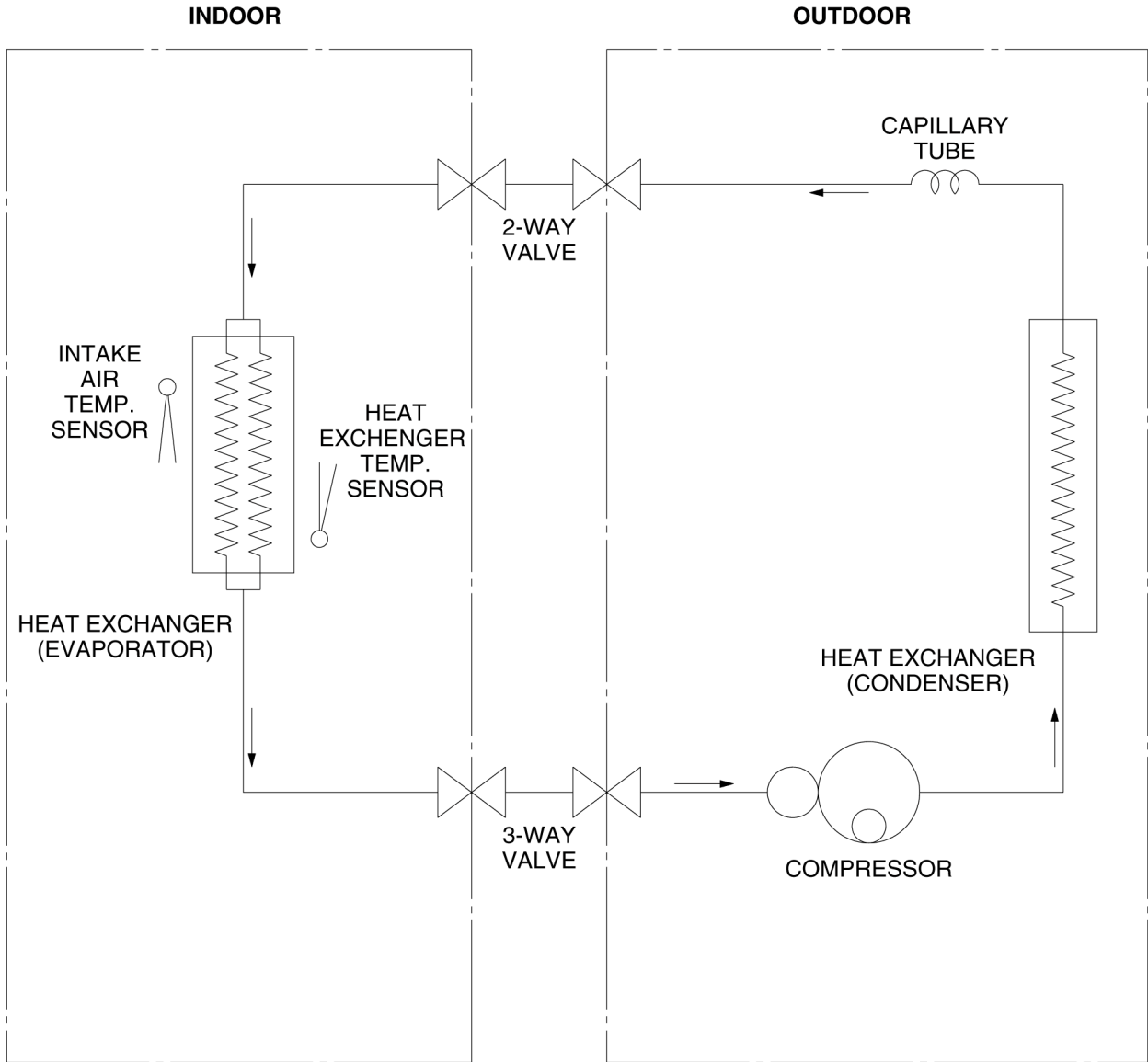

6 Block Diagram

CS-VC75KE / CU-VC75KE
 CS-VC95KE / CU-VC95KE

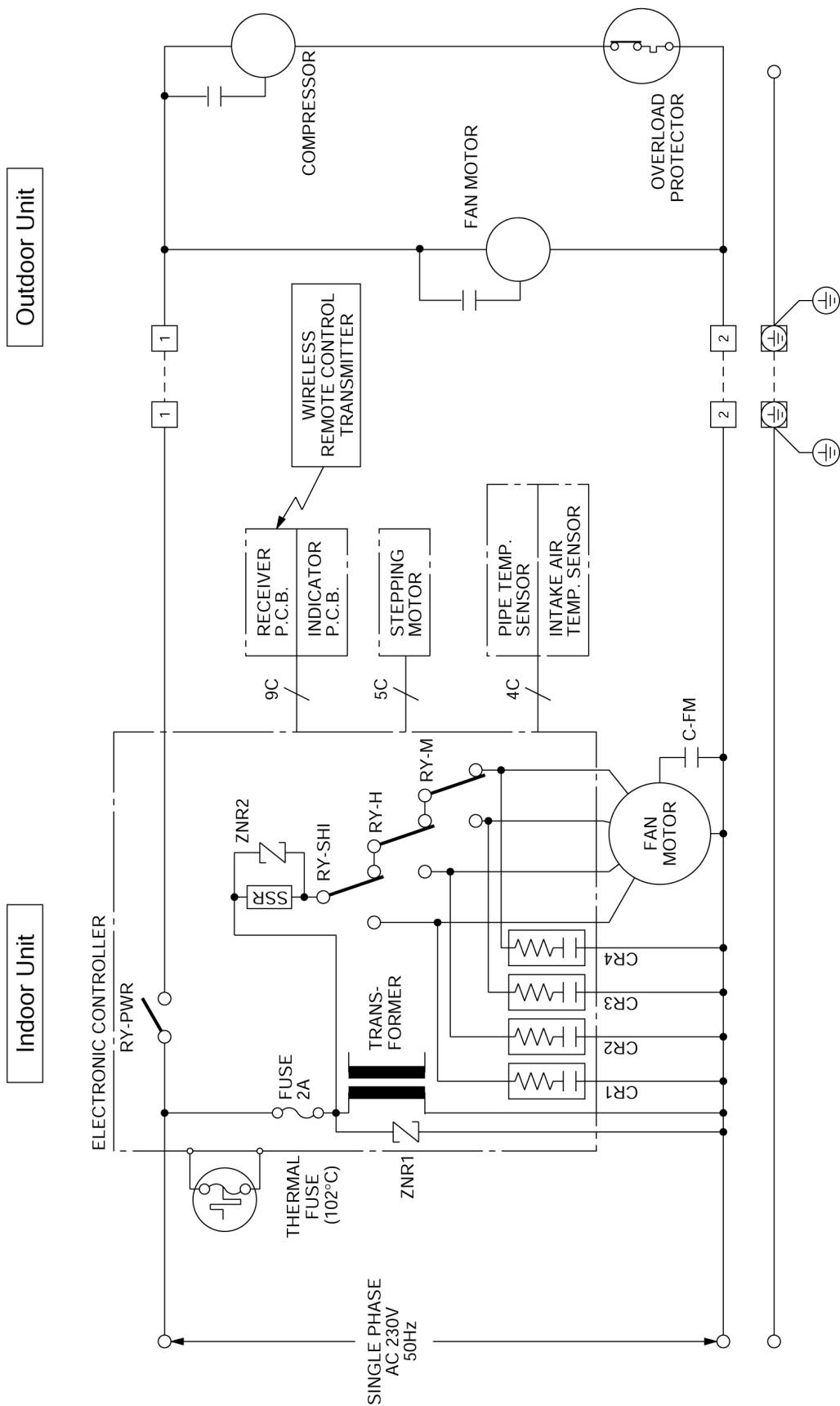

- ⊞ Indicates the electronic control unit.
- ⊞ "C" Indicates the number of core wires. (Example: 6C=6 core wires)

CS-VC125KE / CU-VC125KE

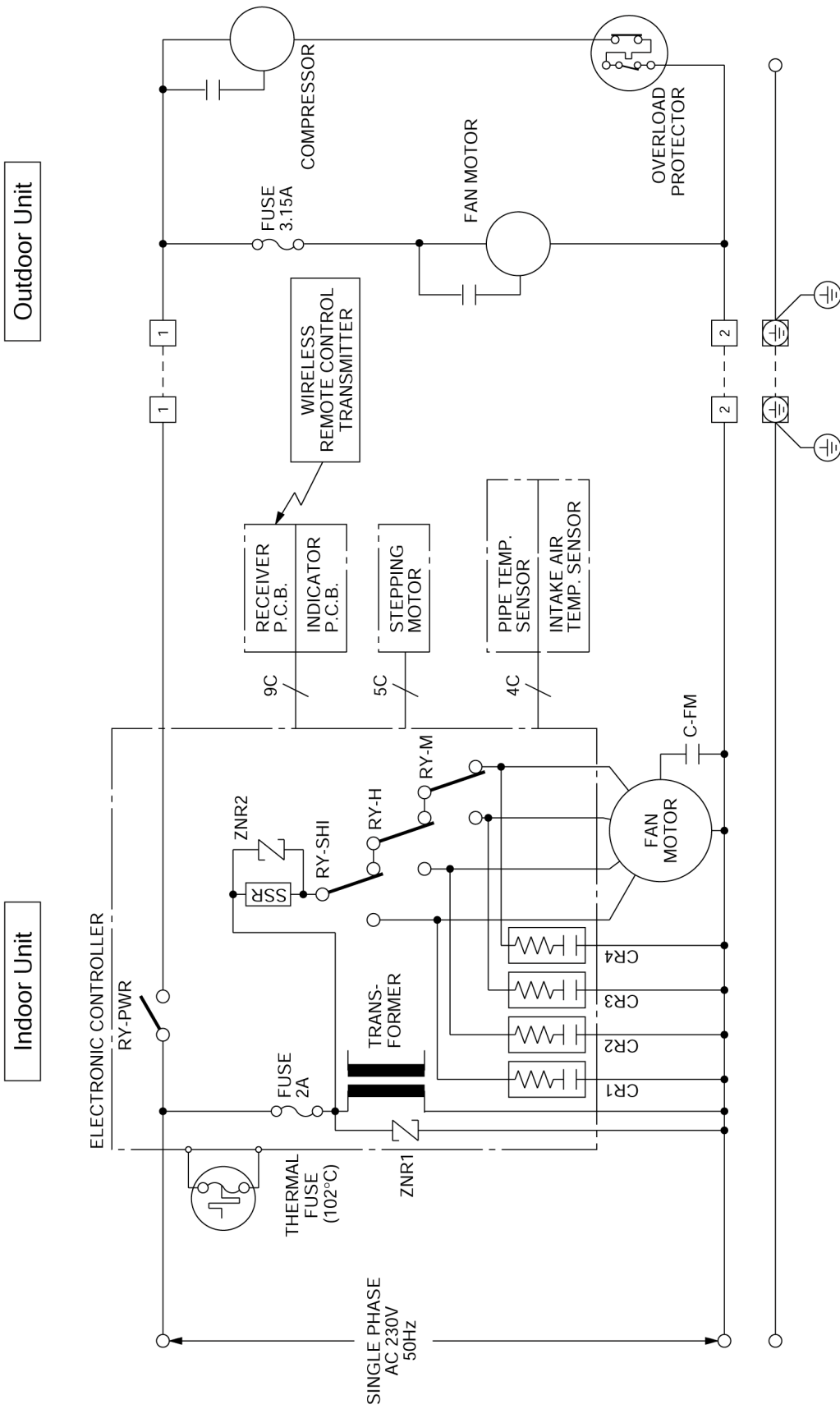

⊠ Indicates the electronic control unit.

⊠ "C" Indicates the number of core wires. (Example: 6C=6 core wires)

7 Wiring Diagram

CS-VC75KE / CU-VC75KE
CS-VC95KE / CU-VC95KE

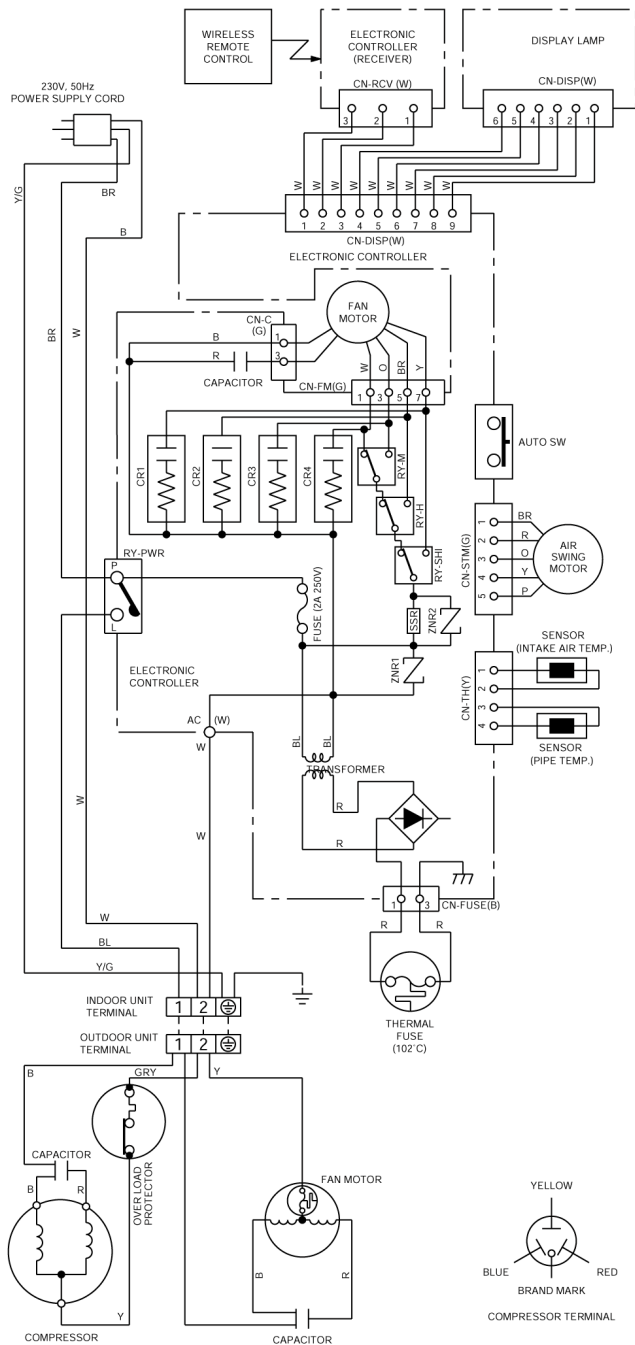

REMARKS

- B : BLUE
- BR : BROWN
- BL : BLACK
- W : WHITE
- R : RED
- O : ORANGE
- P : PINK
- Y/G : YELLOW/GREEN

Resistance of Indoor Fan Motor Windings

MODEL	CS-VC75KE	CS-VC95KE
CONNECTION	CWA921033	CWA921037
YELLOW-BLUE	536.5 Ω	462.1 Ω
YELLOW-BROWN	77.1 Ω	98.5 Ω
BROWN-ORANGE	43.9 Ω	28.8 Ω
ORANGE-WHITE	42.7 Ω	37.1 Ω
WHITE-RED	111.4 Ω	111.3 Ω

Resistance of Outdoor Fan Motor Windings

MODEL	CU-VC75KE	CU-VC95KE
CONNECTION	CWA951040	←
BLUE-YELLOW	363.7 Ω	←
YELLOW-RED	529.6 Ω	←

Resistance of Compressor Windings

MODEL	CU-VC75KE	CU-VC95KE
CONNECTION	5RS080DAA	5PS102DAA
C-R	5.807 Ω	3.863 Ω
C-S	9.304 Ω	3.309 Ω

CS-VC125KE / CU-VC125KE

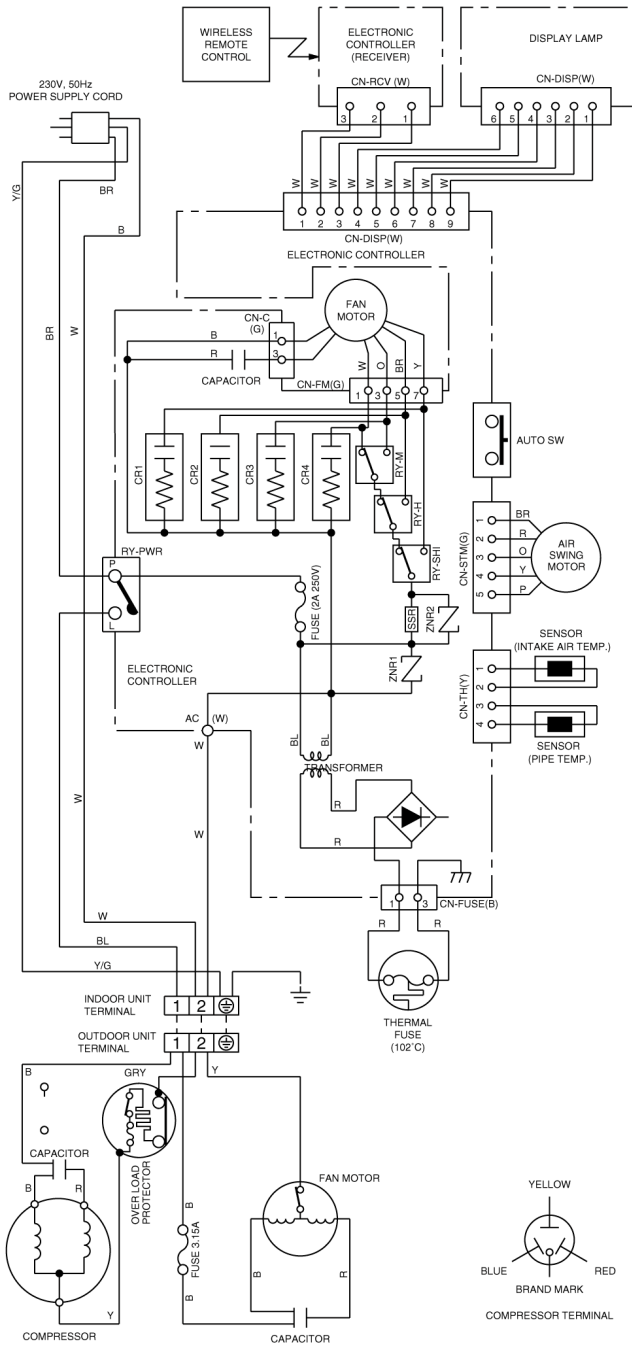

REMARKS

- B : BLUE
- BR : BROWN
- BL : BLACK
- W : WHITE
- R : RED
- O : ORANGE
- P : PINK
- Y/G : YELLOW/GREEN

Resistance of Indoor Fan Motor Windings

MODEL	CS-VC125KE
CONNECTION	CWA921031
YELLOW-BLUE	457.4 Ω
YELLOW-BROWN	56.1 Ω
BROWN-ORANGE	61.2 Ω
ORANGE-WHITE	25.3 Ω
WHITE-RED	142.5 Ω

Resistance of Outdoor Fan Motor Windings

MODEL	CU-VC125KE
CONNECTION	CWA95319
BLUE-YELLOW	260.5 Ω
YELLOW-RED	446.0 Ω

Resistance of Compressor Windings

MODEL	CU-VC125KE
CONNECTION	5RS150DAA
C-R	2.206 Ω
C-S	3.529 Ω

8 Operation Details

8.1. Cooling Mode Operation

Cooling in operation according to Remote Control setting.

Time Delay Safety Control (3 minutes)

- When the compressor is stopped by Remote Control, it restarts after 3 minutes when the Remote Control is turned ON.
- When the setting temperature is reached during cooling operation, the compressor stops and it will not start for 3 minutes.

7 minutes Time Save Control

- The compressor will start automatically if it has stopped for 7 minutes even if the room temperature is between the compressor ON temperature and OFF temperature.

Starting Current Control

- When the compressor outdoor fan motor and indoor fan motor are simultaneously started, the indoor fan motor will operate 1.6 second later.

Anti-Freezing Control

- If the temperature of the indoor heat exchanger falls continuously below 2°C for 4 minutes or more, the compressor turns off to protect the indoor heat exchanger from freezing. The fan speed setting remains the same.
- Compressor will restart again when the indoor heat exchanger temperature rises to 10°C (Recovery).
- ✕ 3 minutes waiting of Time Delay Safety Control is valid for Cooling Operation.

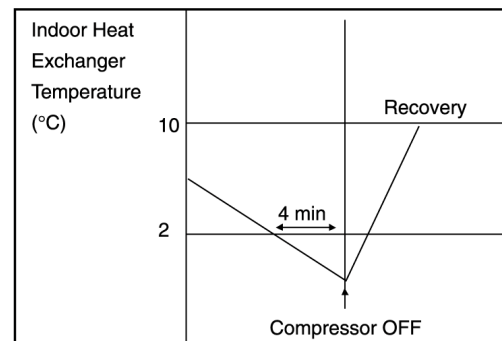

Compressor Reverse Rotation Protection Control

- If the compressor is operating continuously for 5 minutes or longer and the temperature difference between intake air and indoor heat exchanger is 2.5°C or less for 2 minutes, compressor will stop and restart automatically. (Time Delay Safety Control is valid)

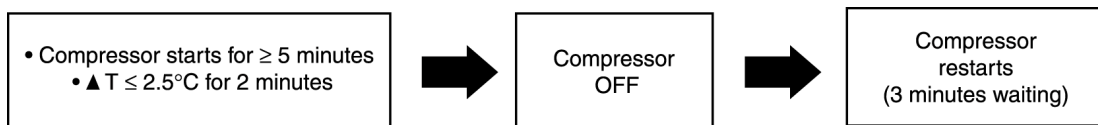

s T = Intake air temperature - Indoor heat exchanger temperature

This is to protect reverse rotation of the compressor when there is a instantaneous power failure.

Automatic Fan Speed Mode

When Automatic Fan Speed is selected at Remote Control during cooling operation.

- Fan speed rotates in the range of Hi to Me.
- Deodorizing Control.

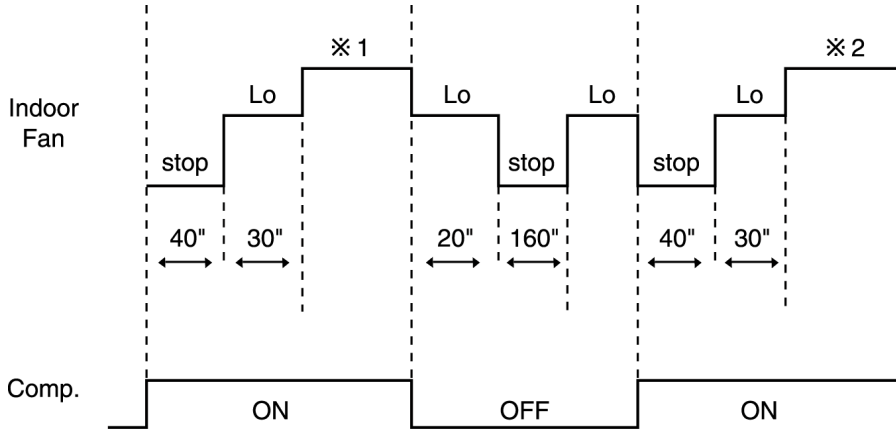

- ※ 1 Fan Speed is Hi until the compressor stops (when the room temperature reaches setting temperature).
- ※ 2 Fan Speed is Me after the compressor restarts.

Cooling Operation Time Diagram

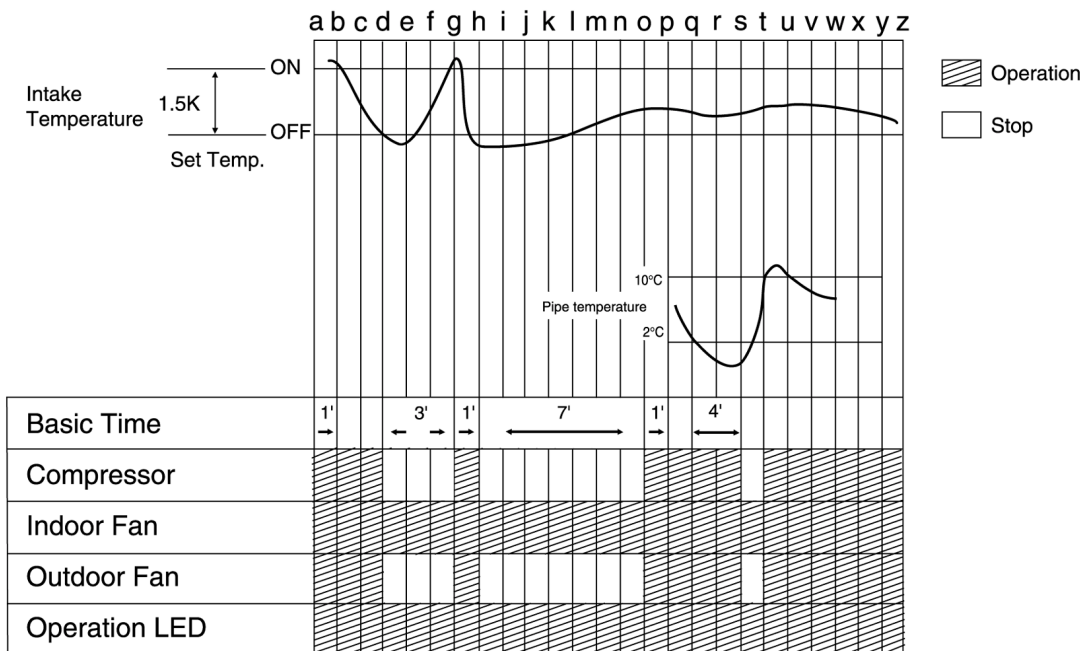

<Description of operation>

- d – g : Time Delay Safety Control (waiting for 3 minutes)
- g – h : 60 sec. Forced Operation
- h – o : 7 min. Time Saved Control
- q – t : Anti Freezing Control

8.2. Soft Dry Mode Operation

- The unit starts cooling operation until the room temperature reaches the setting temperature set on the Remote Control, and then Soft Dry operation will start.
- During Soft Dry operation, the Indoor Fan will operate at low speed.
- The operation will be switched on and off for up to 10 minutes "ON" and 6 minutes "OFF". Once Soft Dry operation is turned off, it stops for 6 minutes.

Time Delay Safety Control

- Once the compressor stops, it will not start for 3 minutes during Cooling operation.

Starting Current Control

- Same as Starting Current Control for Cooling Mode operation.

Anti-Freezing Control

- Same as Anti-Freezing Control for Cooling Mode operation. (For Soft Dry region, 6 minutes waiting is valid during compressor stops.)

Compressor Reverse Rotation Protection Control

- Same as Compressor Reverse Rotation Protection Control for Cooling Mode Operation. (For Soft Dry region, 6 minutes waiting is valid during compressor stops.)

Automatic Fan Speed Mode

When Automatic Fan Speed is selected at Remote Control during Soft Dry operation.

- Fan speed off and on at Lo speed.
- Deodorizing Control.

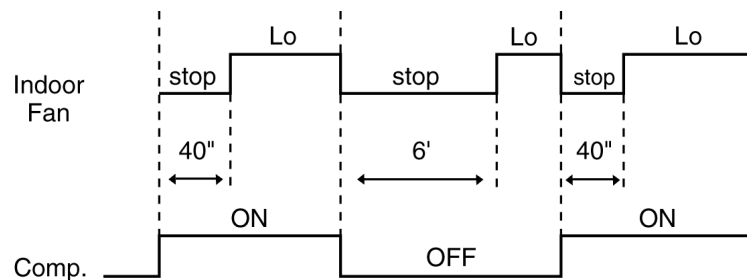

Soft Dry Operation Time Diagram

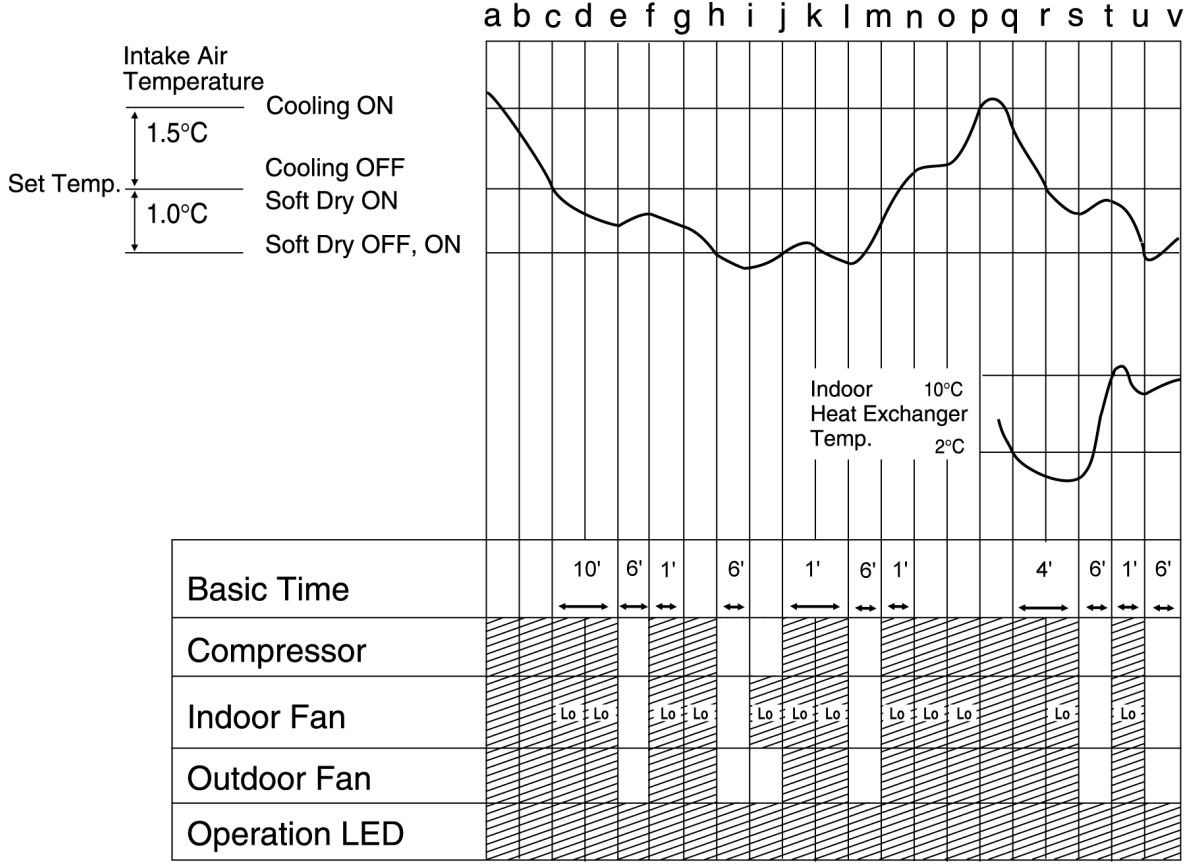

<Description of operation>

- a - c, p - r : Cooling Operation
- c - p, r - v : Soft Dry Operation
- e - f : Soft Dry OFF
- j - l : 60 sec. Forced Operation
- q - t : Anti Freezing Control

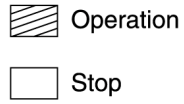

8.3. Air Circulation Mode Operation

- When the temperature near the ceiling reaches the setting temperature, Air Circulation Mode operation commences at low airflow volume. It stops when the temperature drops to 2°C below the setting temperature.

Air Circulation Mode Operation Time Diagram

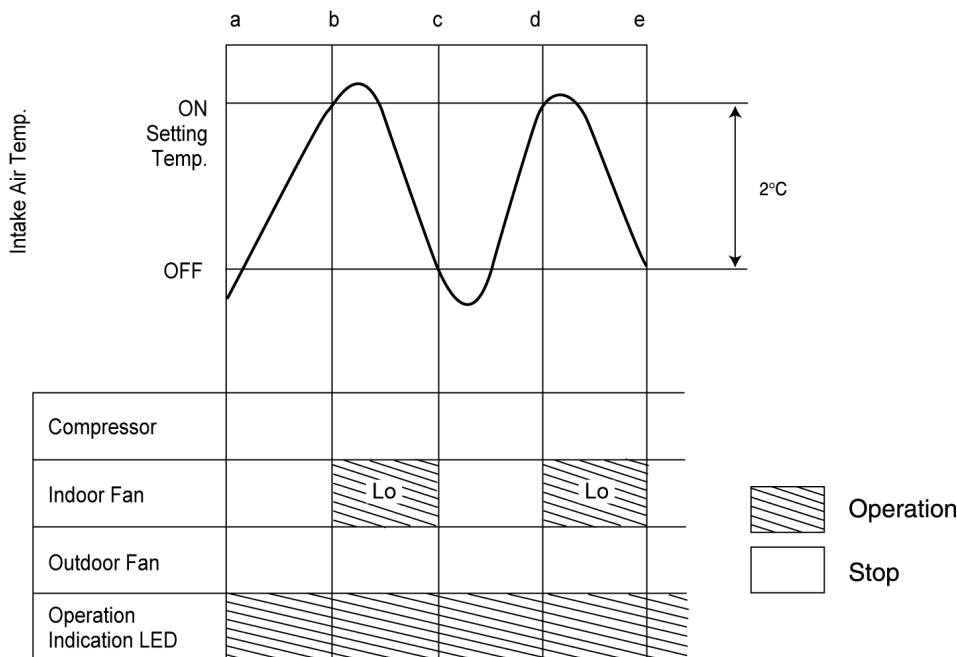

8.4. Automatic Mode Operation

Standard for Determining Operation Mode

↑
Intake Air Temperature

23°C

Cooling Mode
Soft Dry Mode

	Setting Temperature (Standard)
Cooling Mode	25°C
Soft Dry Mode	22°C

- Indoor fan operates at Lo fan speed for 20 seconds.
- After judging indoor air temperature, the operation mode is determined and operation continued at the mode determined.
- After the operation mode has been determined, the mode does not change. However, Soft Dry mode operation includes Cooling mode operation.
- Room temperature adjustment.

The following are added to the setting temperature specified as above.

		Cooling	Soft Dry
Higher	→ +2°C	27°C	24°C
Standard	→ ±0°C	25°C	22°C
Lower	→ -2°C	23°C	20°C

- The mode judging temperature and standard setting temperature can be increased by 2°C, by open the circuit of JX2 at indoor electronic controller.

↑
Intake Air Temperature

25°C

Cooling
Soft Dry

	Setting Temperature (Standard)
Cooling Mode	27°C
Soft Dry Mode	24°C

8.5. Sleep Mode Auto Operation

Cooling or Soft Dry Operation

When you press the SLEEP Mode, the following movement will start to avoid overcooling.

- When the room temperature reaches the setting temperature or after 1 hour of operation, sleep shift operation starts and the airflow volume will automatically change to low.
- The setting temperature will be risen by 0.5°C at the start of operation and by 0.5°C one hour later.
- The operation will stop after 8 hours.

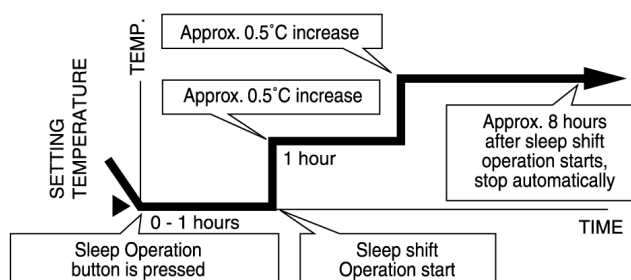

8.6. Powerful Mode Operation

- Purpose of this operation is to obtain the setting temperature quickly.
- When the Powerful Mode is set, the set temperature will be automatically decreased 3°C against the present setting temperature.

This operation automatically will be running under Super High Fan speed.

- Vertical Airflow Direction:-
 - In "Manual" setting, the vane will automatically swing down 10° lower than previous setting.
 - In "Auto" setting, the vane will automatically swing up and down. However the lower limit will be shifted 10° downward.
- Powerful Mode will operate for 15 minutes only.
- Powerful Mode will stop if:-
 - Powerful mode button is pressed again.
 - Stopped by ON / OFF switch.
 - Timer OFF activates.
 - Economy mode button is pressed.
 - Sleep mode is pressed.
 - Operation mode button is changed.

8.7. Economy Mode Operation

- Purpose of this operation is to save or reduced electrical power consumption of the room air conditioner.
- When the Economy Mode is set, the set temperature will be automatically increased 0.5°C against the preset setting temperature. This operation automatically will be running under Random Fan speed.

(Refer operation details no. 8.9)

- Vertical Airflow Direction:-
 - In "Manual" or "Auto" setting, the vane will automatically change to Auto Air Swing.
- Economy Mode will stop if:-
 - Economy Mode button is pressed again.
 - Stopped by ON / OFF switch.
 - Timer OFF activates.
 - Powerful mode button is pressed.
 - Auto or Manual air swing button is pressed.
 - Fan Speed control button is pressed.
 - Sleep Mode button is pressed ON.
 - Operation Mode is changed.

8.8. Random Auto Restart Control

- If there is a power failure, operation will be automatically restarted after 3 to 5 1/2 minutes when the power is resumed. It will start with previous operation mode and airflow direction.
- Restart time is decided randomly using 4 parameter:-
Intake air temperature, setting temperature, fan speed and Air Swing Blade position.
- Auto Restart Control is not available when Timer or Sleep Mode is set.
- This control can be omitted by open the circuit of JX1. (Refer Circuit Diagram)

8.9. Indoor Fan Speed Control

- Auto Fan Speed Control
When set to Auto Fan Speed, the fan speed is adjusted between maximum and minimum setting as shown in the table.
- Manual Fan Speed Control
Basic fan speed adjustment (3 settings, from Lo to Hi) can be carried out by using the Fan Speed selection button.

			SHi	Hi	Me	Lo	Random Speed
Cooling Mode	Manual Fan Speed	Normal		○	○	○	
		Powerful	○				
		Economy					○
	Auto Fan Speed	Normal		○	○		
		Powerful	○				
		Economy					○
Soft Dry Mode		Normal				○	
		Powerful				○	
		Economy				○	
Air Circulation Mode		Normal				○	
		Powerful					
		Economy					



Can be set by Remote Control

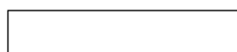

Cannot be set by Remote Control

※ Lo, Lo⁻ or Lo^{- -} Fan Speed is operated randomly during Random Fan Speed.

Random Fan Speed

The fan is turning at pattern A or B or C randomly, for an interval of 10" each during Random Fan Speed.

Random	A		B				C		
Fan Speed	LO		LO ⁻				LO ^{- -}		
Time	10"	4.5"	0.5"	4.5"	0.5"	4"	1"	4"	1"
Fan Motor	ON	ON	OFF	ON	OFF	ON	OFF	ON	OFF

8.10. Airflow Direction Control

Airflow Direction Auto-Control

- When set a Airflow Direction Auto-Control with remote control, the louver swings up and down as shown in the diagram.
- The louver does not swing when the Indoor Fan stops during operation.
- When stopped with remote control, the discharge vent is closed with the louver.

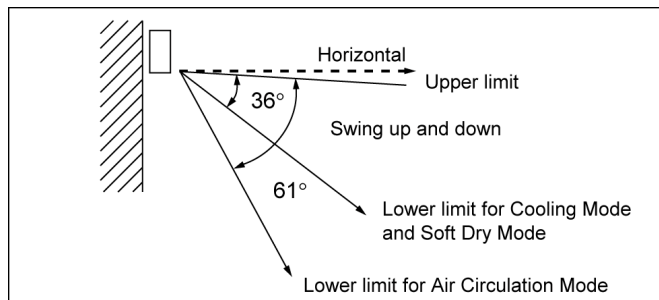

✘ The left and right airflow direction louvers can be adjusted manually.

- ✘ 1. There is no swinging while indoor fan is stopped during Cooling and Soft Dry operation.
- ✘ 2. In Air Circulation operation, when the intake air temperature reaches set temperature, the airflow direction is changed from upper limit to lower limit. When the intake air temperature falls to 2°C lower than set temperature, the airflow direction is changed from lower limit to upper limit.

Airflow Direction manual Control

- When the manual Airflow Direction Selection Button is pressed, the automatic airflow is released and the airflow direction louver move up and down in the range shown in the diagram.
The louver can be adjusted by pressing the button to the desired louver position.
- When the remote control is used to stop the operation, the discharge vent is closed with airflow direction louver.

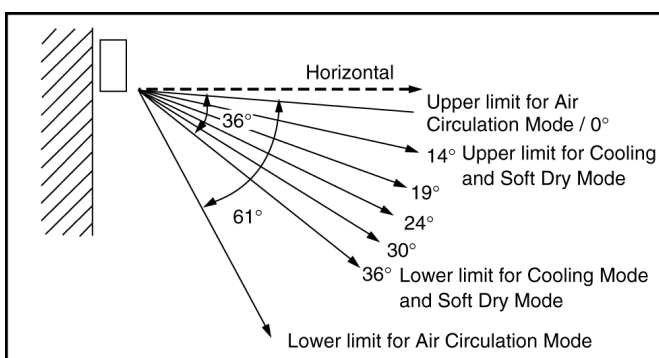

✘ The left and right airflow direction louvers can be adjusted manually.

8.11. Delay ON Timer Control

- When the Delayed ON Timer is set by using the remote control, the unit will start operate slightly before the set time, so that the room will reach nearly to the set temperature by the desired time.
- For Cooling and Soft Dry mode, the operation will start 15 minutes before the set time.
- For Automatic mode, the indoor fan will operate at Lo speed for 20 seconds, 15 minutes before the set time to detect the intake air temperature to determine the operation mode. The operation indication lamp will blink at this time.

8.12. Remote Control Signal Receiving Sound

- Long beep sound will be heard when:-
 - Stopping the Air Conditioner using ON/OFF switch.
 - Stopping the Sleep Mode.
 - Stopping the Powerful Mode.
 - Stopping the Economy Mode.
- Short beep sound will be heard for others.
- To switch off the beep sound:-
Press the "Automatic Operation Button" continuously for 10 seconds or more ("beep" "beep" will be heard at the 10th second). Repeat the above if you want to switch ON the beep sound.

✘ However, if the "Automatic Operation Button" has been pressed the Automatic cooling operation will be activated. If you do not require this operation, you may change it by using the remote control.

9 Operating Instructions

SAFETY PRECAUTIONS

Before operating, please read the following “Safety Precautions” carefully.

To prevent personal injury, injury to others and property damage, the following instructions must be followed.

- Incorrect operation due to failure to follow instructions will cause harm or damage, the seriousness of which is classified as follows :



Warning

This sign warns of death or serious injury.



Caution

This sign warns of damage to property.

- The instructions to be followed are classified by the following symbols :



This symbol (with a white background) denotes an action that is PROHIBITED.



These symbols (with a black background) denote actions that are COMPULSORY.

● Installation Precautions



Warning

- **Do not install, remove and reinstall the unit yourself.**
Improper installation will cause leakage, electric shock or fire. Please consult an authorized dealer or specialist for the installation work.



Caution

- **This room air conditioner must be earthed.**



Improper grounding could cause electric shock.

- **Do not install the unit in a place where there may be explosive gas leaks.**



Gas leaks near the unit could cause fires.

- **Ensure that the drainage piping is connected properly.**



Otherwise, water will leak out.

● Operation Precautions



Warning

This sign warns of death or serious injury.



Do not insert plug to operate the unit.
Do not pull out plug to stop the unit.



Plug in properly.



Do not share outlet.

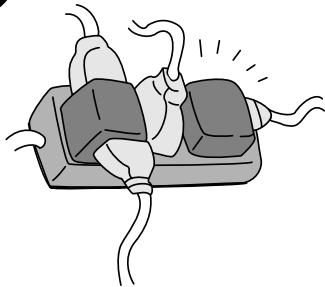

Do not operate with wet hands.



Use specified power cord.



Do not repair by yourself.

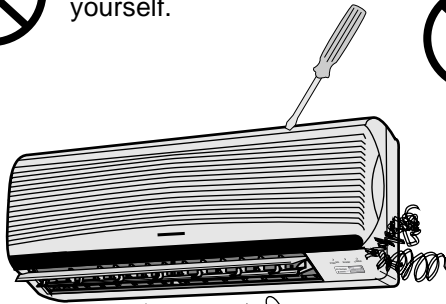

Do not damage or modify the power cord.



If abnormal condition (burnt smell, etc) occurs, switch off and unplug the power supply.



Do not insert finger or other objects into the indoor or outdoor units.

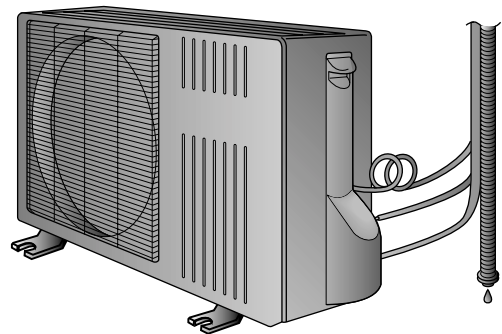
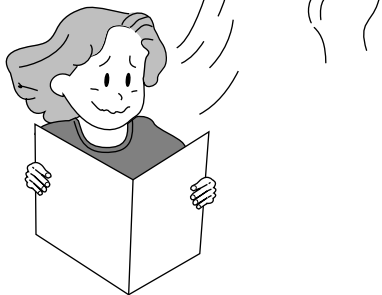

Do not exposed directly to cool air for a long period.

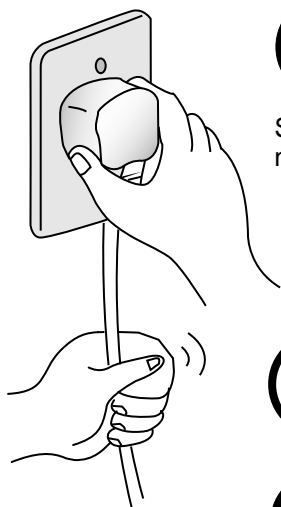

Switch off the power supply if the unit is not used for a long period.

 **Caution**
This sign warns of injury.



Do not pull the cord to disconnect the plug.



Switch off the power supply before cleaning it.

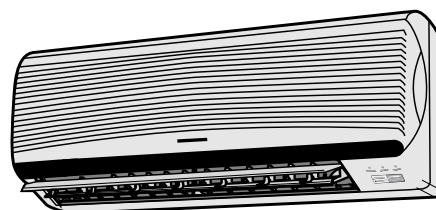

Do not wash the unit with water.

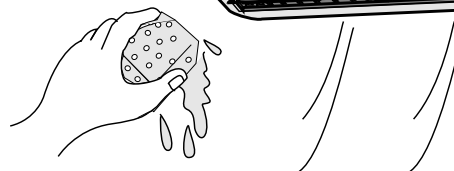

Do not use for other purpose such as preservation or etc.



Do not use any combustible equipment at airflow direction.

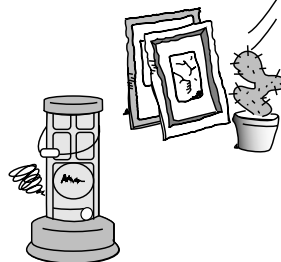

Ventilate the room regularly.



Do not sit or place anything on the outdoor unit.

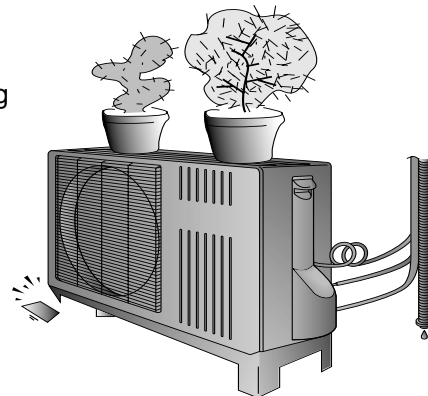

Pay attention as to whether the installation rack is damaged due to long period of usage.

NAME OF EACH PART

● Indoor Unit

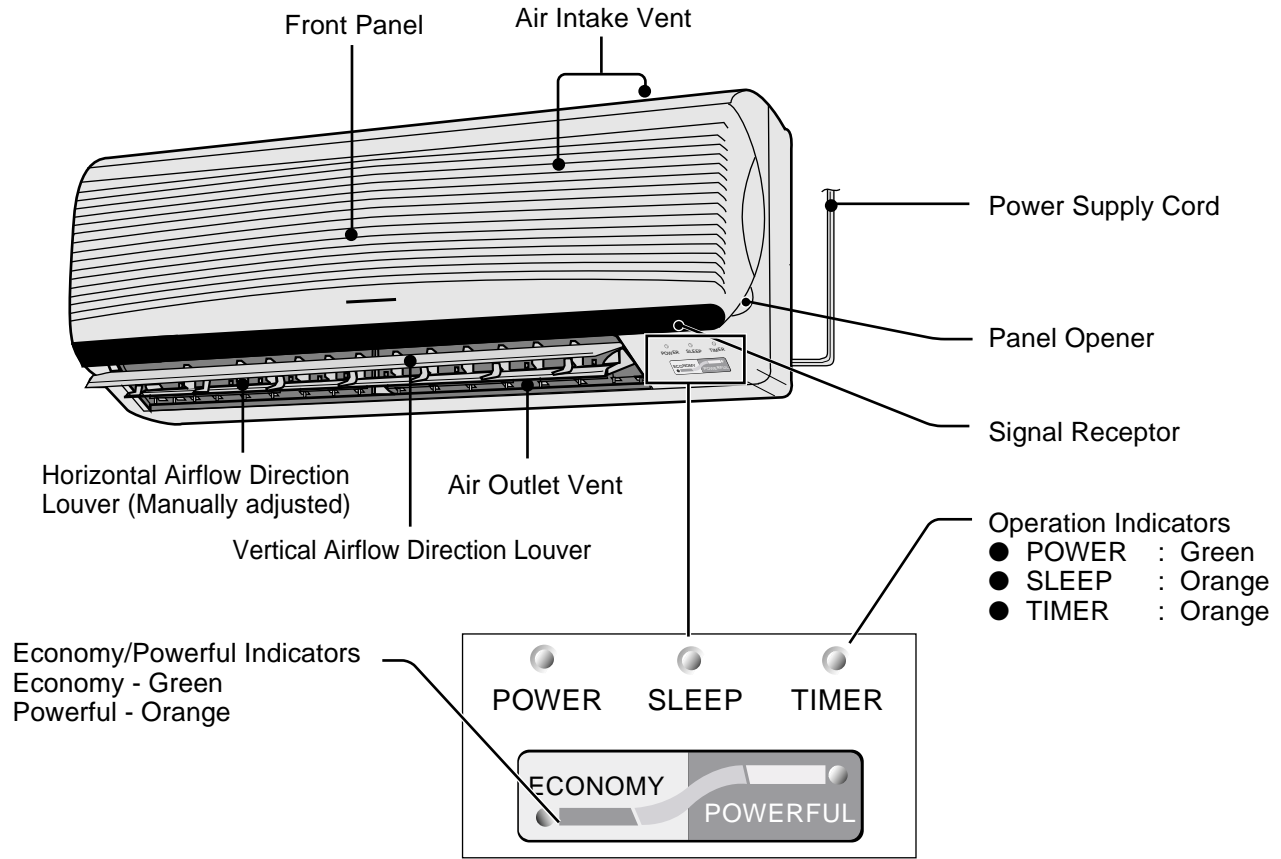

■ When the front panel is opened

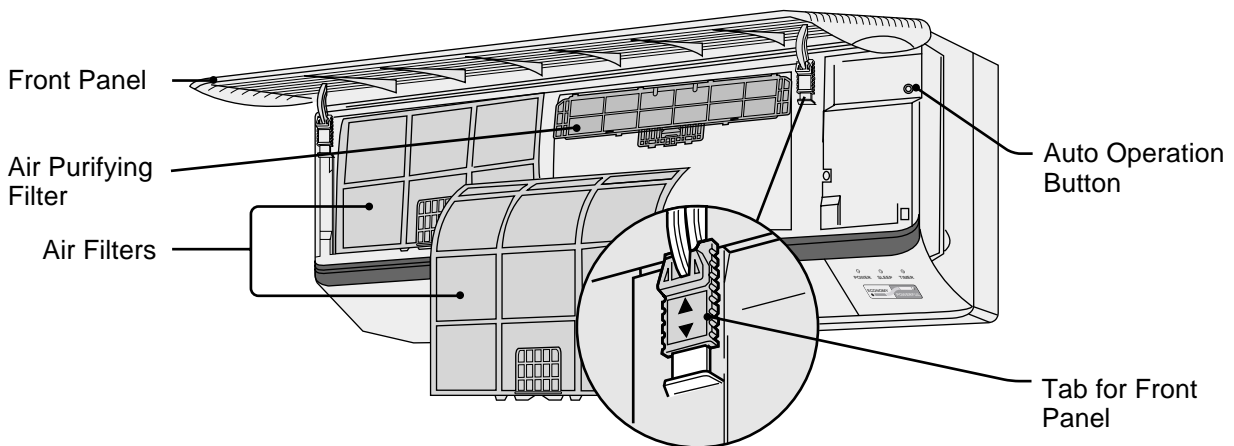

● Outdoor Unit

CU-VC75KE, CU-VC95KE

CU-VC125KE

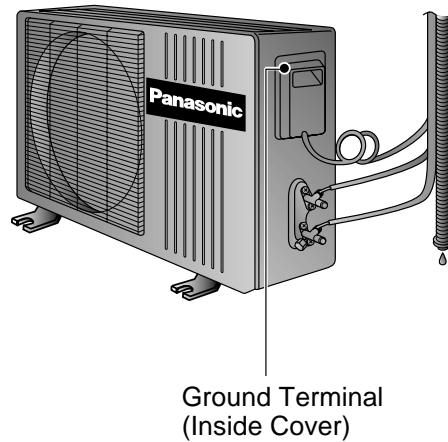
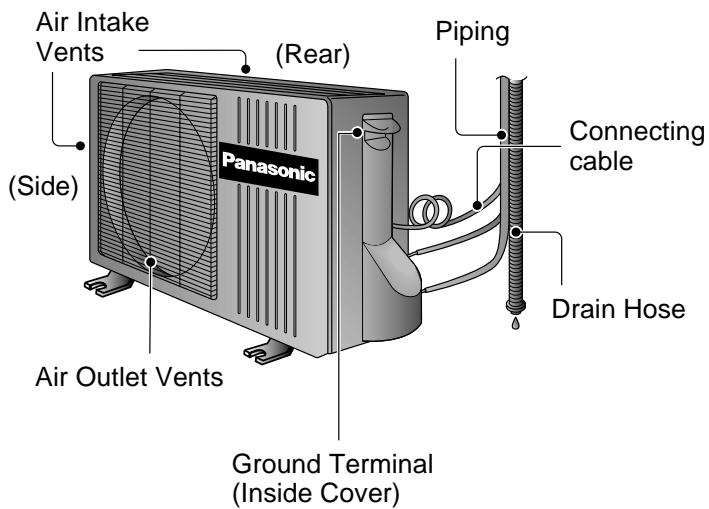

● Accessories

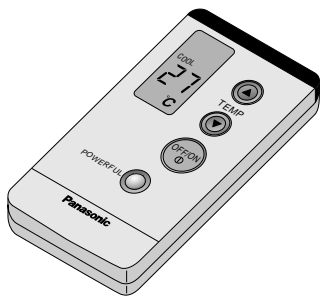

Remote Control

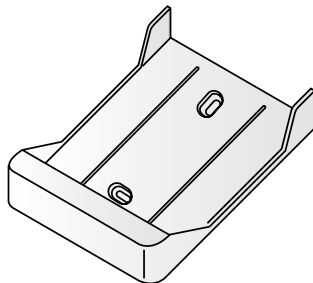

Remote Control Holder

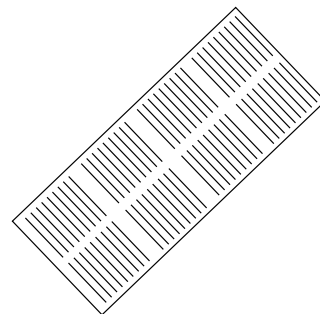

Remote Control Indication Sticker

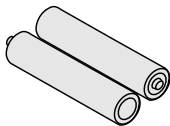

Two RO3 dry-cell batteries or equivalent

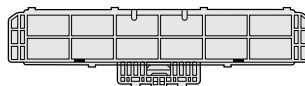
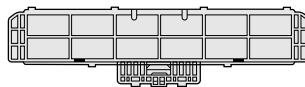

Air Purifying Filters
(Catechin Air Purifying Filters and Deodorizing Filters)

● Remote Control

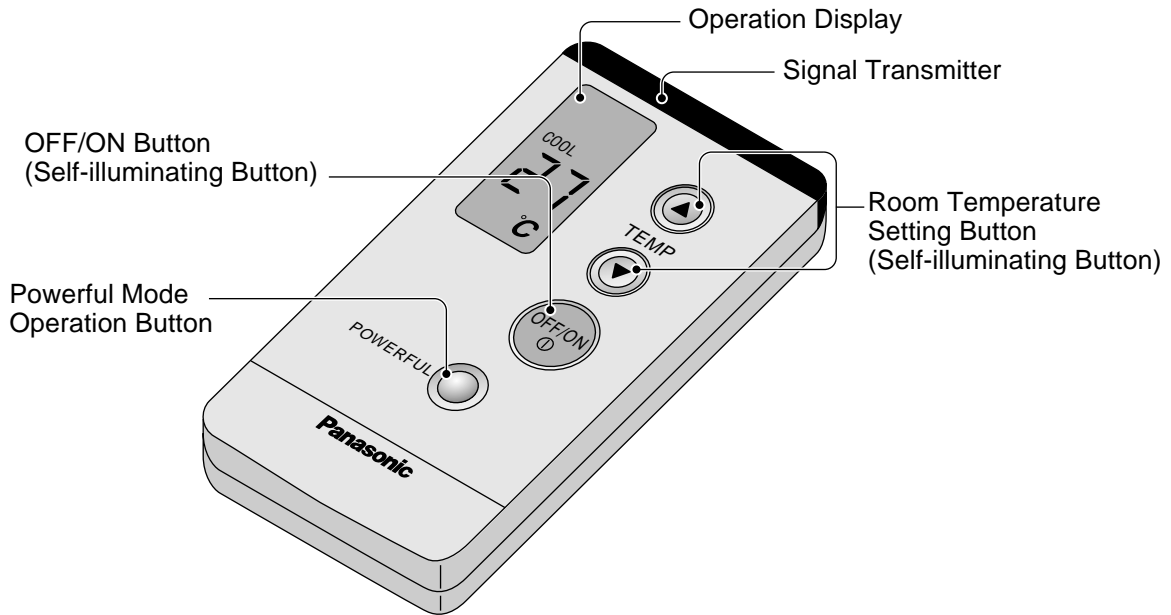

■ When the remote control cover is opened

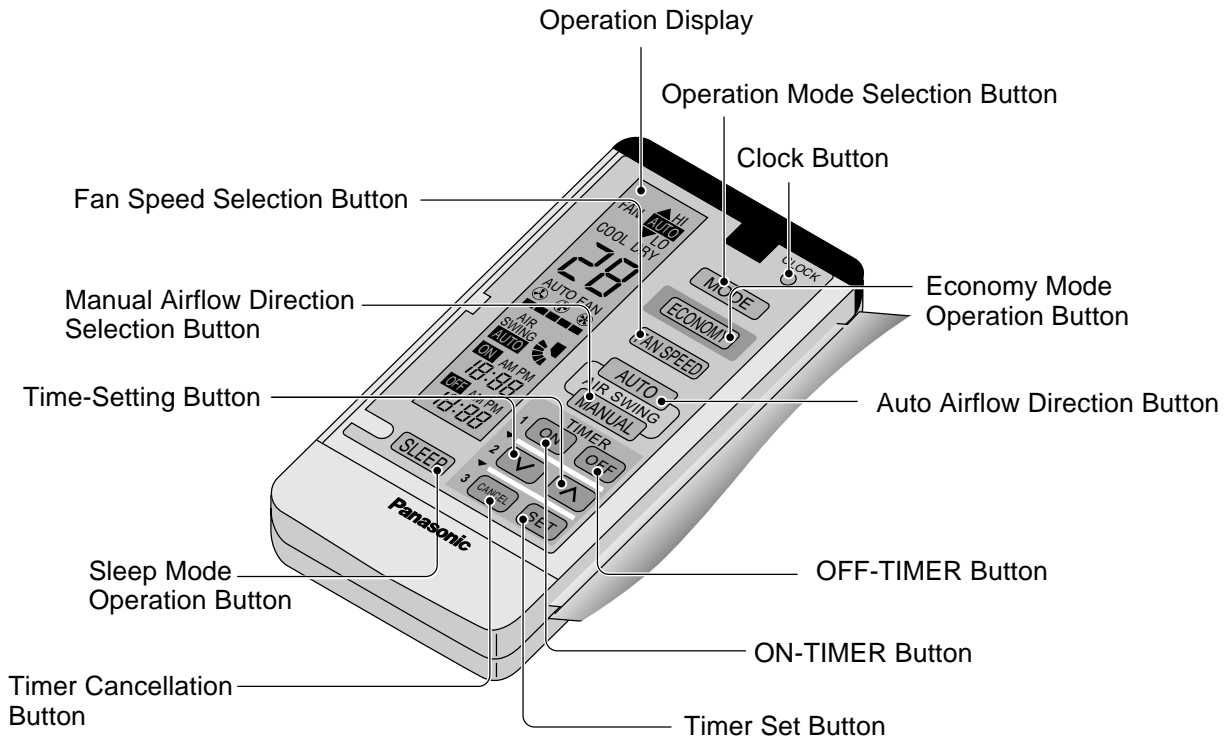

■ How to use the remote control

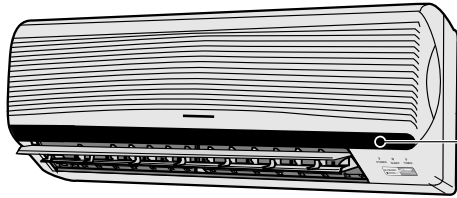

Notes

- Do not throw or drop
- Do not get it wet
- Certain type of flourescent lamps may affect signal reception. Consult your dealer.

- Signal receptor
- Signal received sound.
One short beep or one long beep.

- Maximum distance : 10 m
- Make sure it is not obstructed.

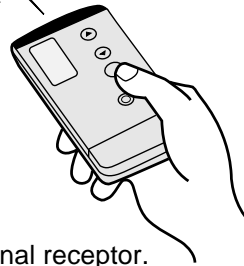

- Aim at the signal receptor.

■ When the back cover is opened

- Reset points
- short to clear the memory

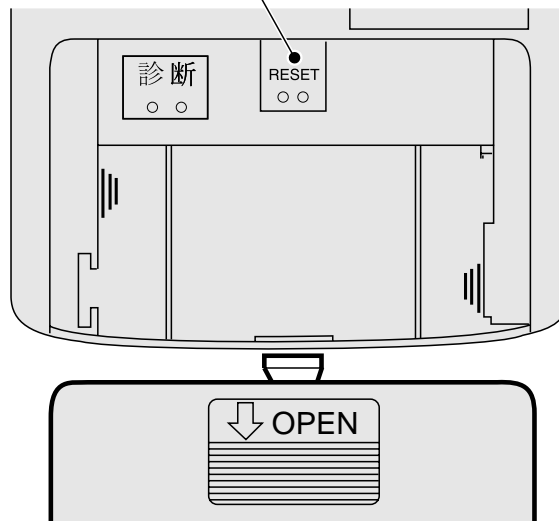

PREPARATION BEFORE OPERATION

● Indoor Unit



Warning

- **Ensure the power plug is securely inserted.**
A loose plug may cause a fire or an electric shock.

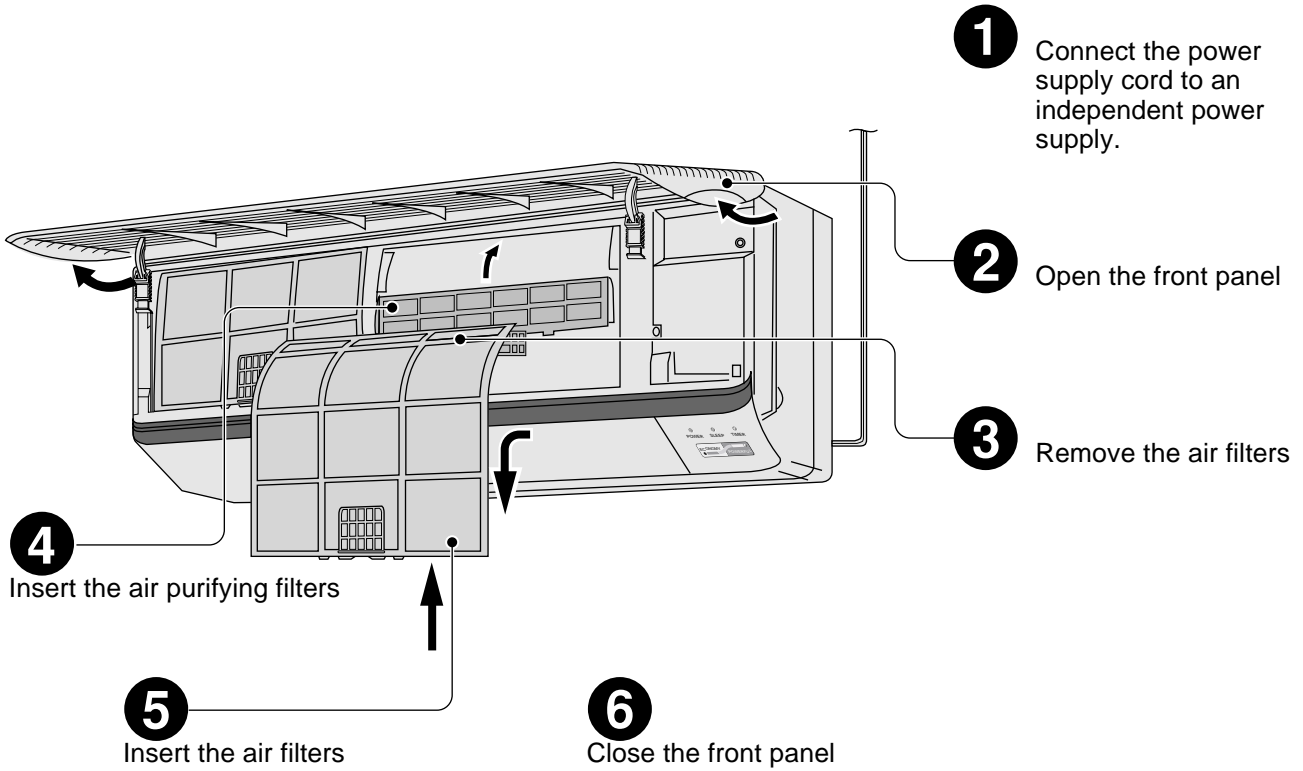

■ Notes

- If the unit is not going to be used for an extended period of time, turn off the main Power supply. If it is left at the ON position, approximately 2.5 W of electricity will be used even if the indoor unit has been turned off with the remote control.
- If operation is stopped, then restart immediately, the unit will resume operation only after 3 minutes.

Use under the following conditions				(Unit in °C)			
DBT: Dry Bulb Temp	Indoor		Outdoor				
	DBT	WBT	DBT	WBT			
WBT: Wet Bulb Temp							
Maximum Temperature	32	23	43	26			
Minimum Temperature	16	11	16	11			

● Remote Control
 ■ Inserting batteries

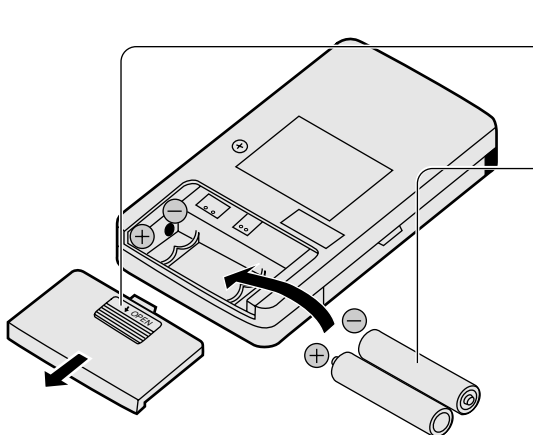

1 Slide the cover to open

2 Be sure the directions are correct

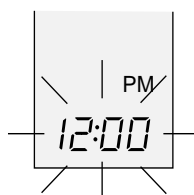

- Open the remote control cover and confirm the display 12:00 PM is flashing.

※ Set the current time (Clock) immediately to prevent battery exhaustion.

■ Setting the clock

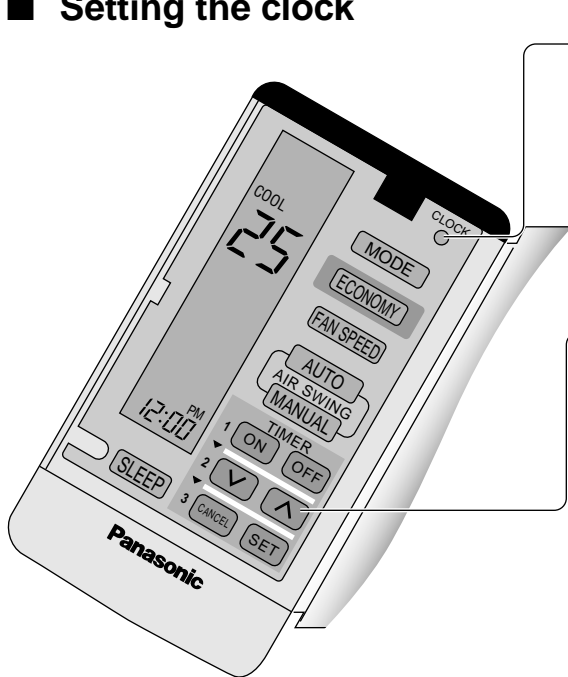

1 Press the clock button

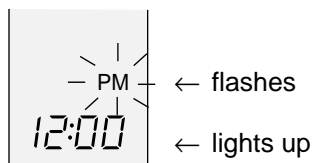

2 Press to set the current time

Press continuously for fast forwarding.

Press continuously for fast reversing.

3 Press the clock button

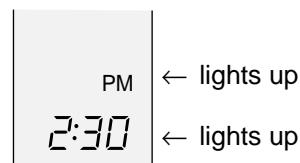

■ About the batteries

- Can be used for approximately one year.

Observe the following when replacing the batteries

- Replace with new batteries of the same type .
- Do not use rechargeable batteries (Ni-Cd).
- Remove the batteries if the unit is not going to be used for a long period.

HOW TO OPERATE

● Automatic, Cooling, Soft Dry, Fan

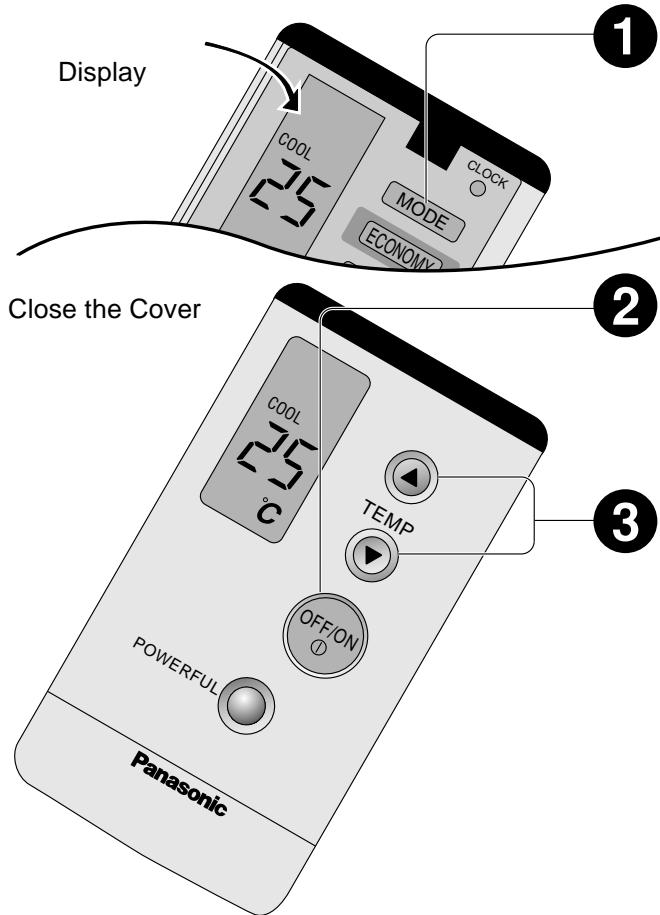

1 Press to select the desired operation mode
When pressed, the display changes in this order.



Close the Cover

2 Press to start the operation
POWER indicator LED (Green) on indoor unit will light up. Press once more to stop operation.

3 Press to select room temperature

• **AUTO** Automatic Operation

Display



Operation with 2°C higher than standard temperature.



Operation with standard temperature.



Operation with 2°C lower than standard temperature.

• **COOL** Cooling, **DRY** Soft Dry operation



Press to increase temperature by 1°C.



Press to decrease temperature by 1°C.

– The temperature can be set between 16°C and 30°C.

– Recommended temperature

For Cooling: 26°C - 28°C.

For Soft Dry: 1°C - 2°C lower than room temperature.



Operation	Standard temperature
COOLING	25°C
SOFT DRY	22°C

■ Operation details

COOL Cooling Operation

- To set room temperature to your preference of cooling comfort.

AUTO – Automatic Operation

- Once the Automatic Operation is selected, the indoor temperature sensor operates automatically to select the desired operation mode with Cooling or Soft Dry.
- After the operation mode have been selected, the mode does not change.
- Temperature is not displayed on remote control during Auto mode operation

DRY – Soft Dry Operation

- A very gentle Cooling Operation. Consisting primarily of dehumidifying. It does not lower the room temperature.
- During Soft Dry operation, the indoor fan operates at Low fan speed.

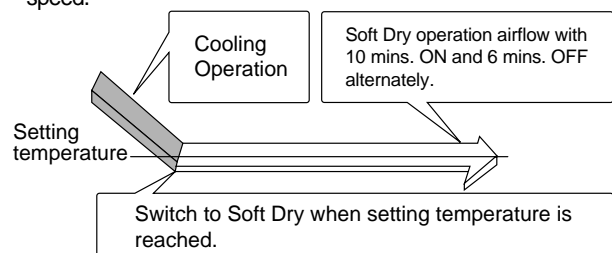

● Adjusting Airflow Direction And Fan Speed

Press to select Fan speed

- The display changes in this order

AUTO FAN → → → → →

Automatic Low Medium High

Selecting Vertical Airflow Direction
Press AUTO,

- The louver swing up and down automatically.
- To stop this operation, press **MANUAL** button.

Press MANUAL

- Manual selection of Vertical Airflow Direction Louver.
- The display changes in this order.

Horizontal Airflow Direction

- Adjust it manually.

■ Operation details

FAN – Air Circulation Operation

- When the room temperature reaches the setting temperature, operation commences at Low airflow volume. It stops when the room temperature drops to 2°C below the setting temperature. (It is useful when using a heater).

Automatic Airflow Volume

- The speed of the Indoor fan is adjusted automatically according to the operation. The Indoor fan stops occasionally during cooling operation.

Louver adjustment range

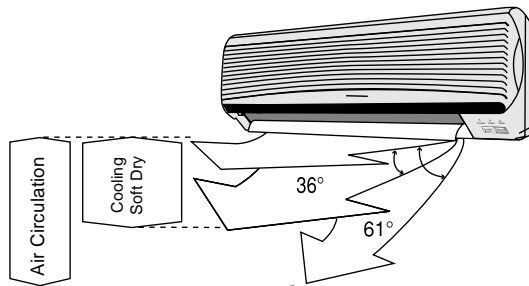

※ Five stages of adjustments can be made in this range.

SETTING THE TIMER

Ensure that the current time is correct before setting the timer. The timer cannot be set if the time display is flashing.

1 Press ON-TIMER
Flashes →

Set the ON-TIMER to 7:00AM

2 Press to set the time
 Increase by 10 minutes
 Decrease by 10 minutes
 ※ Press continuously for quick setting.

3 Press SET
Lights up →

※ The timer indicator (orange) on the indoor unit will light up.

4 To set the OFF-TIMER
Press the OFF-TIMER then follow steps 2 and 3 as above.

■ **Timer Cancellation Button**
(To cancel the Timer)
Press the ON-TIMER or OFF-TIMER then press CANCEL.
※ The timer indicator on the indoor unit will go off.

■ To change the setting time, follow the above steps.

Timer details

- When the ON-Timer is set, operation will start before the actual set time. This is to allow the room temperature to reach the setting temperature by the setting time (maximum of 15 minutes in advance).
- Once the ON-Timer is set, operation will start at the setting time everyday.

● Recommended Setting of Timer

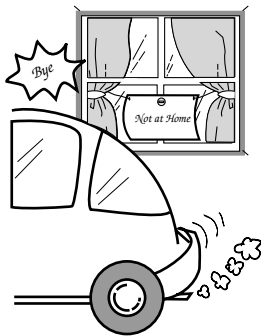
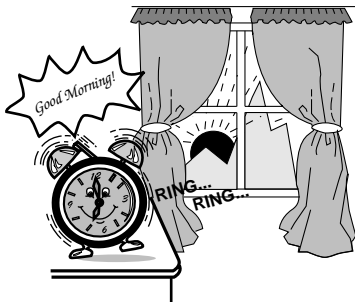

■ When you sleep

- Set the time at which you will go to sleep with the OFF-TIMER. This prevent wastage of electricity.

■ When you wake up

- Set the time at which you will wake up with the ON-TIMER. You can start the new day at a comfortable temperature.

Note:

(The above is an example of how you can used the OFF-TIMER and ON-TIMER mode. However it is recommended to use the sleep mode function for sleeping)

■ When going out

- Set the time at which you will go out with the OFF-TIMER. Set the time at which you will come back with the ON-TIMER.
- This will prevent the air conditioner from being left on while you are out, and the temperature will be pleasant when you return.

■ When you return

- Set the time at which you will return with the ON-TIMER.
- This will make the temperature pleasant when you return, and it will prevent the air conditioner from being left on.

Timer details

- The current time is not displayed when the timers are set.
- When both timers are used together, the TIMER LED on the indoor unit remains lit even if the operation is stopped by the OFF-TIMER.

CONVENIENCE OPERATION

● Sleep Mode

This is to obtain a comfortable room temperature while sleeping.



- To set the sleep mode, press **SLEEP**.
 ※ The sleep indicator on the indoor unit will light up.
- To cancel the sleep mode, press once more.

■ Operation details

- When the room temperature reaches the setting temperature, the airflow volume will automatically change to low.
- Sleep Mode Operation time is 8 hours.
- When used together with the timer, the timer has priority.
- Cooling or Soft Dry Operation for sleep mode movement will start to avoid overcooling.

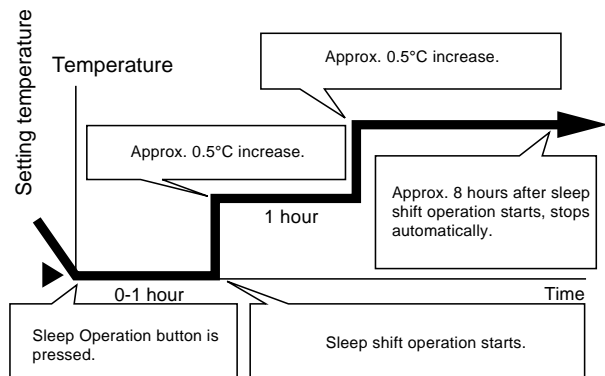

● Economy or Powerful Mode

Economy and Powerful operation cannot be selected simultaneously.

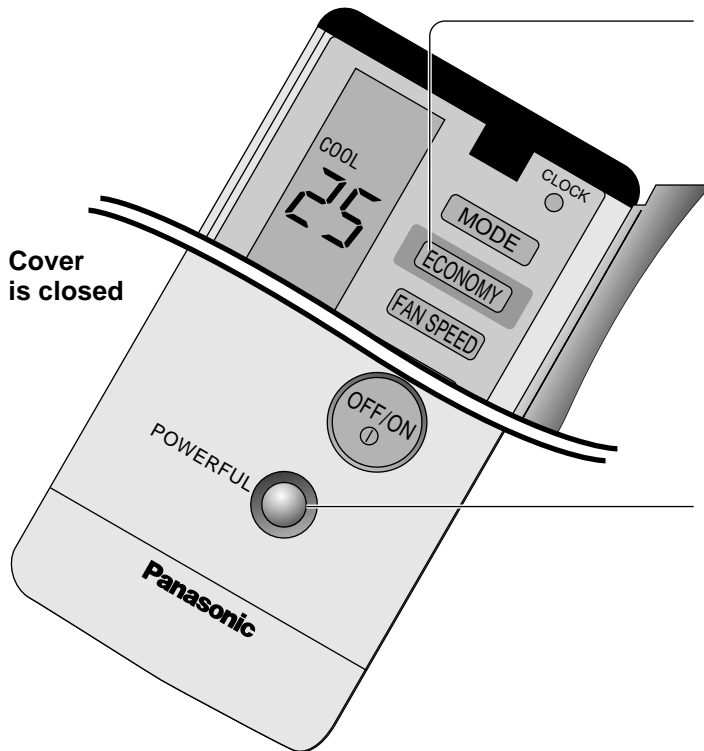

Economy Mode

To save electrical power consumption. However, please use this mode when the room have reached your desired temperature.

- Press ECONOMY
- ✗ Economy indicator (Green) on indoor unit lights up.
- Press once more to cancel this operation.

Powerful Mode

To obtain the setting temperature quickly.

- Press POWERFUL
- ✗ Powerful indicator (Orange) on indoor unit lights up.
- ✗ Powerful mode will operate for 15 minutes only.
- To cancel this operation, press once more.

■ Operation details

	Economy operation		Powerful operation	
	Temperature	Airflow volume	Temperature	Airflow volume
Cooling/Soft Dry	0.5°C higher than set temp.	Low (on and off)	3°C lower than set temp.	Super High

- ✗ • The changes of the temperature and airflow volume are automatic.
- The remote control display remain unchanged.
- If sleep button or operation mode button is pressed, economy or powerful operation is cancelled.
- During **[FAN]**-Air circulation operation, the powerful and economy operation are not available.
- During Economy mode, indoor fan operates on and off at Low speed.

CARE AND MAINTENANCE

● Cleaning the Indoor Unit and Remote Control

- Wipe gently with a soft, dry cloth.
- Do not clean with water hotter than 40°C or with polishing fluids.
- The front panel can be removed and cleaned with water.

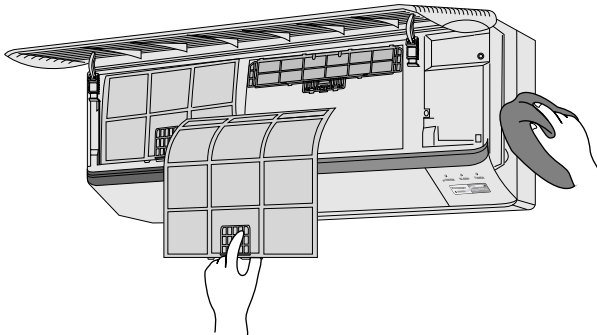

Caution

Switch OFF and unplug the power cord before cleaning the air conditioner.

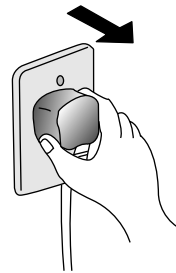

● Cleaning the Air Filter

(Recommendation:- If the unit is operated in a dusty environment, clean the filters every two weeks, continuous use of this dirty filters will reduce cooling efficiency)

- 1 Open the front grille and remove the two air filters. Hold the tab, lift up slightly then pull down.

- 2 Remove dirt using a vacuum cleaner.

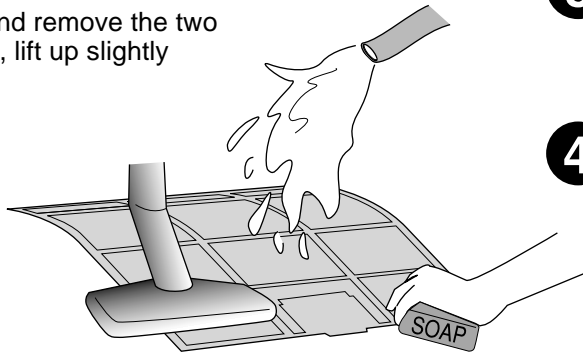

- 3 Wash back of the air filter with water.

- 4 If badly soiled, wash it with soap or a mild household detergent.

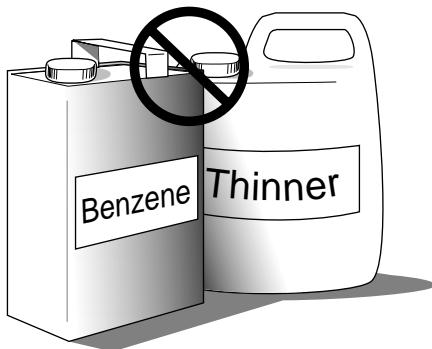

- 5 Let it dry and reinstall it. Be sure the "FRONT" mark is facing you.

※ **Damaged air filter.**
Consult the nearest authorized dealer.
Part No.: CWD00240.

- Do not clean using benzene, thinner, scouring powder or cloths soaked in caustic chemicals.

● Cleaning the Front Panel

(Must be removed before washing)

⚠ Caution

- Stand on a level surface when removing the front panel.
- Do not touch the metal parts in the indoor unit after removing the front panel.
- Do not leave water on the panel after cleaning. Dry thoroughly to prevent electric shock.

■ Removing the front panel

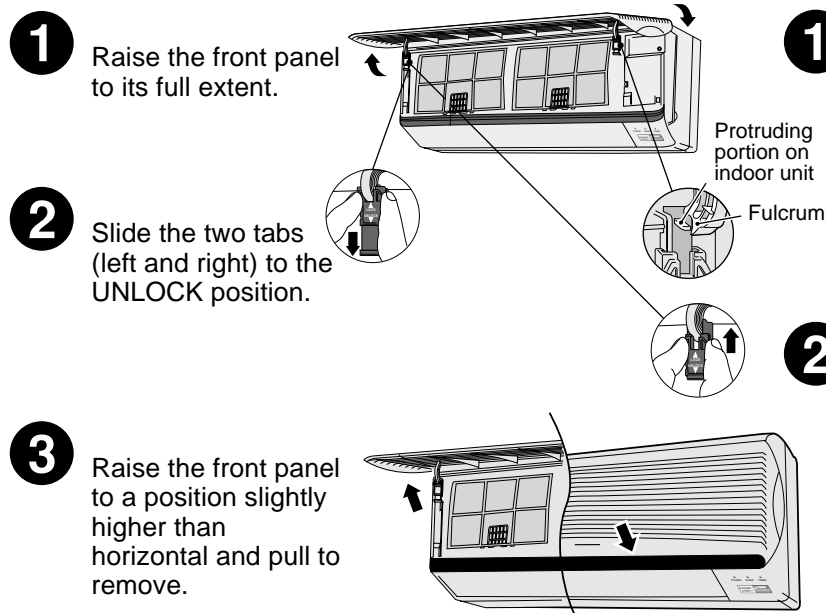

■ Fixing the front panel

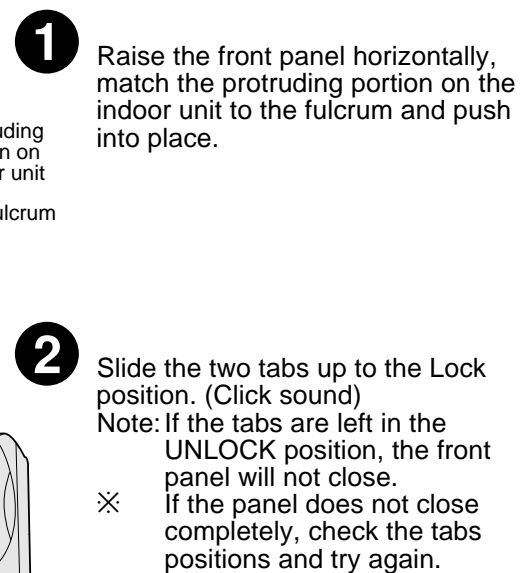

■ Cleaning the front panel

- Gently wash with water and a sponge.
(Do not use a scrubbing brush or other hard cleaning aids).
- Do not press the front panel too hard when washing.
(Excess pressure may damage the panel).
- When cleaning with kitchen cleaning fluids (neutral detergents), rinse thoroughly.
(Do not use non neutral detergents)
- Do not dry the front panel in direct sunlight.
(Exposure to direct sunlight may discolor or deform the panel).

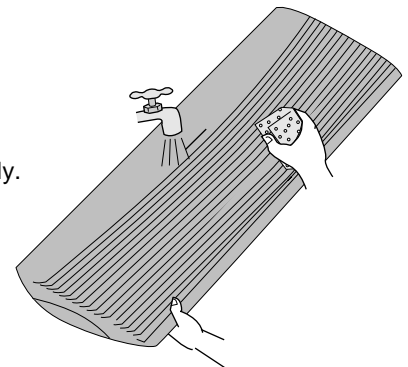

● Replacing the Air Purifying Filters

(Once every 3 month)

- Do not reuse dirty filters. Consult the nearest authorized dealer. (Air Purifying filter No. CZ-SFD50N)
- These filters function effectively for not more than three months.
- If the air conditioner operates with dirty filters:-
 - Air is not purified
 - Cooling capacity decreases
 - Foul odours are emitted
- Note:
Catechin is natural brown element. The filter is coated with catechin in order to prevent the growth of bacteria and viruses.

■ Removing the air purifying filters

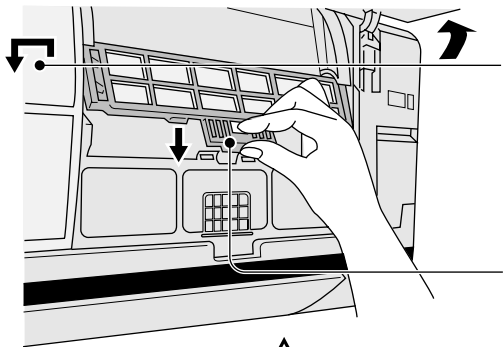

- 1** Raise the front panel to its full extent.
- 2** Remove the air filters (left and right).
 - Lift up slightly then pull down
- 3** Hold the tabs of the air purifying filters and pull.



Caution - Be careful not to hurt your hands on metal parts.

■ Reinstalling the air purifying filters

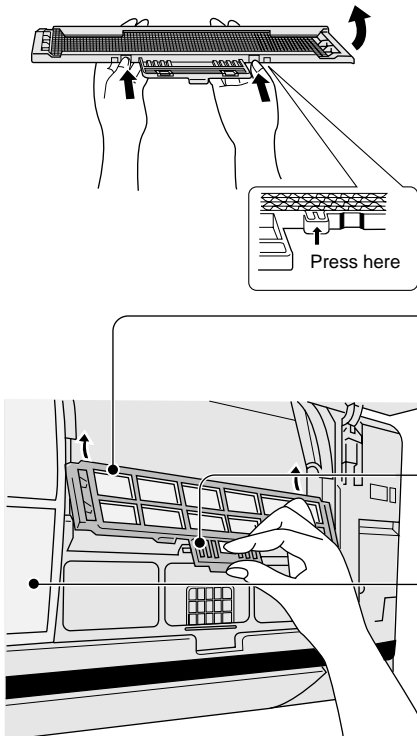

- 1** Open the filter frame to insert the new filters.
 - Deodorizing Filter (Black in colour)
 - Catechin Air Purifying Filter (Brown in colour)
- 2** Insert the new air purifying filter.
(Be sure the "FRONT" mark is facing you)
- 3** Push until you hear a click.
- 4** Reinsert the air filters.
- 5** Close the front panel .

● Pre-season Inspection

- **Is the discharge air cold?**
Operation is normal if 15 minutes after the start of operation, the difference between the air intake and outlet vents temperatures is 8°C or above for cooling.

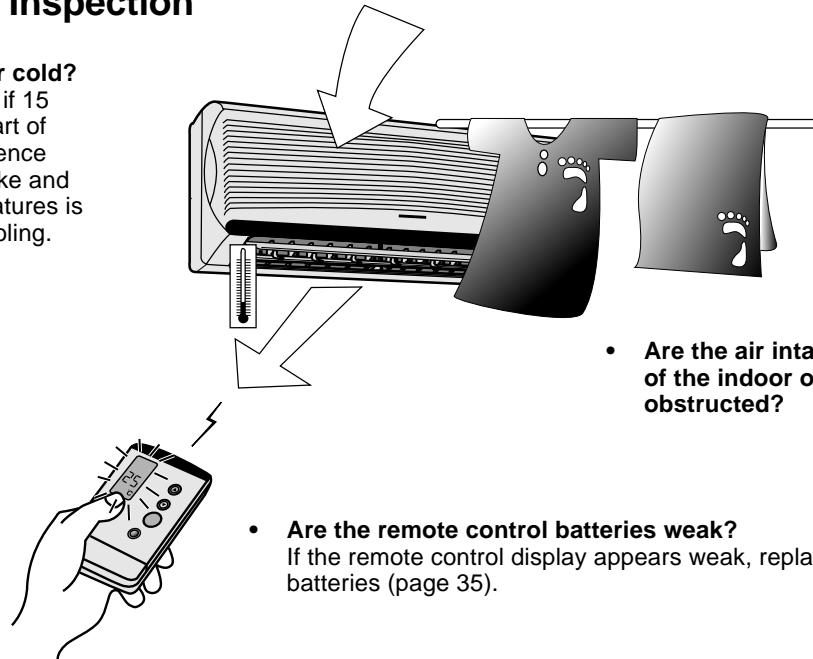

- **Are the air intake or outlet vents of the indoor or outdoor units obstructed?**

- **Are the remote control batteries weak?**
If the remote control display appears weak, replace the batteries (page 35).

● When the Air Conditioner is Not Used For an Extended Period of Time

- 1** To dry the internal parts of the indoor unit, operate the unit for 2 - 3 hours using **FAN** operation.

- 2** Turn off the power switch and remove the power supply plug.
Note: If the unit is not switched off by the remote control, it will start operating when you plug in (because a Auto Restart Control is provided).

- 3** Remove the remote control batteries.

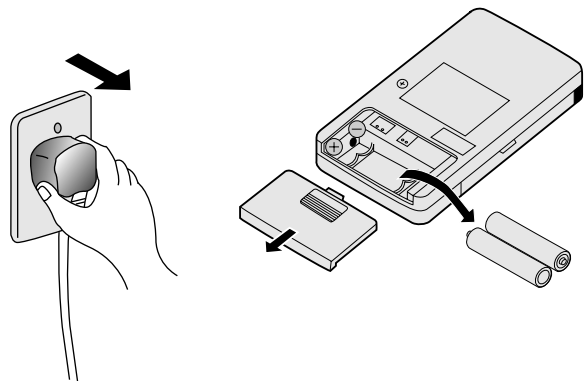

● Recommended Inspection

- The unit will become dirty after use over several seasons, reducing performance. Depending on the operation condition, a dirty unit may produce foul odours and dust may pollute the dehumidifying drainage. Seasonal inspection is recommended, in addition to regular cleaning. Consult an authorized dealer.

TROUBLESHOOTING

● Normal Operation

Q - Is it okay?

A - This is the answer.

Q - Air conditioner has been restarted, but does not operate for 3 minutes.

A - This is to protect the air conditioner. Wait until the air conditioner begins operating.

Q - A sound like water flowing can be heard.

A - This is the sound of refrigerant flowing inside the air conditioner unit.

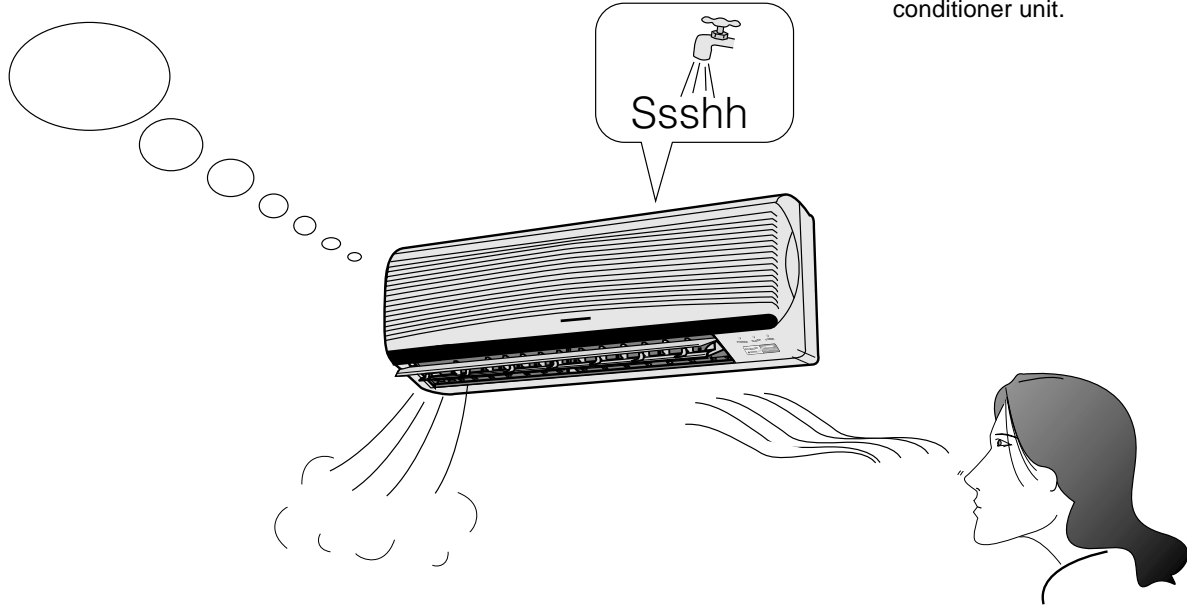

Q - It seems that fog is coming out from the air conditioner.

A - Condensation occurs when the airflow from the air conditioner cools the room air.

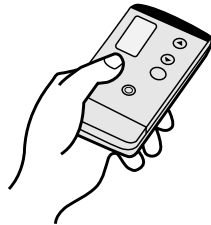

Q - The room has a peculiar odour.

A - This may be a damp smell emitted by the walls, carpet, furniture or clothing in the room.

DRY

Q - During soft dry mode operation the air conditioner stops.

A - Soft Dry Mode operation is a very gentle cooling operation consisting primarily of dehumidifying. The air conditioner may stop for approximately 6 minutes in order to prevent overcooling. If the room temperature rises again, the operation will recommence.

AUTO FAN

Q - During Automatic Vertical Airflow setting, indoor fan stops occasionally.

A - This is to remove the smell emitted by the surroundings.

● Abnormal Operation

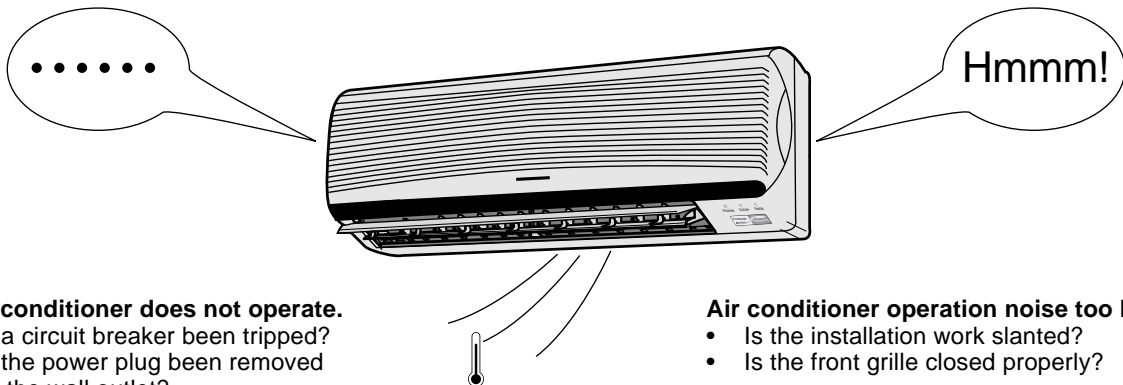

The air conditioner does not operate.

- Has a circuit breaker been tripped?
- Has the power plug been removed from the wall outlet?
- Is the timer being used correctly?

Air conditioner operation noise too loud.

- Is the installation work slanted?
- Is the front grille closed properly?

The air conditioner does not cool effectively.

- Has the temperature been set incorrectly?
- Are the filters dirty?
- Are the intake or outlet vents of the outdoor unit obstructed?
- Are all windows and doors closed?

● Call the Dealer Immediately

If the following conditions occur, immediately turn off the main power supply and unplug.

- Abnormal noise is heard during operation.

- Switches or buttons do not operate properly.

- Water or foreign material gets into the remote control by mistake.

- The circuit breaker switches off frequently.



- Water leaks from the indoor unit.

- Power supply cord and plug become unusually warm.

HELPFUL INFORMATION

Auto Operation Button

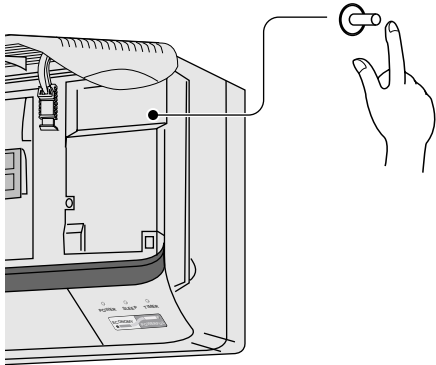

- Automatic Operation
 - If the remote control fails to function or misplaced, press Auto Operation button for Automatic operation.
 - The Automatic operation will be activated immediately once the Auto operation button is pressed. However, temperature cannot be adjusted in this operation.
 - The power LED on the indoor unit blinks until the operation mode is selected automatically.
 - To cancel this operation, press once more.

- Remote Control Signal Receiving Sound
 - To switch off the beep (Signal Receiving Sound), press this Auto Operation button for 10 seconds continuously or longer. "Beep", "beep" sound will be heard at the tenth seconds.
 Note: "Beep" sound will be heard at the fifth seconds; However please press continuously until you heard "beep", "beep" sound.
 - Repeat this, if you want to switch on the Signal Receiving Sound.

- ※ Note: If you press this button continuously for 5 to 10 seconds, Test Run operation will be performed. A "beep" sound will be heard at the fifth seconds, to identify the starting of Test Run operation.
(This is for Servicing purpose only.)

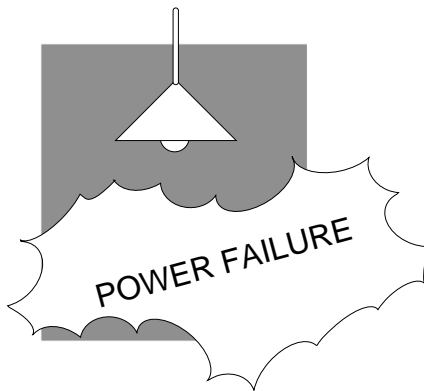

Auto Restart Control

- If power is resumed after a power failure, the operation will restart automatically after 3 - 5 1/2 minutes.
- Operation will be automatically restart under the previous operation mode and airflow direction when power is resumed as the operation is not stopped by remote control.

Timer Setting

- When power failure occurs, the timer setting is cancelled. Once power is resumed, reset the timer.

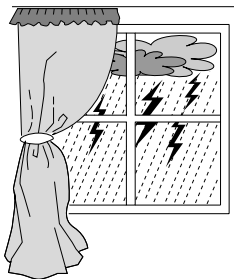

Thunder and Lightning

- This air conditioner is equipped with a built-in surge protective device. However, in order to further protect your air conditioner from being damaged by abnormally strong lightning activity, you may switch off the main power supply and unplug from power socket.

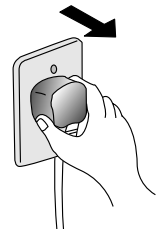

ENERGY SAVING AND OPERATION HINTS

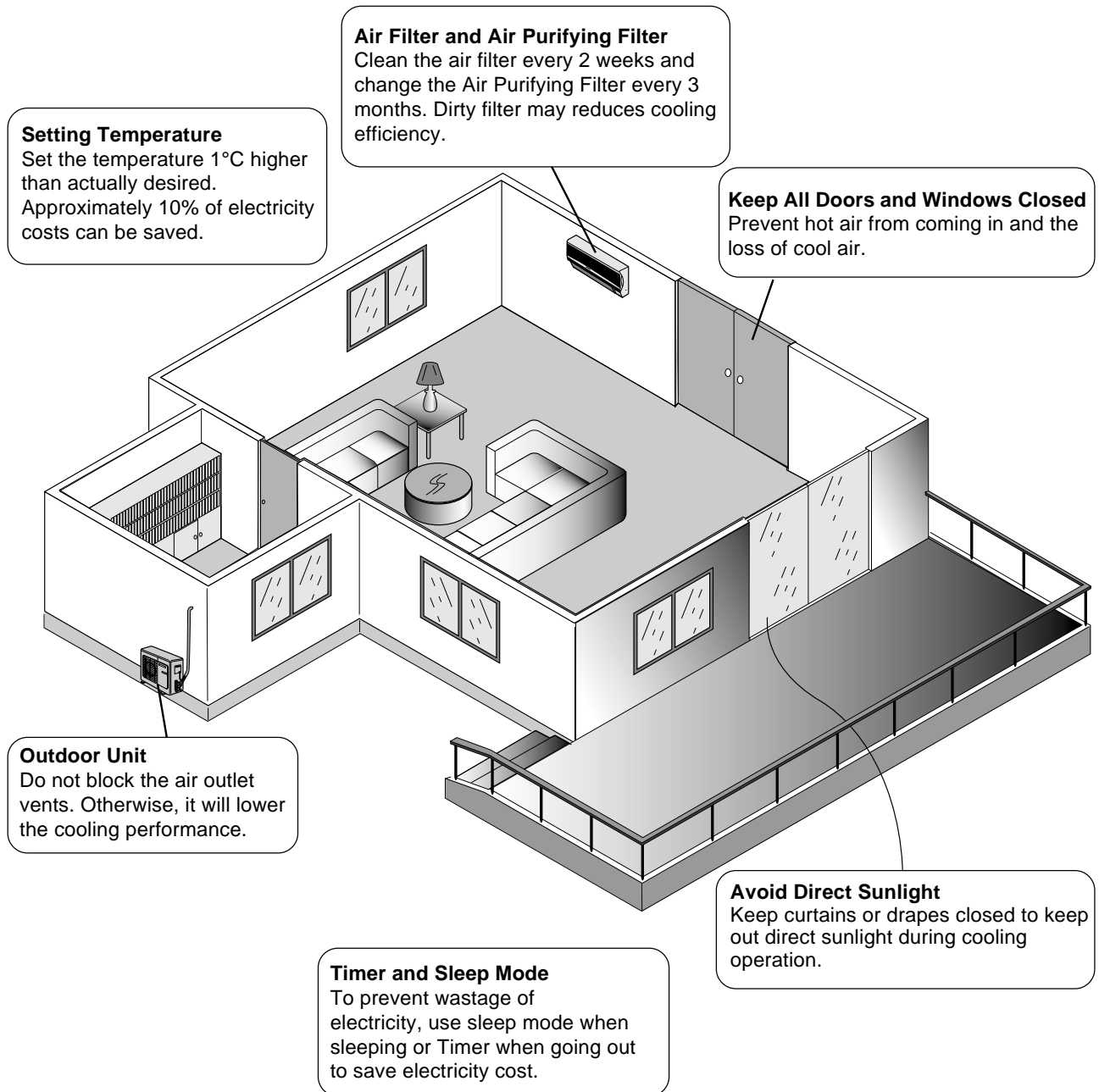

 **Warning**

- 1) This appliance must be earthed.
- 2) If the supply cord is damaged or need to be replaced, it must be replaced by the manufacturer or its service agent or a similarly qualified person in order to avoid a hazard.
- 3) Remove power plug or disconnect from the mains before servicing this appliance.
- 4) Do not repair by yourself.
In case of malfunction of this appliance, do not repair by yourself.
Contact to the sales dealer or service dealer for a repair.
- 5) Do not use in an explosive atmosphere.

Do not use this appliance in a potentially explosive atmosphere.
- 6) Turn off the power (Isolation from main power supply).
Pull off the power plug from the receptacle, or switch off the breaker, or switch off the power disconnecting mean to isolate the equipment from the main power supply in case of an emergency.

 **Caution**

DISCONNECT THE MAINS PLUG FROM THE SUPPLY SOCKET WHEN NOT IN USE, WHERE SUPPLY CONNECTION IS VIA MAINS PLUG.

Airborne noise.

A-weighted sound pressure level of this appliance is less than 70dB (A) under the JIS C 9612 test conditions.

Maximum cooling operation
1 m from the unit

IMPORTANT

The wires in this mains lead are coloured in accordance with the following code:

Green and Yellow	:	Earth
Blue	:	Neutral
Brown	:	Live

“As the colours of the wires in the mains lead of this appliance may not correspond with the coloured markings identifying the terminals in your plug, proceed as follows:

The wire which is coloured green and yellow must be connected to the terminal in the plug which is marked by the letter E or by safety earth symbol \oplus or coloured green or green and yellow.

The wire which is coloured blue must be connected to the terminal which is marked with letter N or coloured black.

The wire which is coloured brown must be connected to the terminal which is marked with letter L or coloured red.”

10 Installation And Servicing Air Conditioner Using R410A

10.1. OUTLINE

10.1.1. About R410A Refrigerant

1. Converting air conditioners to R410A

Since it was declared in 1974 that chlorofluorocarbons (CFC), hydro chlorofluorocarbons (HCFC) and other substances pose a destructive danger to the ozone layer in the earth's upper stratosphere (20 to 40 km above the earth), measures have been taken around the world to prevent this destruction.

The R22 refrigerant which has conventionally been used in ACs is an HCFC refrigerant and, therefore, possesses this ozone-destroying potential. International regulations (the Montreal Protocol Ozone-Damaging Substances) and the domestic laws of various countries call for the early substitution of R22 by a refrigerant which will not harm the ozone layer.

- In ACs, the HFC refrigerant which has become the mainstream alternative called R410A. Compared with R22, the pressure of R410A is approximately 1.6 times as high at the same refrigerant temperature, but the energy efficiency is about the same. Consisting of hydrogen (H), fluorine (F) and carbon (C), R410A is an HFC refrigerant. Another typical HFC refrigerant is R407C. While the energy efficiency of R407C is somewhat inferior to that of R410A, it offers the advantage of having pressure characteristics which are about the same as those of R22, and is used mainly in packaged ACs.

2. The characteristics of HFC (R410A) refrigerants

a. Chemical characteristics

The chemical characteristics of R410A are similar to those of R22 in that both are chemically stable, non-flammable refrigerants with low toxicity.

However, just like R22, the specific gravity of R410A gas is heavier than that of air. Because of this, it can cause an oxygen deficiency if it leaks into a closed room since it collects in the lower area of the room. It also generates toxic gas when it is directly exposed to a flame, so it must be used in a well ventilated environment where it will not collect.

Table 1 Physical comparison of R410A and R22

	R410A	R22
Composition (wt%)	R32/R125 (50/50)	R22 (100)
Boiling point (°C)	-51.4	-40.8
Vaporizing pressure (25°C)	1.56 Mpa (15.9 kgf/cm ²)	0.94 Mpa (9.6 kgf/cm ²)
Saturated vapor density	64.0 kg/m ³	44.4 kg/m ³
Flammability	Non-flammable	Non-flammable
Ozone-destroying point (ODP)	0	0.005
Global-warming point (GWP)	1730	1700

b. Compositional change (pseudo-azeotropic characteristics)

R410A is a pseudo-azeotropic mixture comprising the two components R32 and R125. Multi-component refrigerants with these chemical characteristics exhibit little compositional change even from phase changes due to vaporization (or condensation), which means that there is little change in the circulating refrigerant composition even when the refrigerant leaks from the gaseous section of the piping.

Accordingly, R410A can be handled in almost the same manner as the single-component refrigerant R22. However, when charging, because there is a slight change in composition between the gas phase and the liquid phase inside a cylinder or other container, charging should basically begin with the liquid side.

c. Pressure characteristics

As seen in Table 2, the gas pressure of R410A is approximately 1.6 times as high as that of R22 at the same refrigerant temperature, which means that special R410A tools and materials with high-pressure specifications must be used for all refrigerant piping work and servicing.

Table 2 Comparison of R410A and R22 saturated vapor density

Refrigerant Temperature (°C)	Unit: MPa	
	R410A	R22
-20	0.30	0.14
0	0.70	0.40
20	1.35	0.81
40	2.32	1.43
60	3.73	2.33
65	4.15	2.60

d. R410A refrigerating machine oil

Conventionally, mineral oil or a synthetic oil such as alkylbenzene has been used for R22 refrigerating machine oil. Because of the poor compatibility between R410A and conventional oils like mineral oil, however, there is a tendency for the refrigerating machine oil to collect in the refrigerating cycle. For this reason, polyester and other synthetic oils which have a high compatibility with R410A are used as refrigerating machine oil.

Because of the high hygroscopic property of synthetic oil, more care must be taken in its handling than was necessary with conventional refrigerating machine oils. Also, these synthetic oils will degrade if mixed with mineral oil or alkylbenzene, causing clogging in capillary tubes or compressor malfunction. Do not mix them under any circumstances.

10.1.2. Safety Measure When Installing / Receiving Refrigerant Piping

Cause the gas pressure of R410A is approximately 1.6 times as high as that of R22, a mistake in installation or servicing could result in a major accident. It is essential that you use R410a tools and materials, and that you observe the following precautions to ensure safety.

1. Do not use any refrigerant other than R410A in ACs that have been used with R410A.
2. If any refrigerant gas leaks while you are working, ventilate the room. Toxic gas may be generated if refrigerant gas is exposed to a direct flame.
3. When installing or transferring an AC, do not allow any air or substance other than R410A to mix into the refrigeration cycle. If it does, the pressure in the refrigeration cycle can become abnormally high, possibly causing an explosion and/or injury.
4. After finishing the installation, check to make sure there is no refrigerant gas leaking.
5. When installing or transferring an AC, follow the instructions in the installation instructions carefully. Incorrect installation can result in an abnormal refrigeration cycle or water leakage, electric shock, fire, etc.
6. Do not perform any alterations on the AC unit under any circumstances. Have all repair work done by a specialist. Incorrect repairs can result in an water leakage, electric shock, fire, etc.

10.2. TOOL FOR INSTALLING / SERVICING REFRIGERANT PIPING

10.2.1. Necessary Tools

In order to prevent an R410A AC from mistakenly being charged with any other refrigerant, the diameter of the 3-way valve service port on the outdoor unit has been changed. Also, to increase its ability to withstand pressure, the opposing dimensions have been changed for the refrigerant pipe flaring size and flare nut. Accordingly, when installing or servicing refrigerant piping, you must have both the R410A and ordinary tools listed below.

Table 3 Tools for installation, transferring or replacement

Type of work	Ordinary tools	R410A tools
Flaring	Flaring tool (clutch type), pipe cutter, reamer	Copper pipe gauge for clearance Adjustment, flaring tool (clutch type)*1)
Bending, connecting pipes	Torque wrench (nominal diameter 1/4, 3/8, 1/2) Fixed spanner (opposing sides 12 mm, 17 mm, 19 mm) Adjustable wrench, Spring bender	
Air purging	Vacuum pump Hexagonal wrench (opposing sides 4 mm)	Manifold gauge, charging hose, vacuum pump adaptor
Gas leak inspection	Gas leak inspection fluid or soapy water	Electric gas leak detector for HFC refrigerant*2)

*1) You can use the conventional (R22) flaring tool. If you need to buy a new tool, buy the R410A type.

*2) Use when it is necessary to detect small gas leaks.

For other installation work, you should have the usual tools, such as screwdrivers (+,-), a metal-cutting saw, an electrical drill, a hole core drill (65 or 70 dia.), a tape measure, a level, a thermometer, a clamp meter, an insulation tester, a voltmeter, etc.

Table 4 Tools for serving

Type of work	Ordinary tools	R410A tools
Refrigerant charging		Electronic scale for refrigerant charging Refrigerant cylinder Charging orifice and packing for refrigerant cylinder
Brazing (Replacing refrigerating cycle part*1)	Nitrogen blow set (be sure to use nitrogen blowing for all brazing), and brazing), and brazing machine	

*1) Always replace the dryer of the outdoor unit at the same time. The replacement dryer is wrapped in a vacuum pack. Replace it last among the refrigerating cycle parts. Start brazing as soon as you have opened the vacuum pack, and begin the vacuuming operation within 2 hours.

10.2.2. R410A Tools

1. Cooper tube gauge for clearance adjustment
(used when flaring with the conventional flaring tool (clutch type))

- This gauge makes it easy to set the clearance for the copper tube to 1.0-1.5 mm from the clamp bar of the flaring tool.

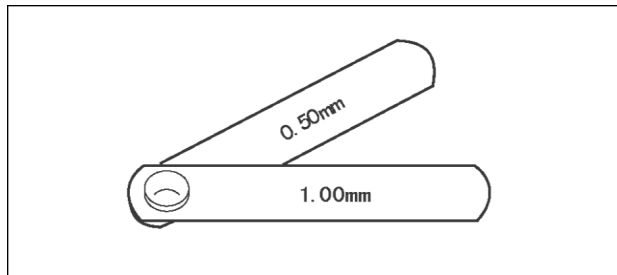

Fig. 1 Copper tube gauge for clearance adjustment

2. Flaring tool (clutch type)

- In the R410A flaring tool, the receiving hole for the clamp bar is enlarged so the clearance from the clamp bar can be set to 0-0.5 mm, and the spring inside the tool is strengthened to increase the strength of the pipe-expanding torque. This flaring tools can also be used with R22 piping, so we recommend that you select it if you are buying a new flaring tool.

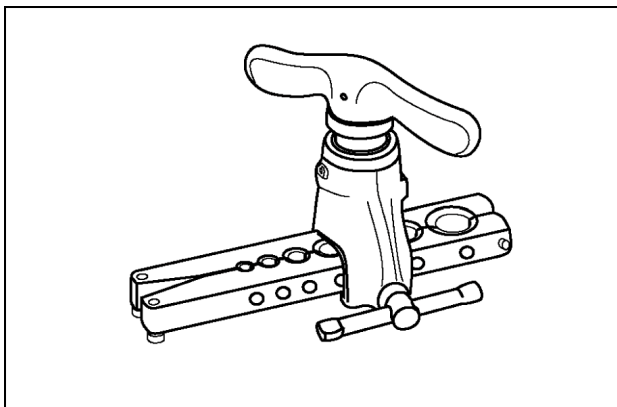

Fig. 2 Flaring tool (clutch type)

3. Torque wrenches

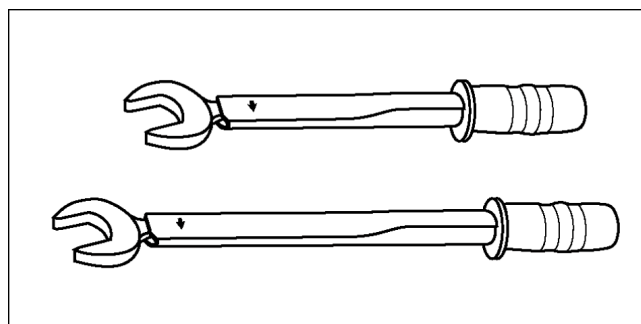

Fig. 3 Torque wrenches

Table 5

	Conventional wrenches	R410A wrenches
For 1/4 (opposite side x torque)	17 mm x 18 N.m (180 kgf.cm)	17 mm x 18 N.m (180 kgf.cm)
For 3/3 (opposite side x torque)	22 mm x 42 N.m (180 kgf.cm)	22 mm x 42 N.m (180 kgf.cm)
For 1/2 (opposite side x torque)	24 mm x 55 N.m (180 kgf.cm)	26 mm x 55 N.m (180 kgf.cm)

4. Manifold gauge

- Because the pressure is higher for the R410A type, the conventional type cannot be used.

Table 6 Difference between R410A and conventional high / low-pressure gauges

	Conventional wrenches	R410A wrenches
High-pressure gauge (red)	-76 cmHg - 35 kgf/cm ³	-0.1 - 5.3 Mpa -76 cmHg - 53 kgf/cm ³
High-pressure gauge (blue)	-76 cmHg - 17 kgf/cm ³	-0.1 - 3.8 Mpa -76 cmHg - 38 kgf/cm ³

- The shape of the manifold ports has been changed to prevent the possibility of mistakenly charging with another type of refrigerant.

Table 7 Difference between R410A and conventional manifold port size

	Conventional gauges	R410A gauges
Port size	7/6 UNF 20 threads	1/2 UNF 20 threads

5. Charging hose

- The pressure resistance of the charging hose has been raised to match the higher pressure of R410A. The hose material has also been changed to suit HFC use, and the size of the fitting has been changed to match the manifold ports.

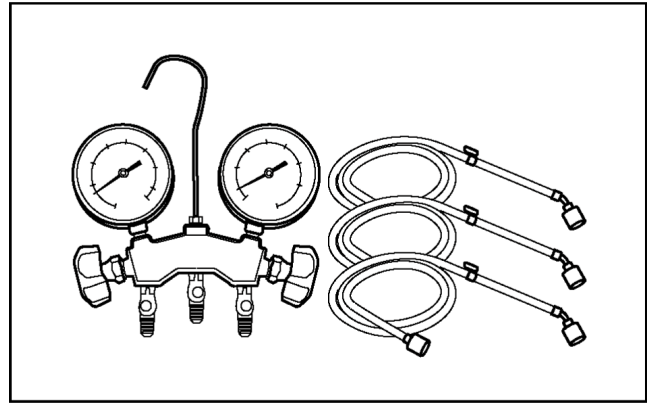

Fig. 4 Manifold gauge charging hose

Table 8 Difference between R410A and conventional charging hoses

		Conventional hoses	R410A hoses
Pressure resistance	Working pressure	3.4 MPa (35 kgf/cm ³)	5.1 MPa (52 kgf/cm ³)
	Bursting pressure	17.2 MPa (175 kgf/cm ³)	27.4 MPa (280 kgf/cm ³)
Material		NBR rubber	HNBR rubber Nylon coating inside

6. Vacuum pump adaptor

- When using a vacuum pump for R410A, it is necessary to install an electromagnetic valve to prevent the vacuum pump oil from flowing back into the charging hose. The vacuum pump adaptor is installed for that purpose. If the vacuum pump oil (mineral oil) becomes mixed with R410A, it will damage the unit.

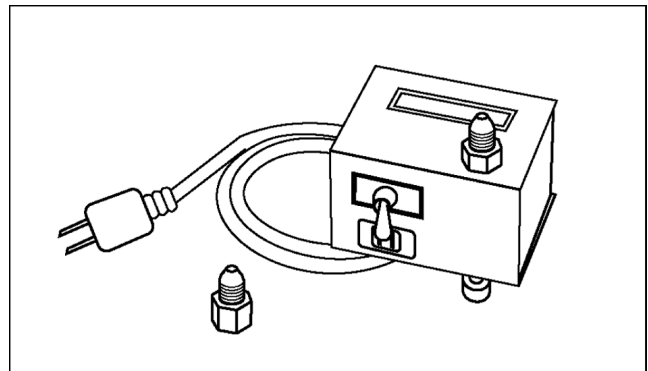

Fig. 5 Vacuum pump adaptor

7. Electric gas leak detector for HFC refrigerant

- The leak detector and halide torch that were used with CFC and HCFC cannot be used with R410A (because there is no chlorine in the refrigerant).
- The present R134a leak detector can be used, but the detection sensitivity will be lower (setting the sensitivity for R134a at 1, the level for R410A will drop to 0.6).
- For detecting small amounts of gas leakage, use the electric gas leak detector for HFC refrigerant. (Detection sensitivity with R410A is about 23 g/year).

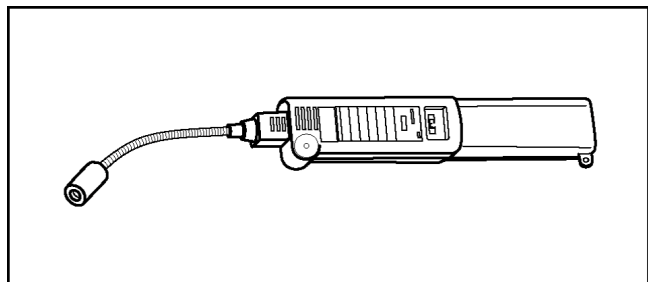

Fig. 6 Electric gas leak detector for HFC refrigerant

8. Electronic scale for refrigerant charging

- Because of the high pressure and fast vaporizing speed of R410A, the refrigerant cannot be held in a liquid phase inside the charging cylinder when charging is done using the charging cylinder method, causing bubbles to form in the measurement scale glass and making it difficult to see the reading. (Naturally, the conventional R22 charging cylinder cannot be used because of the differences in the pressure resistance, scale gradation, connecting port size, etc.)
- The electronic scale has been strengthened by using a structure in which the weight detector for the refrigerant cylinder is held by four supports. It is also equipped with two connection ports, one for R22 (*7/16 UNF, 20 threads) and one for R410A (1/2 UNF, 20 threads), so it can also be used for conventional refrigerant charging.
- There are two types of electronic scales, one for 10-kg cylinders and one for 20-kg cylinders. (The 10-kg cylinder is recommended.)

Refrigerant charging is done manually by opening and closing the valve.

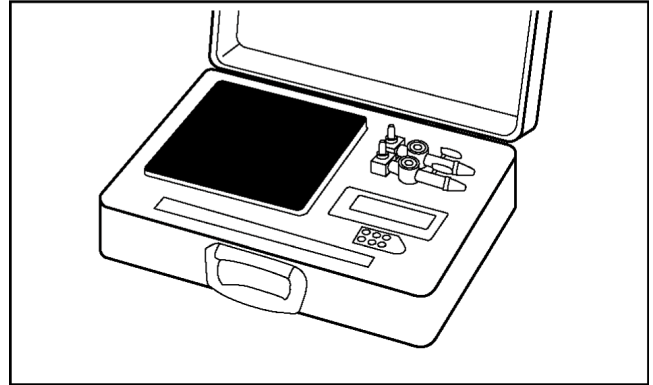

Fig. 7 Electronic scale for refrigerant charging

9. Refrigerant cylinders

- The R410A cylinders are labeled with the refrigerant name, and the coating color of the cylinder protector is pink, which is the color stipulated by ARI of the U.S.
- Cylinder equipped with a siphon tube are available to allow the cylinder to stand upright for liquid refrigerant charging.

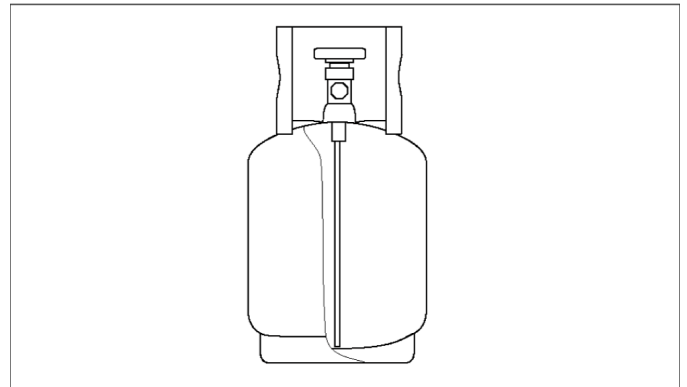

Fig. 8 Refrigerant cylinders

10. Charging orifice and packing for refrigerant cylinders

- The charging orifice must match the size of the charging hose fitting (1/2 UNF, 20 threads).
- The packing must also be made of an HFC-resistant material.

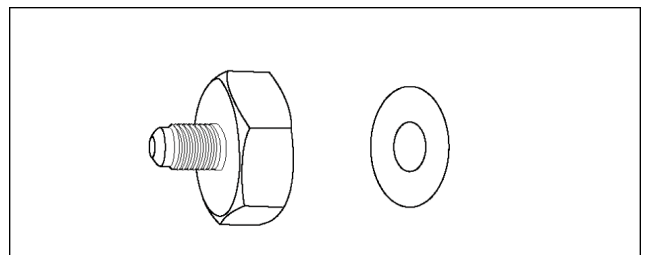

Fig. 9 Charging orifice and packing

10.2.3. R410A Tools Which Are Usable for R22 Models

Table 9 R410A tools which are usable for R22 models

	R410A tools	Usable for R22 models
(1)	Copper tube gauge for clearance adjustment	OK
(2)	Flaring tool (clutch type)	OK
(3)	Manifold gauge	NG
(4)	Charging hose	NG
(5)	Vacuum pump adaptor	OK
(6)	Electric gas leak detector for HFC refrigerant	NG
(7)	Electronic scale for refrigerant charging	OK
(8)	Refrigerant cylinder	NG
(9)	Charging orifice and packing for refrigerant cylinder	NG

10.3. REFRIGERANT PIPING WORK

10.3.1. Piping Materials

It is recommended that you use copper and copper alloy jointless pipes with a maximum oil adherence of 40 mg/10m. Do not use pipes that are crushed, deformed, or discolored (especially the inside surface). If these inferior pipes are used, impurities may clog the expansion valves or capillaries.

Because the pressure of ACs using R410A is higher than those using R22, it is essential that you select materials that are appropriate for these standards.

The thickness of the copper tubing used for R410A is shown in Table 10. Please be aware that tubing with a thickness of only 0.7 mm is also available on the market, but this should never be used.

Table 8 Difference between R410A and conventional charging hoses

Soft pipe		Thickness (mm)	
Nominal diameter	Outside diameter (mm)	R410A	(Reference) R22
1/4	6.35	0.80	0.80
3/8	9.52	0.80	0.80
1/2	12.7	0.80	0.80

10.3.2. Processing and Connecting Piping Materials

When working with refrigerant piping, the following points must be carefully observed: no moisture or dust must be allowed to enter the piping, and there must be no refrigerant leaks.

1. Procedure and precautions for flaring work

a. Cut the pipe

Use a pipe cutter, and cut slowly so the pipe will not be deformed.

b. Remove burrs and clean shavings from the cut surface

If the shape of the pipe end is poor after removing burrs, or if shavings adhere to the flared area, it may lead to refrigerant leaks.

To prevent this, turn the cut surface downward and remove burrs, then clean the surface, carefully.

c. Insert the flare nut (be sure to use the same nut that is used on the AC unit)

d. Flaring

Check the clamp bar and the cleanliness of the copper pipe.

Be sure to use the clamp bar to do the flaring with accuracy. Use either an R410A flaring tool, or a conventional flaring tool. Flaring tools come in different sizes, so be sure to check the size before using. When using a conventional flaring tool, use the copper pipe gauge for clearance adjustment, etc., to ensure the correct A dimension (see Fig. 10)

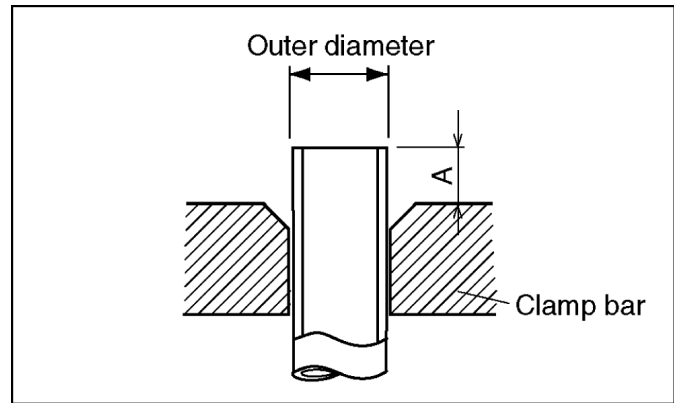

Fig. 10 Flaring dimensions

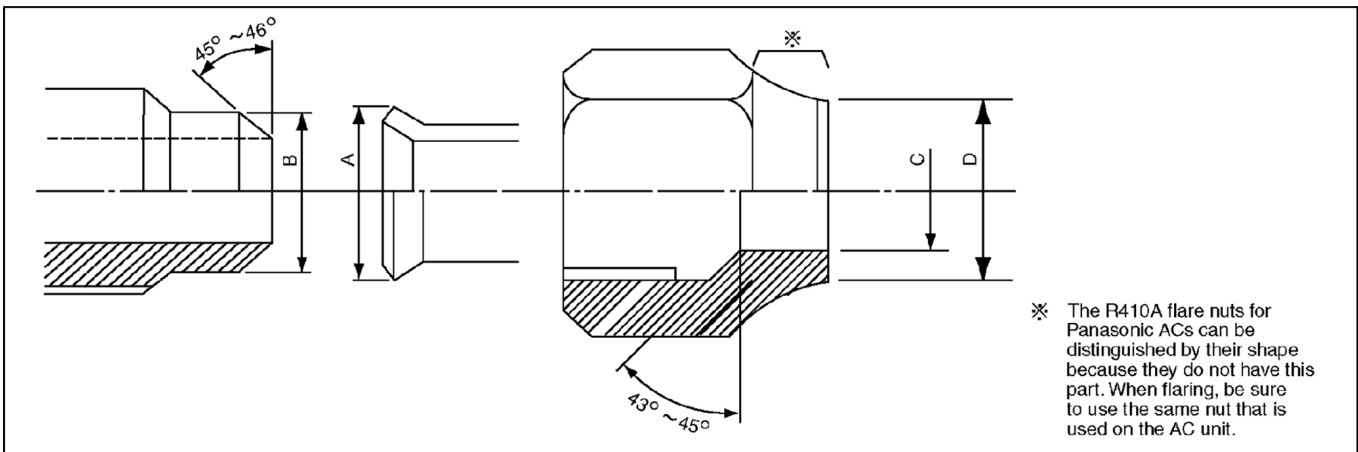

Fig. 11 Relation between the flare nut structure and flaring tool end

Table 11 R410A flaring dimensions

Nominal diameter	Outside diameter (mm)	Wall thickness (mm)	A (mm)		
			R410A flaring tool, clutch type	Conventional flaring tool	
				Clutch type	Wing-nut type
1/4	6.35	0.8	0 - 0.5	1.0 - 1.5	1.5 - 2.0
3/8	9.52	0.8	0 - 0.5	1.0 - 1.5	1.5 - 2.0
1/2	12.70	0.8	0 - 0.5	1.0 - 1.5	2.0 - 2.5

Table 12 R410A flaring dimensions

Nominal diameter	Outside diameter (mm)	Wall thickness (mm)	A (mm)		
			R410A flaring tool, clutch type	Conventional flaring tool	
				Clutch type	Wing-nut type
1/4	6.35	0.8	0 - 0.5	0.5 - 1.0	1.0 - 1.5
3/8	9.52	0.8	0 - 0.5	0.5 - 1.0	1.0 - 1.5
1/2	12.70	0.8	0 - 0.5	0.5 - 1.0	1.5 - 2.0

Table 13 R410A flaring and flare nut dimensions Unit: mm

Nominal diameter	Outside diameter (mm)	Wall thickness (mm)	A +0, -0.4	B dimension	C dimension	D dimension	Flare nut width
1/4	6.35	0.8	9.1	9.2	6.5	13	17
3/8	9.52	0.8	13.2	13.5	9.7	20	22
1/2	12.70	0.8	16.6	16.0	12.9	23	26

Table 14 R410A flaring and flare nut dimensions Unit: mm

Nominal diameter	Outside diameter (mm)	Wall thickness (mm)	A +0, -0.4	B dimension	C dimension	D dimension	Flare nut width
1/4	6.35	0.8	9.0	9.2	6.5	13	17
3/8	9.52	0.8	13.0	13.5	9.7	20	22
1/2	12.70	0.8	16.2	16.0	12.9	20	24

2. Procedure and precautions for flare connection

- a. Check to make sure there are no scratches, dust, etc., on the flare and union.
- b. Align the flared surface with the axial center of the union.
- c. Use a torque wrench, and tighten to the specified torque. The tightening torque for R410A is the same as the conventional torque value for R22. Be careful, because if the torque is too weak, it may lead to a gas leak. If it is too strong, it may split the flare nut or make it impossible to remove the flare nut.

Table 15 R410A tightening torque

Nominal diameter	Outside diameter (mm)	Tightening torque N.m (kgf.cm)	Torque wrench tightening torque N.m (kgf.cm)
1/4	6.35	14 - 18 (140 - 180)	18 (180)
3/8	9.52	33 - 42 (330 - 420)	42 (420)
1/2	12.70	55 (550)	55 (550)

10.3.3. Storing and managing Piping Materials

1. Types of piping and their storage

The following is a general classification of the refrigerant pipe materials used for ACs.

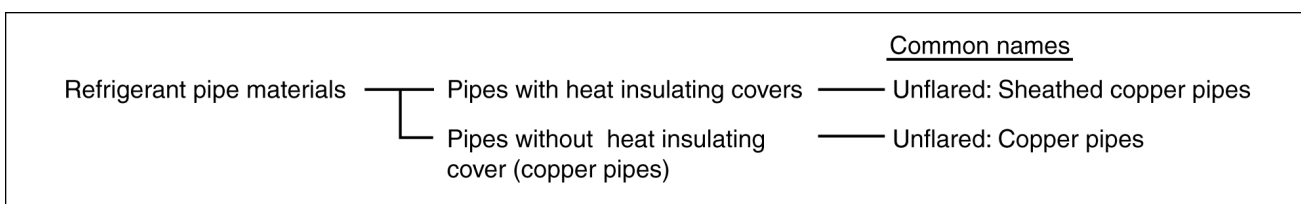

Because the gas pressure of R410A is approximately 1.6 times as high as that of R22, copper pipes with the thickness shown in Table 10, and with minimal impurities must be used. Care must also be taken during storage to ensure that pipes are not crushed, deformed, or scratched, and that no dust, moisture or other substance enters the pipe interior. When storing sheathed copper pipes or plain copper pipes, seal the openings by pinching or taping them securely.

2. Makings and management

a. Sheathed copper pipes and copper-element pipes

When using these pipes, check to make sure that they are the stipulated thickness. For flare nuts, be sure to used the same nut that is used on the AC unit.

b. Copper pipes

Use only copper pipes with the thickness given in table 10, and with minimal impurities. Because the surface of the pipe is exposed, you should take special care, and also take measures such as marking the pipes to make sure they are easily distinguished from other piping materials, to prevent mistaken use.

3. Precautions during refrigerant piping work

Take the following precautions on-site when connecting pipes. (Keep in mind that the need to control the entry of moisture and dust is even more important than in conventional piping).

- a. Keep the open ends of all pipes sealed until connection with AC equipment is complete.
- b. Take special care when doing piping work on rainy days. The entering of moisture will degrade the refrigerating machine oil, and lead to malfunctions in the equipment.
- c. Complete all pipe connections in as short a time as possible. If the pipe must be left standing for a long time after removing the seal, it must be thoroughly purged with nitrogen, or dried with a vacuum pump.

10.4. INSTALLATION, TRANSFERRING, SERVICING

10.4.1. Inspecting Gas Leaks with a Vacuum Pump for New Installations (Using New Refrigerant Piping)

1. From the viewpoint of protecting the global environment, please do not release refrigerant into the atmosphere.
 - a. Connect the projecting side (pin-pushing side) of the charging hose for the manifold gauge to the service port of the 3-way valve. (1)
 - b. Fully open the handle Lo of the manifold gauge and run the vacuum pump. (2) (If the needle of the low-pressure gauge instantly reaches vacuum, re-check step a.)
 - c. Continue the vacuum process for at least 15 minutes, then check to make sure the low-pressure gauge has reached -0.1 MPa (-76 cmHg). Once the vacuum process has finished, fully close the handle Lo of the manifold gauge and stop the vacuum pump operation, then remove the charging hose that is connected to the vacuum pump adaptor. (Leave the unit in that condition for 1-2 minutes, and make sure that the needle of the manifold gauge does not return.) (2) and (3)
 - d. Turn the valve stem of the 2-way valve 90 counter-clockwise to open it, then, after 10 seconds, close it and inspect for a gas leak (4)
 - e. Remove the charging hose from the 3-way valve service port, then open both the 2-way valve and 3-way valve. (1) (4) (Turn the valve stem in the counter-clockwise direction until it gently makes contact. Do not turn it forcefully).
 - f. Tighten the service port cap with a torque wrench (18 N.m (1.8 kgf.m)). (5) Then tighten the 2-way valve and 3-way valve caps with a torque wrench (42 N.m (4.2 kgf.m)) or (55 N.m (5.5 kgf.m)).
 - g. After attaching each of the caps, inspect for a gas leak around the cap area. (5) (6)

Precautions

- Be sure to read the instructions for the vacuum pump, vacuum pump adaptor and manifold gauge prior to use, and follow the instructions carefully.
- Make sure that the vacuum pump is filled with oil up to the designated line on the oil gauge.
- The gas pressure back flow prevention valve on the charging hose is generally open during use. When you are removing the charging hose from the service port, it will come off more easily if you close this valve.

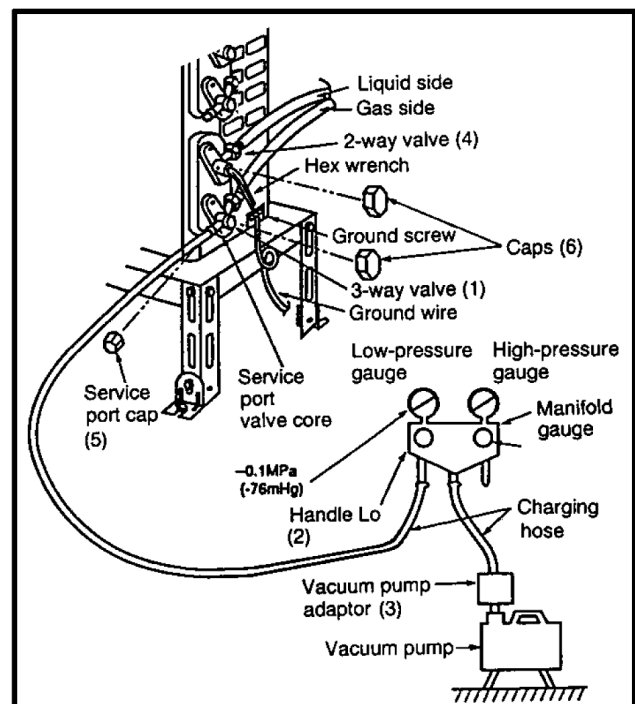

Fig. 12 Vacuum pump air purging configuration

10.4.2. Transferring (Using New Refrigerant Piping)

1. Removing the unit

a. Collecting the refrigerant into the outdoor unit by pumping down

The refrigerant can be collected into the outdoor unit (pumping down) by pressing the TEST RUN button, even when the temperature of the room is low.

- Check to make sure that the valve stems of the 2-way valve and 3-way valve have been opened by turning them counter-clockwise. (Remove the valve stem caps and check to see that the valve stems are fully opened position. Always use a hex wrench (with 4-mm opposing sides) to operate the valve stems.)
- Press the TEST RUN button on the indoor unit, and allow preliminary for 5-6 minutes. (TEST RUN mode)
- After stopping the operation, let the unit sit for about 3 minutes, then close the 2-way valve by turning the valve stem in the clockwise direction.
- Press the TEST RUN button on the indoor unit again, and after 2-3 minutes of operation, turn the valve stem of the 3-way valve quickly in the clockwise direction to close it, then stop the operation.
- Tighten the caps of the 2-way valve and 3-way valve to the stipulated torque.
- Remove the connection pipes (liquid side and gas side).

2. Installing the unit

Install the unit using new refrigerant piping. Follow the instructions in section 4.1 to evacuate the pipes connecting the indoor and outdoor units, and the pipes of the indoor unit, and check for gas leaks.

10.4.3. AC Units Replacement (Using Existing Refrigerant Piping)

When replacing an R410A AC unit with another R410A AC unit, you should re-flare the refrigerant piping. Even though the replacement AC unit uses the R410A, problems occur when, for example, either the AC unit maker or the refrigerating machine oil is different.

When replacing an R22 AC unit with an R410A AC unit, the following checks and cleaning procedures are necessary but are difficult to do because of the chemical characteristics of the refrigerating machine oil (as described in items c) and d) of section 10.1.1.(2)). In this case, you should use new refrigerant piping rather than the existing piping.

1. Piping check

Because of the different pressure characteristics of R22 and R410A, the design pressure for the equipment is 1.6 times different. The wall thickness of the piping must comply with that shown in Table 10, but this is not easy to check. Also, even if the thickness is correct, there may be flattened or bent portions midway through the piping due to sharp curves. Buried sections of the piping also cannot be checked.

2. Pipe cleaning

A large quantity of refrigerating machine oil (mineral oil) adheres to existing pipes due to the refrigeration cycle circulation. If the pipes are used just as they are for the R410A cycle, the capacity will be lowered due to the incompatibility of this oil with the R410A, or irregularities may occur in the refrigeration cycle. For this reason, the piping must be thoroughly cleaned, but this is difficult with the present technology.

10.4.4. Refrigerant Compatibility (Using R410A Refrigerant in R22 ACs and Vice Versa)

Do not operate an existing R22 AC with the new R410A refrigerant. Doing so would result in improper functioning of the equipment or malfunction, and might lead to a major accident such as an explosion in the refrigeration cycle. Similarly, do not operate an R410A AC with R22 refrigerant. The chemical reaction between the refrigerating machine oil used in R410A ACs and the chlorine that is contained in R22 would cause the refrigerating machine oil to degrade and lead to malfunction.

10.4.5. Recharging Refrigerant During Servicing

When recharging is necessary, insert the specified amount of new refrigerant in accordance with the following procedure.

1. Connect the charging hose to the service port of the outdoor unit.
2. Connect the charging hose to the vacuum pump adaptor. At this time, fully open the 2-way valve and 3-way valve.
3. Fully open the handle Lo of the manifold gauge, turn on the power of the vacuum pump and continue the vacuum process for at least one hour.
4. Confirm that the low pressure gauge shows a reading of -0.1 Mpa (-76 cmHg), then fully close the handle Lo, and turn off the vacuum pump. Wait for 1-2 minutes, then check to make sure that the needle of the Low pressure gauge has not returned. See Fig. 13 for the remaining steps of this procedure.

- Set the refrigerant cylinder onto the electronic scale, then correct the hose the cylinder and to the connection port for the electronic scale. (1)(2)

Precaution:

Be sure to set up the cylinder for liquid charging. If you use a cylinder equipped with a siphon tube, you can charge the liquid without having to turn the cylinder around

- Remove the charging hose of the manifold gauge from the vacuum pump adaptor, and connect it to the connection port of the electronic scale. (2)(3)
- Open the valve of the refrigerant cylinder, then open the charging valve slightly and close it. Next, press the check valve of the manifold gauge and purge the air. (2)(4) (Watch the liquid refrigerant closely at this point.)
- After adjusting the electronic scale to zero, open the charging valve, then open the valve Lo of the manifold gauge and charge with the liquid refrigerant. (2)(5) (Be sure to read the operating instructions for the electronic scale.)
- If you cannot charge the stipulated amount, operate the unit in the cooling mode while charging a little of the liquid at a time (about 150 g/time as a guideline). If the charging amount is insufficient from one operation, wait about one minute, then use the same procedure to do the liquid charging again.

Precaution:

Never use the gas side to allow a larger amount of liquid refrigerant to be charged while operating the unit.

- Close the charging valve, and after charging the liquid refrigerant inside the charging hose, fully close the valve Lo of the manifold gauge, and stop the operation of the unit. (2)(5)
- Quickly remove the charging hose from the service port. (6) If you stop midway through, the refrigerant that is in the cycle will be discharged.
- After putting on the caps for the service port and operating valve, inspect around the caps for a gas leak. (6)(7)

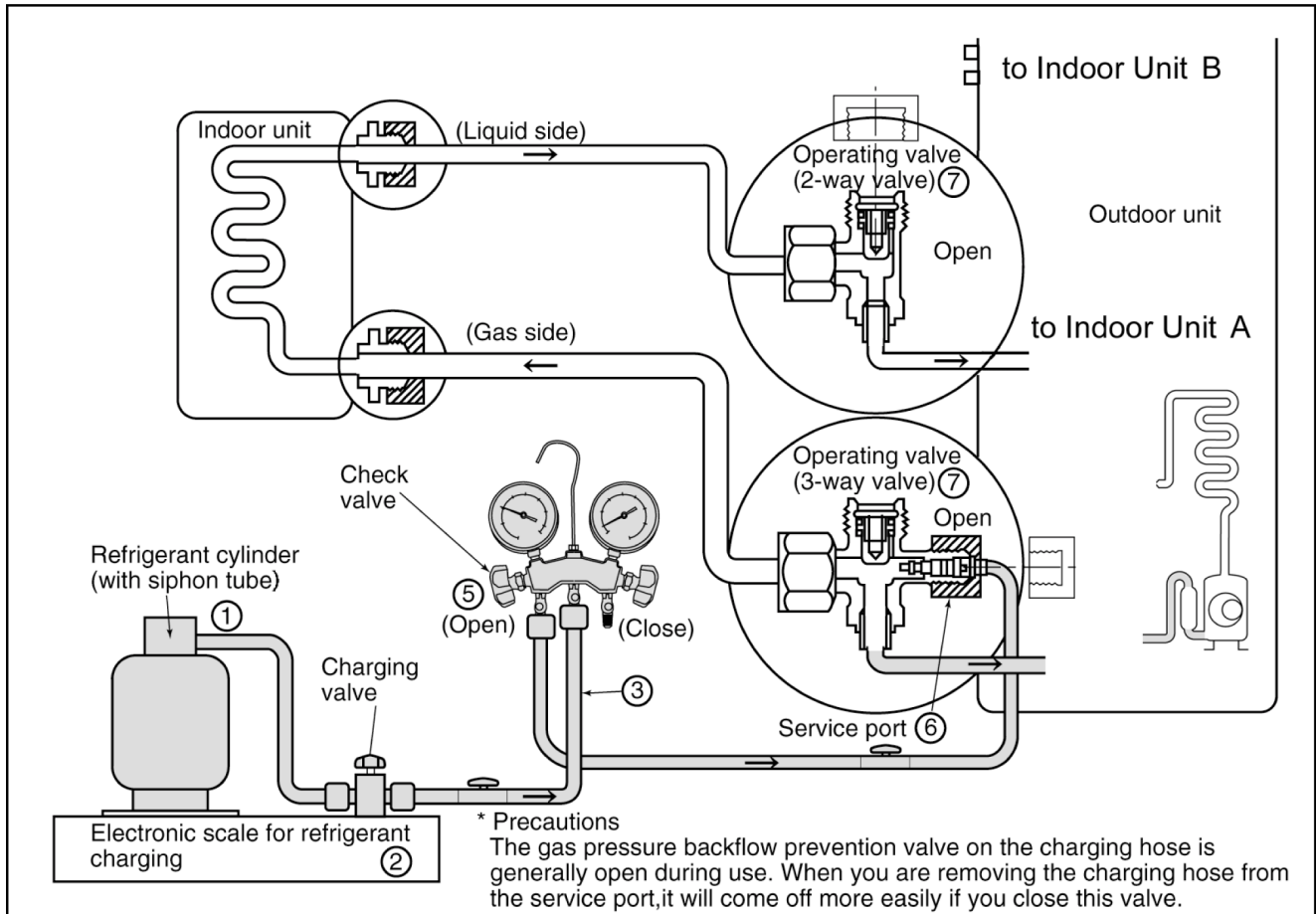

Fig. 13 Re-charging refrigerant

10.4.6. Brazing

As brazing requires sophisticated techniques and experiences, it must be performed by a qualified person. In order to prevent the oxide film from occurring in the pipe interior during brazing, it is effective to proceed with brazing while letting dry nitrogen gas (N₂) flow.

<Brazing Method for Preventing Oxidation>

1. Attach a reducing valve to the nitrogen gas cylinder.
2. Attach a reducing valve to the nitrogen gas cylinder.
3. Apply a seal onto the clearance between the piping and inserted pipe for the nitrogen gas in order to prevent the nitrogen gas from flowing backward.
4. When the nitrogen gas is flowing, be sure to keep the piping end open.
5. Adjust the flow rate of nitrogen gas so that it is lower than 0.05 m³/h, or 0.02 MPa (0.2 kgf/cm²) by means of the reducing valve.
6. After taking the steps above, keep the nitrogen gas flowing until the piping cools down to a certain extent (i.e. temperature at which pipes are touchable with finger).
7. Completely remove the flux after brazing.

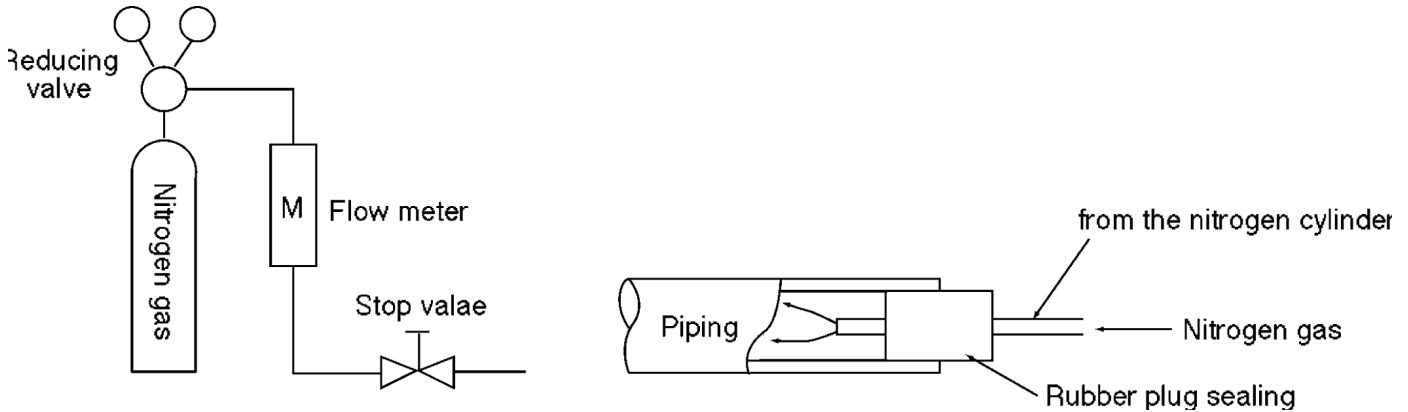

Cautions during brazing

1. General Cautions

- a. The brazing strength should be high as required.
- b. After operation, airtightness should be kept under pressurized condition.
- c. During brazing do not allow component materials to become damaged due to overheating.
- d. The refrigerant pipe work should not become blocked with scale or flux.
- e. The brazed part should not restrict the flow in the refrigerant circuit.
- f. No corrosion should occur from the brazed part.

2. Preventing of Overheating

Due to heating, the interior and exterior surfaces of treated metal may oxidize. Especially, when the interior of the refrigerant circuit oxidizes due to overheating, scale occurs and stays in the circuit as dust, thus exerting a fatally adverse effect. So, make brazing at adequate brazing temperature and with minimum of heating area.

3. Overheating Protection

In order to prevent components near the brazed part from overheating damaged or quality deterioration due to flame or heat, take adequate steps for protection such as (1) by shielding with a metal plate, (2) by using a wet cloth, and (3) by means of heat absorbent.

4. Movement during Brazing

Eliminate all vibration during brazing to protect brazed joints from cracking and breakage.

5. Oxidation Preventative

In order to improve the brazing efficiency, various types of antioxidant are available on the market. However, the constituents of these are widely varied, and some are anticipated to corrode the piping materials, or adversely affect HFC refrigerant, lubricating oil, etc. Exercise care when using an oxidation preventative.

10.4.7. Servicing Tips

The drier must also be replaced whenever replacing the refrigerant cycle parts. Replacing the refrigerant cycle parts first before replacing the drier. The drier is supplied in a vacuum pack. Perform brazing immediately after opening the vacuum pack, and then start the vacuum within two hours. In addition, the drier also needs to be replaced when the refrigerant has leaked completely.

11 Installation Instructions

Required tools for Installation Works			
1. Phillips screw driver	5. Spanner	9. Gas leak detector	13. Multimeter
2. Level gauge	6. Pipe cutter	10. Measuring tape	14. Torque wrench 18 N.m (1.8 kgf.m) 42 N.m (4.2 kgf.m) 55 N.m (5.5 kgf.m)
3. Electric drill, hole core drill ($\phi 70$ mm)	7. Reamer	11. Thermometer	15. Vacuum pump
4. Hexagonal wrench (4 mm)	8. Knife	12. Megameter	16. Gauge manifold

11.1. Safety Precautions

- Read this following “SAFETY PRECAUTIONS” carefully before installation.
- Electrical work must be installed by all licensed electrician. Be sure to use the correct rating of the power plug and main circuit for the model to be installed.
- The caution items stated here must be followed because these important contents are related to safety. The meaning of each indication used is as below.

Incorrect installation due to ignoring of the instruction will cause harm or damage, and the seriousness is classified by the following indication.



 WARNING	This indication shows the possibility of causing death or serious injury.
---	---

 CAUTION	This indication shows the possibility of causing injury or damage to properties only.
--	---

The items to be followed are classified by the symbols:

	Symbol with background white denotes item that is PROHIBITED from piping.
---	---

- Carry out test running to confirm that no abnormality occurs after the installation. Then, explain to user the operation, care and maintenance as stated in instruction. Please remind the customer to keep the operating instructions for future reference.

 WARNING	
1. Engage dealer or specialist for installation. If installation done by the user is defective, it will cause water leakage, electrical shock or fire.	
2. Install according to this installation instruction strictly. If installation is defective, it will cause water leakage, electrical shock or fire.	
3. Use the attached accessories parts and specified parts for installation. Otherwise, it will cause the set to fall, water leakage, fire or electrical shock.	
4. Install at a strong and firm location which is able to withstand the set's weight. If the strength is not enough or installation is not properly done, the set will drop and cause injury.	
5. For electrical work, follow the local national wiring standard, regulation and this installation instruction. An independent circuit and single outlet must be used. If electrical circuit capacity is not enough or defect found in electrical work, it will cause electrical shock or fire.	
6. Use the specified cable (1.5 mm ²) and connect tightly for indoor/outdoor connection. Connect tightly and clamp the cable so that no external force will be acted on the terminal. If connection or fixing is not perfect, it will cause heat-up or fire at the connection.	
7. Wire routing must be properly arranged so that control board cover is fixed properly. If control board cover is not fixed perfectly, it will cause heat-up at connection point of terminal, fire or electrical shock.	
8. When carrying out piping connection, take care not to let air substances other than the specified refrigerant go into refrigeration cycle. Otherwise, it will cause lower capacity, abnormal high pressure in the refrigeration cycle, explosion and injury.	
9. When connecting the piping, do not allow air or any substances other than the specified refrigerant (R410A) to enter the refrigeration cycle. Otherwise, this may lower the capacity, cause abnormally high pressure in the refrigeration cycle, and possibly result in explosion and injury.	



WARNING

10. • When connecting the piping, do not use any existing (R22) pipes and flare nuts. Using such same may cause abnormally high pressure in the refrigerant cycle (piping), and possibly result in explosion and injury. Use only R410A materials.
- Thickness of copper pipes used with R410A must be more than 0.08 mm. Never use copper pipes thinner than 0.08 mm.
- It is desirable that the amount of residual oil is less than 40 mg/ 10 m.



11. Do not modify the length of the power supply cord or use of the extension cord, and do not share the single outlet with other electrical appliances. Otherwise, it will cause fire or electrical shock.



CAUTION

1. Grounding is necessary. It may cause electrical shock if grounding is not perfect.

2. Do not install the unit at place where leakage of flammable gas may occur. In case gas leaks and accumulates at surrounding of the unit, it may cause fire.







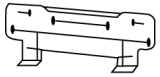

3. Carry out drainage piping as mentioned in installation instructions. If drainage is not perfect, water may enter the room and damage the furniture.

ATTENTION

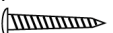
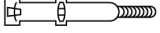
1. Selection of the installation location.
Select a installation location which is rigid and strong enough to support or hold the unit, and select a location for easy maintenance.
2. Power supply connection to the room air conditioner.
Connect the power supply cord of the room air conditioner to the mains using one of the following method.
Power supply point shall be the place where there is ease for access for the power disconnection in case of emergency. In some countries, permanent connection of this room air conditioner to the power supply is prohibited.
1. Power supply connection to the receptacle using a power plug. Use an approved 16A power plug with earth pin for the connection to the receptacle.
 2. Power supply connection to a circuit breaker for the permanent connection. Use an approved 16A circuit breaker for the permanent connection. It must be a double pole switch with a minimum 3 mm contact gap.
3. Do not release refrigerant.
Do not release refrigerant during piping work for installation, re-installation and during repairing a refrigeration parts. Take care of the liquid refrigerant, it may cause frostbite.
4. Installation work.
It may need two people to carry out the installation work.
5. Do not install this appliance in a laundry room or other location where water may drip from the ceiling, etc.

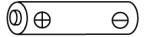
Attached accessories

No.	Accessories part	Qty.	No.	Accessories part	Qty.
1	Installation plate 	1	5	Air purifying filter 	2
2	Installation plate fixing screw 	4	6	Band 	1
3	Remote control 	1	7	Remote Control holder 	1
4	Battery 	2	8	Remote Control holder fixing screw 	2

Applicable piping kit

CZ-3F5, 7AEN (CS/CU-VC75KE, VC95KE)

CZ-4F5, 7, 10AN (CS/CU-VC125KE)

SELECT THE BEST LOCATION

INDOOR UNIT

- There should not be any heat source or steam near the unit.
- There should not be any obstacles blocking the air circulation.
- A place where air circulation in the room is good.
- A place where drainage can be easily done.
- A place where noise prevention is taken into consideration.
- Do not install the unit near the door way.
- Ensure the spaces indicated by arrows from the wall, ceiling, or other obstacles.
- Indoor unit of this room air conditioner shall be installed on the wall in a height of at least 2.3 m.

OUTDOOR UNIT

- If an awning is built over the unit to prevent direct sunlight or rain, be careful that heat radiation from the condenser is not obstructed.
- There should not be any animal or plant which could be affected by hot air discharged.
- Keep the spaces indicated by arrows from wall, ceiling, fence or other obstacles.
- Do not place any obstacles which may cause a short circuit of the discharged air.
- If piping length is over the common length, additional refrigerant should be added as shown in the table.

Model	Piping size		Common Length (m)	Max. Elevation (m)	Max. Piping Length (m)	Additional Refrigerant (g/m)
	Gas	Liquid				
VC75/95KE	3/8"	1/4"	7.5	5	10	-
VC125KE	1/2"	1/4"	7.5	5	15	15

Indoor/Outdoor unit installation diagram

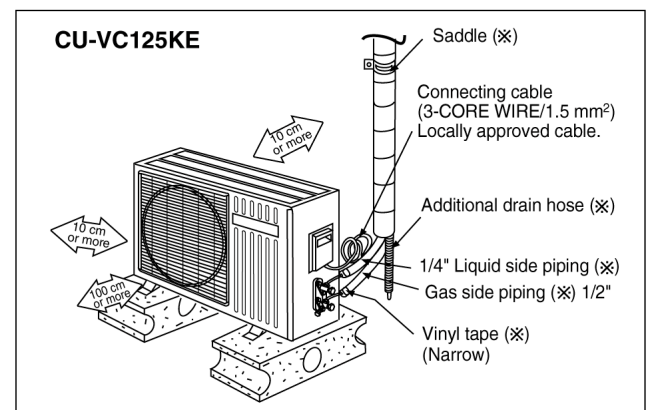
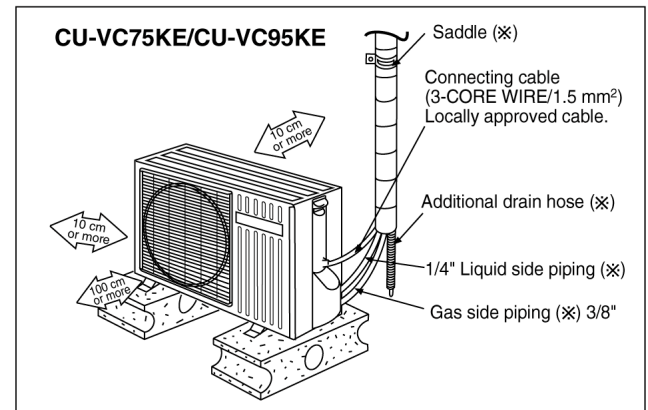
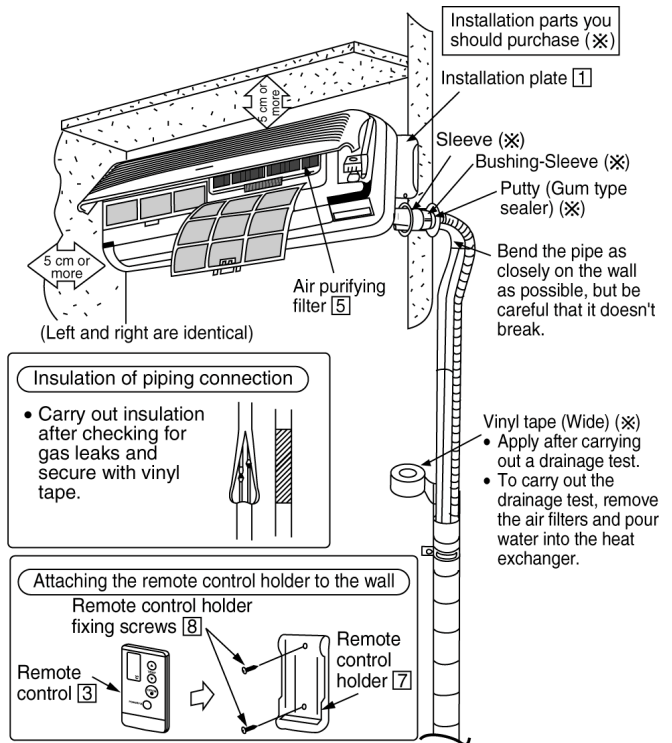
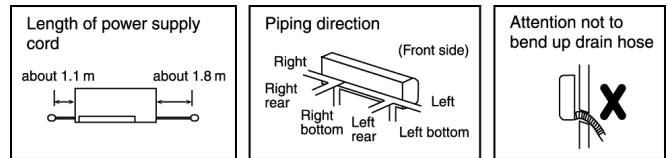

• This illustration is for explanation purposes only. The indoor unit will actually face a different way.

11.2. INDOOR UNIT

11.2.1. SELECT THE BEST LOCATION (Refer to “Select the best location” section)

11.2.2. HOW TO FIX INSTALLATION PLATE

The mounting wall is strong and solid enough to prevent it from the vibration.

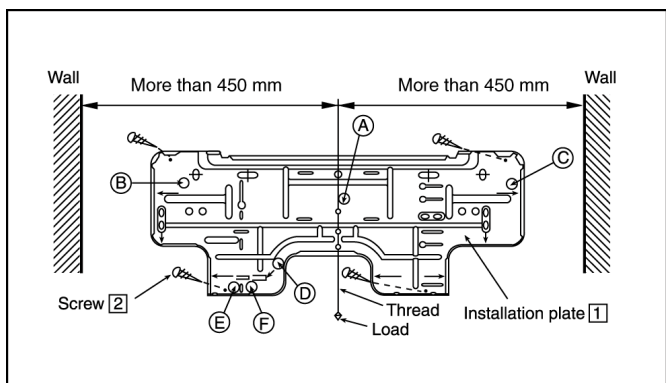

- (A) : Unit centre should be at more than 450 mm at right and left of the wall.
The height should be more than 195 mm from the ceiling.
- (B) : From installation plate end to unit left side end is 50 mm.
- (C) : From installation plate end to unit right side end is 50 mm.
- (D) : Connecting cable should be about 750 mm from this line.
(Only for left rear piping)
- (E) : For left side piping, piping connection for liquid should be here.
- (F) : For left side piping, piping connection for gas should be here.

1. Mount the installation plate on the wall with four screws.
(If mounting the unit on the concrete wall consider using anchor bolts.)

- Always mount the installation plate horizontally by aligning the marking-off line with the thread and using a level gauge.

2. Drill the piping plate hole with $\phi 70$ mm hole-core drill.

- Line according to the arrows marked on the lower left and right side of the installation plate. The meeting point of the extended line is the centre of the hole.
- Drill the piping hole at either the right or the left and the hole should be slightly slanted to the outdoor side.

11.2.3. TO DRILL A HOLE IN THE WALL AND INSTALL A SLEEVE OF PIPING

1. Insert the piping sleeve to the hole.
2. Fix the bushing to the sleeve.
3. Cut the sleeve until it extrudes about 15 mm from the wall.

Caution

When the wall is hollow, please be sure to use the sleeve for tube ass'y to prevent dangers caused by mice biting the indoor/outdoor connecting cable.

4. Finish by sealing the sleeve with putty or caulking compound at the final stage.

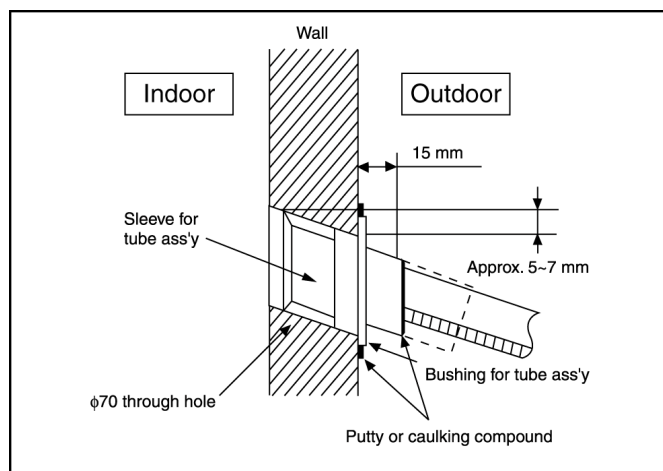

11.2.4. INDOOR UNIT INSTALLATION

1. For the right rear piping

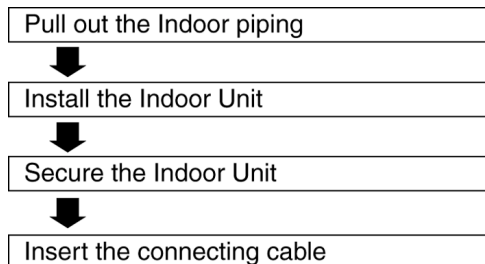

2. For the right and right bottom piping

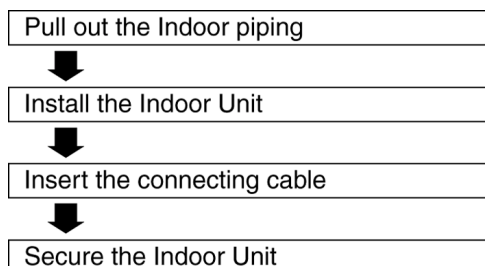

3. For the embedded piping

- Replace the drain hose
- ↓
- Bend the embedded piping
- ↓
- Use a spring bender or equivalent to bend the piping so that the piping is not crushed.
- Install the Indoor Unit
- ↓
- Cut and flare the embedded piping
- ↓
- When determining the dimension of the piping, slide the unit all the way to the left on the installation plate.
Refer to the section "Cutting and flaring the piping".
- Pull the connecting cable into Indoor Unit
- ↓
- The inside and outside connecting cable can be connected without removing the front grille.
- Connect the piping
- ↓
- Please refer to "Connecting the piping" column in outdoor unit section. (Below steps are done after connecting the outdoor piping and gas-leakage confirmation.)
- Insulate and finish the piping
- ↓
- Please refer to "Piping and finishing" column of outdoor section and "Insulation of piping connections" column as mentioned in Indoor/Outdoor Unit Installation.
- Install clamping cover of piping
- ↓
- Refer to figure on next page.
- Secure the Indoor Unit

Install the indoor unit

Hook the indoor unit onto the upper portion of installation plate (Engage the indoor unit with the upper edge of the installation plate). Ensure the hooks are properly seated on the installation plate by moving it in left and right.

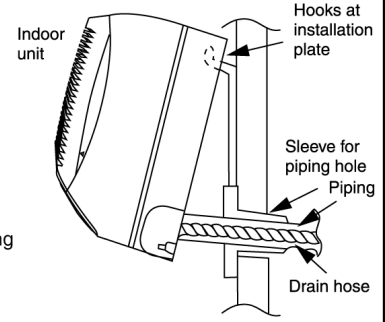

Secure the indoor unit

1. Tape the extra power supply cord in a bundle and keep it behind the chassis.
 - Ensure that the power supply cord is not clamped in between the unit's hook (2 positions) and installation plate
2. Press the lower left and right side of the unit against the installation plate until hooks engages with their slots (sound click).

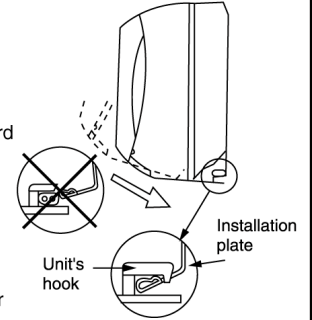

Pull out the piping and drain hose

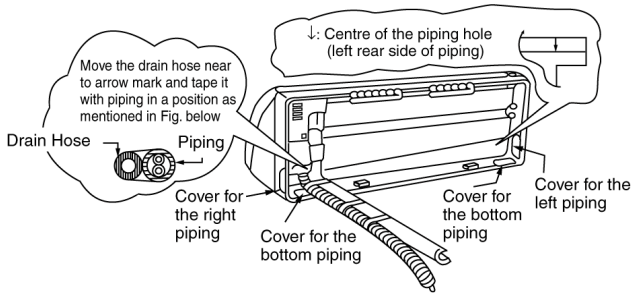

To take out the unit, push the [PUSH] marking at the bottom unit, and pull it slightly towards you to disengage the hooks from the unit.

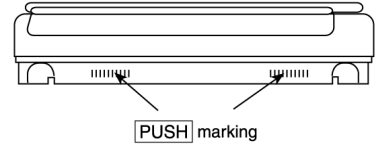

(This can be used for left rear piping and left bottom piping also.)

Exchange the drain hose and the cap

Refer view for left piping installation

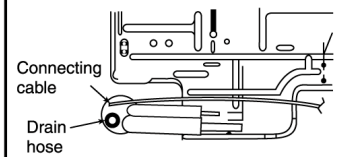
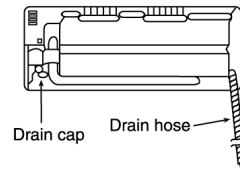

Adjust the piping slightly downwards

Insert the connecting cable

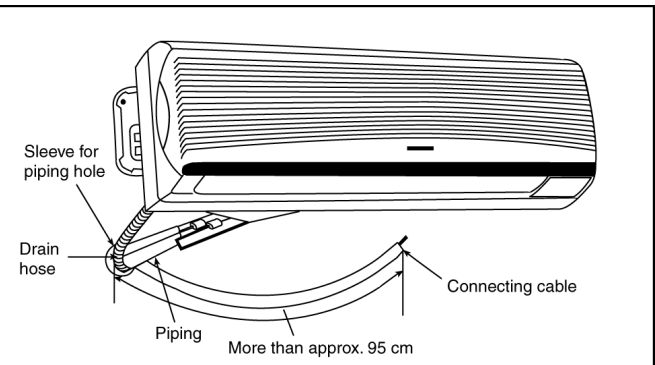
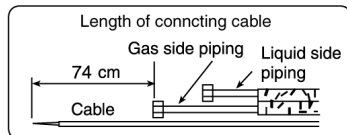
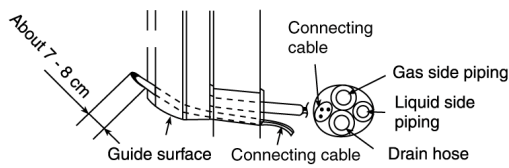

- How to pull the piping and drain hose out, in case of the embedded piping.

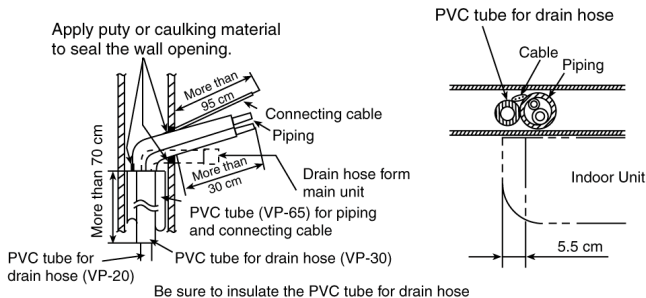

11.2.5. CONNECT THE CABLE TO THE INDOOR UNIT

1. The inside and outside connecting cable can be connected without removing the front grille.
2. Connecting cable between indoor unit and outdoor unit shall be approved polychloroprene sheathed $3 \times 1.5 \text{ mm}^2$ flexible cord, type designation H05 RN-F or heavier cord.
 - Ensure the color of wires of outdoor unit and the terminal Nos. are the same to the Indoor's respectively.
 - Earth lead wire shall be longer than the other lead wires as shown in the figure for the electrical safety in case of the slipping out of the cord from the anchorage.

Terminals on the indoor unit	1	2	
Color of wires			
Terminals on the outdoor unit	1	2	

- Secure the cable onto the control board with the holder (clamer).

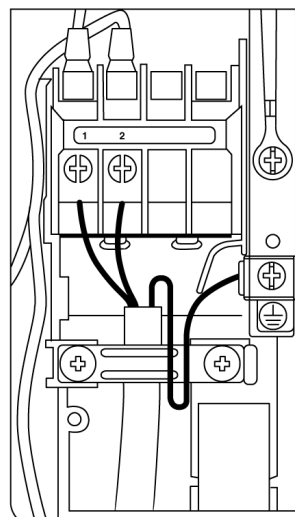

ATTACHMENT OF THE PIPING BAND

- For the right rear piping, it is not necessary to use piping band. The piping band can be attached when the extension flare pipe is used or when doing the piping work (under condition as shown in the diagram below) on the floor.
- The location to attach the piping band change according to the direction of the piping. Press the band knot to the hole in order to fix the band as shown in diagram below.

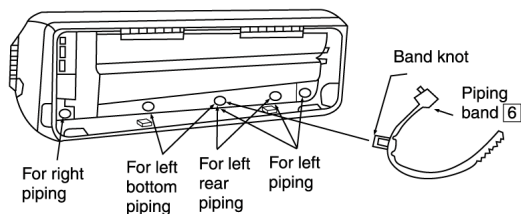

- Tighten the band so that the cable and the piping are secure. Be sure to cut any excess from the piping band (failure to cut away the excess piping band may produce abnormal noise during operation of condensation).

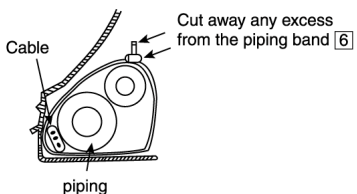

- In case of left piping how to insert the connecting cable and drain hose.

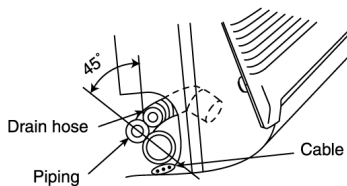

(For the right piping, follow the same procedure)

INSTALLATION OF AIR PURIFYING FILTERS

1. Open the front panel.
2. Remove the air filters.
3. Hold the purifying filters by their tabs and install as shown in the illustration at below.

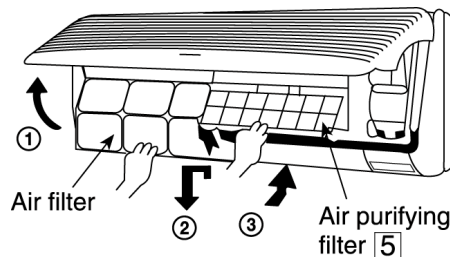

HOW TO TAKE OUT FRONT GRILLE

Please follow below steps to take out front grille if necessary such as when servicing.

1. Set the vertical airflow direction louver to the horizontal position.
2. Slide down the two caps on the front grille as shown in the illustration below, and then remove the two mounting screws.
3. Pull the lower section of the front grille towards you to remove the front grille.

When reinstalling the front grille, first set the vertical airflow direction louver to the horizontal position and then carry out above steps 2 - 3 in the reverse order.

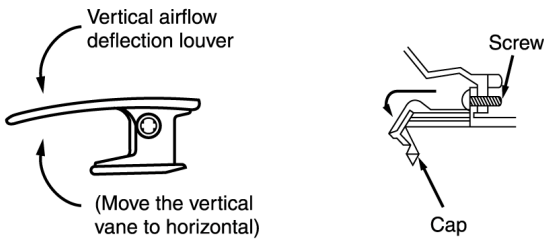

AUTO SWITCH OPERATION

The below operations will be performed by pressing the "AUTO" switch.

1. AUTO OPERATION MODE

The Auto operation will be activated immediately once the Auto Switch is pressed.

2. TEST RUN OPERATION (FOR PUMP DOWN/SERVICING PURPOSE)

The Test Run operation will be activated if the Auto Switch is pressed continuously for more than 5 sec. to below 10 sec. A "beep" sound will occur at the fifth sec., in order to identify the starting of Test Run operation

3. REMOTE CONTROLLER RECEIVING SOUND ON/OFF

The ON/OFF of Remote Controller receiving sound can be change over by pressing the "AUTO" Switch continuously for 10 sec. and above. A "beep", "beep" sound will occur at the tenth sec., in order to indicate the "ON/OFF" change over of remote control receiving sound.

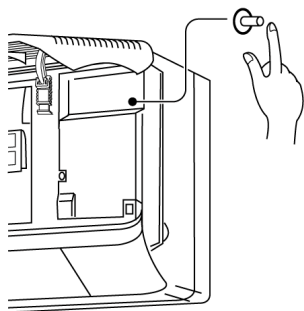

11.3. OUTDOOR UNIT

11.3.1. SELECT THE BEST LOCATION (Refer to "Select the best location" section)

11.3.2. INSTALL THE OUTDOOR UNIT

- After selecting the best location, start installation according to Indoor/outdoor Unit Installation Diagram.
1. Fix the unit on concrete or rigid frame firmly and horizontally by bolt nut. (ø10 mm).
 2. When installing at roof, please consider strong wind and earthquake. Please fasten the installation stand firmly with bolt or nails.

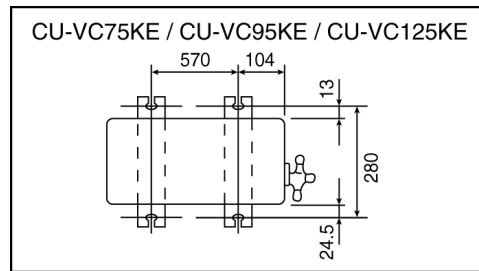

11.3.3. CONNECTING THE PIPING

Connecting the Piping to Indoor Unit

Please make flare after inserting flare nut (locate at joint portion of tube assembly) onto the copper pipe. (In case of using piping)

Connect the piping

- Align the center of piping and sufficiently tighten the flare nut with fingers.
- Further tighten the flare nut with torque wrench in specified torque as stated in the table.

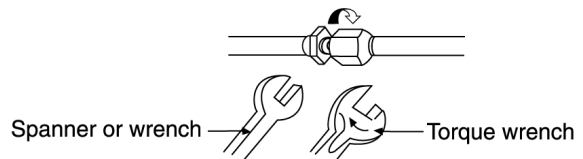

MODEL	Piping size (Torque)	
	Gas	Liquid
VC75KE/VC95KE	3/8" (42 N.m)	1/4" (18 N.m)
VC125KE	1/2" (55 N.m)	1/4" (18 N.m)

Connecting the Piping to Outdoor Unit

Decide piping length and then cut by using pipe cutter. Remove burrs from cut edge. Make flare after inserting the flare nut (located at valves) onto the copper pipe.

Align center of piping to valves and then tighten with torque wrench to the specified torque as stated in the table.

CUTTING AND FLARING THE PIPING

1. Please cut using pipe cutter and then remove the burrs.
2. Remove the burrs by using reamer. If burrs is not removed, gas leakage may be caused.
Turn the piping and down to avoid the metal powder entering the pipe.
3. Please make flare after inserting the flare nut onto the copper pipes.

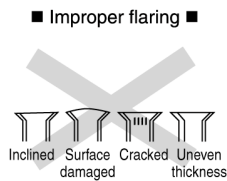
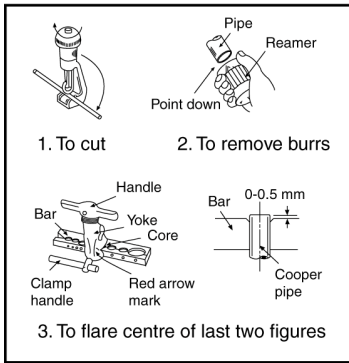

When properly flared, the internal surface of the flare will evenly shine and be of even thickness. Since the flare part comes into contact with the connectors, carefully check the flare finish.

5. Disconnect the charging hose from the vacuum pump and from the service port of the 3-way valve.
6. Tighten the service port caps of the 3-way valve at torque of 18 N.m with a torque wrench.
7. Remove the valve caps of both of the 2-way valve and 3-way valve. Position both of the valves to "OPEN" using a hexagonal wrench (4 mm).
8. Mount valve caps onto the 2-way valve and the 3-way valve.
 - Be sure to check for gas leakage.
9. The service port located near condenser coil is applied for winter operation kit, which is used during cooling mode operation in winter season.
 - The size of service port is 1/4" and tightening torque is N.m.

CAUTION

- If gauge needle does not move from 0 cmHg (0 MPa) to -76 cmHg (-0.1 MPa), in step 3 above take the following measure:
- If the leak stops when the piping connections are tightened further, continue working from step 3.
- If the leak does not stop when the connections are retightened, repair the location of leak.
- Do not release refrigerant during piping work for installation and re-installation. Take care of the liquid refrigerant, it may cause frostbite.

11.3.4. EVACUATION OF THE EQUIPMENT

WHEN INSTALLING AND AIR CONDITIONER, BE SURE TO EVACUATE THE AIR INSIDE THE INDOOR UNIT AND PIPES in the following procedure.

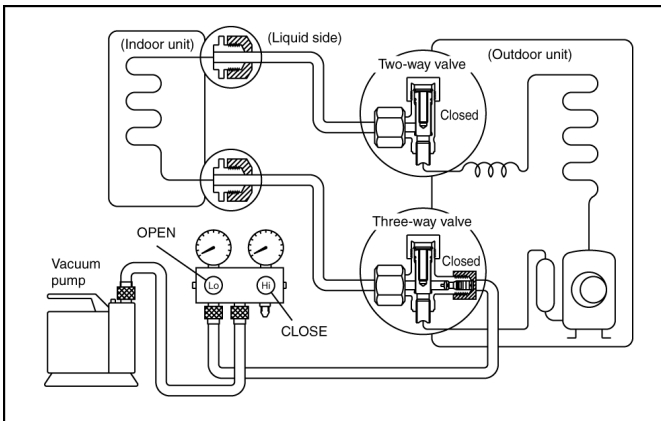

1. Connect a charging hose with a push pin to the Low and High side of a charging set and the service port of the 3-way valve.
 - Be sure to connect the end of the charging hose with the push pin to the service port.
2. Connect the center hose of the charging set to a vacuum pump.
3. Turn on the power switch of the vacuum pump and make sure that the needle in the gauge moves from 0 cmHg (0 MPa) to -76 cmHg (-0.1 MPa). Then evacuate the air approximately ten minutes.
4. Close the valve of both the Low and High sides of the charging set and turn off the vacuum pump. Make sure that the needle in the gauge does not move after approximately five minutes.

Note: BE SURE TO TAKE THIS PROCEDURE IN ORDER TO AVOID REFRIGERANT GAS LEAKAGE.

11.3.5. CONNECT THE CABLE TO THE OUTDOOR UNIT

1. Remove the control board cover from the unit by loosening the screw.
2. Connecting cable between indoor unit and outdoor unit shall be approved polychloroprene sheathed 3 × 1.5 mm² flexible cord, type designation H05 RN-F or heavier cord.

Terminals on the indoor unit	1	2	
Color of wires			
Terminals on the outdoor unit	1	2	

3. Secure the cable onto the control board with the holder (clammer).
4. Attach the control board cover back to the original position with the screw.

11.3.6. PIPE INSULATION

1. Please carry out insulation at pipe connection portion as mentioned in Indoor/Outdoor Unit Installation Diagram. Please wrap the insulated piping end to prevent water from going inside the piping.
2. If drain hose or connecting piping is in the room (where dew may form), please increase the insulation by using POLY-E FOAM with thickness 6 mm or above.

CHECK THE DRAINAGE

- Open front panel and remove air filters.
(Drainage checking can be carried out without removing the front grille.)
- Pour a glass of water into the drain tray-styrofoam.
- Ensure that water flows out from drain hose of the indoor unit.

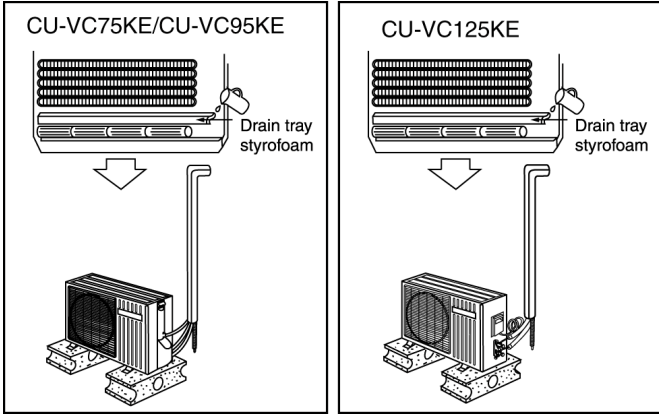

EVALUATION OF THE PERFORMANCE

- Operate the unit at cooling operation mode for fifteen minutes or more.
- Measure the temperature of the intake and discharge air.
- Ensure the difference between the intake temperature and the discharge is more than 8°C.

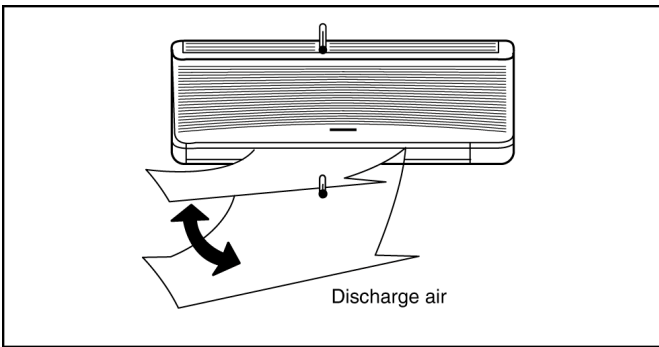

NOTE

These equipment shall be connected to a suitable mains network with a main impedance less than the following:
CS-VC95KE / CU-VC95KE: 0.46 Ω

NOTE

These equipment shall be connected to a suitable mains network with a main impedance less than the following:
CS-VC125KE / CU-VC125KE: 0.32 Ω

CHECK ITEMS

- Is there any gas leakage at flare nut connections?
- Has the heat insulation been carried out at flare nut connection?
- Is the indoor/outdoor connecting cable being fixed to terminal board firmly?
- Is the connecting cable being clamped firmly?
- Is the drainage OK?
(Refer to "Check the drainage" section)
- Is the earth wire connection properly done?
- Is the indoor unit properly hooked to the installation plate?
- Is the power supply voltage complied with rated value?
- Is there any abnormal sound?
- Is the cooling operation normal?
- Is the thermostat operation normal?
- Is the remote control's LCD operation normal?
- Is the air purifying filter installed?

12 2-way, 3-way Valve

	2-way Valve (Liquid Side)	3-way Valve (Gas Side)	
Works	Shaft Position	Shaft Position	Service Port
Shipping	Close (With valve cap)	Closed (With valve cap)	Closed (With cap)
Evacuation (Installation and Re-installation)	Closed (Counter-Clockwise)	Closed (Clockwise)	Open (Push-pin)
Operation	Open (With valve cap)	Open (With valve cap)	Closed (With cap)
Pumping down (Transferring)	Closed (Clockwise)	Open (Counter-Clockwise)	Open (Connected manifold gauge)
Evacuation (Servicing)	Open	Open	Open With vacuum pump
Gas charging (Servicing)	Open	Open	Open (With charging cylinder)
Pressure check (Servicing)	Open	Open	Open (Connected manifold gauge)
Gas releasing (Servicing)	Open	Open	Open (Connected manifold gauge)

12.1. Evacuation of Installation

WHEN INSTALLING AN AIR CONDITIONER, BE SURE TO EVACUATE THE AIR INSIDE THE INDOOR UNIT AND PIPES in the following procedure.

If air remain in the indoor unit and refrigeration pipes, it will affect the compressor, reduce to cooling capacity, and could lead to a malfunction.

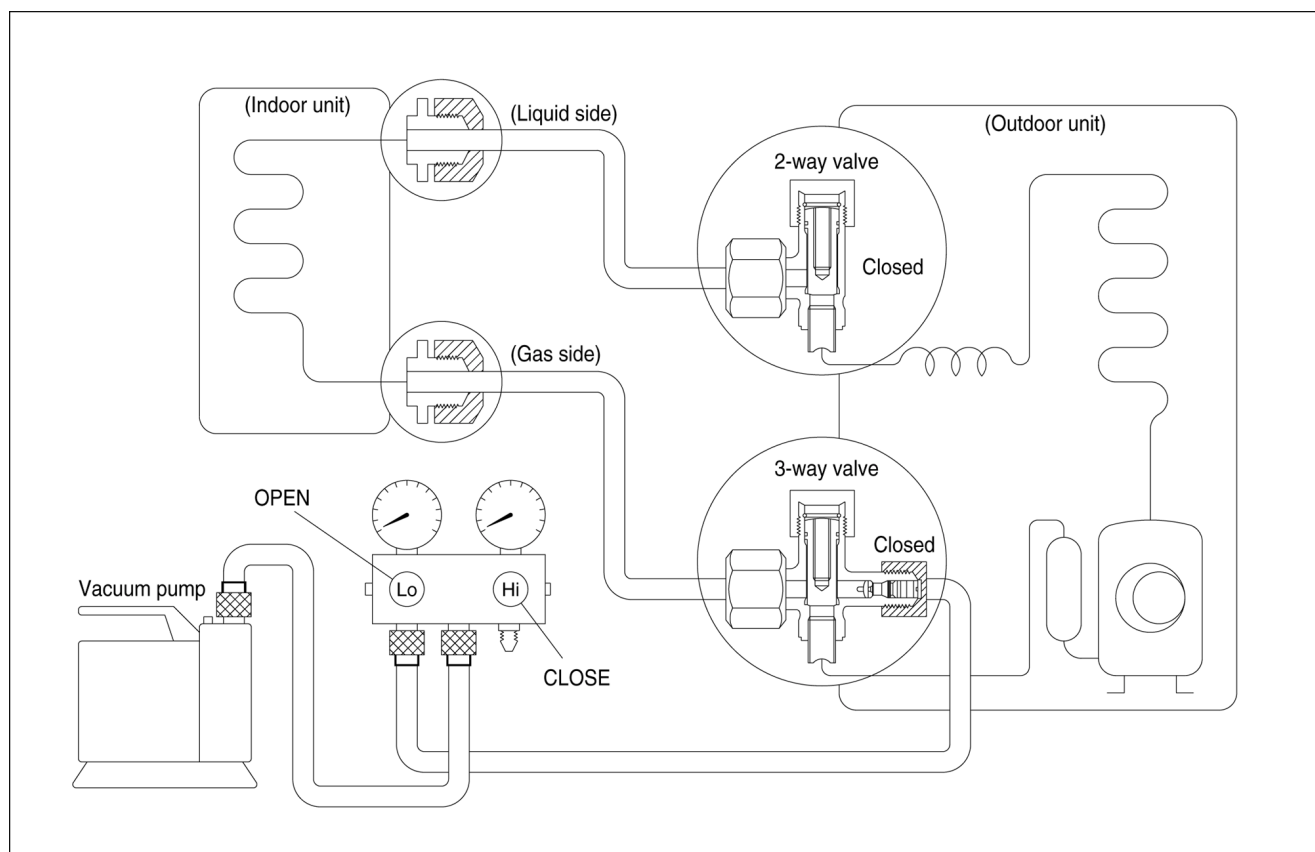

Procedure:

1. Connect a charging hose with a push pin to the Low side of a charging set and the service port of a 3-way valve.
 - Be sure to connect the end of the charging hose with the push pin to the service port.
2. Connect the centre hose of the charging set to a vacuum pump.
3. Turn on the power switch of the vacuum pump and make sure that the needle in the gauge moves from 0 MPa (0 cmHg) to -0.1 MPa (-76 cmHg). Then evacuate the air for approximately ten minutes.
4. Close the Low side valve of the charging set and turn off the vacuum pump. Make sure that the needle in the gauge does not move after approximately five minutes. **BE SURE TO TAKE THIS PROCEDURE IN ORDER TO AVOID GAS LEAKAGE.**
5. Disconnect the charging hose from the vacuum pump and from the service port of the 3-way valve.
6. Tighten the service port cap at a torque of 18 N.m with a torque wrench.
7. Remove the valve caps of the 2-way valve and the 3-way valve. Position both of the valves to "open" using a hexagonal wrench (4 mm).
8. Mount the valve caps onto the 2-way and 3-way valves.
 - Be sure to check for gas leakage.

Caution

If gauge needle does not move from 0 cmHg to -76 cmHg in step (3) above, take the following measures:

If the leaks stop when the piping connections are tightened further, continue working from step (3).

If the leaks do not stop when the connections are retightened, repair the location of the leak.

12.2. Pumping down

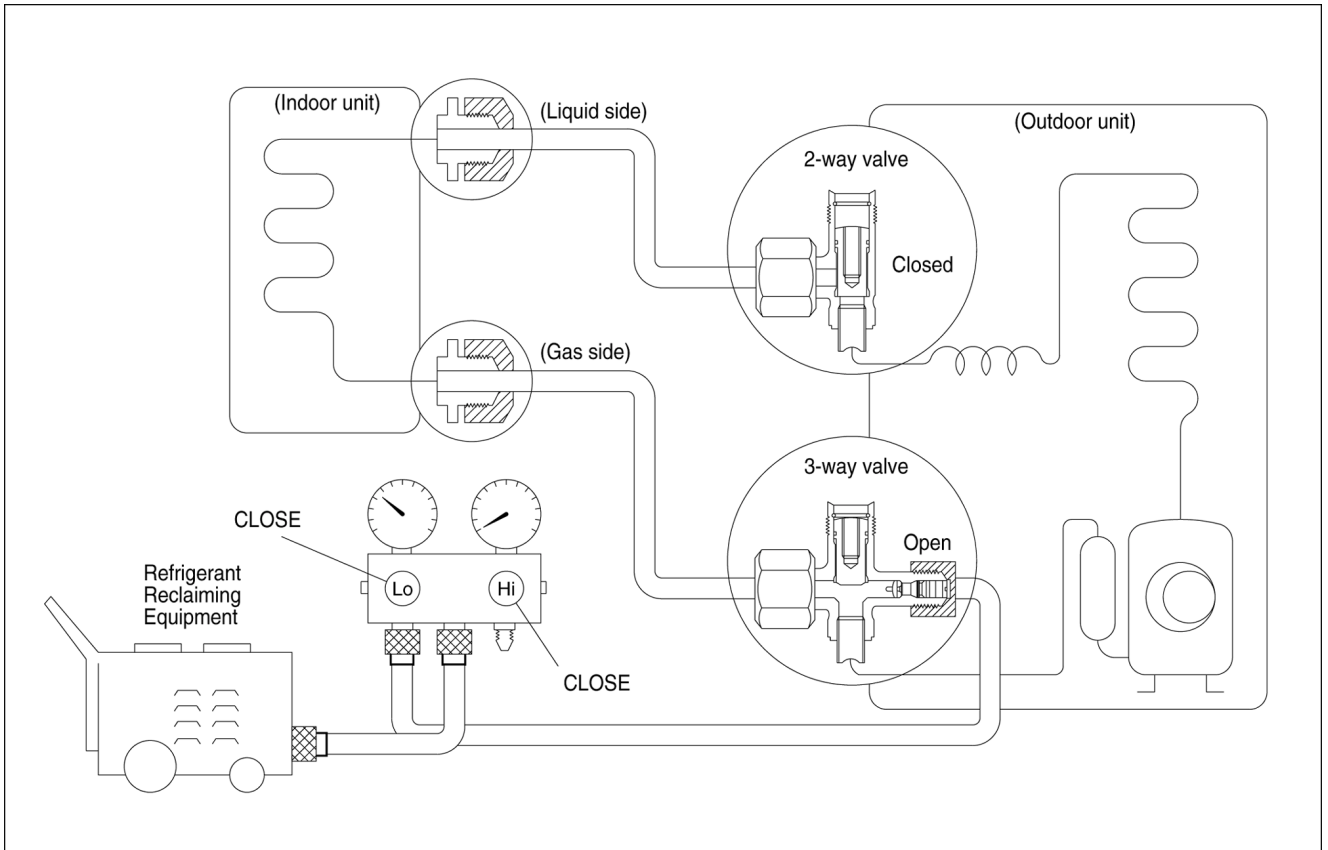

Procedure:

1. **Confirm that both the 2-way and 3-way valves are set to the opened position.**
 - Remove the valve stem caps and confirm that the valve stems are in the opened position.
 - Be sure to use a hexagonal wrench to operate the valve stems.
2. **Operate the unit for 10 to 15 minutes.**
3. **Stop operation and wait for 3 minutes, then connect the charge set to the service port of the 3-way valve.**
 - Connect the charge hose with the push pin to the Gas service port.
4. **Air purging of the charge hose.**
 - Open the low-pressure valve on the charge set slightly to purge air from the charge hose.
5. **Set the 2-way valve to the closed position.**
6. **Operate the air conditioner at the cooling cycle and stop it when the gauge indicates 0 MPa (0 kg/cm²G).**
If the unit cannot be operated at the cooling condition (weather is rather cool), short the Pumping Down pins on the Main Control P.C.B.
(Simply press the pumping down button if it is equipped.)
So that the unit can be operated.
7. **Immediately set the 3-way valve to the closed position.**
 - Do this quickly so that the gauge ends up indicating 0.1 MPa (1 kg/cm²G) to 0.3 MPa (3 kg/cm²G).
8. **Use refrigerant reclaiming equipment to collect refrigerant from indoor unit and pipes.**
9. **Disconnect the charge set, and mount the 2-way and 3-way valve's stem caps and the service port caps.**
 - Use a torque wrench to tighten the service port cap to a torque of 18 N.m.
 - Be sure to check for gas leakage.
10. **Disconnect pipes from indoor unit and outdoor unit.**

12.3. Evacuation of Re-installation

WHEN REINSTALLING AN AIR CONDITIONER, BE SURE TO EVACUATE THE AIR INSIDE THE INDOOR UNIT AND PIPES in the following procedure.

If air remain in the indoor unit and refrigeration pipes, it will affect the compressor, reduce to cooling capacity, and could lead to a malfunction.

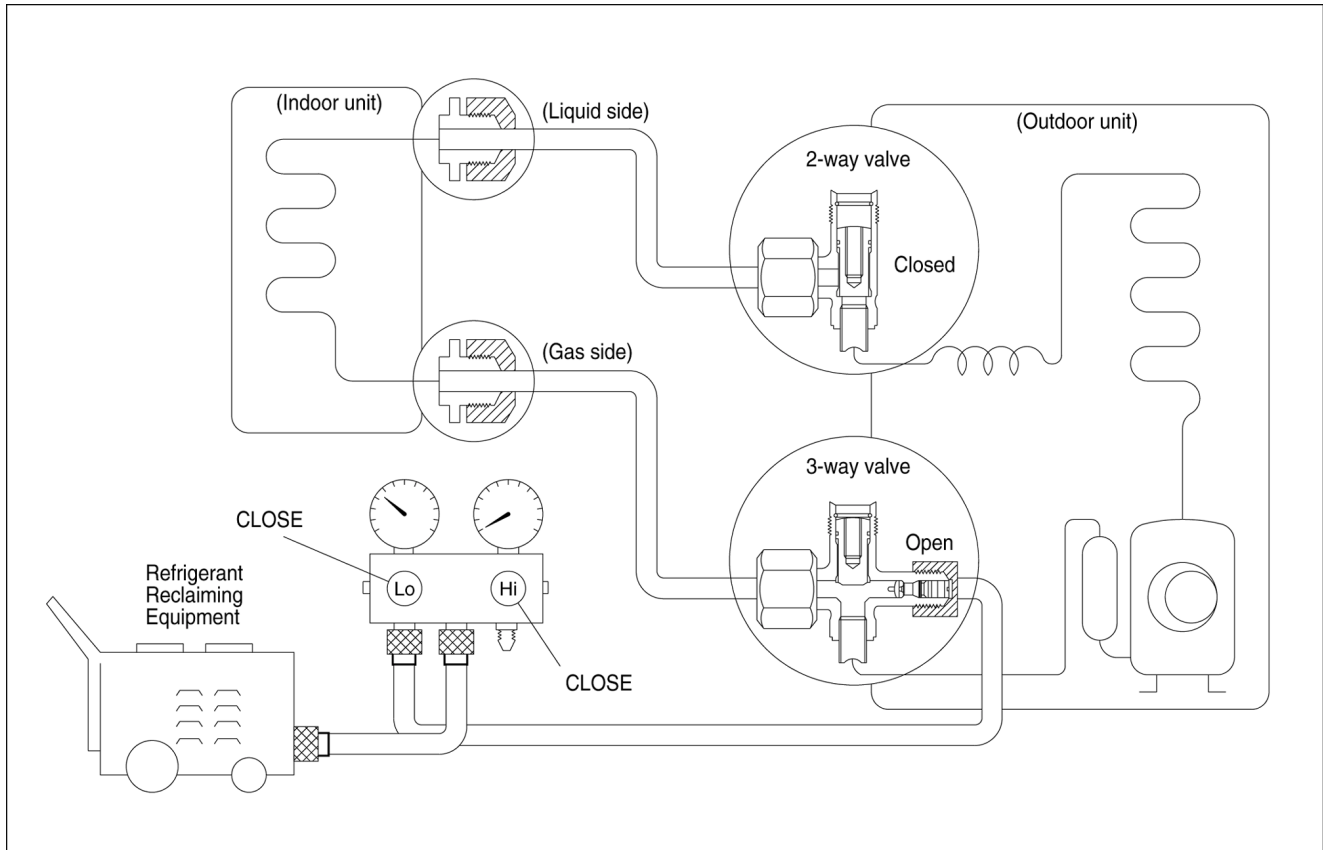

Procedure:

1. Connect a charging hose with a push pin to the Low side of a charging set and the service port of the 3-way valve.
 - Be sure to connect the end of the charging hose with the push pin to the service port.
2. Connect the centre hose of the charging set to a vacuum pump.
3. Turn on the power switch of the vacuum pump and make sure that the needle in the gauge moves from 0 MPa (0 cmHg) to -0.1 MPa (-76 cmHg). Then evacuate the air for approximately ten minutes.
4. Close the Low side valve of the charging set and turn off the vacuum pump. Make sure that the needle in the gauge does not move after approximately five minutes. **BE SURE TO TAKE THIS PROCEDURE IN ORDER TO AVOID GAS LEAKAGE.**
5. Disconnect the charging hose from the vacuum pump.
6. Charge the pipes and indoor unit with gas refrigerant from 3-way valve service port, and then discharge the refrigerant until low side (gas side) gauge needle indicates 0.3 MPa (3 kg/cm²).
7. Tighten the service port cap at a torque of 18 N.m with a torque wrench.
8. Remove the valve caps of the 2-way valve and the 3-way valve. Position both of the valves to "open" using a hexagonal wrench (4 mm).
9. Mount the valve caps onto the 2-way and 3-way valves.
 - **BE SURE TO USE REFRIGERANT RECLAIMING EQUIPMENT WHILE DISCHARGING THE REFRIGERANT.**
 - Purge the air from charge set's centre hose.
 - Be sure to check for gas leakage.

Caution

If gauge needle does not move from 0 MPa (0 cmHg) to -0.1 MPa (-76 cmHg) in step (3) above, take the following measures:

If the leaks stop when the piping connections are tightened further, continue working from step 3.

If the leaks do not stop when the connections are retightened, repair the location of the leak.

12.4. Balance refrigerant of the 2-way, 3-way valves

(Lack of refrigerant in the refrigeration cycle)

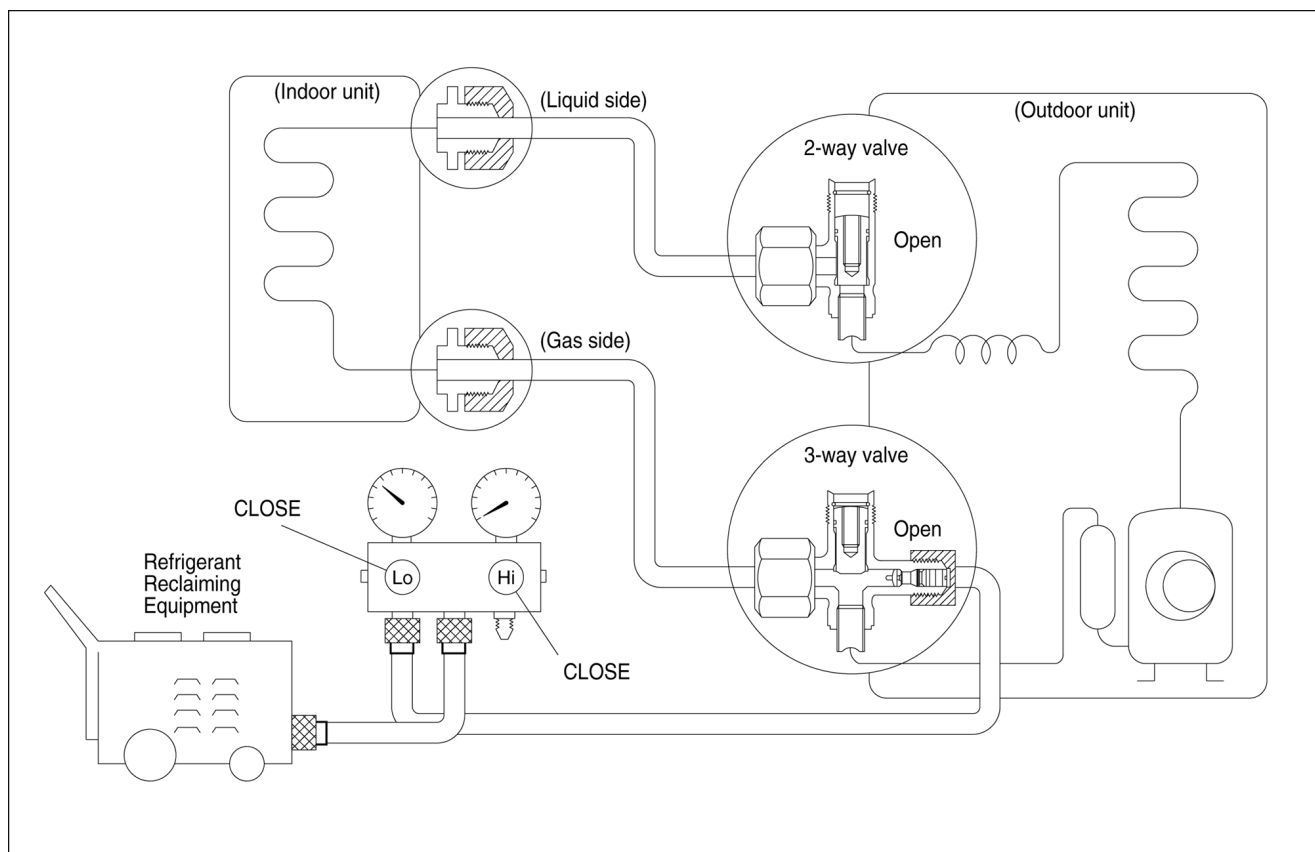

Procedure:

1. Confirm that both the 2-way and 3-way valves are set to the open position.
2. Connect the charge set to the 3-way valve's service port.
 - Leave the valve on the charge set closed.
 - Connect the charge hose with the push-pin to the service port.
3. Connect the charge set's centre hose to refrigerant reclaiming equipment.
 - Purge the air from charge hose.
4. Open the valve (Low side) on the charge set and discharge the refrigerant until the gauge indicates 0.05 MPa (0.5 kg/cm²G) to 0.1 MPa (1 kg/cm²G).
 - If there is no air in the refrigeration cycle (the pressure when the air conditioner is not running is higher than 0.1 MPa (1 kg/cm²G), discharge the refrigerant until the gauge indicates 0.05 MPa (0.5 km/cm²G) to 0.1 MPa (1 kg/cm²G). If this is the case, it will not be necessary to apply an evacuation.
 - Discharge the refrigerant gradually; if it is discharged too suddenly, the refrigeration oil will also be discharged.
5. Turn on refrigerant reclaiming equipment.

12.5. Evacuation

(No refrigerant in the refrigeration cycle)

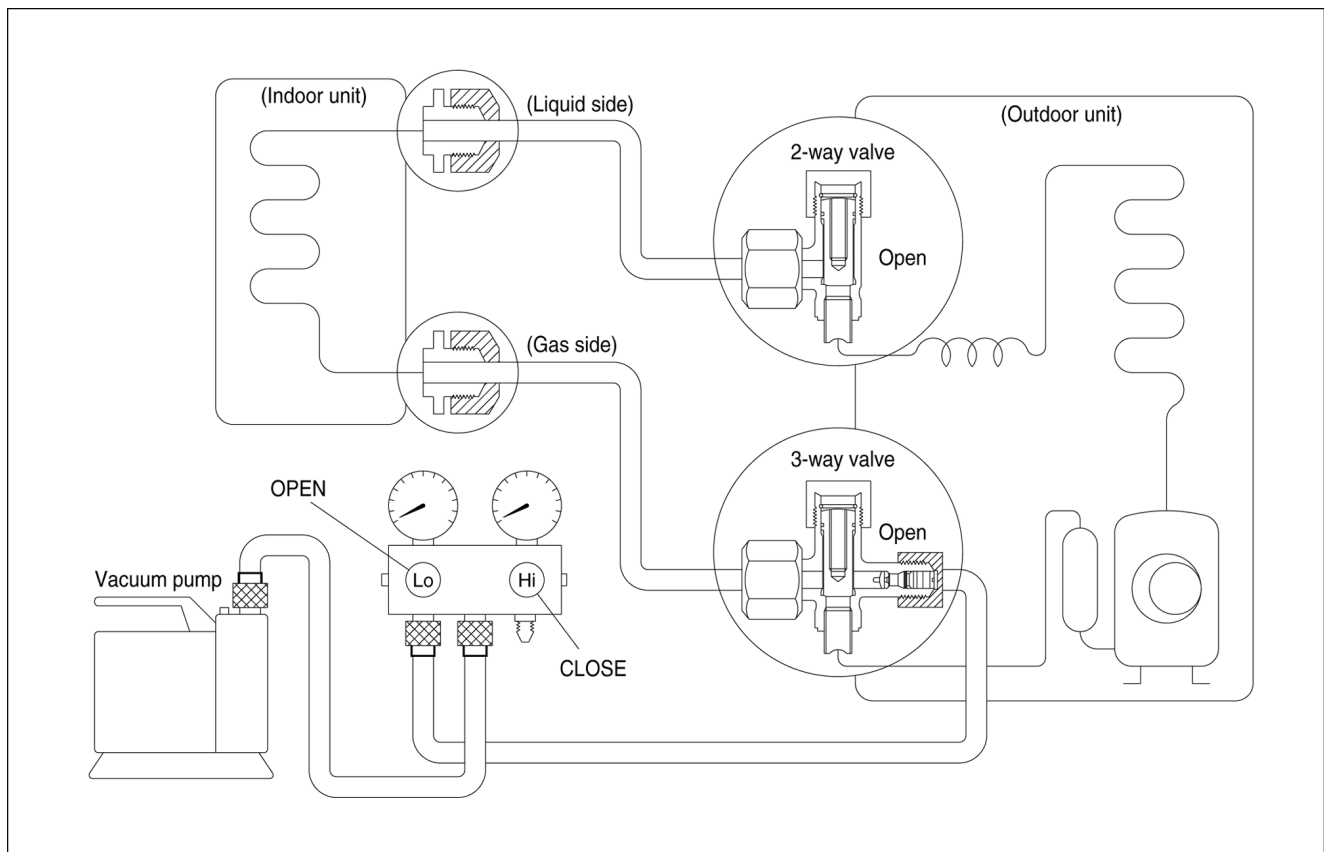

Procedure:

1. Connect the vacuum pump to the charge set's centre hose.
2. Evacuation for approximately one hour.
 - Confirm that the gauge needle has moved toward -0.1 MPa (-76 cmHg) [vacuum of 4 mmHg or less.]
3. Close the valve (Low side) on the charge set, turn off the vacuum pump, and confirm that the gauge needle does not move (approximately 5 minutes after turning off the vacuum pump).
4. Disconnect the charge hose from the vacuum pump.
 - Vacuum pump oil
 If the vacuum pump oil becomes dirty or depleted, replenish as needed.

12.6. Gas charging

(After Evacuation)

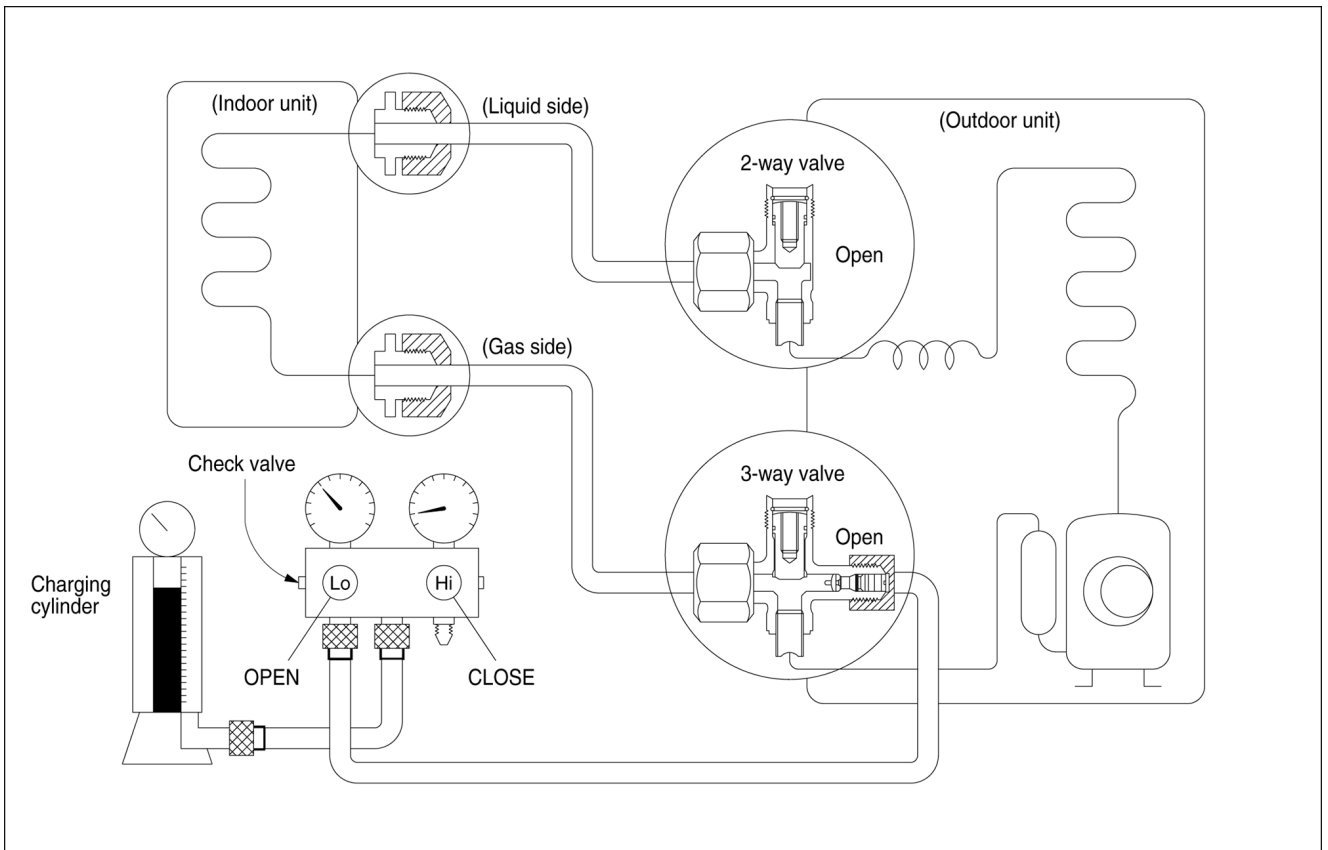

Procedure:

1. Connect the charge hose to the charging cylinder.

- Connect the charge hose which you disconnected from the vacuum pump to the valve at the bottom of the cylinder.

2. Purge the air from the charge hose.

- Open the valve at the bottom of the cylinder and press the check valve on the charge set to purge the air (be careful of the liquid refrigerant).

3. Open the valve (Low side) on the charge set and charge the system with liquid refrigerant.

- If the system cannot be charged with the specified amount of refrigerant, it can be charged with a little at a time (approximately 150 g each time) while operating the air conditioner in the cooling cycle; however, one time is not sufficient, wait approximately 1 minute and then repeat the procedure. (pumping down-pin)

This is different from previous procedures. Because you are charging with liquid refrigerant from the gas side, absolutely do no attempt to charge with large amount of liquid refrigerant while operating the air conditioner.

4. Immediately disconnect the charge hose from the 3-way valve's service port.

- Stopping partway will allow the refrigerant to be discharged.
- If the system has been charged with liquid refrigerant while operating the air conditioner, turn off the air conditioner before disconnecting the hose.

5. Mount the valve stem caps and the service port cap.

- Use torque wrench to tighten the service port cap to a torque of 18 N.m.
- Be sure to check for gas leakage.

13 Servicing Information

• Inspection points for the Indoor Electronic Controller

1. The Electronic Controller, a signal Receiver and an Indicator (Fig. 2) can be seen by the below steps:

- Remove the 2 caps and 2 screws at the bottom of the front grille. (Fig. 1)
- Remove the front grille by releasing the 2 hooks at the top of the front grille. (Fig. 1)
- Remove the control board cover by releasing the 2 tabs at left, 1 tab on top and 2 more tabs at right side of the control board cover. (Fig. 1)

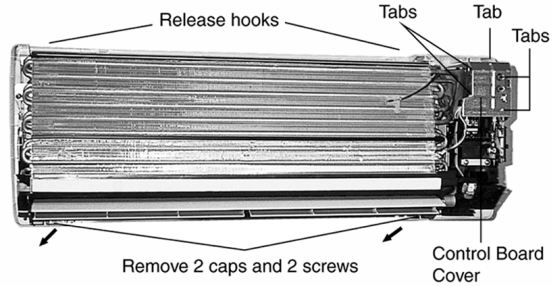

Fig. 1

2. To remove the Electronic Controller, release the hook that holding the electronic controller. (Fig. 2)

• Indoor Fan Motor removal procedure:-

1. Remove the control board by:-

- Releasing CN-C (GRN) connector. (Fig. 2)
- Releasing CN-FM (GRN) connector. (Fig. 2)
- Releasing CN-STM connector. (Fig. 2)
- Remove the earth wire screw. (Fig. 2)
- Release the intake air sensor. (Fig. 2)
- Release the piping sensor. (Fig. 2)

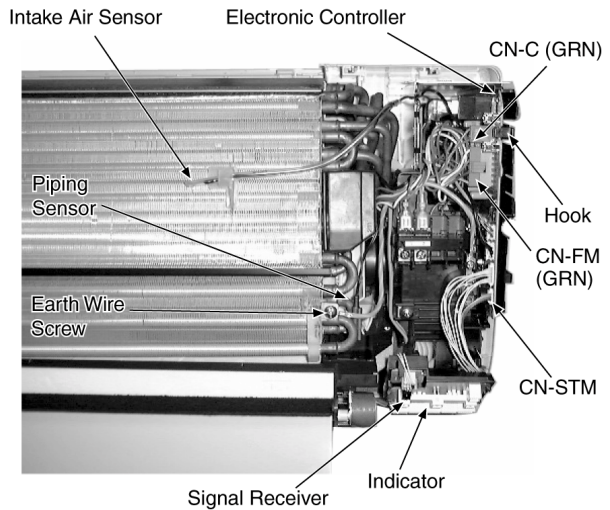

Fig. 2

- Remove the right and left screws. (Fig. 3)

- Then remove the control board by pressing down the hook at the left and press up the right hook. (Fig. 3)

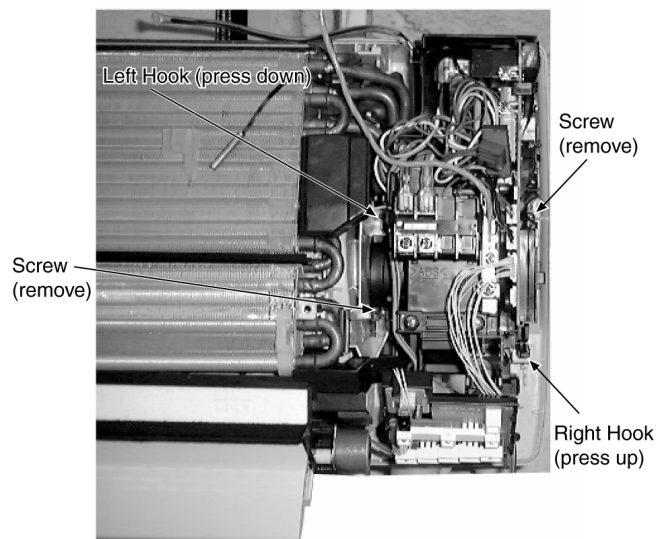

Fig. 3

2. Remove the Fan Motor by:-

- Release the Fan motor leadwire by pressing the hook at the center of the connector. (Fig. 4)
- Then remove the particular piece that holding the fan motor by pressing the tab. (Fig. 4)
- Remove the discharge grille and then the drain hose. (Fig. 4)

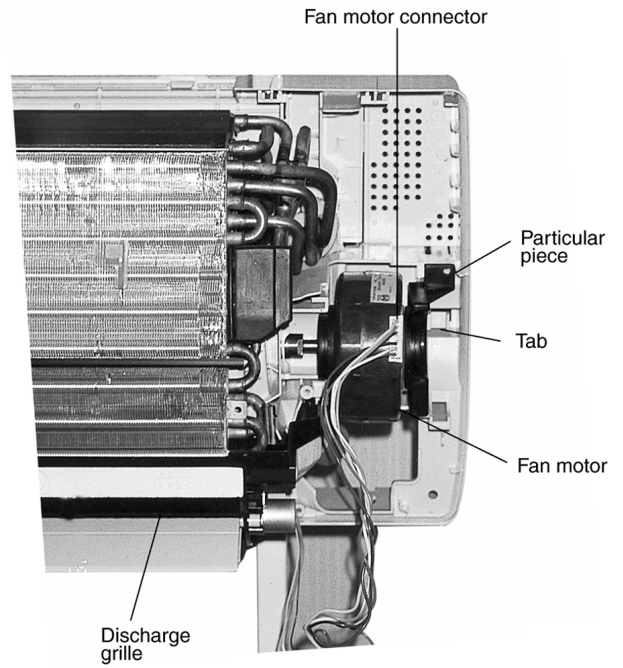

Fig. 4

- Finally remove the fan motor by removing the screw. (Fig. 5)
- REMINDER - To reinstall the fan motor, adjust the connector of the fan motor as Fig. 5.

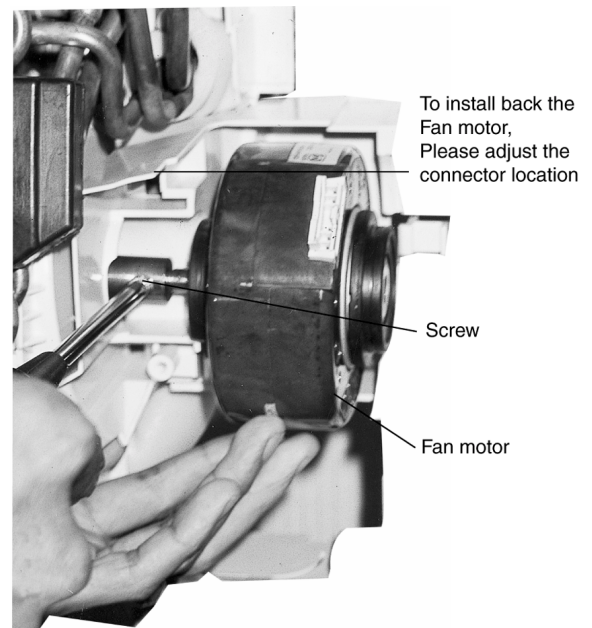

Fig. 5

• **Cross Flow Fan Removal Procedure.**

1. Remove the control board and the fan motor by referring to the "Indoor Fan Motor Removal Procedure".
2. Remove the evaporator screw. (Fig. 6)

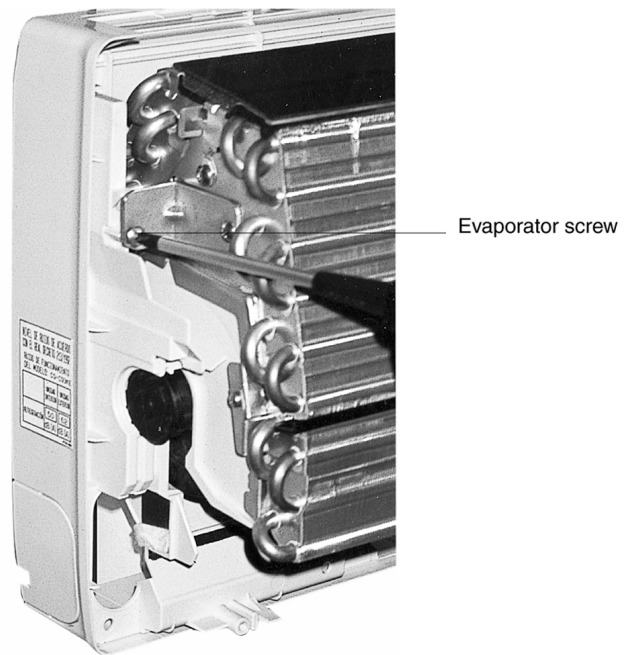

Fig. 6

3. Press the particular piece to loosen the evaporator. (Fig. 7)
4. Remove the bearing. (Fig. 7)
5. Push up the evaporator and take out the cross-flow Fan. (Fig. 7)

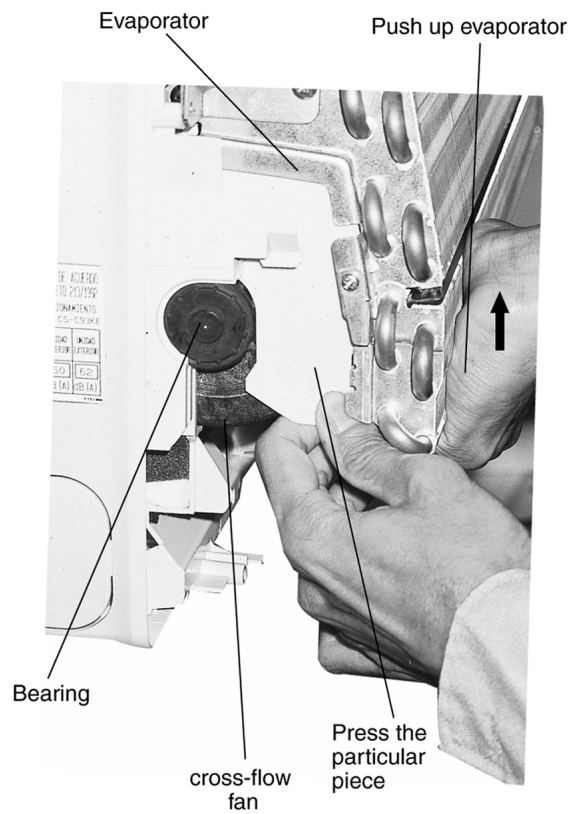
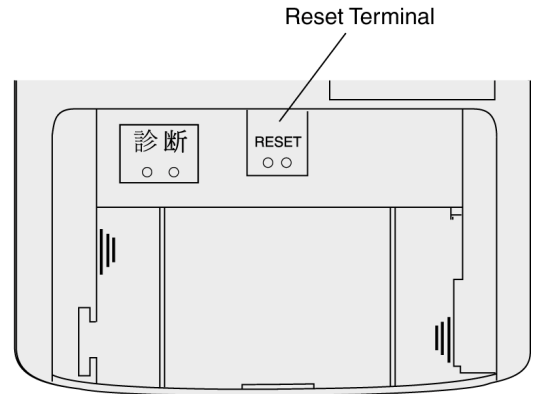

Fig. 7

• Remote Control Reset

When the batteries are inserted for the first time, or the batteries are replaced, all the indications will blink and the remote control might not work.

If this happen, remove the back cover of the remote control and you will find a resetting terminal, and by shorting it with a minus screwdriver, it will return to normal.



• Changing the wireless remote control transmission code

When two indoor units are installed in the same room, in order to prevent operating errors caused by using two remote controls, add a jumper wire to the remote control side (J-B) and a carbon resistor (1/4 W, 10kΩ) to the indoor printed circuit board (RX1), it is possible to select from 2 types of transmission codes including one at time of delivery condition (1).

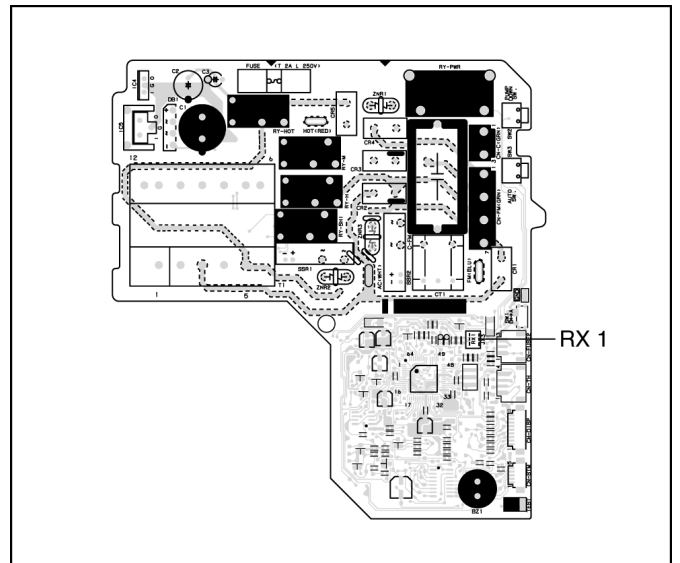

	Remote control		Indoor printed circuit board		Note
	SW2	J - B	SW1	RX1	
1	OPEN	—	OPEN	—	At product delivery
2	OPEN	Jumper wire	OPEN	10 kΩ	

NOTE: As of information in Electronic Circuit Diagram.

14 Troubleshooting Guide

14.1. Refrigeration cycle system

In order to diagnose malfunctions, make sure that there are no electrical problems before inspecting the refrigeration cycle. Such problems include insufficient insulation, problem with the power source, malfunction of a compressor and a fan.

The normal outlet air temperature and pressure of the refrigeration cycle depends on various conditions, the standard values for them are shown in the table to the right.

Normal Pressure and Outlet Air Temperature (Standard)

	Gas pressure Mpa (kg/cm ² G)	Outlet air temperature (°C)
Cooling Mode	0.9 ~ 1.2 (9 ~ 12)	12 ~ 16

* Condition: Indoor fan speed; High
Outdoor temperature 35°C

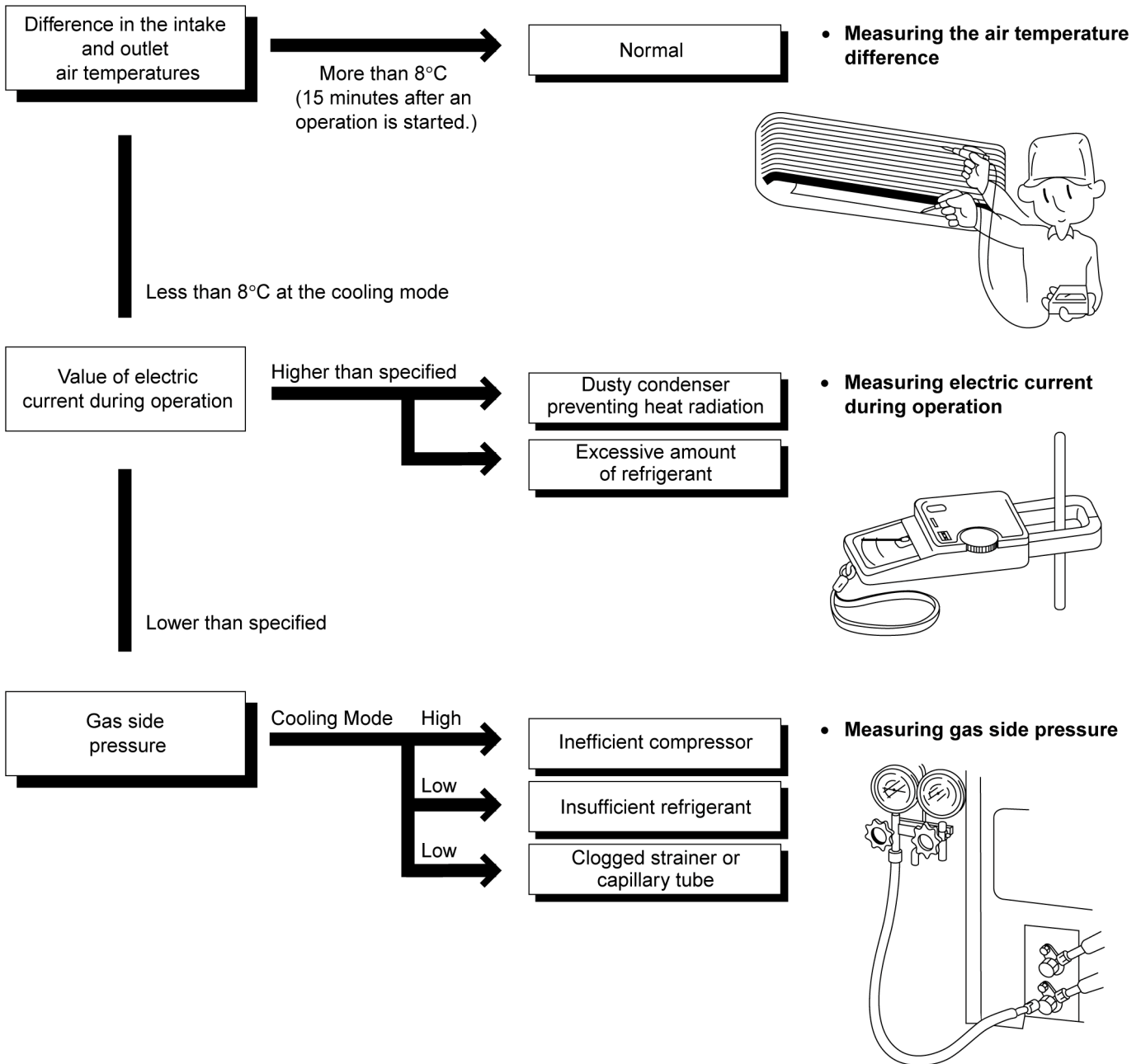

14.1.1. Relationship between the condition of the air conditioner and pressure and electric current

Condition of the air conditioner	Cooling Mode		
	Low Pressure	High Pressure	Electric current during operation
Insufficient refrigerant (gas leakage)	➔	➔	➔
Clogged capillary tube or Strainer	➔	➔	➔
Short circuit in the indoor unit	➔	➔	➔
Heat radiation deficiency of the outdoor unit	➔	➔	➔
Inefficient compression	➔	➔	➔

- Carry out the measurements of pressure, electric current, and temperature fifteen minutes after an operation is started.

14.1.2. Diagnosis methods of a malfunction of a compressor

Nature of fault	Symptom
Insufficient compressing of a compressor	<ul style="list-style-type: none"> • Electric current during operation becomes approximately 20% lower than the normal value. • The discharge tube of the compressor becomes abnormally hot (normally 70 to 90°C). • The difference between high pressure and low pressure becomes almost zero.
Locked compressor	<ul style="list-style-type: none"> • Electric current reaches a high level abnormally, and the value exceeds the limit of an ammeter. In some cases, a breaker turns off. • The compressor has a humming sound.

15 Technical Data

■ Thermostat characteristics

CS-VC75KE / CS-VC95KE / CS-VC125KE

• Cooling

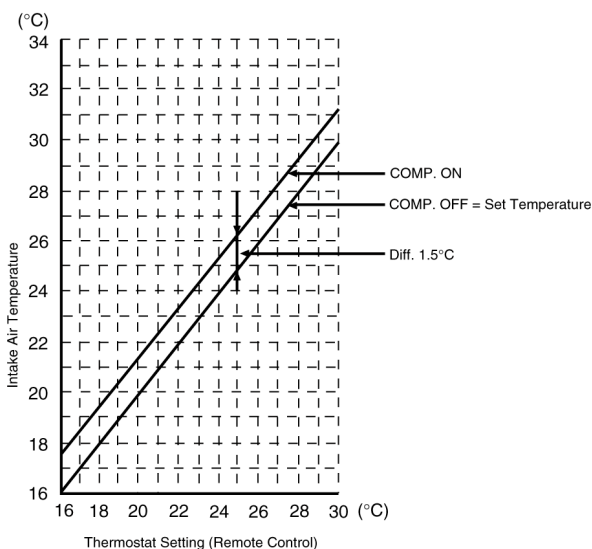

• Soft Dry

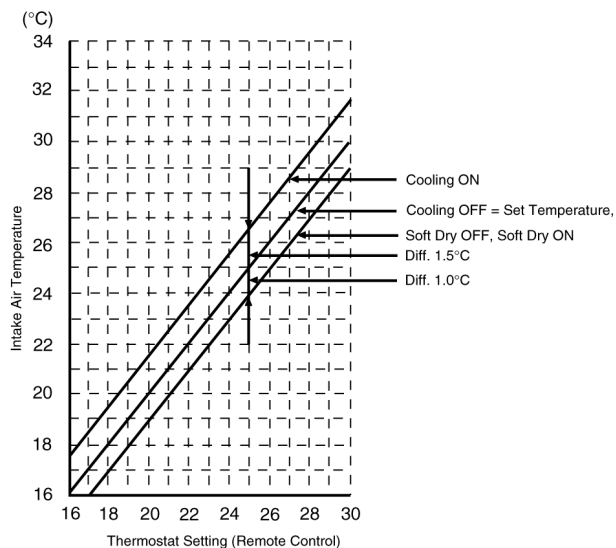

■ Sensible Capacity Chart

• CS-VC75KE

230V Indoor wet bulb temp.	Outdoor Temp. (°C)											
	30			35			40			46		
	TC	SHC	IP	TC	SHC	IP	TC	SHC	IP	TC	SHC	IP
17.0°C	2.10	1.59	0.57	1.97	1.53	0.61	1.83	1.47	0.65	1.66	1.40	0.70
19.0°C				2.12		0.62						
19.5°C	2.31	1.67	0.58	2.16	1.60	0.62	2.01	1.54	0.67	1.83	1.47	0.72
22.0°C	2.52	1.73	0.59	2.35	1.66	0.63	2.19	1.61	0.68	1.99	1.53	0.73

• CS-VC95KE

230V Indoor wet bulb temp.	Outdoor Temp. (°C)											
	30			35			40			46		
	TC	SHC	IP	TC	SHC	IP	TC	SHC	IP	TC	SHC	IP
17.0°C	2.73	2.07	0.75	2.55	1.98	0.81	2.37	1.91	0.86	2.16	1.81	0.93
19.0°C				2.75		0.82						
19.5°C	2.99	2.17	0.77	2.80	2.08	0.82	2.60	2.00	0.88	2.37	1.91	0.95
22.0°C	3.26	2.25	0.78	3.05	2.16	0.84	2.84	2.08	0.90	2.58	1.99	0.97

• CS-VC125KE

230V Indoor wet bulb temp.	Outdoor Temp. (°C)											
	30			35			40			46		
	TC	SHC	IP	TC	SHC	IP	TC	SHC	IP	TC	SHC	IP
17.0°C	3.62	2.74	1.15	3.38	2.63	1.24	3.15	2.53	1.33	2.86	2.40	1.43
19.0°C				3.65		1.26						
19.5°C	3.97	2.87	1.18	3.72	2.76	1.27	3.46	2.66	1.35	3.14	2.53	1.46
22.0°C	4.33	2.98	1.20	4.05	2.87	1.29	3.77	2.76	1.38	3.42	2.64	1.49

TC - Total Cooling (kW)
 SHC - Sensible Heat Capacity (kW)
 IP - Input Power (kw)

Indoor 27°C/19°C
 Outdoor 35°C/24°C

■ Operation characteristics

CS-VC75KE / CU-VC75KE

● Cooling Characteristic

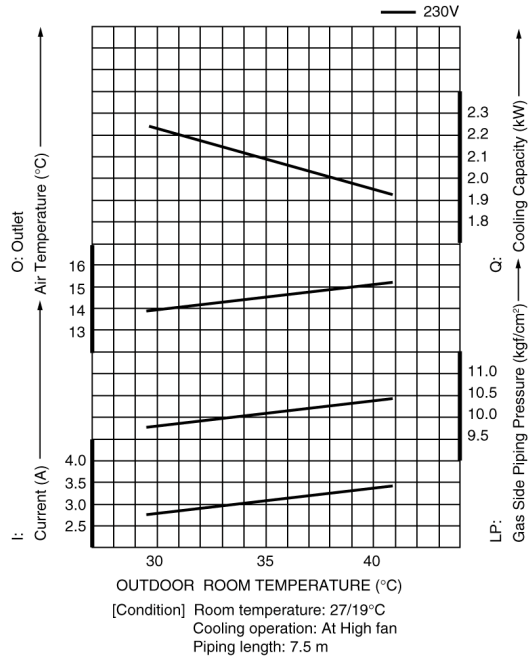

● Piping Length Characteristic

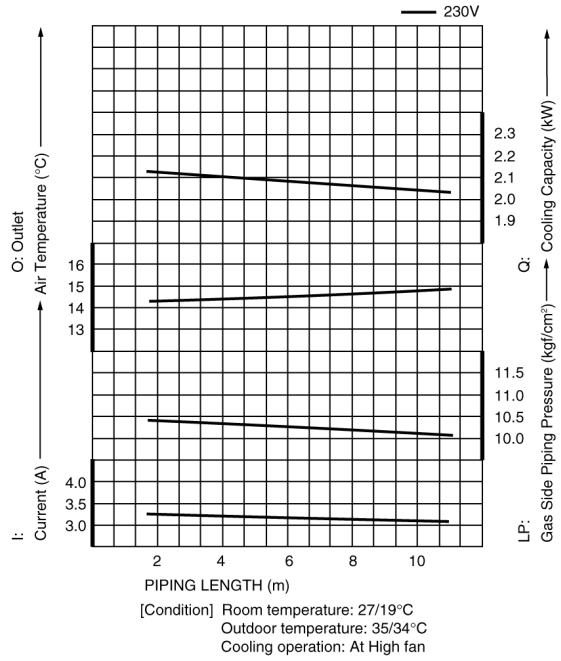

■ Operation characteristics

CS-VC95KE / CU-VC95KE

● Cooling Characteristic

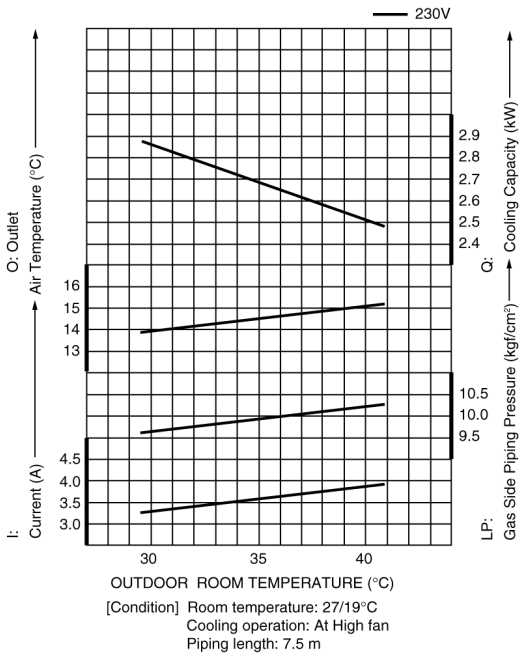

● Piping Length Characteristic

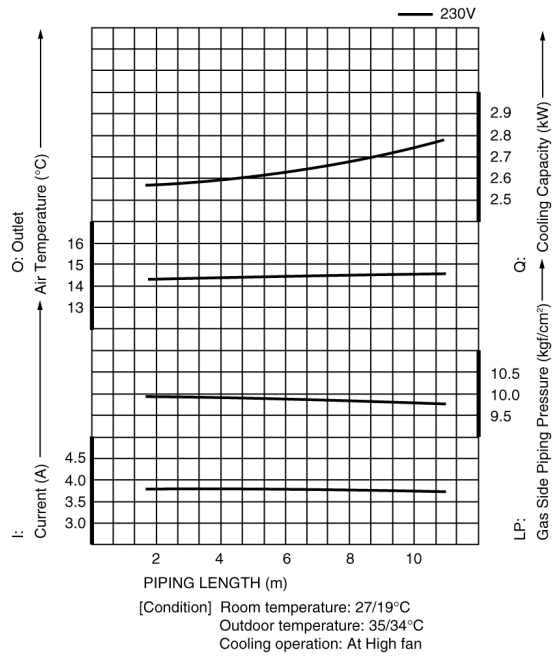

CS-VC125KE / CU-VC125KE

● Cooling Characteristic

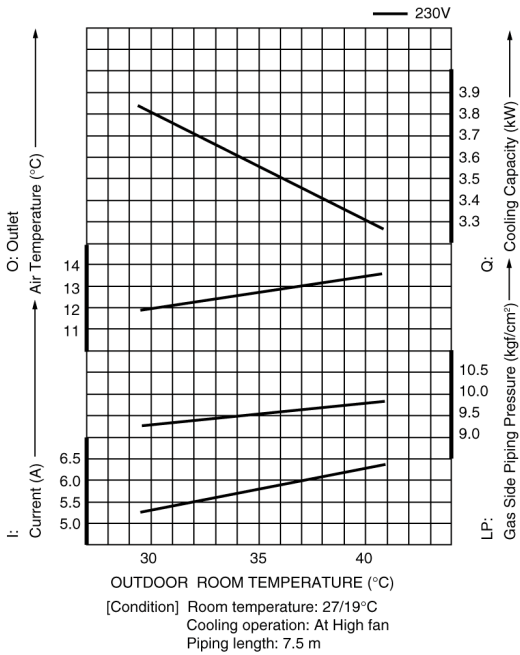

● Piping Length Characteristic

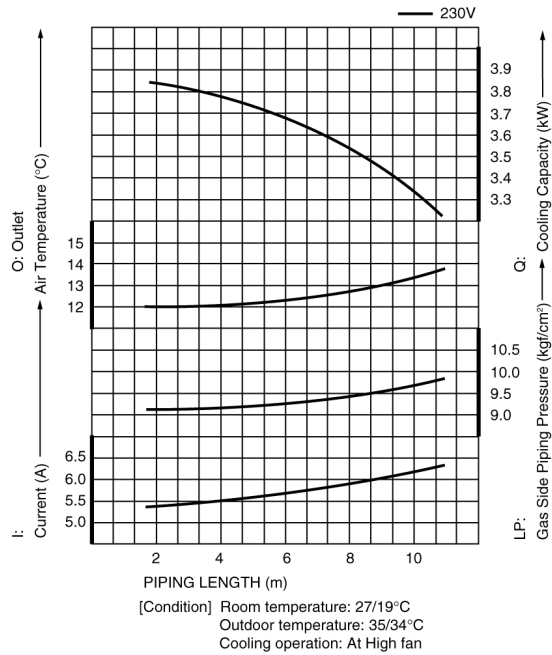

16 Exploded View

CS-VC75KE / CS-VC95KE / CS-VC125KE

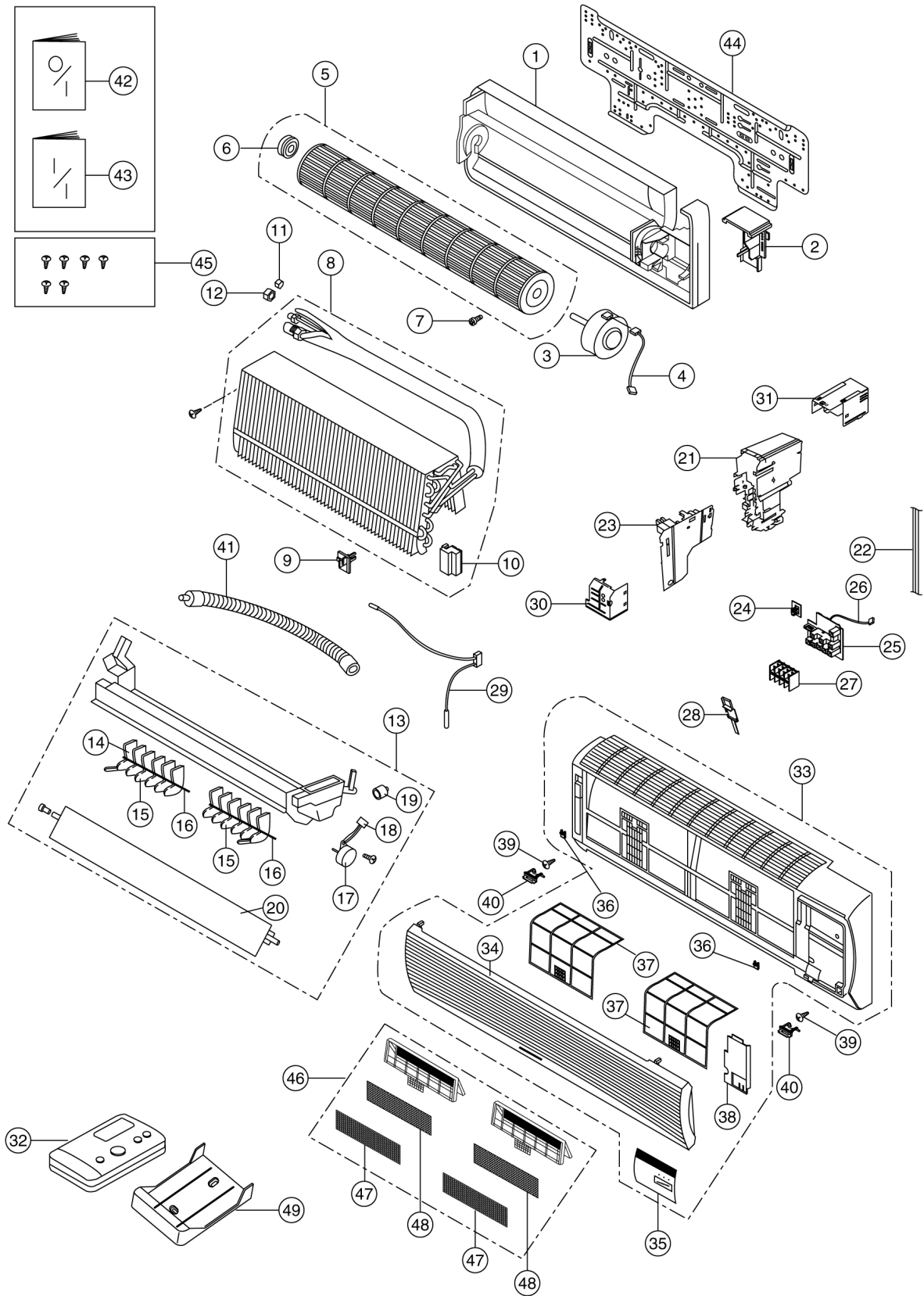

Note:

The above exploded view is for the purpose of parts disassembly and replacement.

The non-numbered parts are not kept as standard service parts.

17 Replacement Parts List

<Model: CS-VC75KE / CS-VC95KE / CS-VC125KE>

NO.	DESCRIPTION & NAME	Q'TY	CS-VC75KE	CS-VC95KE	CS-VC125KE	REMARKS
1	CHASSY COMPLETE	1	CWD50C338	←	←	
2	PARTICULAR PIECE	1	CWD931019	←	←	
3	FAN MOTOR	1	CWA921033	CWA921037	CWA921031	0
4	LEAD WIRE - FAN MOTOR	1	CWA67C2097	←	←	
5	CROSS FLOW FAN	1	CWH02C060	←	←	
6	BEARING	1	CWH64K007	←	←	
7	SCREW - CROSS FLOW FAN	1	CWH4580304	←	←	
8	EVAPORATOR & TUBE ASS'Y COMPLETE	1	CWB30C1050	CWB30C1051	CWB30C1052	
9	INTAKE AIR SENSOR HOLDER	1	CWH32142	←	←	
10	ANTI VIBRATION BUSHING	1	-	CWH50211	←	
11	FLARE NUT (1/4")	1	CWH6002140(1/4")	←	←	
12	FLARE NUT (3/8")	1	CWT25005 (3/8")	←	CWT25007 (1/2")	
13	DISCHARGE GRILLE COMPLETE	1	CWE20C2062	←	CWE20C2061	
14	VERTICAL VANE WITH TAB	2	CWE24458	←	←	
15	VERTICAL VANE	10	CWE24457	←	←	
16	CONNECTING BAR	2	CWE26194	←	←	
17	AIR SWING MOTOR	1	CWA98259	←	CWA98C033	0
18	LEAD WIRE - AIR SWING MOTOR	1	CWA67C2106	←	←	
19	CAP FOR DRAIN TRAY	1	CWH52C003	←	←	
20	HORIZONTAL VANE	1	CWE241027	←	←	
21	CONTROL BOARD	1	CWH10965	←	←	
22	POWER SUPPLY CORD	1	CWA20C2102	←	←	
23	ELECTRONIC CONTROLLER	1	CWA742323	←	←	0
24	RECEIVER	1	CWA74919	←	←	0
25	INDICATOR COMPLETE	1	CWE39C1024	←	←	
26	LEAD WIRE - INDICATOR	1	CWA67C2105	←	←	0
27	TERMINAL BOARD	1	CWA28C2028	←	CWA28C2027	0
28	INDICATOR HOLDER	1	CWD931018	←	←	
29	TEMPERATURE SENSOR	1	CWA50C608	←	←	0
30	CONTROL BOARD FRONT COVER	1	CWH13456	←	←	
31	CONTROL BOARD TOP COVER	1	CWH13457	←	←	
32	REMOTE CONTROL COMPLETE	1	CWA75C2079	←	←	0
33	FRONT GRILLE COMPLETE	1	CWE11C2106	←	←	
34	INTAKE GRILLE COMPLETE	1	CWE22C1006	←	←	
35	DECORATION BASE COMPLETE	1	CWE35C1007	←	←	
36	TAB	2	CWD931020	←	←	
37	AIR FILTER	2	CWD00240	←	←	
38	GRILLE DOOR	1	CWE141013	←	←	
39	SCREW FOR FRONT GRILLE	2	XTN4+16C	←	←	
40	CAP FOR FRONT GRILLE	2	CWH52267	←	←	
41	DRAIN HOSE	1	CWH5880580	←	←	
42	OPERATING INSTRUCTIONS	1	CWF563162	←	←	
43	INSTALLATION INSTRUCTIONS	1	CWF612088	←	CWF612089	
44	INSTALLATION PLATE	1	CWH36157	←	←	
45	BAG COMPLETE - INSTALLATION SCREW	1	CWH82C1054	←	←	
46	AIR PURIFYING FILTER COMPLETE	1	CWD00C1028	←	←	
47	AIR PURIFYING FILTER (CATECHIN)	2	CWD001014	←	←	0
48	AIR PURIFYING FILTER (DEODORIZING)	2	CWD001033	←	←	0
49	REMOTE CONTROL HOLDER	1	CWH36161	←	←	

(Note)

- All parts are supplied from MACC, Malaysia (Vendor Code: 086).
- "O" marked parts are recommended to be kept in stock.

18 Exploded View

CU-VC75KE / CU-VC95KE

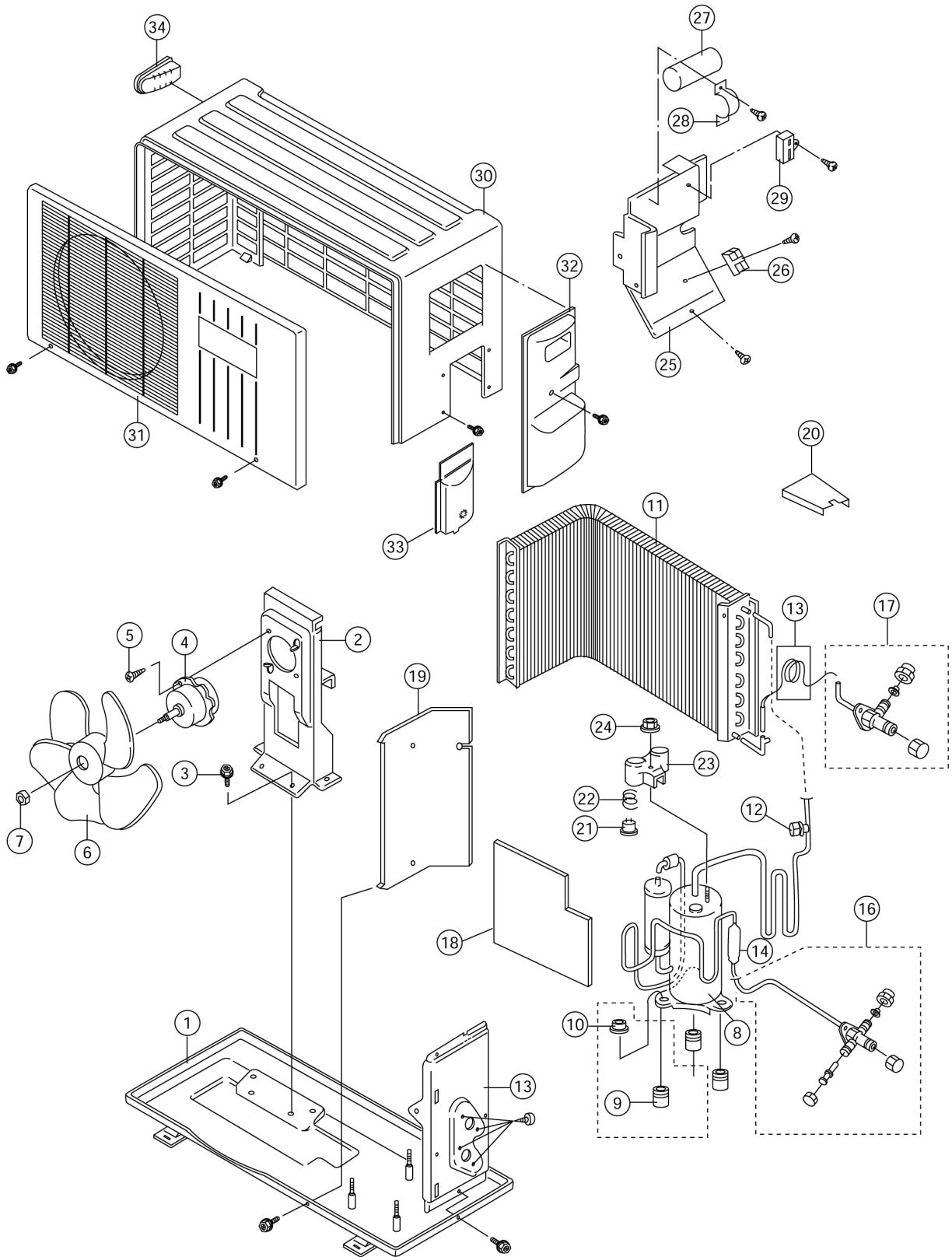

Note:

The above exploded view is for the purpose of parts disassembly and replacement.

The non-numbered parts are not kept as standard service parts.

19 Replacement Parts List

<Model: CU-VC75KE / CU-VC95KE>

NO.	DESCRIPTION & NAME	Q'TY	CU-VC75KE	CU-VC95KE	REMARKS
1	CHASSY ASS'Y	1	CWD50K2035A	←	
2	FAN MOTOR BRACKET	1	CWD54113	←	
3	SCREW - FAN MOTOR BRACKET	4	CWH4580399	←	
4	FAN MOTOR	1	CWA951040	←	0
5	SCREW - FAN MOTOR MOUNT	3	CWH55027	←	
6	PROPELLER FAN	1	CWH00K052	←	
7	NUT - PROPELLER FAN	1	CWH56032	←	
8	COMPRESSOR	1	5RS080DAA	5PS102DAA	0
9	ANTI - VIBRATION BUSHING	3	CWH50077	←	
10	NUT - COMPRESSOR MOUNT	3	CWH56000	←	
11	CONDENSER	1	CWB32C1075	←	
12	CHECK VALVE COMPLETE	1	CWB03C1001	←	
13	TUBE ASS'Y (CAPILLARY TUBE)	1	CWT01C2158	CWT01C2159	
14	DRYER	1	CWB101005	←	
15	HOLDER COUPLING ASS'Y	1	CWH351011	←	
16	3-WAY VALVE	1	CWB011029	←	0
17	2-WAY VALVE	1	CWB021030	←	0
18	SOUND PROOF MATERIAL	1	CWG302050	CWG302069	
19	SOUND PROOF BOARD	1	CWH15266	←	
20	L - SHAPED PLATE	1	CWD60247	←	
21	OVERLOAD PROPECTOR	1	CWA12304	CWA12344	0
22	HOLDER - O.L.P.	1	CWH7041200	←	0
23	TERMINAL COVER	1	CWH171011	←	
24	NUT - TERMINAL COVER	1	CWH7080300	←	
25	CONTROL BOARD	1	CWH102081	←	
26	TERMINAL BOARD ASS'Y	1	CWA28K217	←	
27	CAPACITOR - COMPRESSOR	1	CWA31653 (20 μ F, 370V)	CWA31647 (30 μ F, 370V)	0
28	HOLDER CAPACITOR	1	CWH30057	←	0
29	CAPACITOR FAN MOTOR	1	CWA31602 (1.2 μ F, 400V)	←	
30	CABINET ASS'Y	1	CWE00K1019A	←	
31	CABINET FRONT PLATE	1	CWE06C117A	←	
32	CONTROL BOARD COVER	1	CWH131062	←	
33	PLATE FOR CONTROL BOARD COVER	1	CWD911083	←	
34	HANDLE	1	CWE16037C	←	

(Note)

- All parts are supplied from MACC, Malaysia (Vendor Code: 086).
- "O" marked parts are recommended to be kept in stock.

20 Exploded View

CU-VC125KE

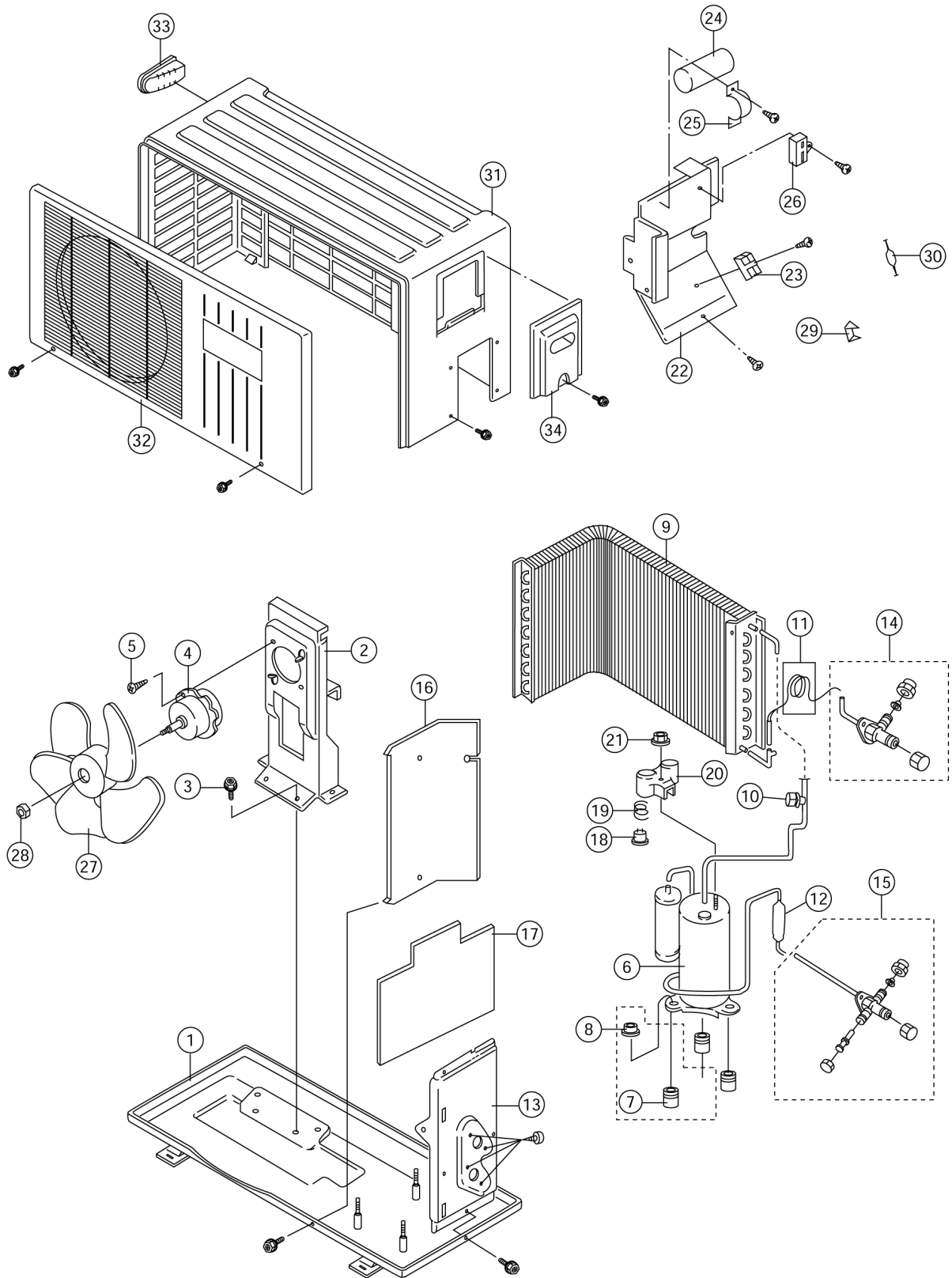

Note:

The above exploded view is for the purpose of parts disassembly and replacement.
 The non-numbered parts are not kept as standard service parts.

21 Replacement Parts List

<Model: CU-VC125KE>

NO.	DESCRIPTION & NAME	Q'TY	CU-VC125KE	REMARKS
1	CHASSY ASS'Y	1	CWD50K2010B	
2	FAN MOTOR BRACKET	1	CWD54171	
3	SCREW - FAN MOTOR BRACKET	4	CWH4580399	
4	FAN MOTOR	1	CWA95319	0
5	SCREW - FAN MOTOR MOUNT	3	CWH55027	
6	COMPRESSOR	1	5KS150DAA	0
7	ANTI - VIBRATION BUSHING	3	CWH50055	
8	NUT - COMPRESSOR MOUNT	3	CWH4582065	
9	CONDENSER	1	CWB32C1078	
10	CHECK VALVE COMPLETE	1	CWB03C1002	
11	TUBE ASS'Y (STRAINER CAPILLARY)	1	CWT01C2160	
12	DRYER	1	CWB101005	
13	HOLDER COUPLING ASS'Y	1	CWH35K019A	
14	2-WAY VALVE	1	CWB021031	0
15	3-WAY VALVE	1	CWB011030	0
16	SOUND PROOF BOARD	1	CWH15265	
17	SOUND PROOF MATERIAL	1	CWG302069	
18	OVERLOAD PROTECTOR	1	CWA12364	0
19	HOLDER - O.L.P.	1	CWH7041200	
20	TERMINAL COVER	1	CWH171011	
21	NUT - TERMINAL COVER	1	CWH7080300	
22	CONTROL BOARD	1	CWH10878	
23	TERMINAL BOARD ASS'Y	1	CWA28K217	
24	CAPACITOR - COMPRESSOR	1	CWA31647 (30 μ F , 370V)	0
25	HOLDER CAPACITOR	1	CWH30057	
26	CAPACITOR - FAN MOTOR	1	CWA31602 (1.2 μ F , 400V)	0
27	PROPELLER FAN ASS'Y	1	CWH00K040	
28	NUT - PROPELLER FAN	1	CWH56032	
29	FUSE HOLDER	1	XCSCW011	
30	FUSE	1	XBA2C50TR0	
31	CABINET ASS'Y	1	CWE00K302A	
32	CABINET FRONT PLATE	1	CWE06C1026A	
33	HANDLE	1	CWE16037C	
34	CONTROL BOARD COVER	1	CWH13302	

(Note)

- All parts are supplied from MACC, Malaysia (Vendor Code: 086).
- "O" marked parts are recommended to be kept in stock.

22 Electronic Parts List

<Electronic Controller Part No.: CWA742323>

SYMBOL	DESCRIPTION & NAME	PART NO.
BZ1	SOUND GENERATOR	A48040
D1, D4	DIODE	A541SR154-4
DB1	DIODE	A54CS1VB20E
FUSE	FUSE	XBA2C20TR0
IC1	INTEGRATED CIRCUIT	A52D0022GB14
IC2	INTEGRATED CIRCUIT	A52BR9020F
IC3	INTEGRATED CIRCUIT	A52A2003GR2
IC4	INTEGRATED CIRCUIT	A52C040
IC5	INTEGRATED CIRCUIT	A52C114
Q1	TRANSISTOR	A55DC114EKT
Q2, Q3	TRANSISTOR	A55C2412KTX
Q4	TRANSISTOR	A55D1484K
Q5 - Q8	TRANSISTOR	A55DC143XKTX
RY-PWR	ELECTRO MAGNETIC RELAY	A001001
RY-SHi, RY-Hi, RY-M	ELECTRO MAGNETIC RELAY	A00160
SSR1, SSR2	TYRISTOR	A56G3MC202PL
SW3	PUSH SWITCH	A01059
T1	TRANSFORMER	A401022
X1	RESONATOR	A45CST4.09MG
ZD1	DIODE	A54D7.5MT1B
ZNR1, ZNR2, ZNR3	DIODE	ERZVEAV511
C-FM	SH CAPACITOR	A31698
CR1, CR2, CR3, CR4, CR5	SURGE ABSORBER	A59014

Note

- All parts are supplied from MACC, Malaysia (Vendor Code: 086)

23 Electronic Circuit Diagram

- CS-VC75KE / CU-VC75KE
- CS-VC95KE / CU-VC95KE
- CS-VC125KE / CU-VC125KE

SCHEMATIC DIAGRAM 1/3

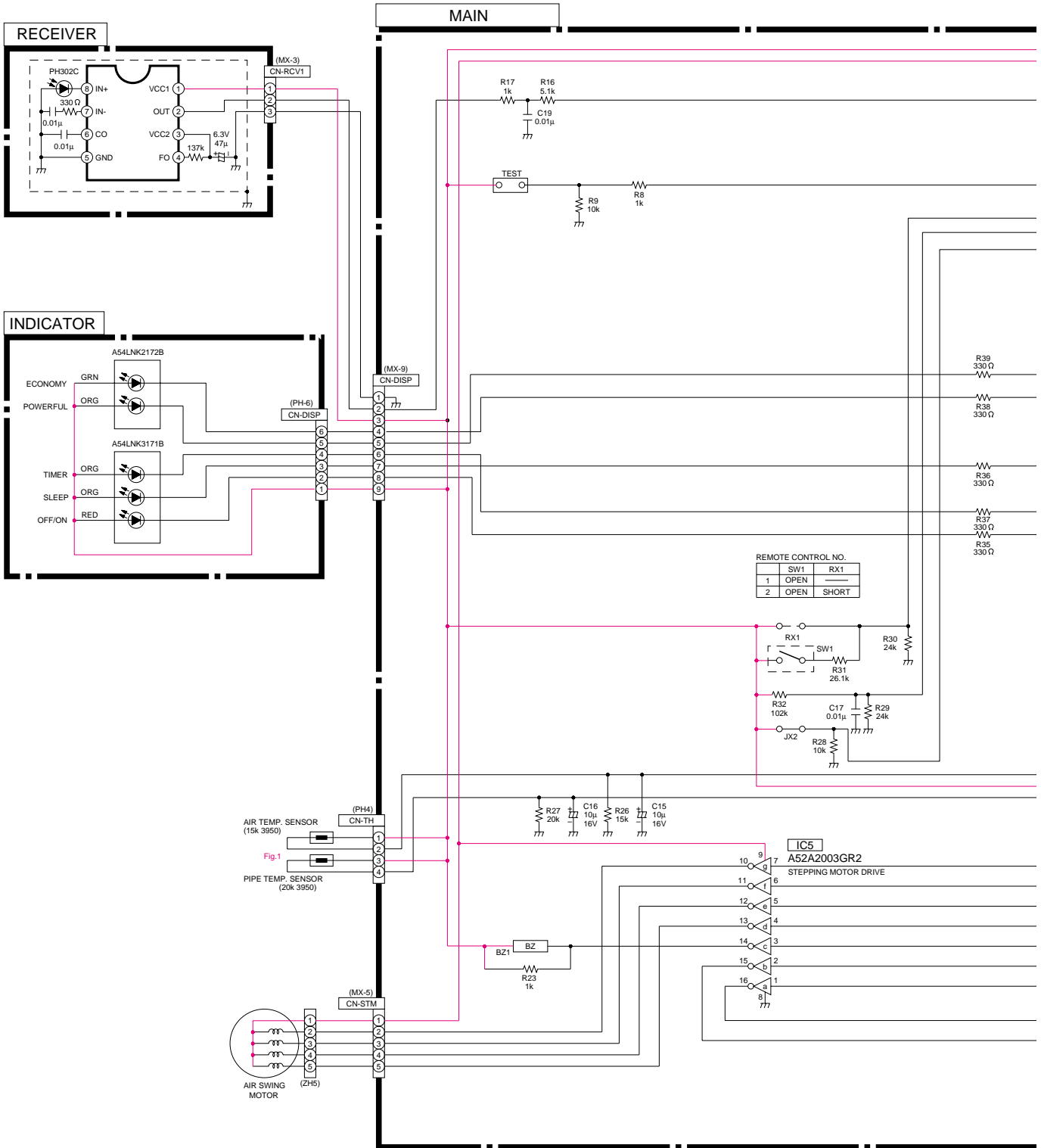

SCHEMATIC DIAGRAM 2/3

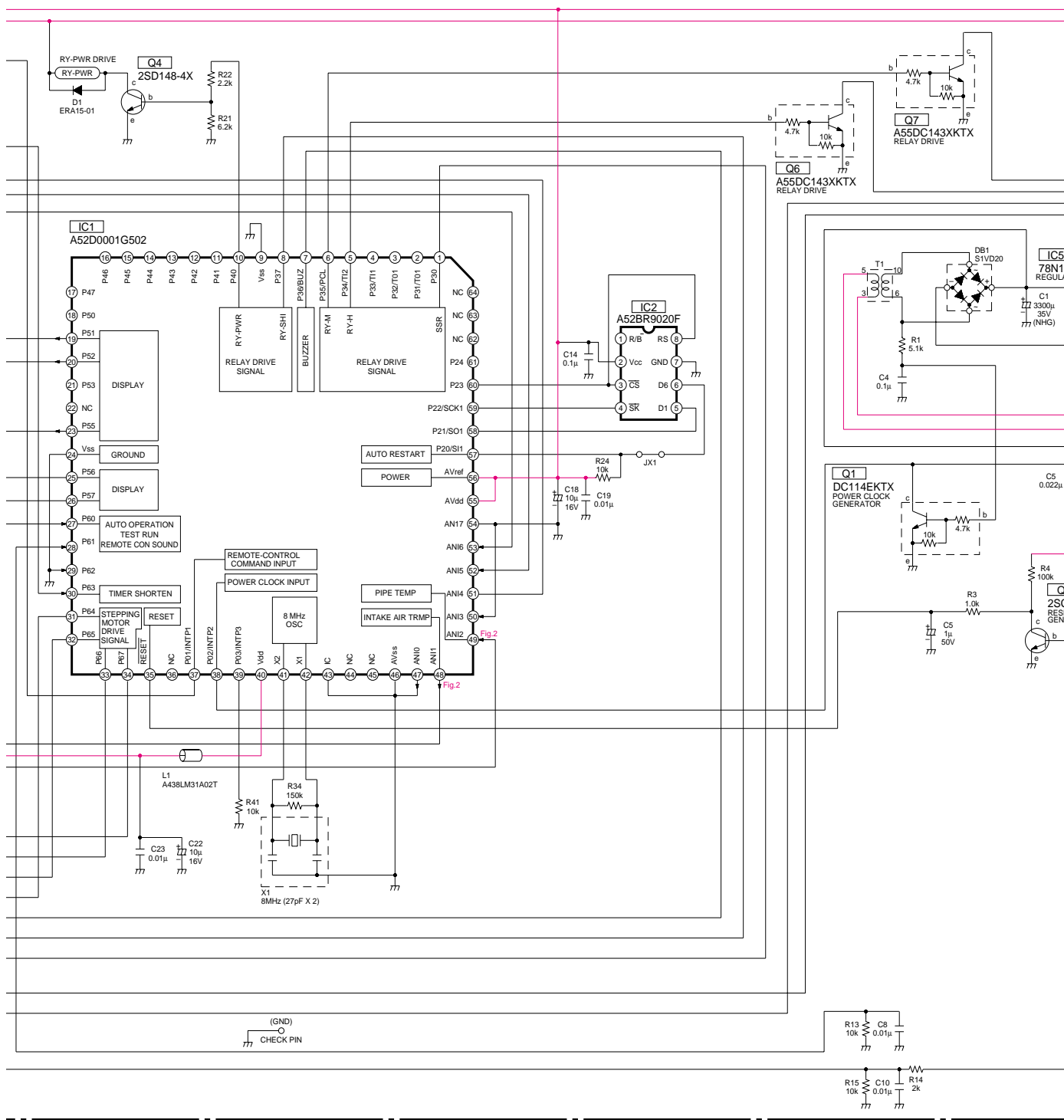

SCHEMATIC DIAGRAM 3/3

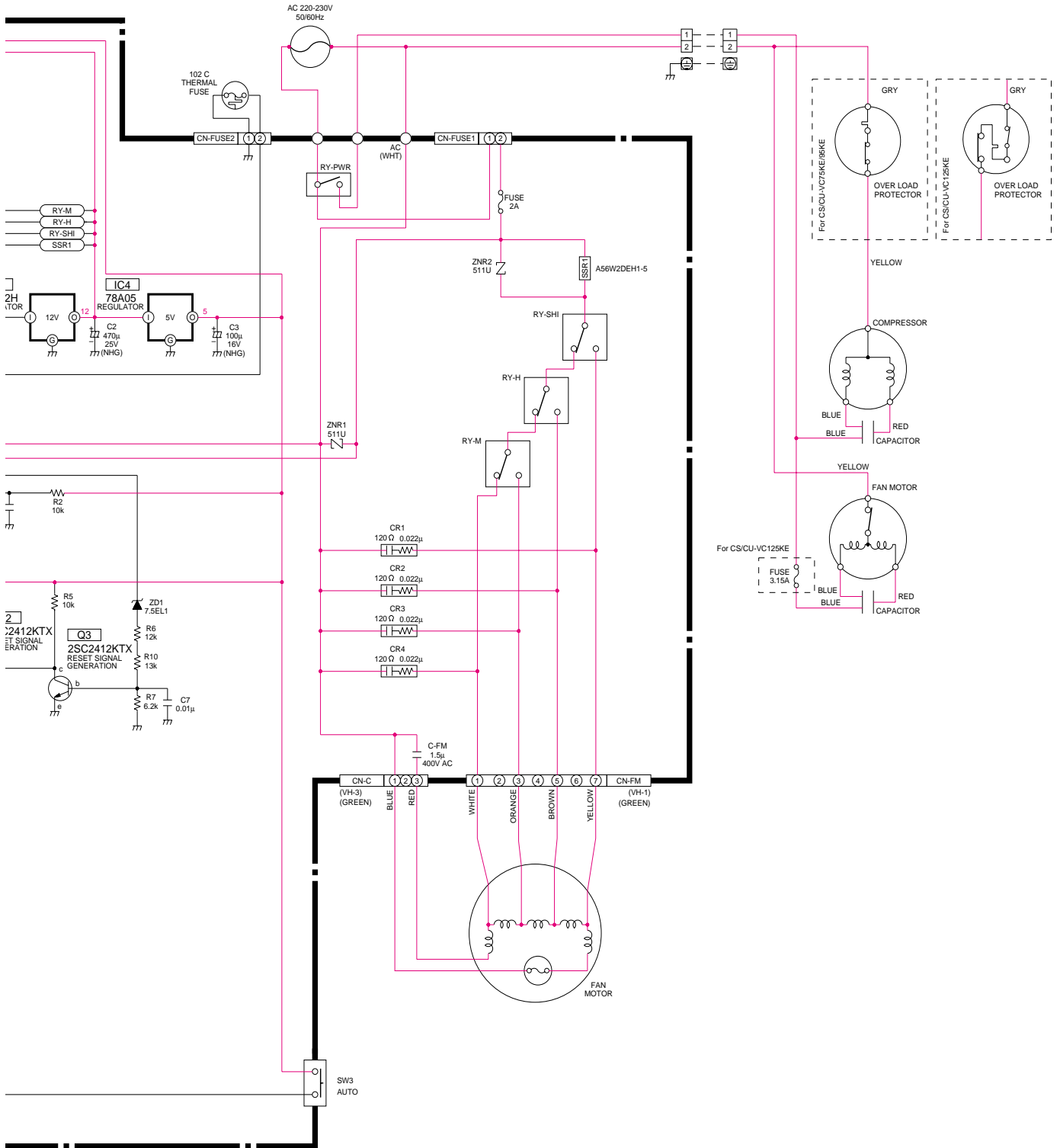

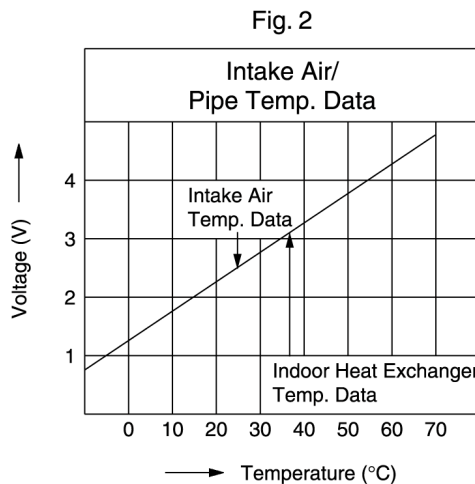
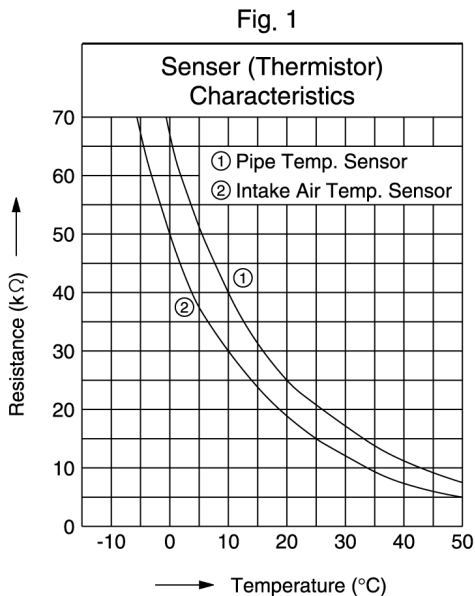
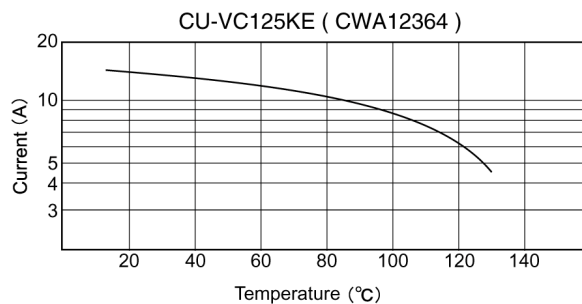
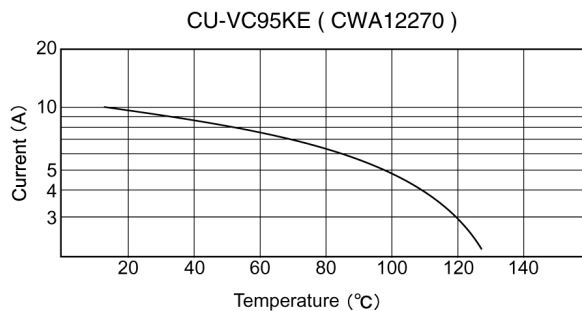
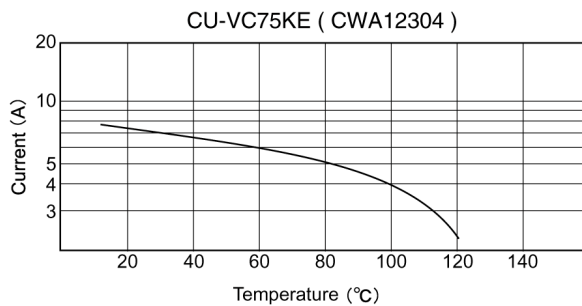

Fig. 3 OLP Characteristics (Compressor)



How to use electronic circuit diagram

Before using the circuit diagram, read the following carefully.

- * Voltage measurement
Voltage has been measured with a digital tester when the indoor fan is set at high fan speed under the following conditions without setting the timer.
Use them for servicing.
Voltage indication is in Red at all operations.

	Intake air temperature	Temperature setting	Discharge air temperature	Pipe temperature
Cooling	27°C	16°C	17°C	15°C

- * Indications for resistance
 - a. K....kΩ M....MΩ
 - W...watt Not indicated....1/4W
 - b. Type
 - Not indicated.....carbon resister

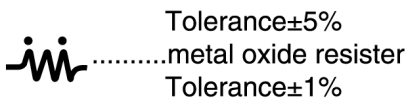

- * Indications for capacitor
 - a. Unit μ....μF P....pF
 - b. Type Not indicated....ceramic capacitor
 - (S).....S series aluminium electrolytic capacitor
 - (Z).....Z series aluminium electrolytic capacitor
 - (SU).....SU series aluminium electrolytic capacitor
 - (P).....P series polyester system
 - (SXE).....SXE series aluminium electrolytic capacitor
 - (SRA).....SRA series aluminium electrolytic capacitor
 - (KME).....KME series aluminium electrolytic capacitor

- * Diode without indication.....MA165
- * Circuit Diagram is subject to change without notice for further development.

TIMER TABLE

Name	Time	Test Mode (When test point Short-circuited)	Remarks
Sleep Mode Waiting	1 hr.	6 sec.	
Sleep Mode Operation	8 hrs.	48 sec.	
Real Timer	1 hr.	1 min.	
	10 min.	10 sec.	
	1 min.	1 sec.	
Time Delay Safety Control	2 min. 58 sec.	0 sec.	
Forced Operation	60 sec.	0 sec.	
Time Save Control	7 min.	42 sec.	
Anti-Freezing	4 min.	0 sec.	
Mode Judgement	20 sec.	0 sec.	
Soft	OFF	6 min.	36 sec.
	ON	10 min.	60 sec.
Deodorizing Control	Cooling	40 sec.	4 sec.
		70 sec.	7 sec.
		20 sec.	2 sec.
	Soft Dry	180 sec.	18 sec.
		40 sec.	4 sec.
360 sec.	36 sec.		
Comp. Reverse Rotation Detection	5 min.	30 sec.	Comp. ON 5 min. and above
	2 min.	0 sec.	
Comp./ Fan Motor Delay Timer	1.6 sec.	0 sec.	
Intake Air Anti-Freezing Prevention	16 min.	96 sec.	
Powerful Mode	15 min.	15 sec.	
Random FM Timer (Economy Mode)	5 sec.	5 sec.	
Random Auto Restart Control	0 ~ 150 sec.	0 sec.	

23.1. REMOTE CONTROL

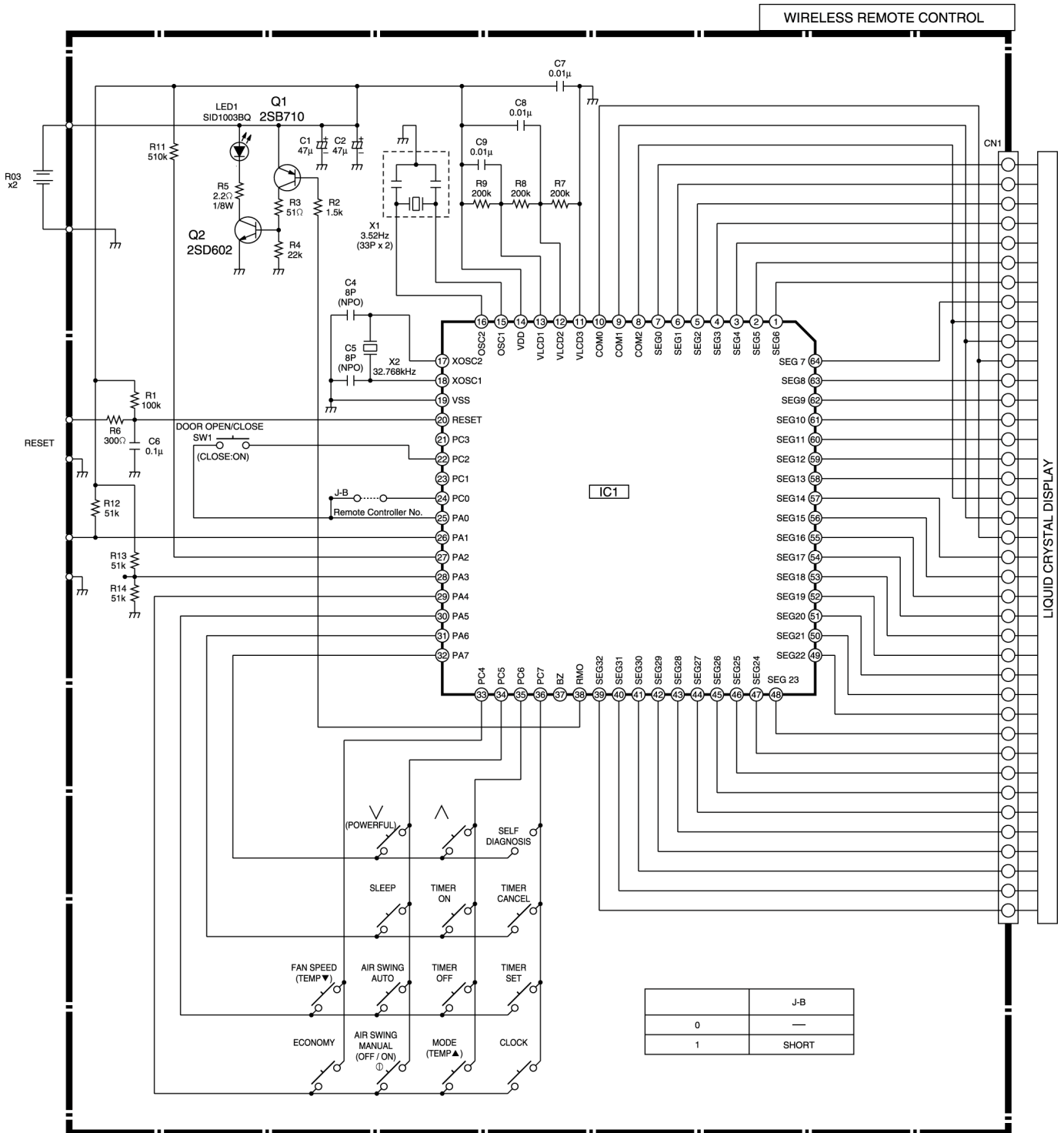

23.2. PRINT PATTERN INDOOR UNIT PRINTED CIRCUIT BOARD

TOP VIEW

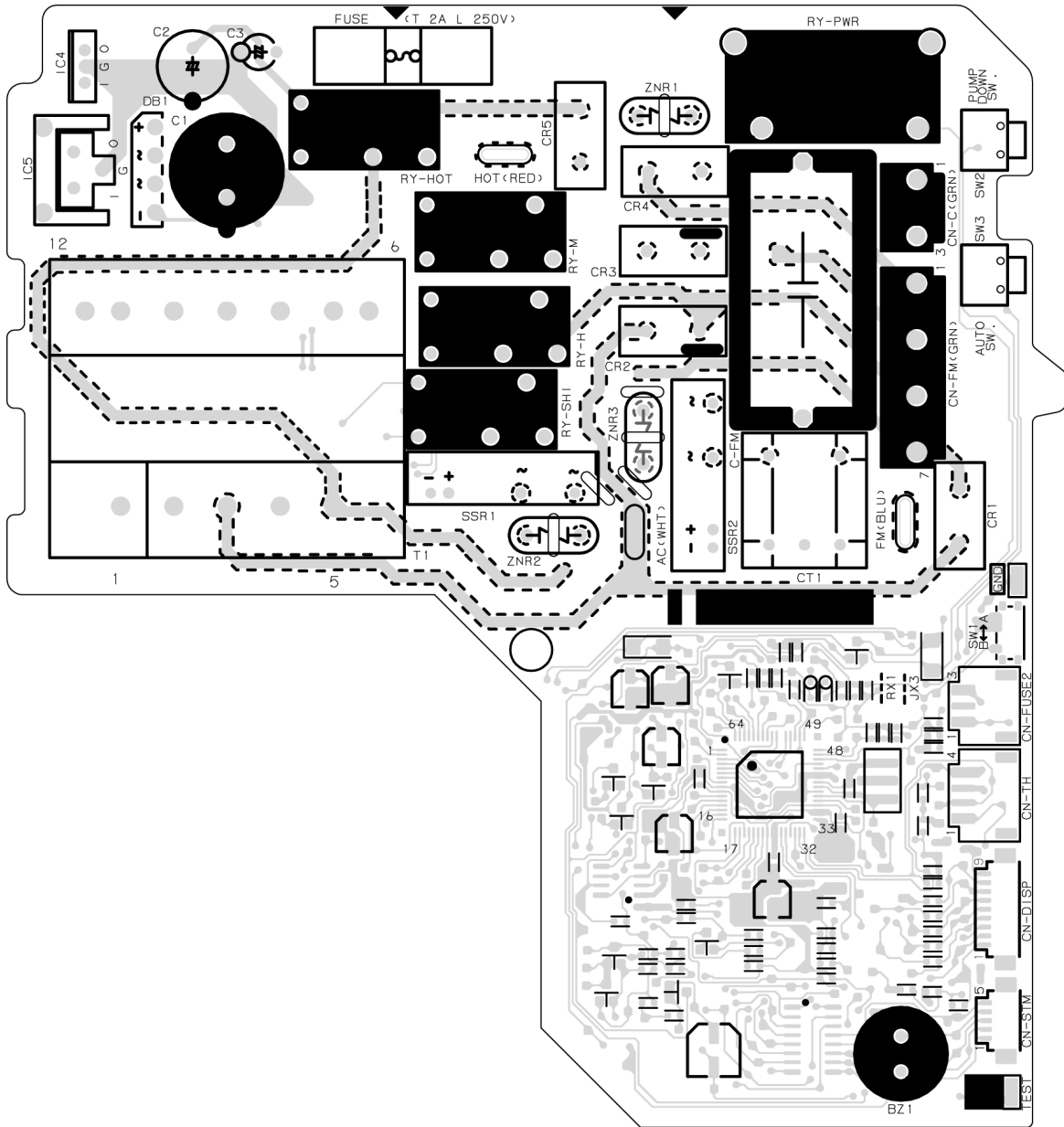

23.3. PRINT PATTERN INDOOR UNIT PRINTED CIRCUIT BOARD

BOTTOM VIEW

