



INSTALLATION INSTRUCTION • ISTRUZIONI D'INSTALLAZIONE • NOTICE D'INSTALLATION  
INSTALLATIONSANLEITUNGEN • INSTRUCCIONES DE INSTALACION  
INSTRUÇÕES DE INSTALAÇÃO • ΟΔΗΓΙΕΣ ΤΟΠΟΘΕΤΗΣΗΣ

OPERATING INSTRUCTION • ISTRUZIONI D'USO • NOTICE D'UTILISATION  
BEDIENUNGSANLEITUNGEN • INSTRUCCIONES DE USO  
MANUAL DE INSTRUÇÕES • ΟΔΗΓΙΕΣ ΧΡΗΣΕΩΣ

EG

I

F

D

E

P

GR

XFETTO DCI  
HPL / SCL V2

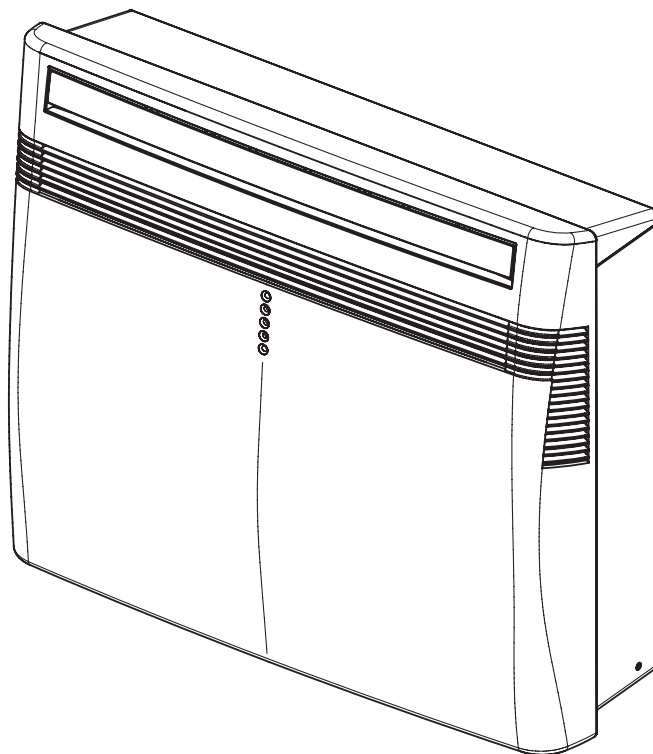
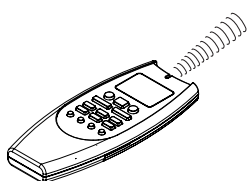

Air conditioner • Climatizzatore d'aria • Climatiseur  
Klimagerät • Acondicionador de aire  
Aparelho de ar condicionado • Κλιματιστικό

## CONTENTS

PRODUCT IDENTIFICATION	2
SIGNALING LAMPS	2
ACCESSORIES SUPPLIED WITH THE UNIT	3
INSTALLATION	3
BEFORE USING THE APPLIANCE	6
USING THE REMOTE CONTROL UNIT	7
REMOTE CONTROL UNIT	8
HOW TO SET THE PRESENT TIME	9
COOLING	9
HEATING	9
AUTOMATIC OPERATION	9
DEHUMIDIFYING (DRY)	9
FAN ONLY	10
ADJUSTING THE FAN SPEED	10
NIGHT MODE / ENERGY SAVING	10
ELECTRICAL HEATING	10
HIGH POWER MODE	10
SETTING THE TIMER	11
ADJUSTING THE AIR FLOW DIRECTION	12
OPERATION WITHOUT THE REMOTE CONTROL UNIT	12
TIPS FOR ENERGY SAVING	12
TROUBLESHOOTING	13
HOW TO DISCHARGE THE CONDENSATE WATER	14
CARE AND CLEANING	14



### INFORMATION FOR CORRECT DISPOSAL OF THE PRODUCT IN ACCORDANCE WITH THE EUROPEAN DIRECTIVE 2002/96/EC

At the end of its working life this equipment must not be disposed of as an household waste.

It must be taken to special local community waste collection centres or to a dealer providing this service.

Disposing of an electrical and electronic equipment and its batteries separately avoids possible negative effects on the environment and human health deriving from an inappropriate disposal and enables its components to be recovered and recycled to obtain significant savings in energy and resources.

In order to underline the duty to dispose of this equipment and batteries separately, the product is marked with a crossed-out dustbin.

## PRODUCT INFORMATION

If you have problems or questions concerning your Air Conditioner, you will need the following information. Model and serial numbers are on the nameplate applied on the unit.

Model No. \_\_\_\_\_

Serial No. \_\_\_\_\_

Date of purchase \_\_\_\_\_

Dealer's address \_\_\_\_\_

Phone number \_\_\_\_\_

## NOTE

This air conditioner is equipped with cooling, drying, heating and fan functions. Details on these functions are provided here following; refer on these descriptions when using the air conditioner. This product is covered by patent nr. 261412 issued on the 8th of Genuary 2009.

### DECLARATION OF CONFORMITY

This product is marked **CE** as it satisfies Directives.

- Low voltage no. 2006/95/CE.

- Electromagnetic compatibility no. 2004/108/CE, 92/31/CEE and 93/68/CEE.

This declaration will become void in case of misusage and/or non observance though partial of Manufacturer's installation and/or operating instructions.

### F-GAS Regulation (EC) No. 842/2006

Do not vent R410A into atmosphere: R410A is a fluorinated greenhouse gas, covered by Kyoto Protocol, with a Global Warming Potential (GWP) = 1975.

## ALERT SYMBOLS

The following symbols used in this manual, alert you to potentially dangerous conditions to users, service personnel or the appliance:



### WARNING

This symbol refers to a hazard or unsafe practice which can result in severe personal injury or death.



### CAUTION

This symbol refers to a hazard or unsafe practice which can result in personal injury or product or property damage.

### OPERATING LIMITS

COOLING		
MAXIMUM CONDITIONS	OUTDOOR TEMPERATURE	43°C D.B.
	ROOM TEMPERATURE	32°C D.B./23°C W.B.
MINIMUM CONDITIONS	OUTDOOR TEMPERATURE	-15°C D.B.
	ROOM TEMPERATURE	10°C D.B./6°C W.B.
HEATING		
MAXIMUM CONDITIONS	OUTDOOR TEMPERATURE	24°C D.B./18°C W.B.
	ROOM TEMPERATURE	27°C D.B.
MINIMUM CONDITIONS	OUTDOOR TEMPERATURE	-15°C D.B.
	INDOOR ROOM	30% R.H.
DEHUMIDIFYING (DRY)		
MAXIMUM CONDITIONS	OUTDOOR TEMPERATURE	43°C B.S.
	ROOM TEMPERATURE	32°C B.S. / 80% R.H.
MINIMUM CONDITIONS	OUTDOOR TEMPERATURE	-15°C B.S.
	ROOM TEMPERATURE	10°C B.S. / 80% R.H.

## PRODUCT IDENTIFICATION

1. Wireless remote control unit
2. Signaling lamps
3. Supply air deflector
4. Lateral air intake grilles
5. Front air intake grille
6. Air filter
7. Electric cable with plug
8. Air inlet hole
9. Air outlet fan
10. Suspension panel
11. Service tube for condensate discharge
12. Tube for condensate discharge

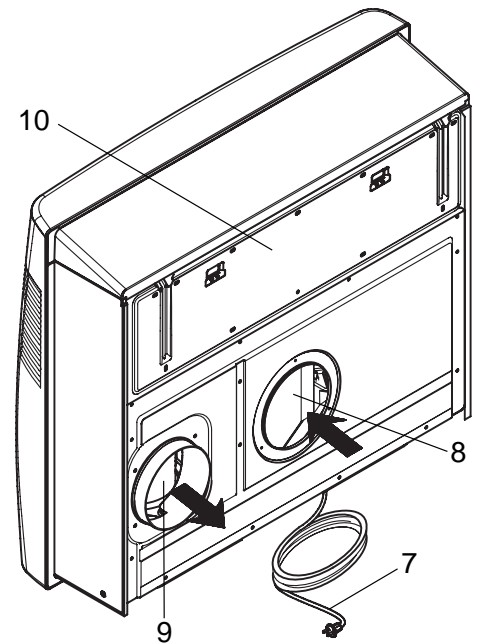
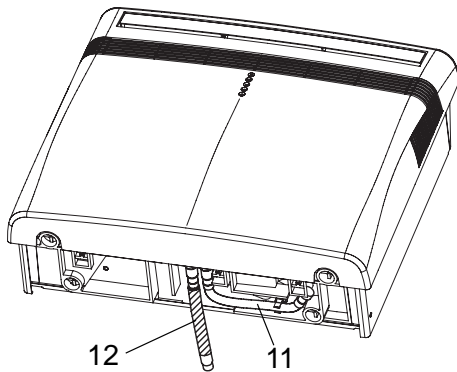
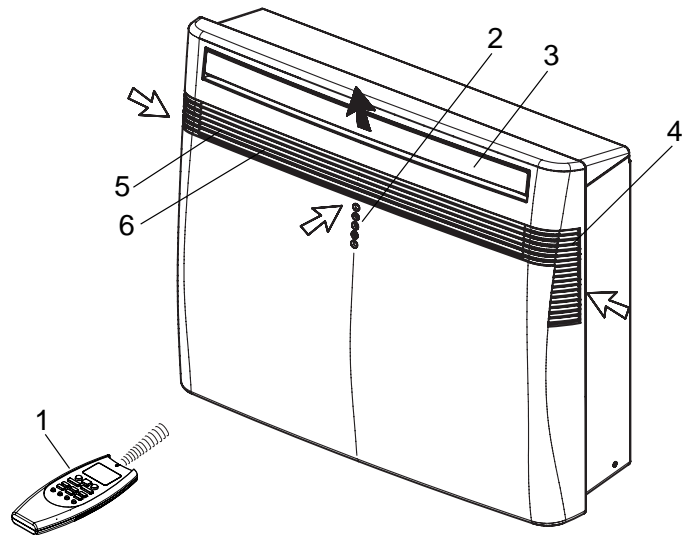

## SIGNALING LAMPS

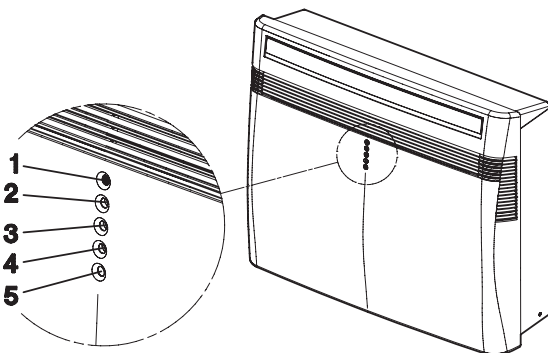

1. **Receiver** : receives signals transmitted from the remote control.
2. **TIMER lamp**: This lamp lights up when the system is being controlled by the timer.
3. **STANDBY lamp**: This lamp lights up when the air conditioner is connected to the power and ready to receive the remote control command.
4. **OPERATION lamp**: This lamp lights up during operation. It blinks together with other lamps in case of troubles (see AUTO-DIAGNOSIS table).

5. **Operation button (without remote control)**: Push the button to change from one operation mode to the other (OFF, COOL and HEAT).



### WARNING

The OFF position does not disconnect the power. Use the main power switch to turn off power completely.

### NOTES

- It is possible to set the air conditioner in order to let the OPERATION, TIMER and STANDBY lamps always OFF, even during operation. Press contemporary the IFEEL and FAN buttons on the remote control unit for more than 5 seconds. Repeat the same procedure to set again the normal operation conditions.
- In case of troubleshooting the air conditioner diagnostic system activates the lamps accordingly, even if they are set to OFF. See paragraph TROUBLESHOOTING for further details.

## ACCESSORIES SUPPLIED WITH THE UNIT

1. PLASTIC TUBE (1pcs.)
2. EXTERNAL GRILLES (2pcs.)
3. INTERNAL GRILLES (2pcs.)
4. TENSION BARS (2pcs.)
5. FULL SCALE DIAGRAM (1pcs.)
6. RAWL PLUGS + SCREWS (15pcs.)
7. REMOTE CONTROL UNIT (1pcs.)
8. BATTERIES FOR REMOTE CONTROL (2pcs.)

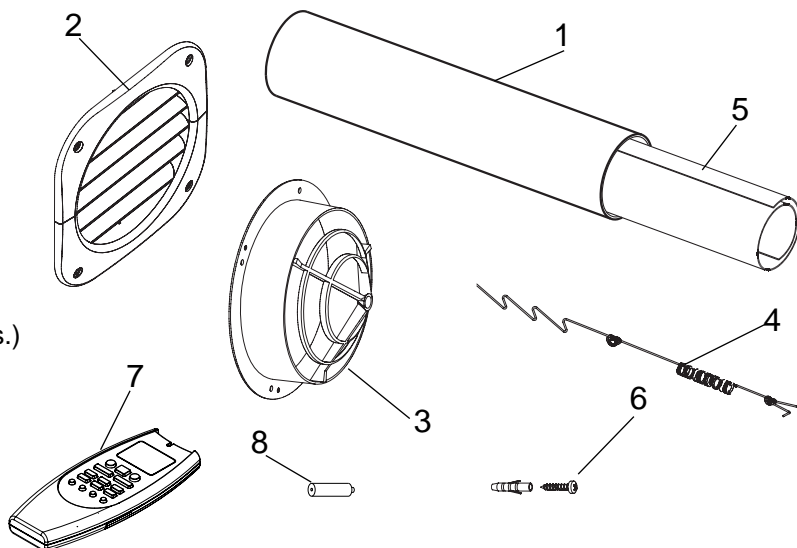

## INSTALLATION

The installation should be carried out by a qualified installer, following the instructions as shown.

### INSTALLATION SITE SELECTION

- The wall must be a perimeter one.
- Fix the unit at a minimum height of 10 cm and a maximum height of 100 cm.
- Select a sufficiently strong location to support the weight of the unit.
- Allow access for maintenance operation around the unit.
- Make sure that there are no obstacles around the unit affecting the free circulation of air.
- Avoid installing the unit with the air flow directly toward passerby people, electric appliances or heat sources.

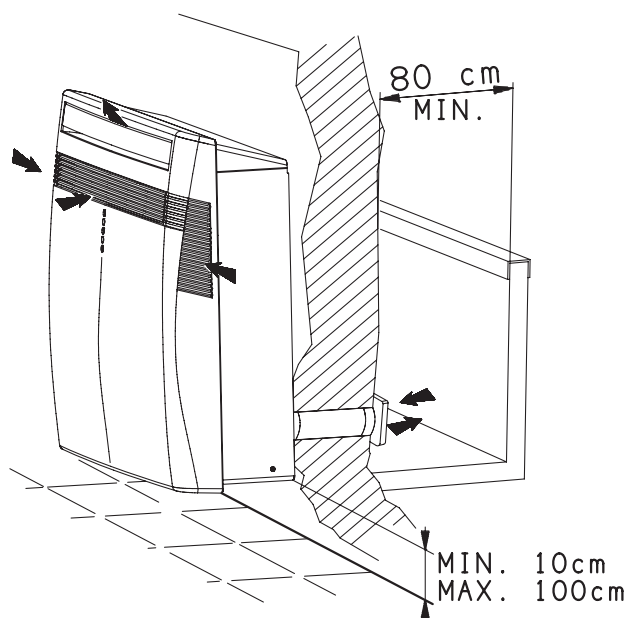

### CAUTION

After the selection of the installation site, according to the above mentioned points, be sure not to make holes in areas where electrical wiring or conduits are located, damaging them.

Make sure that there are no obstacles in the conduits inside the wall affecting the free circulation of the external air. The unit must be kept at a minimum distance of 80 cm from any wall or obstacle.

### MOUNTING OF THE UNIT

- Apply at the wall the full scale diagram, fix and level it.
- Drill the two holes  $\varnothing 162$  mm and eventually the hole  $\varnothing 35$  mm in case of heat pump unit for the condensate drainage toward the outside (assure a positive slope toward the outside).

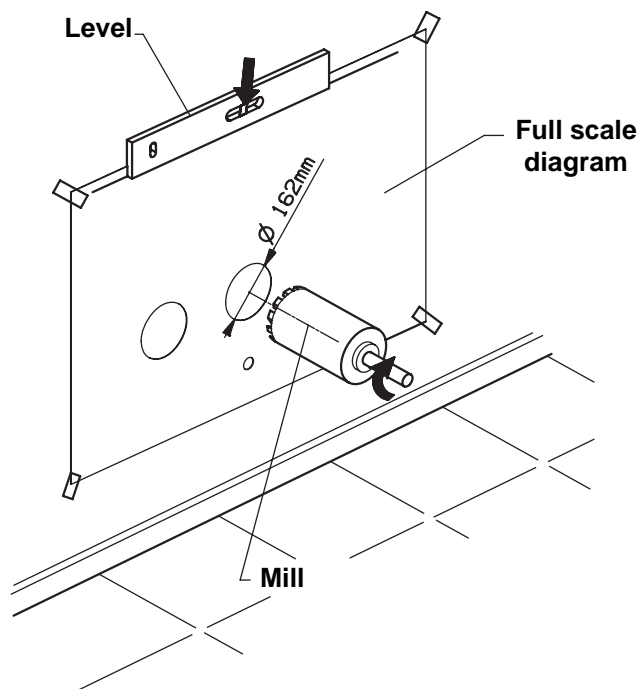

- Insert in the two holes the supplied plastic tube; cut it at the right length: it is necessary to measure the thickness of the wall and subtract 70 mm.

- Fix the two anti-intrusion grilles and the two external grilles with the blades toward the bottom using wall rawl plugs and screws.

- In case it is not possible to fix the two external grilles directly at the wall, hook the two grilles to the internal ones using the supplied tension bars, as follows:

- a) Bend them, fix the hook of the spring, insert them inside the tube and open them toward the outside.
- b) Choose the proper hook of the tension bar in order to lengthen the spring of 15-20 mm and hook it to the internal grille.
- c) Eliminate the exceeding part of the tension bar cutting it near the hooking points.

- In case of very thin walls (less than 10 cm) it is necessary to mount the internal anti-intrusion grilles on the back of the unit removing the gaskets (a) from the back side and applying them around the grilles. The tube and the external grilles will not be used.

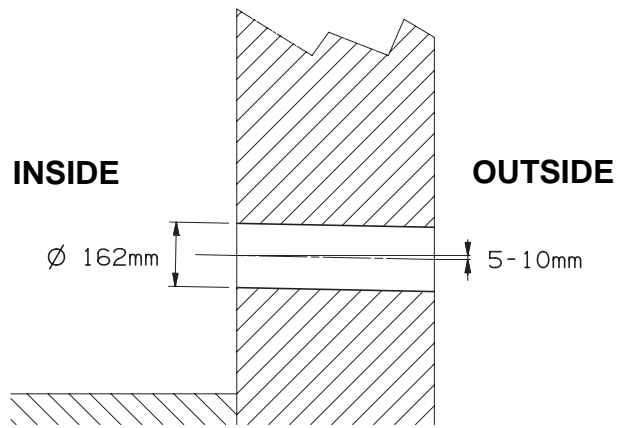

EG

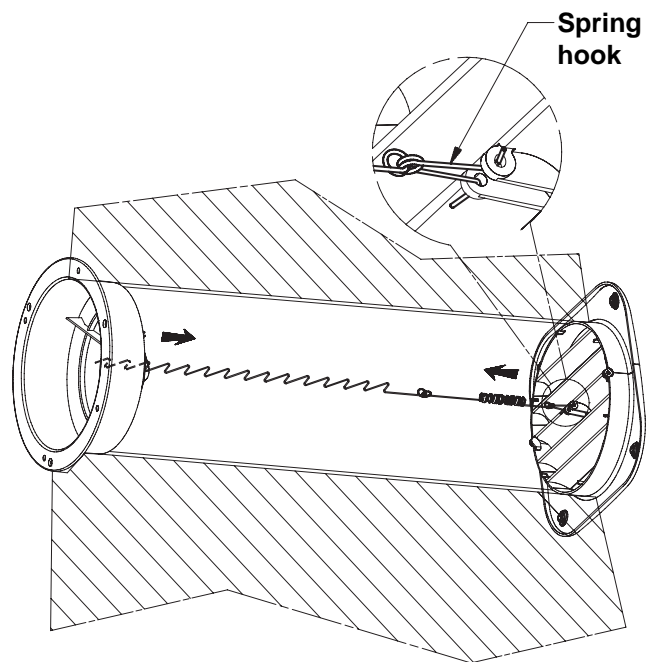
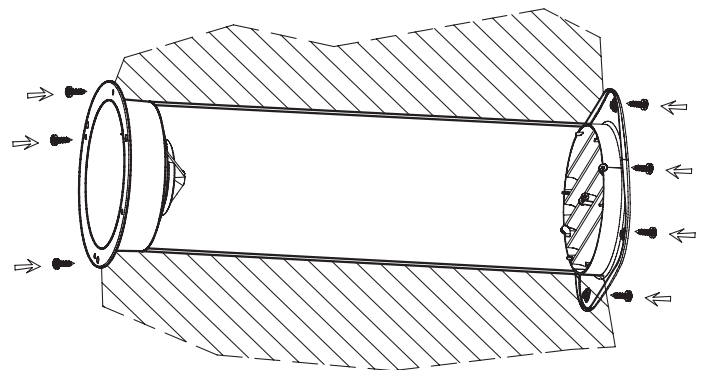

**CAUTION**

The manufacturer assumes no responsibilities if this safety instruction is not observed.

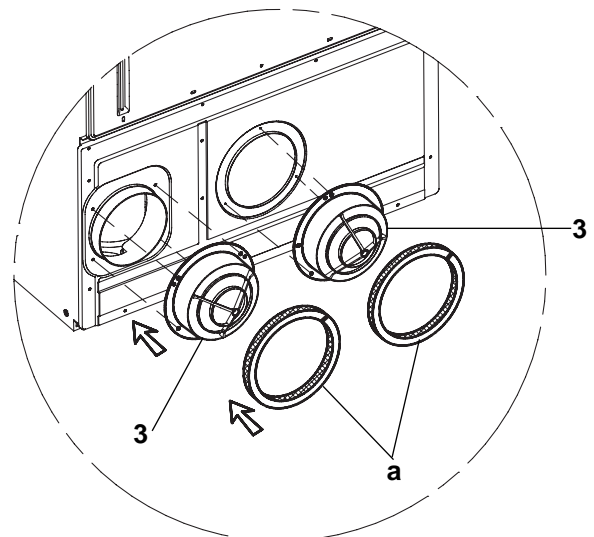
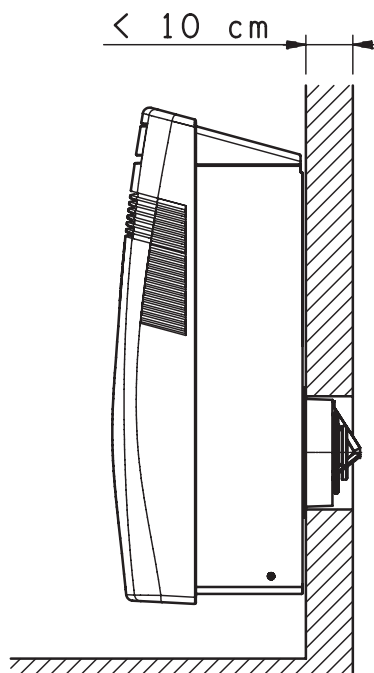

**WARNING!** The supplied plastic conduits can be used for wall thickness up to 50 cm; in special cases (i.e. installations in a garret) it can be necessary to utilise longer tubes. The maximum allowable length is 2 m. You can go to any building material retailer, buy the plastic tube of the same diameter ( $\varnothing 160$  mm), of the proper length and cover it outside with insulating material (thickness: about 3-4 cm).

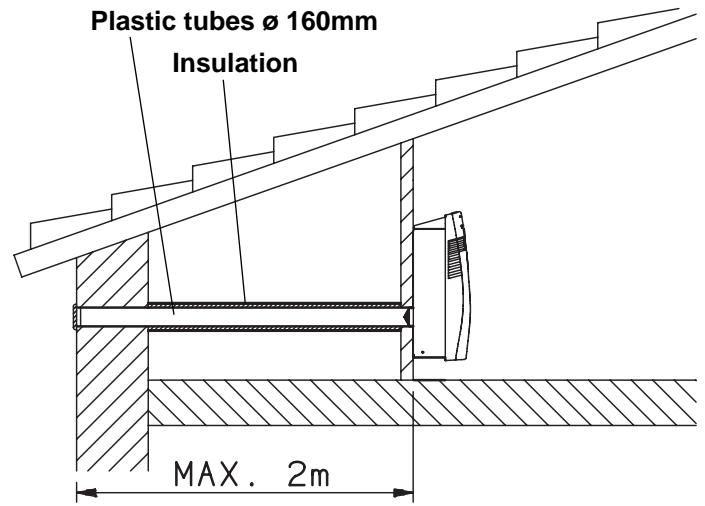

**EG**

- Fix the suspension panel to the wall in the position indicated on the full scale diagram.  
The quantity and the type of rawl plugs (not supplied) depends on the consistence of the wall; do not let any space between the panel and the wall.
- Hang up the unit at the panel inserting the back fan outlet in the grille.
- Predispose a condensate drainage toward the outside (a) making a hole  $\varnothing 35$  mm as indicated on the full scale diagram; if it is not possible, maintain the condensate tube inside (b) and make a proper drainage. Assure always a positive slope of at least 1cm/m.
- Connect the unit inserting the plug in the power socket.
- Verify the correct operation.

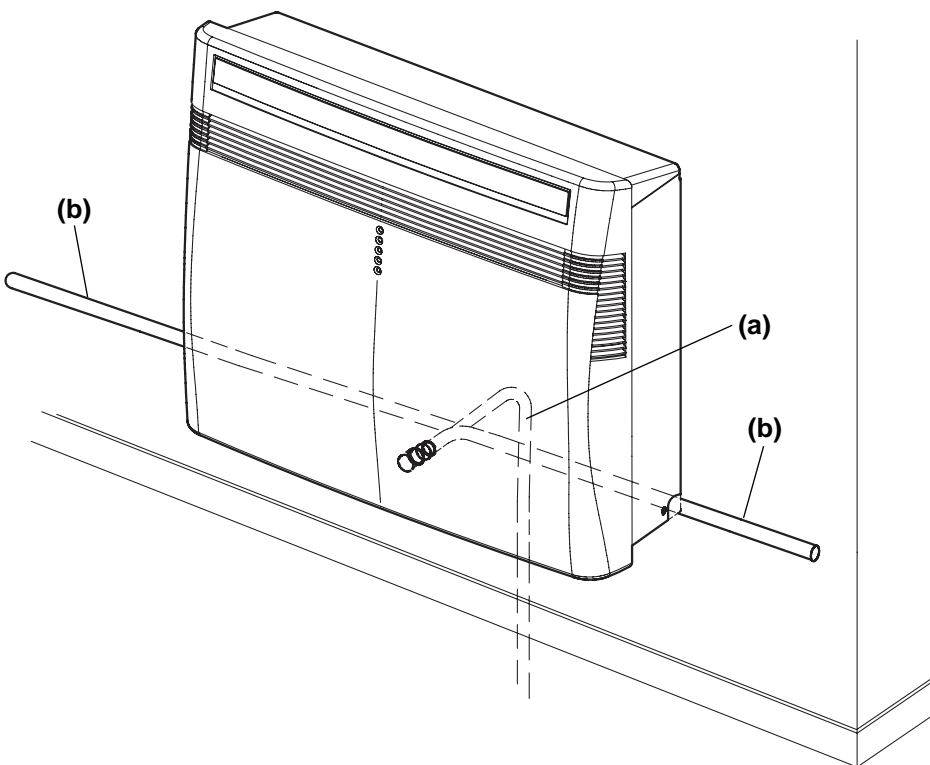
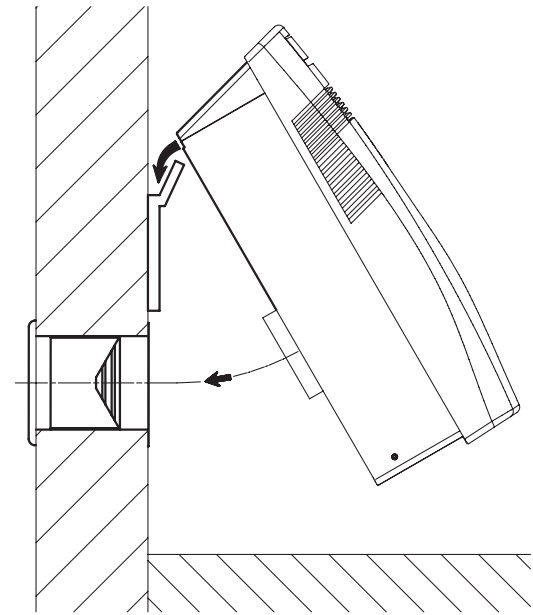

## BEFORE USING THE APPLIANCE

- Check that the power supply at the location where the air conditioner is going to be used is 220-240V ~ 50Hz .
- Make sure that the electrical installation is suitable to supply continuously current necessary for the air conditioner in addition to that already used by other electric appliances (white goods, lighting). See the max electric input indicated on the name plate positioned on the air conditioner.
- The installation of a double-pole switch, protected by 16 A fuses of the delayed type, upstream the electricity wall socket, is recommended.
- The unit has to be connected according to the local electrical rules.
- Make sure that circuit breakers, fuses, etc, are of sufficient capacity to handle a start-up current of 20 A (generally less than 1 second).
- Do not install the air conditioner where it could be wetted by drops of water (i.e. in laundries).
- Before connecting the air conditioner to a power socket, make sure that the socket is provided with an earth connection in compliance with local codes.
- Never use the power plug as a mean to start or stop the air conditioner: always use the ON/OFF button of the remote control unit or the operation button on the unit.
- **WARNING!** Do not stick anything into the air outlet of the air conditioner. This is very dangerous because the fan is rotating at high speed.
- **WARNING!**  
The air conditioner is provided with a time-guard system, which does not allow re-starting of compressor until after 3 minutes from a previous stop.
- Make sure that there are no obstacles around the unit affecting the free circulation of air. Do not block the air intakes and outlet of the unit with curtains or other. Never put objects on the top of the unit.
- When you switch on the air conditioner for the first time, it reaches the maximum efficiency after at least one hour of operation.
- The manufacturer assumes no responsibilities if the safety regulations or local codes are not observed.



### WARNING

Always unplug the unit from the power socket before moving or cleaning it and, in case you should remove it, discharge the eventual condensate water inside the bottom plate.

## USING THE REMOTE CONTROL UNIT

### HOW TO INSTALL BATTERIES

- Remove the lid in the rear part of the remote control unit and check the settings of the dipswitch as shown below:

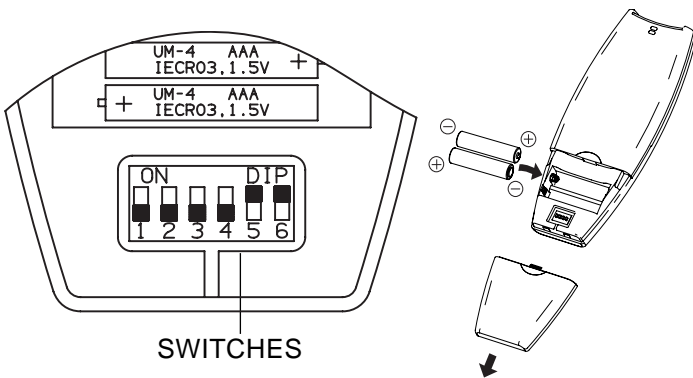

- Insert two AAA alkaline batteries of 1,5 V-DC making sure that point in the direction marked in the battery compartment. The displayed time flashes. Press the SEL TYPE button. Remote controller is now ready for operation.
- The batteries last about six months. Depending on how much you use the remote control unit. Remove the batteries if you do not use the remote control unit for more than one month. Replace the batteries when the remote control unit lamp fails to light, or when the air conditioner does not receive the remote control unit signals.
- The batteries of the remote control contain polluted substances exhausted batteries must be disposed according to the laws in force.

### HOW TO REMOVE BATTERIES

- Remove the lid.
- Press the battery toward the negative end and lift it out by its positive end (as shown in the figure).
- Remove the other battery in the same way.

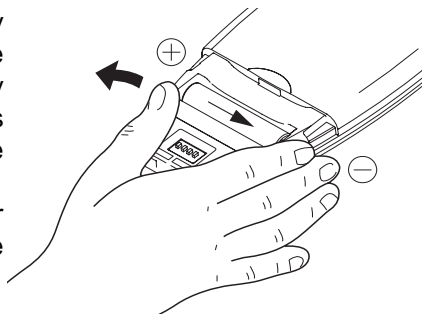

## TEMPERATURE SENSOR SELECTOR

- Under normal conditions the room temperature is detected and checked by the temperature sensor placed in the remote controller (I FEEL icon displayed). This function is designed to provide a comfortable room temperature by transmitting the temperature control command from the location next to you. When using this function, the remote control should always be pointed at the air conditioner, therefore it should be placed in a position in which it is visible by the indoor unit (for example, do not put it in a drawer).
- It is possible to disable the remote controller room sensor pressing the I FEEL button. In this case the I FEEL icon on the remote controller display lights off and only the sensor placed in the air conditioner becomes active.

### NOTE

The remote control unit transmits signals to the indoor unit each time you press a key and at any temperature change detected by the IFEEL sensor. In case of troubles (low batteries, remote control placed in a position not visible by the indoor unit,...) room temperature control is automatically switched to the sensor of the indoor unit. In this case, the temperature around the remote control unit may differ from the temperature detected in the air conditioner position.

### OPERATION WITH THE REMOTE CONTROL UNIT

When using the remote control unit, always point the unit transmitter head directly at the air conditioner receiver.

### HOW TO TURN ON THE AIR CONDITIONER

Press the ON/OFF button to turn the air conditioner on. The operation lamp will light up, indicating the unit is in operation.

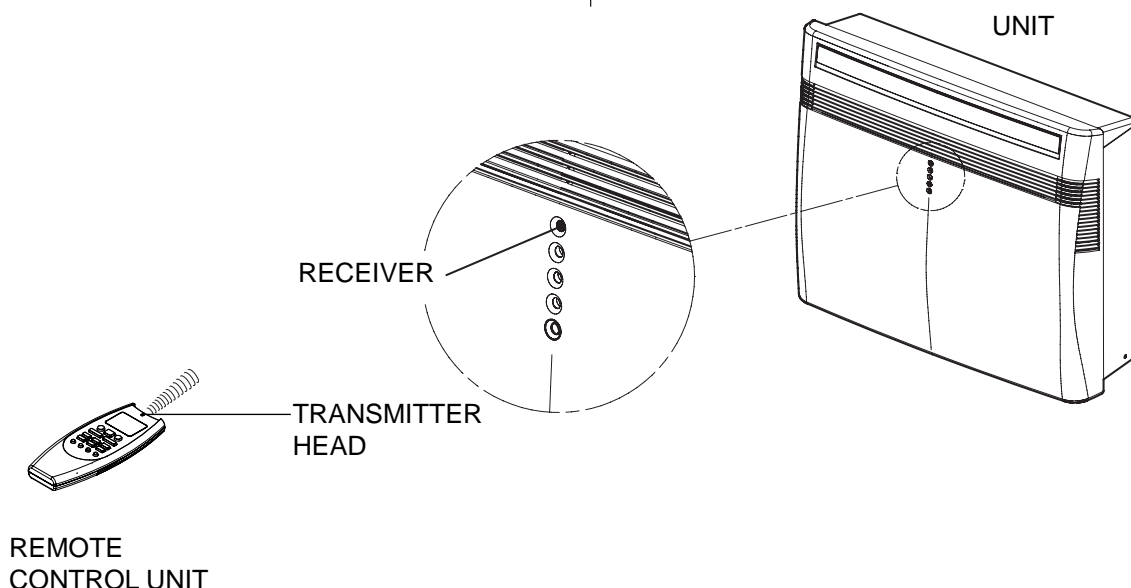



# REMOTE CONTROL UNIT

## DISPLAY

Information is displayed when the remote controller is switched on. If switched off, only the operating mode, the room temperature and the clock are shown

I FEEL mode is active (remote controller sensor active)

### Operation mode

- Automatic
- Cooling
- Heating
- Dehumidification
- Fan

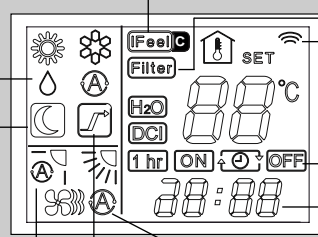

Electrical heating is active

Displayed when transmitting data

Timer modes

Clock

Room temperature

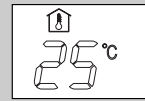

Set point temperature

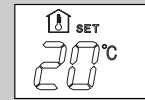

Night mode



Oscillation Flap



HIGH POWER mode

### Fan speed

- Automatic
- High speed
- Medium speed
- Low speed

## MODE SELECTOR BUTTON

Press this button to modify the air conditioner mode.

(cooling)

The air conditioner makes the room cooler.

(dry)

The air conditioner reduces the humidity in the room.

(automatic)

When this setting is selected, the air conditioner calculates the difference between the thermostat setting and the room temperature and automatically switches to the "cool" or "heat" mode.

(fan)

The air conditioner works only as a circulation fan.

## SENSOR

A temperature sensor inside the remote control unit detects the room temperature.

## TRANSMITTER

When you press the buttons of the remote control unit, the mark appears on the display to transmit the setting changes to the receiver in the air conditioner.

## MODE SELECTOR BUTTON

Press this button to modify the air conditioner mode.

(heating)

The air conditioner makes the room warmer.

(automatic)

When this setting is selected, the air conditioner calculates the difference between the thermostat setting and the room temperature and automatically switches to the "cool" or "heat" mode.

(electrical heating)  
blinking **FAN HEATER MODE**

## TEMPERATURE SETTING BUTTONS

### - (cooler)

Press this button to decrease the set temperature.

### + (warmer)

Press this button to increase the set temperature.

## "FAN" BUTTON (fan speed)

Fan speed is automatically selected by the microcomputer.

High speed.

Medium speed.

Low speed.

## NIGHT/ECO BUTTON

Press this button in order to select the NIGHT/ECO mode.

## "HIGH POWER" BUTTON

## CLOCK AND TIMER SETTING BUTTON

Press this button in order to:

- set the clock
  - set the ON/OFF timer
- For details refer to paragraphs "SETTING THE HOUR" and "SETTING THE TIMER".

## HOURS AND MINUTES SETTING BUTTONS

With these buttons is possible to set the clock and the timer. For details refer to paragraphs "SETTING THE HOUR" and "SETTING THE TIMER".

## ON/OFF BUTTON

This button turns the air conditioner ON and OFF.

## FLAP BUTTON

Press this button in order to select the desired function.

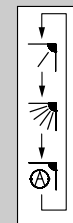

Fixed: six position

Continuous oscillations

Automatic oscillations

## IFEEL/IFEEL C SENSOR SELECTOR

Press this button to modify the active setting for room temperature detection (from remote controller to air conditioner and viceversa).

## ELECTRICAL HEATING BUTTON

## TIMER SELECTION BUTTON

Press this button to select the type of timer to activate. For details refer to paragraph "SETTING THE TIMER".

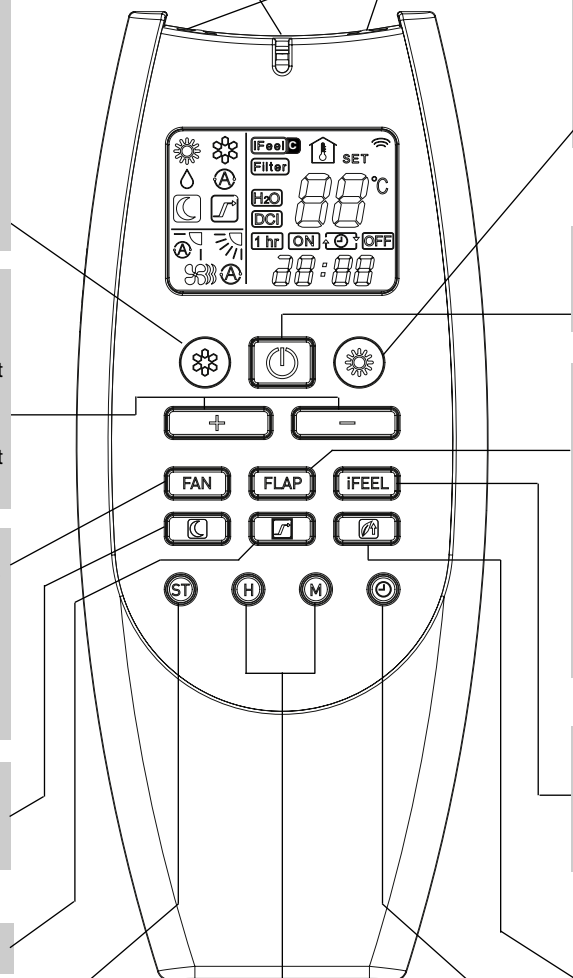



## HOW TO SET THE PRESENT TIME

1. Press the button ST three times.  
The time indication alone flashes.
2. Press the H button until the present time hour is displayed. Press the M button until the present time minutes are displayed. The display will automatically stop flashing.

## COOLING

### NOTE

Verify that the unit is connected to the main power and the STANDBY lamp is light up.

1. Set the  selector to COOL (symbol  on the display).
2. Press the +/- buttons (temperature selection) to set the desired temperature (the temperature range is between 32 °C max. and 10 °C min.).

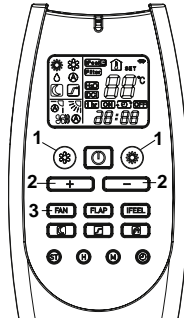



THE DISPLAY SHOWS THE SELECTED TEMPERATURE.



AFTER 5 SECONDS FROM THE REQUIRED TEMPERATURE SETTING THE DISPLAY WILL SHOW THE ROOM TEMPERATURE AGAIN.

3. Press the FAN button to select the fan speed.

## HEATING

1. Set the  selector to HEAT (fixed symbol  on the display).
2. Press the +/- buttons (temperature selection) to set the desired temperature (the temperature range is between 32 °C max. and 10 °C min.).



THE DISPLAY SHOWS THE SELECTED TEMPERATURE.



AFTER 5 SECONDS FROM THE REQUIRED TEMPERATURE SETTING THE DISPLAY WILL SHOW THE ROOM TEMPERATURE AGAIN.

3. Press the FAN button to select the fan speed.

### NOTE

For several minutes after the start of heating operation, the indoor fan will stop until the indoor heat exchanger coil has warmed up sufficiently. This is because the COLD DRAFT PREVENTION SYSTEM is operating. During this period, the STANDBY lamp remains lit.



## DEFROSTING OF OUTDOOR UNIT HEAT EXCHANGER

When the outdoor temperature is low, frost or ice may appear on the heat exchanger coil, reducing the heating performance. When this happens, a protection function for the heat exchanger defrosting is activated. During this function operation, the fan of the indoor unit stops. Heating operation restarts after several minutes. (This interval will vary slightly depending on the room and outdoor temperature).

## HEATING PERFORMANCE

A heat pump conditioner heats a room by taking heat from outside air. The heating efficiency will fall off when the outdoor temperature is very low. If enough heat is not obtained with this air conditioner, use another heating appliance in conjunction with it.

## AUTOMATIC OPERATION

1. Set the  or  selector to AUTO (symbol  on the display).
2. Press the +/- buttons (temperature selection) to set the desired temperature (the temperature range is between 32 °C max. and 10 °C min.).



THE DISPLAY SHOWS THE SELECTED TEMPERATURE.

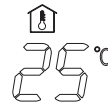

AFTER 5 SECONDS FROM THE REQUIRED TEMPERATURE SETTING THE DISPLAY WILL SHOW THE ROOM TEMPERATURE AGAIN.

When this setting is selected, the air conditioner calculates the difference between the thermostat setting and the room temperature and automatically switches to the COOL or HEAT mode as appropriate.

3. Press the FAN selector button to the setting you want.

Example of operation diagram in the  (Auto) mode with the set room temperature at 23°C.

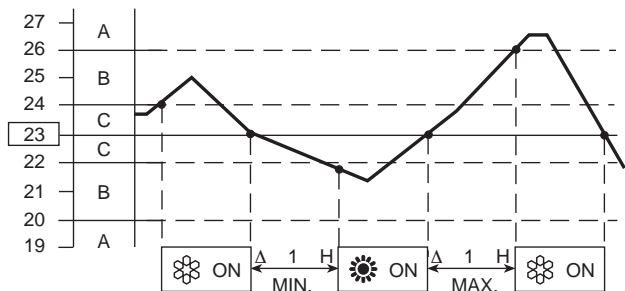



### NOTE

The air conditioner changes the operation mode (from cool to heat or vice versa), if one of the following conditions occurs:

- **ZONE A:** changes if the difference between the room temperature and the temperature set on the remote control unit is at least 3°C.
- **ZONE B:** changes if the difference between the room temperature and the temperature set on the remote control unit is at least 1°C, one hour after the compressor stop.
- **ZONE C:** never changes if the difference between the room temperature and the temperature set on the remote control unit is no more than 1°C.

## DEHUMIDIFYING (DRY)

1. Set the  button to DRY. The icon  is displayed.
2. Press the +/- buttons (temperature selection) to set the desired temperature (the temperature range is between 32 °C max. and 10 °C min.).



THE DISPLAY SHOWS THE SELECTED TEMPERATURE.





AFTER 5 SECONDS FROM THE REQUIRED TEMPERATURE SETTING THE DISPLAY WILL SHOW THE ROOM TEMPERATURE AGAIN.

## NOTE

- Use DRY operation when you want to reduce the humidity in the room.
- Once the room temperature reaches the set level, the unit repeats the cycle of turning on and off automatically.
- During DRY operation, the fan speed is automatically set (Remote control lamp  is ON) to prevent overcooling.
- Dry operation is not possible if the indoor temperature is 10 °C or less.

## FAN ONLY

If you want to make air circulate without any temperature control, press  button until only the  fan symbol appears on the display.

## ADJUSTING THE FAN SPEED

### AUTOMATIC



Simply set the FAN selector to the  position. A microcomputer automatically controls the fan speed when the AUTO mode is selected. When the air conditioner starts operating, in heating or cooling, the fan speed varies (high - medium - low - very low) according to the thermal load of the room.

### NOTE





The automatic speed is not available in FAN ONLY mode.

### MANUAL

If you want to manually adjust speed just set the FAN selector as desired.

 High speed     Med. speed     Low speed

## NIGHT MODE / ENERGY SAVING

- This mode enables you to save energy.
1. Set the  or  selector to cool, dry or heat.
  2. Press the  button.
  3. The  mark appears on the display. Press the button again to release the function.

### What does the NIGHT mode mean?

When you select the NIGHT mode, the air conditioner will modify automatically the set temperature after 60 minutes. This enables you to save energy without sacrificing your comfort.

OPERATING MODE	SET TEMPERATURE CHANGE
Heating	Lowered by 1 °C
Cooling and Dehumidifying	Raised by 2 °C

### NOTA

During the NIGHT mode the internal fan speed is automatically lower and reduces the noise.

## COOLING AND DEHUMIDIFYING

Function selection

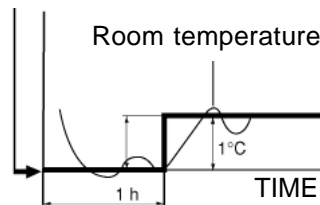

## HEATING

Function selection

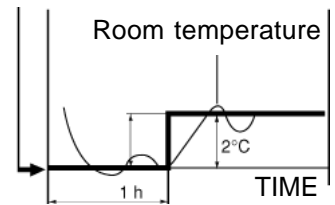



## ELECTRICAL HEATING

This air conditioner is equipped with an electrical heater that can operate in three ways:



- **AUTO MODE** - During AUTOMATIC OPERATION the electrical heater switches on automatically depending on the room temperature, the set temperature and the outdoor temperature.

- **BOOSTER** - During HEATING OPERATION press the  button on the remote control in order to activate the electrical heater that will switch on only depending on the room temperature and the set temperature.

- **FAN HEATER** - During FAN OPERATION press FILTER  button on the remote control or press three times the selector (blinking symbol  on the display) in order to activate the electrical heater.

## HIGH POWER MODE

You can select High Power only during cooling or heating mode and not during automatic, dehumidifying (dry) and fan mode. High Power mode allows to obtain the maximum air conditioner's efficiency, either in cooling or heating mode (heat pump). The user can choose to activate the High Power mode, using the remote control unit, after having selected cooling or heating mode and during this latter mode, it can be used together with the electrical heater in Booster way. Under these conditions the air conditioner will reach its maximum thermal power and consequently also the maximum electrical consumption and noise; it is recommended to use the High Power mode only if the outdoor temperature is very low and the selected room temperature is difficult to be reached. On the contrary, if you want to obtain the best performance in efficiency and silentness, High Power mode is not recommended: let the air conditioner run in normal condition (factory default program).

To activate High Power mode it is necessary (after having selected the cooling or heating mode) to press two times the HIGH POWER button  (always waiting for the acoustic signal confirmation); at the first pressure of the button the symbol  switches on, at the second pressure this symbol disappears; at this point the operation lamp (green lamp on the front panel of the air conditioner) begins blinking slowly, indicating that High Power mode is activated; it can be deactivated using the same procedure; therefore the green lamp will stop blinking and it will be switched on permanently.

## NOTES

- During the high power operation the room temperature could not correspond to the set temperature.
- HIGH POWER program remains set also if you change operation mode from COOL to HEAT or vice versa and if you switch OFF and ON again the air conditioner.

EG

## SETTING THE TIMER

### A) HOW TO SET THE ON TIME

1. Press the ST button once.  
The ON and time indications flash.
2. Press the H button until the designed hour is displayed.  
Press the M button until the designed minutes are displayed. The display will change automatically back to show the present time after 10 sec.
3. Press the ON/OFF button to start the air conditioner.
4. Press the  button to activate the ON timer.

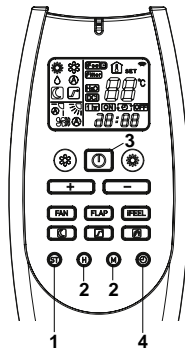
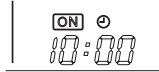

### B) HOW TO SET THE OFF TIME

1. Press the ST button twice.  
The OFF and time indications flash.
2. Press the H button until the designed hour is displayed.  
Press the M button until the designed minutes are displayed. The display will change automatically back to show the present time after 10 sec.
3. Press the ON/OFF button to start the air conditioner.
4. Press the  button two times to activate the OFF timer.

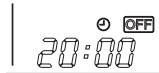

### C) HOW TO SET A PROGRAM FOR DAILY ON/OFF OPERATION (OR VICEVERSA)

1. Set the timer ON/OFF as shown in A) and B).
2. Press the ON/OFF button to start the air conditioner.
3. Press three times the  button to activate the DAILY timer.

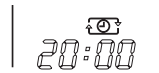

## NOTE

After timer setting, press ST button in order to check the ON/OFF setting time.

## SETTING THE 1 HOUR TIMER

This function causes the unit to operate for one hour at the set conditions, regardless of whether the unit is on or off.

### TIMER SETTING PROCEDURE.

- Press four times the  button. The 1 HOUR TIMER mark will appear on the display.



### CANCELLATION PROCEDURE

- Press the ON/OFF button to turn the air conditioner off.
- Wait for the indoor unit to stop operating.
- Press the ON/OFF button again to turn the air conditioner on.

## SETTING THE HOLIDAY TIMER

The Holiday Timer function allows you to activate the indoor unit (either it is the only one of a monosplit system or one unit of a multisplit system), with a delay up to 99 days you can set for the Daily Timer, On Timer, Off Timer functions (not available for 1 HOUR TIMER) already explained in this manual.

With this function you can set the air conditioner to be switched on again after a long week end, a holiday of one week or more, ecc...

To activate this function you have to follow the following steps in order :

1. Keep pressed the button "TIMER SELECTION" of the remote control unit (clock figure) for more than 6~7 seconds. In this way you enter the menu to select the number of days of delay.
2. Select the desired timer (Daily Timer, On Timer, Off Timer) pressing on the same button "TIMER SELECTION".
3. Set the desired number of days of delay using the button "+".
4. Keep pressed again the button "TIMER SELECTION" for more than 6~7 seconds. You enter again the normal menu of the remote control unit.

At this point, the symbol of the desired timer will flash and the selected timer will be activated only after the set number of delay days.

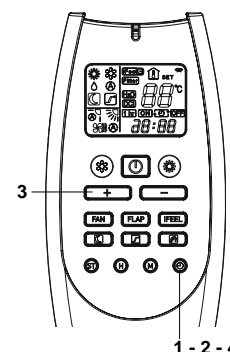

## ADJUSTING THE AIR FLOW DIRECTION

### HORIZONTAL (manual)

The horizontal air flow can be adjusted by moving the vertical vanes to the left or right, as indicated in the following figures.

### VERTICAL (with remote control unit)

Make sure that the remote control unit has been turned on. Press the FLAP button to select the sweep function or to choose one of the six positions of the flap.



#### CAUTION

Set vertical vanes to the front position during COOLING/DRY operation if humidity is high.

If the vertical vanes are set to the left-most or right-most position, condensation will form around the air outlet and drip off.



#### CAUTION

Do not move the flap with your hands when the air conditioner is running.

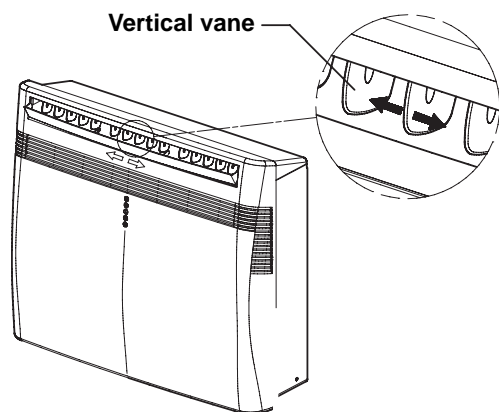

### Sweep function

The flap starts moving up and down to deliver air over the sweep range.

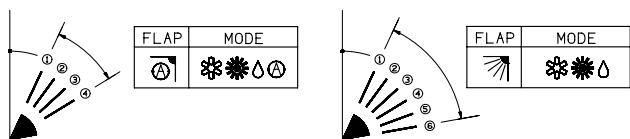

### NOTES

- The flap automatically closes when the unit is off.
- During the heating operation, the fan speed will be very low and the flap will be in the horizontal position (position ④) until the air being blown out of the unit begins to warm. Once the air warms up, the flap position and fan speed change to the settings specified with the remote control.



#### CAUTION

- Use the FLAP button on the remote control to adjust the position of the flap. If you move the flap by hand, the actual flap position and the flap position on the remote control may no longer match. If this should happen, shut off the unit, wait for the flap to close, and then turn on the unit again; the flap position will now be normal again.

## OPERATION WITHOUT THE REMOTE CONTROL UNIT

If you have lost the remote control unit or it has troubles, follow the steps below.

### 1. WHEN THE AIR CONDITIONER IS STOPPED

If you want to turn on the air conditioner push the OPERATION BUTTON to select the desired mode (COOL or HEAT).

#### NOTE

The air conditioner will start in HIGH fan speed. The temperature setting is 25°C for cooling mode and 21°C for heating mode.

### 2. WHEN THE AIR CONDITIONER IS RUNNING

If you want to turn off the air conditioner push the OPERATION BUTTON until the OPERATION lamp is turned off.

#### NOTE

#### Power failure during operation.

In the event of power failure, the unit will stop. When the power is resumed, the unit will restart automatically after 3 minutes.

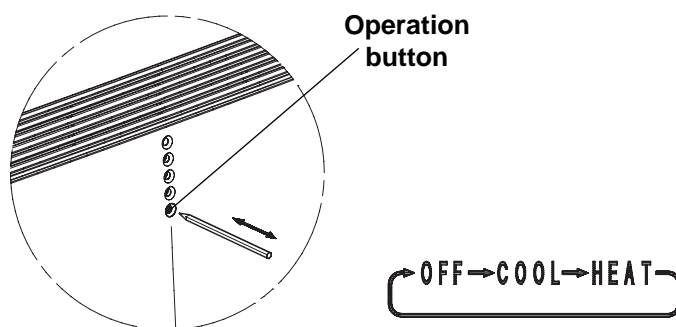

## TIPS FOR ENERGY SAVING

### DO NOT:

- Block the air intake and outlet of the unit. If they are obstructed, the unit will not work well, and may be damaged.
- Let direct sunlight into the room. Use sunshades, blind or curtain.

### DO:

- Always try to keep the air filter clean. A clogged filter will impair the performance of the unit.
- To prevent conditioned air from escaping, keep windows, doors and any other openings closed.

## TROUBLESHOOTING



### WARNING

- The use of portable telephones near the air conditioner may cause disturbance to its normal operation and must be avoided. In case abnormal operation is noticed, (OPERATION lamp lights, but the air conditioner will not run) to restore normal operation turn-off electric supply for about 3 minutes, by disconnecting the main switch or the wall plug, then start again the air conditioner.

- If your air conditioner does not work properly, first check the following points before requesting service. If it still does not work properly, contact your dealer or service centre.

**Trouble:** the air conditioner does not run at all.

**Possible cause:**

- Power failure.
- Leakage breaker tripped.
- Operation button is OFF.
- Batteries in remote control unit have run down.

**Remedy:**

- Restore power.
- Contact service centre.
- Press the button again.
- Replace batteries.

**Trouble:** Poor cooling or heating performance.

**Possible cause:**

- Dirty or clogged air filters.
- Heat source or many people in room.
- Doors and/or windows are open.
- Obstacle near air intake or air discharge port.
- The set temperature on the remote control unit is too high.
- Outdoor temperature is too low (heat pump version).

**Remedy:**

- Clean air filters to improve airflow.
- Eliminate heat source if possible.
- Shut them to keep the heat or cold out.
- Remove it to ensure good airflow.
- Set the right temperature on the remote control unit.
- Try to use a back-up heater.

**Trouble:** Clicking sound is heard from the air conditioner.

**Possible cause:**

- During operation, any plastic parts may expand or shrink due to a sudden temperature change. In this event, a clicking sound may occur.

**Remedy:**

- This is normal, and the sound will disappear when an even temperature is settled.

**Trouble:** The electrical heating does not run.

**Possible cause:**

- The required temperature is too low.
- The electrical heater has not been activated.

**Remedy:**

- Set an higher temperature on the remote control.
- Activate the electrical heater pressing the FILTER button of the remote control (only during HEATING and FAN mode).

## AUTO-DIAGNOSIS

STANDBY	LEDS		POSSIBLE CAUSE
	OPERATION	TIMER	
F	F	O	Defective indoor air sensor
F	F	●	Defective outdoor air sensor
O	F	F	Defective indoor air coil sensor
●	F	F	Defective outdoor air coil sensor
F	O	O	Defective compressor discharge temperature sensor
F	●	O	Malfunctioning of electronic PCB (current protection)
F	O	●	Malfunctioning of electronic PCB (temperature protection)
F	●	●	Malfunctioning of PFC (power factor correction system)
O	F	O	Malfunctioning of the condensate drainage system

O = LED OFF

● = LED ON

F = Flashing LED

## HOW TO DISCHARGE THE CONDENSATE WATER

The Humidity removed by the unit is collected and discharged automatically, but in special conditions some condensate water could remain inside the unit.

If you are not going to make use of the air conditioner for a long period, it is necessary to discharge the eventual condensate water through the service tube for condensate discharge placed under the bottom of the unit.

### IMPORTANT

At the end of the operation close the tube with its stopper.



### WARNING

- Always switch off the air conditioner before unplugging it from the power socket.
- Always unplug the air conditioner before discharging the condensate water collected inside.

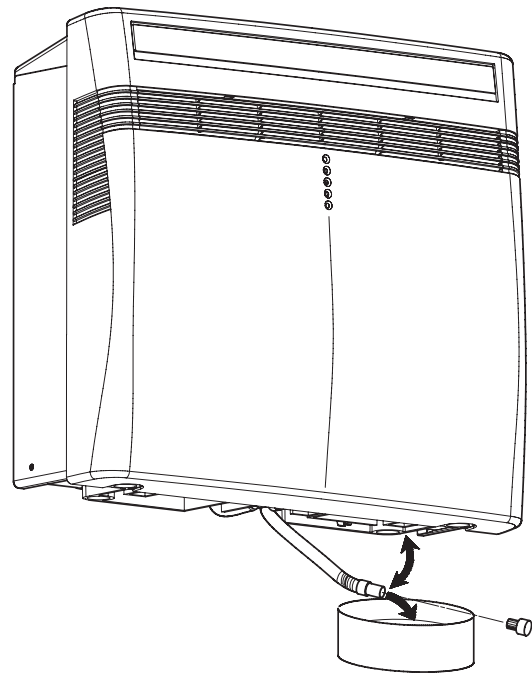

EG

## CARE AND CLEANING

**WARNING!** For safety's sake, be sure to turn the air conditioner OFF and also disconnect it from the power supply before cleaning it.

### 1. Cleaning of the Air Filter

The air filter must be checked at least once every two weeks operation. Operation with a dirty filter always causes a lower efficiency of the air conditioner and severe product damage. The filter is located at the back of the front intake grille: open the grille pulling downward the two hooks, grasp the air filter and pull upwards. Use a vacuum cleaner to remove light dust. If there is sticky dust on the filter, wash it with lukewarm soapy water, then rinse in clean, cold water and dry it before reinstallation.

### 2. Cleaning of Casing and Grilles.

To clean the air conditioner, wipe it with a clean soft cloth, lightly moistened. In case it is stained, moisten the cloth with soapy water. Never use solvents or harsh chemicals, nor very hot water. Do not pour water over the air conditioner to clean it: this will damage the internal components and cause an electric shock hazard.

### 3. After use.

If you are not going to make use of the air conditioner for a long period, clean the air filter and verify that there is no condensate water inside the bottom of the unit (see paragraph "HOW TO DISCHARGE THE CONDENSATE WATER"). Do not put heavy objects on top of the unit.

### 4. Transport.

Keep the air conditioner in the vertical position during transportation.

5. **For your safety care check periodically the conditions of the electric supply cable; the electrical connection of the unit is Y type with cable prepared in a special way; in case you should notice any damage due to usage, call the nearest After Sale Service to get the cable replaced.**

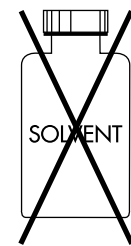
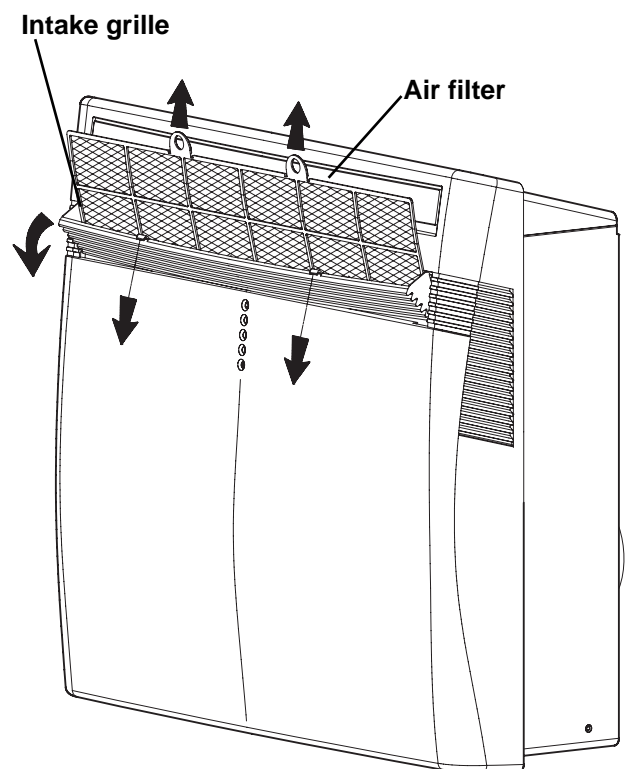

NO!

**Electric wiring diagrams' symbols / Simboli schemi elettrici / Symboles des schemas électriques  
Symbole der System-Schaltplanen / Συμβόλων Ηλεκτρικού Διαγράμματος ΤΩΝ ΣΥΣΤΗΜΑΤΩΝ**

SYMBOL	EG	I	F	D	E	P	GR
PC-DP	CONDENSATE PUMP MOTOR	MOTORE POMPA CONDENSA	MOTEUR POMPE CONDENSATION	KONDENSIWASSERPUMPE-MOTOR	MOTOR BOMBA DE AGUA	MOTOR BOMBA DE AGUA	ΑΝΤΛΙΑ ΑΠΟΣΤΡΑΓΓΙΣΗΣ
CM	COMPRESSOR MOTOR	MOTORE COMPRESSORE	MOTEUR DE COMPRESSEUR	KOMPRESSORMOTOR	MOTOR DEL COMPRESOR	COMPRESSOR	ΣΥΜΠΙΕΣΤΗΣ
C1, 2, 3, 4	CAPACITOR	CONDENSATORE	CONDENSATEUR	KONDENSATOR	CONDENSADOR	CONDENSADOR	ΣΥΜΠΥΚΝΩΤΗΣ
DEF THERMO	DEFROST THERMOSTAT	TERMOSTATO SBRINATORE	THERMOSTAT DE DEGRIVAGE	ENTFROSTER-THERMOSTAT	TERMOSTATO DE DESCONGELACION	TERMOSTATO DE DESCONGELACION	ΘΕΡΜΟΣΤΑΤΗΣ ΑΠΟΥΥΞΗΣ
FLP	FLAP MOTOR	MOTORE DEFFETTORE	MOTEUR DE VOLET	KLAPPENMOTOR	MOTOR DEL DEFLECTOR	MOTOR DA PLACA	ΚΙΝΗΤΗΡΑΣ ΕΚΠΡΟΤΗΣ
LM	LOUVER MOTOR	MOTORE DEFFETTORE	MOTEUR D'AUVENT	LUFTKLAPPENMOTOR	MOTOR CON ABERTURAS	MOTOR COM ABERTURAS LATERAIS	ΚΙΝΗΤΗΡΑΣ ΕΚΠΡΟΤΗΣ
FMO	OUTDOOR FAN MOTOR	MOTORE ESTERNO VENTOLA	MOTEUR DE VENTILATEUR EXTERIEUR	AUSSENLUFTERMOTOR	MOTOR EXTERIOR DE LA TURBINA	MOTOR DA VENTONHA EXTERIOR	ΕΞΩΤΕΡΙΚΟΣ ΑΝΕΜΙΣΤΗΡΑΣ
FMI, FM	INDOOR FAN MOTOR	MOTORE INTERNO VENTOLA	MOTEUR DE VENTILATEUR INTERIEUR	INNENLUFTERMOTOR	MOTOR INTERIOR DE LA TURBINA	MOTOR DA VENTONHA INTERIOR	ΕΣΩΤΕΡΙΚΟΣ ΑΝΕΜΙΣΤΗΡΑΣ
IND. ASSY	INDICATOR ASSY	GRUPPO INDICATORI	ENSEMBLE INDICATEUR	ANZEIGE-BAUGRUPPE	GRUPO DE INDICADORES	GRUPO DE INDICADORES	ΣΕΤ ΕΝΔΕΙΚΤΙΚΟΥ
MG	MAGNETIC CONTACTOR	CONTACTTORE MAGNETICO	CONTACTEUR MAGNETIQUE	MAGNETKONTGEBER	CONTACTOR MAGNETICO	CONTACTOR MAGNETICO	ΣΥΣΤΗΜΑ ΜΑΓΝΗΤΙΚΩΝ ΕΠΙΦΑΝ
NF	NOISE FILTER	FILTRO RUMORE	FILTRE ANTI PARASSITE	LÄRM-SCHUTZFILTER	FILTRO DEL RUIDO	FILTRO DE RUIDO	ΦΙΛΤΡΟ ΘΟΥΡΒΟΥ
OLR	OVERLOAD RELAY	RELÉ SOVRACCARICO	RELAIS DE SURCHARGE	ÜBERLASTRELAIS	RELÉ DE SOBRECARGA	RELÉ DE SOBRECARGA	ΡΕΛΕ ΥΠΕΡΦΟΡΤΩΣΗΣ
CE-PCB	CONTROLLER	SCHEDA ELETTRICA	CARTE ELECTRONIQUE	STEUERGERÄT	CONTROLADOR	PANEL ELÉTRICO	ΕΛΕΓΚΤΗΣ
PR	POWER RELAY	RELÉ ALIMENTAZIONE	RELAIS D'ALIMENTATION	LEISTUNG-SRELAIS	RELÉ DE ALIMENTACIÓN	RELÉ DA ALIMENTAÇÃO	ΡΕΛΕ ΕΣΧΥΟΣ
RP	PUMP RELAY	RELÉ POMPA	RELAIS POMPE	PUMPE RELAIS	RELÉ BOMBA DE AGUA	RELÉ BOMBA	ΡΕΛΕ ΑΝΤΛΙΑ
SSR	SOLID STATE RELAY	RELÉ STATO SOLIDO	RELAIS A SEMI-CONDUCTEUR	FESTKÖRPERRELAIS	RELÉ DEL ESTADO SÓLIDO	RELÉ DO ESTADO SÓLIDO	ΡΕΛΕ ΣΤΕΡΕΗΣ ΚΑΤΑΣΤΑΣΗΣ
RA	STARTING RELAY	RELÉ D'AVVAMENTO	RELAIS DE DEMARRAGE	STARTRELAIS	RELÉ DE ARRANQUE	RELÉ DE ARRANQUE	ΡΕΛΕ ΕΚΚΙΝΕΤΣ
SV	SOLENOID VALVE	VALVOLA SOLENOIDE	ELECTROVANNE	MAGNETVENTIL	VÁLVULA SOLENOIDE	VÁLVULA SOLENOIDE	ΣΩΛΗΝΟΕΙΔΗΣ ΒΑΒΛΙΔΑ
MS-FS	SAFETY FLOAT SWITCH	INT. SICUREZZA A GALL.	INTERR. DE SECURITE A FLOTTEUR	SCHWIMM-SCHUTZSCHALTER	INTERR. DE SEGURIDAD DE FLOTADOR	INTERR. DE SEGURANÇA	ΔΙΑΚΟΠΤΗΣ ΑΣΦΑΛΕΙΑΣ ΜΕ ΠΛΩΤΗΡΑ
ON-OFF SW	ON-OFF SWITCH	INTERRUITTORE MARCIA/ARRESTO	TOUCHE MARCHÉ/ARRÊT	ENQUIS TASTE	BOTON ARRANQUE/PARADA	INTERRUPTOR LIGAR/DESLLGAR	ΔΙΑΚΟΠΤΗΣ ΚΙΝΗΣΗΣ/ΣΤΑΜΑΤΗΜΑΤΟΣ
TH1, 2,	THERMISTOR	TERMISTORE	THERMISTANCE	THERMISTOR	TERMISTOR	TERMISTOR	ΘΕΡΜΟΣΤΑΤΗΣ
P	TIMER	PROGRAMMATTORE	PROGRAMMATEUR	ZEITSCHALT-UHR	PROGRAMADOR	TIMER	ΠΡΟΓΡΑΜΜΑΤΙΣΤΗΣ
TR1, 2	POWER TRANSFORMER	TRASFORMATORE DI POTENZA	TRANSFORMATEUR DE PUISSANCE	NETZTRANSFORMATOR	TRANSFORMADOR DE POTENCIA	TRANSFORMADOR DE CORRENTE	ΜΕΤΑΣΧΗΜΑΤΙΣΤΗΣ ΙΣΧΥΟΣ
20S	4-WAY VALVE	VALVOLA 4 VIE	VANNE 4 VOIES	4-WEG-VENTIL	VÁLVULA DE 4 VÍAS	VÁLVULA DE 4 VIAS	ΒΑΒΛΙΔΑ 4 ΔΙΕΥΘΥΝΣΕΩΝ
4TC	NEGATIVE PHASE RELAY	RELÉ A FASE NEGATIVA	RELAIS D'ORDRE DE PHASE	NEGATIVPHASENRELAIS	RELÉ DE FASE NEGATIVA	RELÉ DA FASE NEGATIVA	ΡΕΛΕ ΑΡΗΘΙΚΗΣ ΦΑΣΗΣ
HWC	HOT WATER CONTROL	SCHEDA CONTROLLO ACQUA CALDA	CARTE ELECTRONIQUE EAU CHAUDE	WARMWASSER-STEUERGERÄT	CONTROLADOR AGUA CALIENTE	PLACA DE CONTROL AGUA QUENTE	ΚΑΡΤΑ ΕΛΕΓΧΟΥ ΖΕΣΤΟΥ ΝΕΡΟΥ
TM	LIMIT WATER THERMOSTAT	TERMOSTATO LIMITE ACQUA	THERMOSTAT DE SEC. NIVEAU EAU	WASSERGRENZE-THERMOSTAT	TERMOSTATO LIMITE AGUA	TERMOSTATO LIMITE AGUA	ΘΕΡΜΟΣΤΑΤΗΣ ΟΡΙΟΥ ΝΕΡΟΥ
EWV	WATER ELECTRIC VALVE	ELETTROVALVOLA PASS. ACQUA	ELECTROVANNE PASSAGE EAU	VENTIL (WASSER-DURCHFLOSS)	VÁLVULA FLUO DE AGUA	VÁLVULA PASSAGEM DE AGUA	ΗΛΕΚΤΡΟΒΑΒΛΙΔΑ ΔΙΕΛΕΥΣΗΣ ΝΕΡΟΥ

	EG	I	F	D	E	P	GR
BLK	BLACK	NERO	NOIR	SCHWARZ	NEGRO	PRETO	ΜΑΥΡΟ
BLU	BLUE	BLU	BLEU	BLAU	AZUL	AZUL	ΜΠΛΕ
BRN	BROWN	MARRONE	MARRON	BRAUN	MARRÓN	CASTANHO	ΚΑΦΕ
GRN/YEL	GREEN / YELLOW	VERDE / GIALLO	VERT / JAUNE	GRÜN / GELB	VERDE / AMARILLO	VERDE / AMARELO	ΠΡΑΣΙΝΟ / ΚΙΤΡΙΝΟ
GRY	GREY	GRIGIO	GRIS	GRAU	GRIS	CINZENTO	ΓΡΥΖΟ
ORG	ORANGE	ARANCIONE	ORANGE	ORANGE	NARANJA	COR-DE-LARANJA	ΠΟΡΤΟΚΑΛΙ
PNK	PINK	ROSA	ROSE	ROSA	ROSA	COR-DE-ROSA	ΡΟΖ
RED	RED	ROSSO	ROUGE	ROT	ROJO	ENCARNADO	ΚΟΚΚΙΝΟ
VLT	VIOLET	VIOLA	VIOLET	VIOLETT	VIOLETA	VIOLETA	ΜΟΒ
WHT	WHITE	BIANCO	BLANC	WEISS	BLANCO	BRANCO	ΑΣΤΙΡΟ
YEL	YELLOW	GIALLO	JAUNE	GELB	AMARILLO	AMARELO	ΚΙΤΡΙΝΟ
AZU	LIGHT BLUE	AZZURRO	AZUR	HIMMELBLAU	AZUL CLARO	AZUL CLARO	ΓΑΛΑΖΟ

**Wires color legend**  
**Legenda colori fili elettrici**  
**Légende des couleurs des fils électriques**  
**Beschriftung der Leitungs-Farben**  
**Leyenda de los colores de los cable electricos**  
**Πίνακας χρωμάτων ηλεκτρικών καλωδίων**

**argoclima** s.p.a.

Via Varese, 90 - 21013 Gallarate - Va - Italy

Tel. +39 0331 755111 - Fax +39 0331 776240

www.argoclima.com