

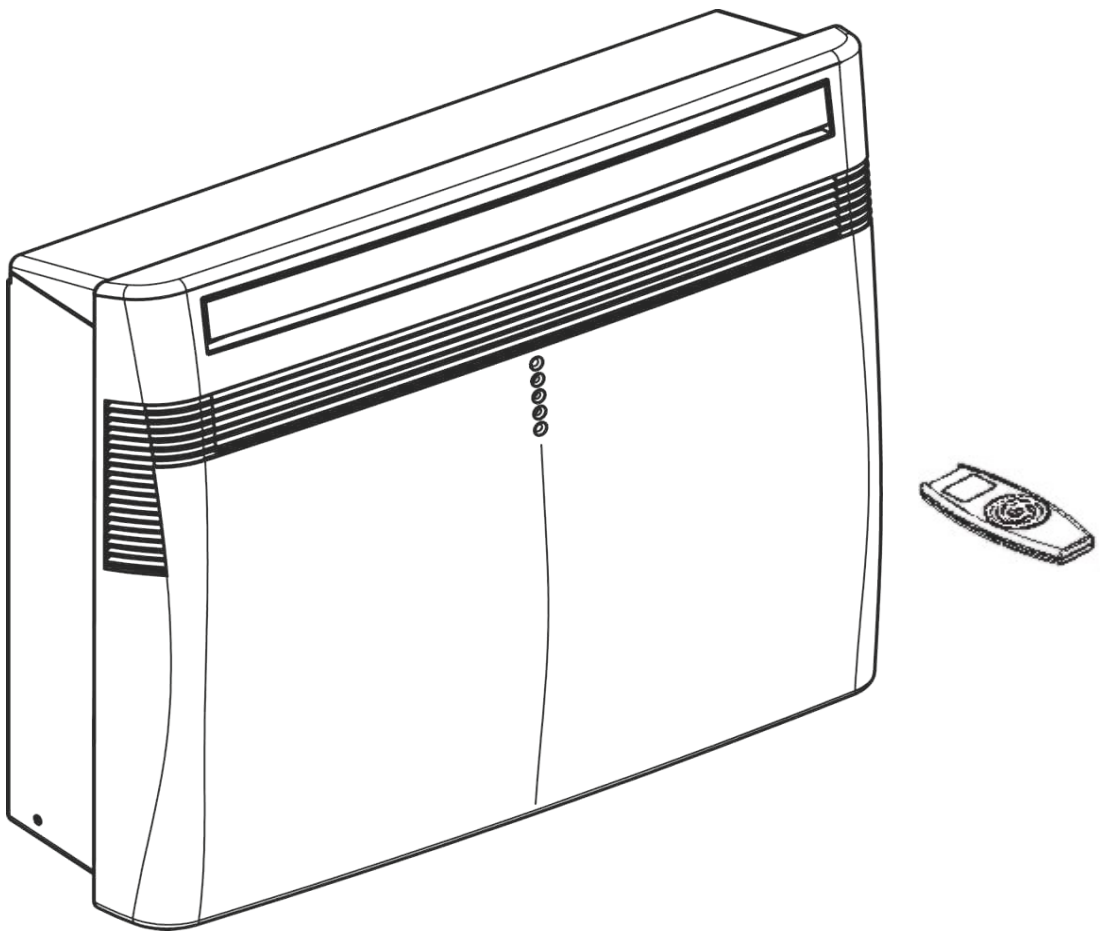

## TECHNICAL DATA & SERVICE MANUAL



**ARGO HPL/SCL**

0.8180.612.01

06/2012

# Table of contents

Page

<b>A</b>	<b>SPECIFICATIONS</b>	
	1) Unit specifications	3
	2) Major Component specifications	4
<b>B</b>	<b>OPERATING RANGE</b>	6
<b>C</b>	<b>DIMENSIONAL DATA</b>	7
<b>D</b>	<b>REFRIGERANT FLOW DIAGRAMS</b>	8
<b>E</b>	<b>FUNCTIONS</b>	
	1) System operation control	9
	2) Cool Mode Operation	9
	3) Heat Mode Operation	9
	4) Auto Mode Operation	10
	5) Dry Mode Operation	11
	6) Fan Mode Operation	11
	7) Auto Fan Speed	11
	8) Forced Mode	12
	9) Protection operations	12
	10) Defrost	14
	11) I FEEL Function	14
	12) HI POWER mode	14
	13) Heater resistance	14
	14) NIGHT Function	15
	15) LED OFF Function	15
	16) Capacity test mode	15
	17) Diagnostic	16
	18) Address	17
	19) Manual Unit Control and Led Indicators	18
	20) Drain Pump	19
	21) Safety thermostat	19
<b>F</b>	<b>ELECTRIC WIRING DIAGRAMS</b>	20
<b>G</b>	<b>TROUBLESHOOTING</b>	21
<b>H</b>	<b>CHECKING ELECTRICAL COMPONENTS</b>	
	1) Measurement of Insulation Resistance	29
	2) Checking Continuity of Fuse on PCS Ass'y	29
	3) Checking Motor Capacitor	29

## A SPECIFICATIONS

### 1) UNIT SPECIFICATIONS

UNIT MODEL		ARGO HPL/SCL	
Power source		220 - 240 V 50 Hz	
PERFORMANCES		COOLING	HEATING
Capacity (air conditioner)	BTU / h	6310	7750
	kW	1,85	2,27
Air circulation (high/med/low)		m <sup>3</sup> / h 670-540-130	
Moisture removal (high speed)	Cooling l / h	0,6	---
ELECTRICAL RATINGS			
Voltage rating		V 220 - 240	
Available voltage range		V 198 - 264	
Running Ampere (air conditioner)		A 3,2	3,2
Power input (air conditioner)		W 710	715
Power factor		0,96	0,97
C.O.P		2,61	3,17
FEATURES			
Controls / temperature control		Microprocessor / I.C. Thermostat	
Control unit		Wireless remote control unit	
Timer		ON / OFF 24 hours and program	
Fan speed (air conditioner)		3 + Auto	
Airflow direction (Indoor)	Horizontal	Manual	
	Vertical	Auto	
Air filter		Washable, easy access	
Compressor		Rotary (hermetic) DC inverter	
Refrig./Stand. Charge at shipmen		R410A	650g
Refrigerant control		Electronic expansion valve	
Power noise level (Indoor)	Air conditioner Hi/Me/Lo dB(A)	65-62-59	
Power noise level (outdoor)	Air conditioner Hi/Me/Lo dB(A)	65-63-61	
Ducts diameter ( 2pcs )		mm	162
Condensate drain system		By duct	
DIMENSIONS AND WEIGHT			
Height		mm	735
Widht		mm	839
Depht		mm	260-280
Holes diameter in the wall (2)		mm	162
Net weight		kg	49

Data can be changed without notice

#### NOTE

#### Rating conditions:

**Cooling:** outside air temp.: 35° C DB, indoor air temp.: 27° C DB, 19° C WB

**Heating:** outside air temp.: 7° C DB, 6° C WB, indoor air temp.: 20° C DB

## 2) MAJOR COMPONENT SPECIFICATIONS

UNIT MODEL		ARGO HPL/SCL
<b>CONTROLLER (PCB)</b>		
Part No.		sac dci ODU
Controls		Microprocessor
Control circuit fuse (F1)		6,3x32 - 12,5A
<b>SWITCH INDICATOR ASSY</b>		
Model		384208055
Led color		TMR : blu - STB : orange - OPR : green
<b>REMOTE CONTROL UNIT</b>		
SAC W-REM		
<b>THERMISTOR (ROOM SENSOR) TH1</b>		
Resistance (at 25° C)	kΩ	10 ± 3%
<b>THERMISTOR (INDOOR COIL SENSOR) TH2</b>		
Resistance (at 25° C)	kΩ	10 ± 5%
<b>THERMISTOR (OUTDOOR AIR SENSOR) TH3</b>		
Resistance (at 25° C)	kΩ	10 ± 5%
<b>THERMISTOR (COMP. DISCHARGE SENSOR) TH4</b>		
Resistance (at 25° C)	kΩ	10 ± 5%
<b>THERMISTOR (OUTDOOR AIR SENSOR) TH5</b>		
Resistance (at 25° C)	kΩ	10 ± 5%
<b>FAN &amp; FAN MOTOR (FMI)</b>		
Model		UF2Q-21SC5P
Number / Diameter / Length	mm	Cross-flow 1 / Ø100 / 515
No. of pole / rpm (230 V, high)		2
rpm (230 V, high/ medium/ low)		2100/ 1760 / 730
Power input (high)	W	68
Power output (high)	W	31
Coil resistance (at 25° C)	Ω	BRN-WHT: 164 ±10% WHT-VLT: 69 ±10% VLT-ORG: 33 ±10% YLW-ORG: 74 ±10% YLW-PNK: 44 ±10%
Safety device		thermal protector
Setting	Open °C	130 ± 8
	Close	79 ± 15
Run capacitor (C2)	μF	1,5
	VAC	440
<b>FAN &amp; FAN MOTOR (FMO)</b>		
Model		D2E 146 - HS99 - 99
Number / Diameter / Length	mm	Centrifugal 1 / Ø146 / 140
No. of pole / rpm (230 V)		2
rpm (230 V high/ medium/ low)		2220/ 1735/ 1345
Nominal input (high/ medium/ low)	W	167/ 118/ 104
Coil resistance (at 25° C)	Ω	BLU-BLK: 69± 5% GRY-BLK: 34± 5% WHT-GRY: 12± 5% BRN-WHT: 30± 5%
Safety device		(Internal bimetallic type)
Setting	Open °C	150 ± 5K
	Close	Autoreset
Run capacitor (C1)	μF	5
	VAC	420

UNIT MODEL		ARGO HPL/SCL
<b>COMPRESSOR (CM)</b>		Rotary ( Hermetic)
Model		UG9A090FUAJP
Nominal cooling capacity	W	2770
oil: Freol a68ES-T or SUNICE T-68	cc	320
Coil resistance (at 20° C)	Ω	U-V : 2.78
	Ω	V-W : 2.83
	Ω	W-U : 2.73
overload protection		software protection
thermostat           Open	°C	115°C
Close	°C	-
Operating amp. (Ambient temp. 25° C)		-
<b>PUMP RELAY (RP)</b>		
Model		H62S
Contact rating		5A - 230V
Coil supply	VAC	230
Coil resistance (20 °C)	kΩ	17,2 ± 10%
<b>POWER RELAY (PR)</b>		
Model		OMRON G4F
Contact rating		20 A - 250 V
Coil supply	VAC	12
Coil resistance (20 °C)	Ω	158 ± 10%
<b>AUTOMATIC THERMOSTAT (AT)</b>		
Model		IMIT 541873
type / switching point		LS3 / 65°C
Contact rating		15A - 250V
<b>SAFETY THERMOSTAT (ST)</b>		External
Model		IMIT 541741
type / switching point		LS1 / 85°C
Contact rating		16A - 250V
<b>4-WAY VALVE (20S)</b>		
Model		SQ-136 (Coil)    SHF-4H-23U (Valve)
Coil rating		AC 220/240 V, 50 Hz, 6W
Coil resistance		1440 ± 5%
<b>ELECTRONIC EXPANSION VALVE (EEV)</b>		
Model		ZCAM-MD12EX(Coil)    ZCAM-BD15EX (Valve)
Coil rating		DC 12 V
Coil resistance		46 ± 4%
<b>ELECTRICAL HEATER (RE)</b>		
Model		05050A1
voltage	V	230
power	W	800 (+5% -10%)
resistance	Ω (at 20°C)	66 (-5% +10%)
<b>SAFETY FLOAT SWITCH (FS)</b>		
Model		P200AC-001
contact rating	V	230 Vac - 0,4 A
<b>EMI FILTER (EF)</b>		
Model		10SS4-1BA2-BR-Q2
rating voltage		115/230 Vac , 50/60Hz
rating current	A (rms)	10
<b>INDUCTOR</b>		
Model		CBMF374125
Inductance	mH	1.68 ± 10%
rating current	A	10
resistance	Ω (at 20°C)	0.13 ± 10%

UNIT MODEL		ARGO HPL/SCL
<b>CONDENSATE PUMP (PC)</b>		
Model		291036
Rating		220-240VAC~50Hz
Nominal input		5W - 0,05A
Coil resistance (at 20° C)	Ω	778 ± 8%
<b>FLAP MOTOR (FLP)</b>		
Type		Stepping motor
Model		MP24GA1
Rating		DC 12V
Coil resistance (Ambient temp. 25°C)	Ω	WHT-BLU (respectively 4 wires) : 380 ± 7%
<b>HEAT EXCHANGER COIL (EVAPORATOR)</b>		
Coil		Aluminium plate fin / copper tube
Rows		4
Fin pitch	mm	1,3
Face area	m <sup>2</sup>	0,107
<b>HEAT EXCHANGER COIL (CONDENSER)</b>		
Coil		Aluminium plate fin / copper tube
Rows		4
Fin pitch	mm	1,3
Face area	m <sup>2</sup>	0,111
<b>THERMOSTATIC VALVE DRAIN PAN</b>		
Model		DP 25-1101-07 or DP 25-1107-01
Open	°C	4,4
Close	°C	15,5
Stroke	mm	5,1

## B OPERATING RANGE

	Temperature	Indoor air intake temp.	Outdoor air intake temp.
Cooling	Maximum	32° C DB/ 23° C WB	43° C DB
	Minimum	10° C DB/ 6° C WB	-15° C DB
Heating	Maximum	27° C DB	24° C DB / 18° C WB
	Minimum	indoor room 30% R.H.	-15° C DB
Dry	Maximum	32° C BS/ 80% R.H.	43° C DB
	Minimum	10° C BS/ 80% R.H.	-15° C DB

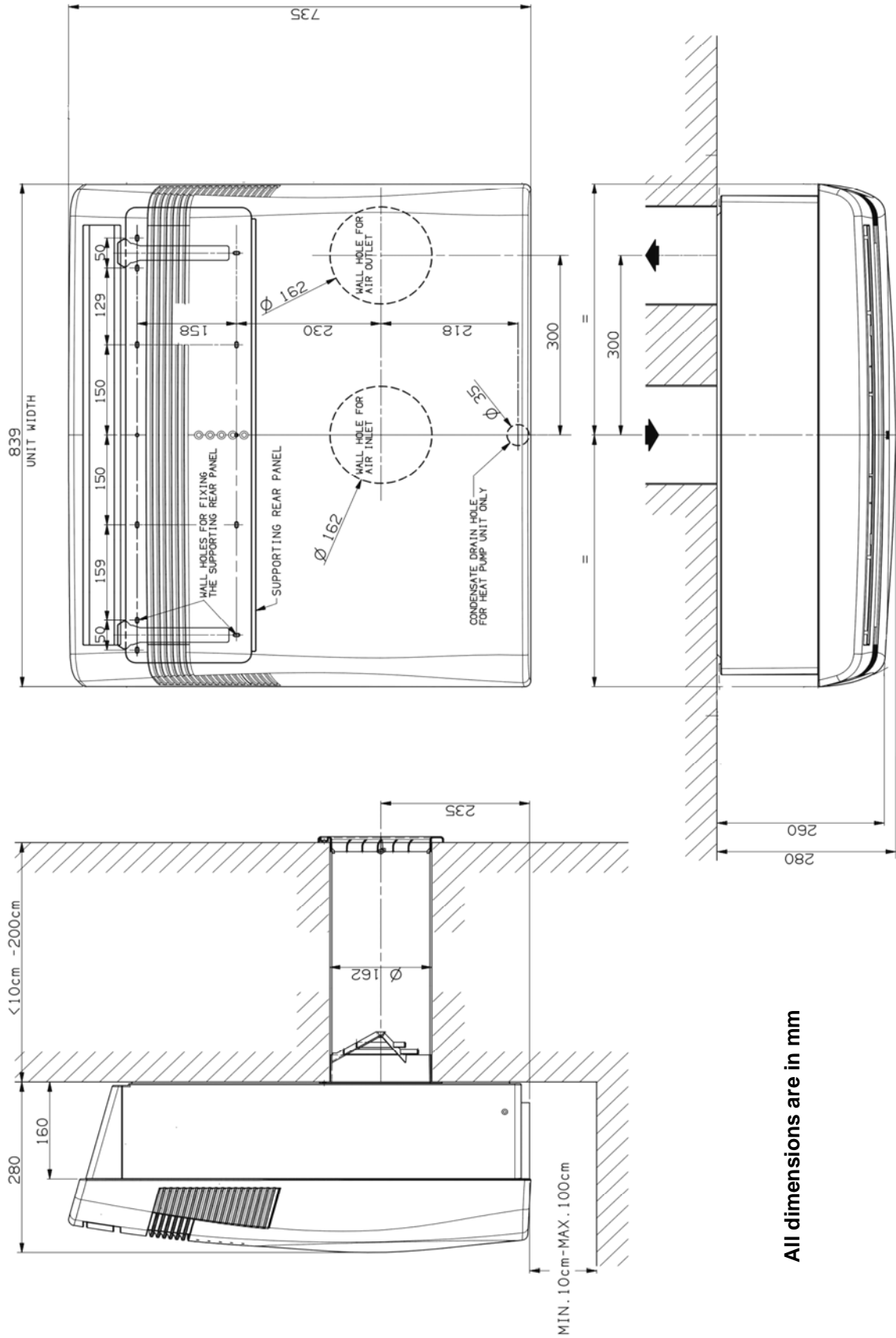

All dimensions are in mm

**D REFRIGERANT FLOW DIAGRAM**

**ARGO HPL/SCL**

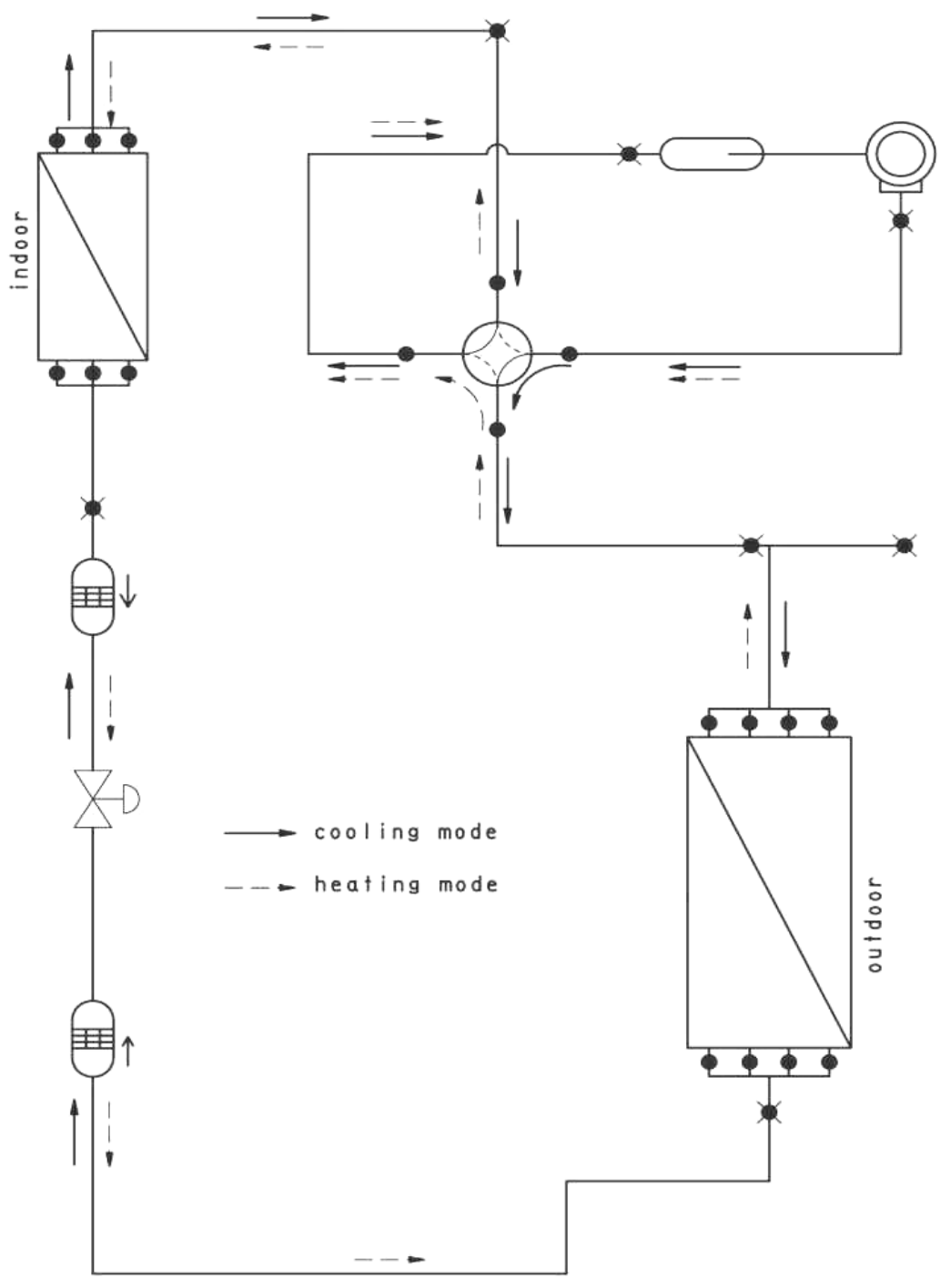



## 1 System operation control

The units receives the user input (fan speed, flap position etc) through remote controller which sends signal every time a button is pressed and in any case, automatically, every 5 minutes.

During operation compressor speed can be subjected to change due to thermal load variations or protection activations but in any case:

- The minimum time interval between an OFF and a ON operation is not lower than 3 minutes
- The minimum operating time is not lower than 3 minutes
- The maximum acceleration/deceleration rate is fixed at 20rpm /sec
- During the start-up compressor speed increases according to a defined rule which is independent from the thermal load calculation.

## 2 Cool Mode Operation

In Cooling Mode, the operation of the compressor (CM), Outdoor Fan (FMO) and Indoor Fan (FMI) are determined by:

- 1) the difference between the room air temperature (RAT) and the set point temperature (SPT)
- 2) the protection level at which the system is operating
- 3) the thermal load in the room

### NOTES

In addition to the temperature difference of above, the operation of the main components (CM, FMO, FMI) is also controlled by protection function.

The minimum off time of compressor is 3 minutes.

The indoor fan can change speed only after it has operated at the same speed for 30 sec if in AUTO and 1 sec for the other settings (High, Med, Low).

## 3 Heat Mode Operation

The Heating mode operation is similar to the Cooling mode operation. The CM, FMO and FMI are controlled by the same parameters.

The FMI will not be turned on until the indoor coil temperature is warm enough to prevent the supply of cold air (see COLD DRAFT PREVENTION feature for details).

The indoor fan can change speed only after it has operated at the same speed for 30 sec if in AUTO and 1 sec for the other settings (High, Med, Low).

## 4 Auto Mode Operation

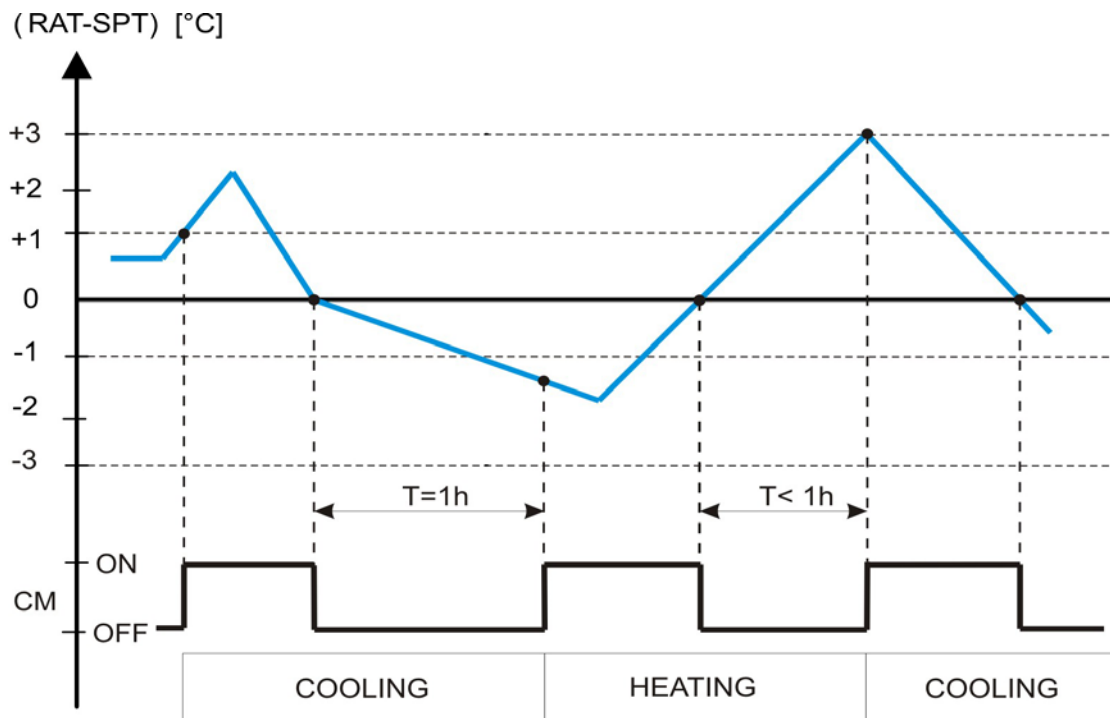

In Auto Mode, the unit switches automatically between the Auto Cooling and Auto Heating in order to maintain the room temperature (RAT) at the prescribed set point (SPT).

The switching between the two modes is according to the above graph and following table

COOLING ---> HEATING
If $-3^{\circ}\text{C} \leq \text{Dt} \leq -1^{\circ}\text{C}$ and the compressor is off for more than 1 hour
If $\text{Dt} \leq -3^{\circ}\text{C}$ and compressor is off for more than 3 minutes
HEATING ---> COOLING
If $1^{\circ}\text{C} \leq \text{Dt} \leq 3^{\circ}\text{C}$ and the compressor is off for more than 1 hour
If $\text{Dt} \geq 3^{\circ}\text{C}$ and compressor is off for more than 3 minutes

$\text{Dt} = \text{RAT} - \text{SPT}$

Refer to the sections 1 COOLING MODE and 2 HEATING MODE for system operation details.

## 5 Dry Mode Operation

Dry operation remove moisture from indoor air running, in cooling mode, at a low level without reducing the ambient temperature. This is done cycling ON and OFF the unit according to table below.

ROOM TEMP	DRY LEVEL	
$\geq \text{SPT}+2^{\circ}\text{C}$	LEVEL 0	Operation according to COOLING mode
$< \text{SPT}+2^{\circ}\text{C}$ $\geq \text{SPT}-1^{\circ}\text{C}$	LEVEL 1	CM on at constant speed FMO on at constant speed FMI switches between L and OFF every 30 seconds RV off
$< \text{SPT}-1^{\circ}\text{C}$ $\geq 15^{\circ}\text{C}$	LEVEL 2	CM switches 9 minutes off and 3 minutes on FMO switches 9 minutes off and 3 minutes ON FMI switches between L and OFF every 30 seconds RV off
$< 15^{\circ}\text{C}$	DRY OFF ZONE	CM off FMO off FMI off RV off

SPT = Set Point Temperature

## 6 Fan Mode Operation

With this mode, the indoor fan is turned on while CM and FMO stay off all the time. The user can select between 3 speeds: HIGH, MEDIUM and LOW.

## 7 Auto Fan speed

With this option selected, the indoor fan speed changes automatically according to the compressor speed as shown in the following graphs

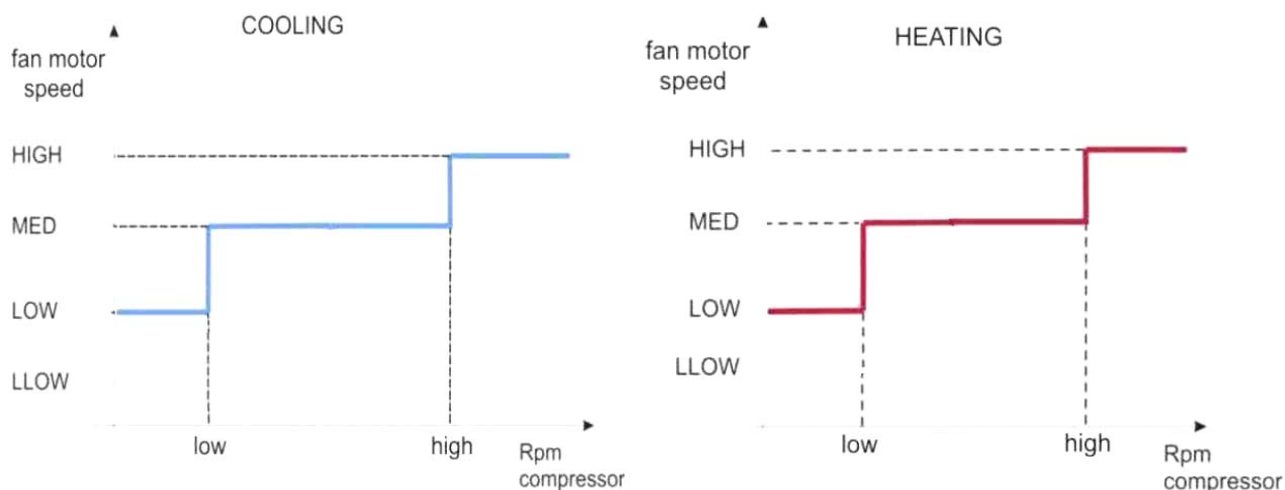

In heating, to prevent the supply of cool air, the FMI speed is set as shown only if the indoor coil temperature ICT  $\geq 34^{\circ}\text{C}$  ( see COLD DRAFT PREVENTION feature for details )  
If RAT goes over SET POINT by  $1^{\circ}\text{C}$  or less, for 1 hour, FMI is forced to LOW. If after 1 hour, RAT is still over SPT, FMI and compressor switch off.

## 8 Forced Mode

In this mode the system operates (COOLING or HEATING mode – fixed settings) or is switched off by means of the MODE button on the pcb receiver. The operation modes can be selected pressing the button in a cyclic way (OFF ⇒ COOL ⇒ HEAT ⇒ OFF...). The settings are:

### COOLING mode

SET POINT temperature = 25°C

FAN SPEED = HIGH

FLAP POSITION = 3

### HEATING mode

SET POINT temperature = 21°C

FAN SPEED = HIGH

FLAP POSITION = 4

This special mode is useful if the remote controller is missing or unusable.

When the remote controller operates, the function is automatically set off and the air conditioner follows the remote controller instructions

## 9 Protection operations

### 9.1 Freeze-up

This protection prevents ice formation on the indoor coil heat exchanger. The protection is activated as soon as the indoor coil temperature ICT decreases and acts by decreasing the compressor speed

The system exit this protection routine when ICT temperature rises above 5°C.

### 9.2 Cold draft

This feature prevents the supply of cold air forcing the indoor fan to a speed which cannot be changed by the user.

If the ICT temperature goes down 32°C (in descending) or does not reach 37°C (in rising), the speed fan is set as shown below.

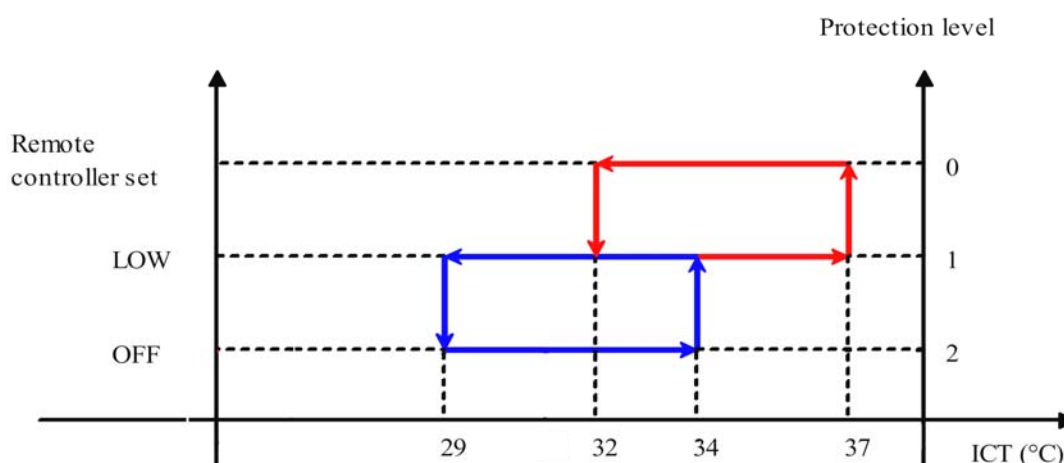

### 9.3 Overheat internal exchanger

This feature prevents the build up of high pressure in the indoor heat exchanger during heating operation. As soon as the indoor coil temperature (ICT) increases, compressor speed is reduced in order to avoid heat exchanger overheating. System stops compressor operation when ICT reaches 60 °C

#### **9.4 Overheat outdoor exchanger**

During cooling operation as soon as the outdoor coil temperature (OCT) increases, compressor speed is reduced in order to avoid heat exchanger overheating. System stops compressor operation when OCT reaches 65 °C

#### **9.5 Compressor discharge temperature**

During operation, as soon as the discharge temperature increases, (CDT) compressor speed is reduced in order to avoid overheating of the motor. Compressor is stopped when CDT reaches 111°C

#### **9.6 Compressor power-module overheating**

The module temperature, detected by a built-in thermistor, is always monitored by the control system and kept operating in a safe area. If temperature exceeds 100°C, operation is automatically stopped.

#### **9.7 Compressor power-module overcurrent**

Operation is automatically stopped in case of current driven to each motor phase greater than 9A

## 10 Defrost

The defrost process is controlled by a detection algorithm designed in order to maintain optimal utilization of the heat pump capacity especially during negative outdoor temperature conditions.

- Compressor speed fixed
- Expansion valve opening fixed
- Outdoor fan switched off
- Indoor fan controlled by cold draft prevention
- Reversing valve switched off (cooling operation)
- Minimum defrost time interval is 6 minutes
- During HIGH POWER operation the defrost detection is ignored until this mode remains active
- System exits defrost protection at least after 6 minutes and only if the temperature of 14°C is reached on outdoor coil. In any case it exits if at least 12 minutes are elapsed from the start of the defrost cycle.
- After defrost, the compressor starts run after 3 minutes although the fan and the resistance switch on after 45 seconds.

## 11 I FEEL function

As standard configuration the air conditioner operates detecting the room temperature through the sensor equipped in the wireless remote controller (icon I FEEL shown on the display). This feature provides a personalised environment since the temperature can be detected where the remote controller is located. It is possible to de-activate this option pressing the I FEEL button on the remote controller. In this case the I FEEL icon is no longer displayed and room temperature is detected through the sensor included in the indoor unit.

## 12 HI POWER mode

When this mode is active the air conditioner operates without any power limitation. The compressor can use the full range of speed. During this mode, the operation led blinks with a long intermittence.

To reset to normal mode (ECO mode), press three times the HI POWER / NIGHT MODE button on remote controller. After this switch, check that the operation lamp is constantly on.

## 13 Heater resistance

The unit is equipped with a heater resistance which provides auxiliary power if required. There are 3 modes for heater operation:

### 13.1 Automode

The heater resistance switches on only when the following conditions are satisfied:

- 1) unit in automode operation
- 2) the required thermal load is higher than the maximum power that can be supplied by the heat pump circuit
- 3) outdoor air temperature lower than 2°C (OAT < 2°C)

### 13.2 Auxiliary power in heating

The heater resistance will switch on upon request of the user, in heating mode operation, by pressing the FILTER button on remote controller (icon FILTER shown on the display)

### 13.3 Fan heater

In fan mode operation, the heater resistance will switch on, upon request of the user, by pressing the FILTER button on remote controller (icon FILTER shown on the display)

In any case, the resistance will be turned off if it reaches the switching point of thermostats.

## 14 NIGHT Function

When this setting is active indoor fan speed is automatically reduced in order to allow low noise operation. Temperature control acts in the same way as NORMAL MODE but after 60 minutes of operation the air conditioner modifies automatically the set-point temperature according to the following:

- COOLING/DRY: +1°C
- HEATING: - 2°C

## 15 LED OFF function

This is a special function mode which can be selected by the user. With this option active the OPERATION, TIMER and STANDBY lamps are switched off even during operation (they activates only in case of diagnostic signaling).

Before setting this mode, ensure that the icon 'FILTER' is not shown on display of remote controller and pressing, at the same for more than 5 seconds the IFEEL and FAN buttons

To reset the normal lamps signaling, press at the same for more than 5 seconds the IFEEL and FAN buttons

## 16 Capacity Test mode

This is a special operating mode used when testing the performance of the A/C. In this case the main components of the A/C (compressor , outdoor fan, indoor fan) operate at fixed settings.

This option is activated by setting the remote controller as follows:

- select filter on
- select high power on
- set the mode and temperature based on which kind of test is needed

COOLING MODE: Setpoint = 10°C

HEATING MODE: Setpoint = 32°C

- press at the same time for more than 5 seconds IFEEL and FAN buttons

In cooling capacity test mode the TIMER lamp blinks while the OPERATION lamp is on

In heating capacity test mode the TIMER lamp blinks while the STANDBY lamp is on

To reset the unit to normal mode, just turn off the power supply of the unit for at least 1 minute.

## 17 Diagnostic

With this feature it is possible to have a visual signal that a trouble is occurring. This mode is always active and the signalling is made through the display board LEDs. In case of no troubles the LEDs status follows its normal function. The detected troubles are showed to the user/technician using the 3 LEDs of the receiver. For each fault there are different effects upon the operation of the A/C:

### NOTES

- The troubles are shown according to a priority list that is, in case of more than one trouble present, is always showed, at first, the one with the highest priority (1 ⇔ 2 ⇔ 3 etc).
- Sensor damaged means a situation where sensor is short-circuited or opened.
- In case of damaged sensors, the system (CM, FMO, FMI etc), if in OFF state, does not start.

Priority	FAULT	LEDS status			Effects
		LD1(tmr) blu	LD2(stby) org	LD3(opr) grn	
9	RAT probe damaged	O	F	F	System does not operate in cool, dry and heat mode*. As soon as fault is cleared, system automatically restarts after 3 minutes. During this time, the signalling is showed.
8	OAT probe damaged	●	F	F	
7	ICT probe damaged	F	O	F	
6	OCT probe damaged	F	●	F	
5	CDT probe damaged	O	F	O	
4	Compress. overcurrent	O	F	●	
3	Compressor overtemp.	●	F	O	
2	PFC fault	●	F	●	
1	Water level alarm	O	O	F	See paragraph 20. DRAIN PUMP

O = LED off  
 F = LED blinking  
 ● = LED on

\* If a fault occurred, the unit can operate only in fan and fan heater mode. In these modes, the fault signalling is suspended.



## 18 Address

### Changing the Address of the Air Conditioner

In case of more than one air conditioner operating in the same room, it may be necessary to assign an address to each unit in order to avoid operation conflicts. Address is set acting on jumpers located on the unit PCB and on dip-switches of the remote controller. The PCB settings must match the corresponding ones on the wireless remote controller

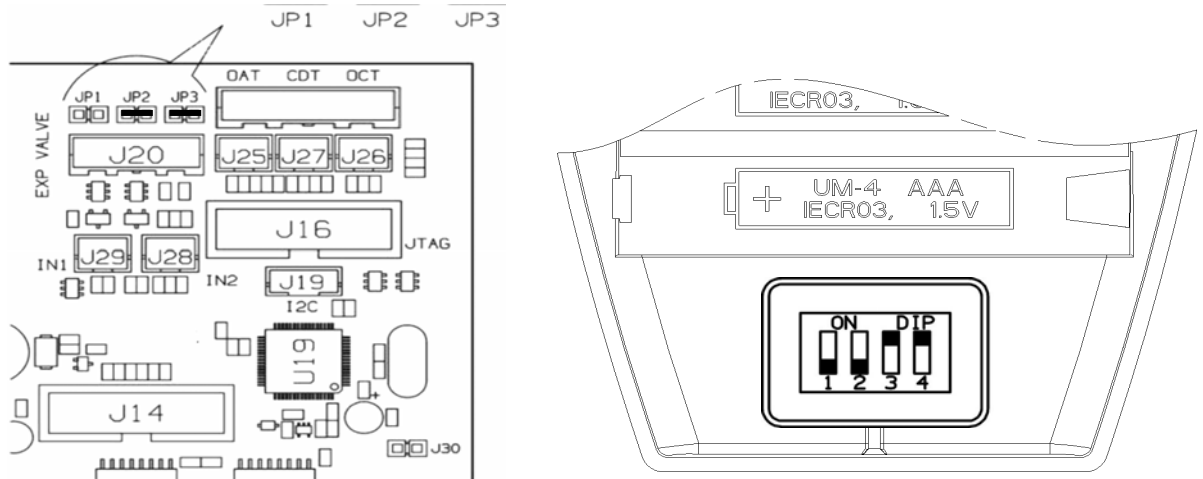

### How to change address of the air conditioner

Dip switch is located on the battery compartment.

- 1) Pull out the door and remove the batteries.
- 2) Set the switch SW1, SW2 and jumpers on PCB according to the table below (do not act on SW3 and SW4)
- 3) Insert the batteries and pull on the door

As default switches SW1 and SW2 are in off status (remote controller factory state).

UNIT ADDRESS	JUMPERS (PCB)			DIP SWITCH (REMOCON)			
	JP 1	JP2	JP3	1	2	3	4
1	open	closed	closed	off	off	on	on
2	open	open	closed	on	off	on	on
3	open	closed	open	off	on	on	on
4	open	open	open	on	on	on	on

As default switches SW1 and SW2 are in off status (PCB factory state).

## 19 Manual Unit Control and LED indicators

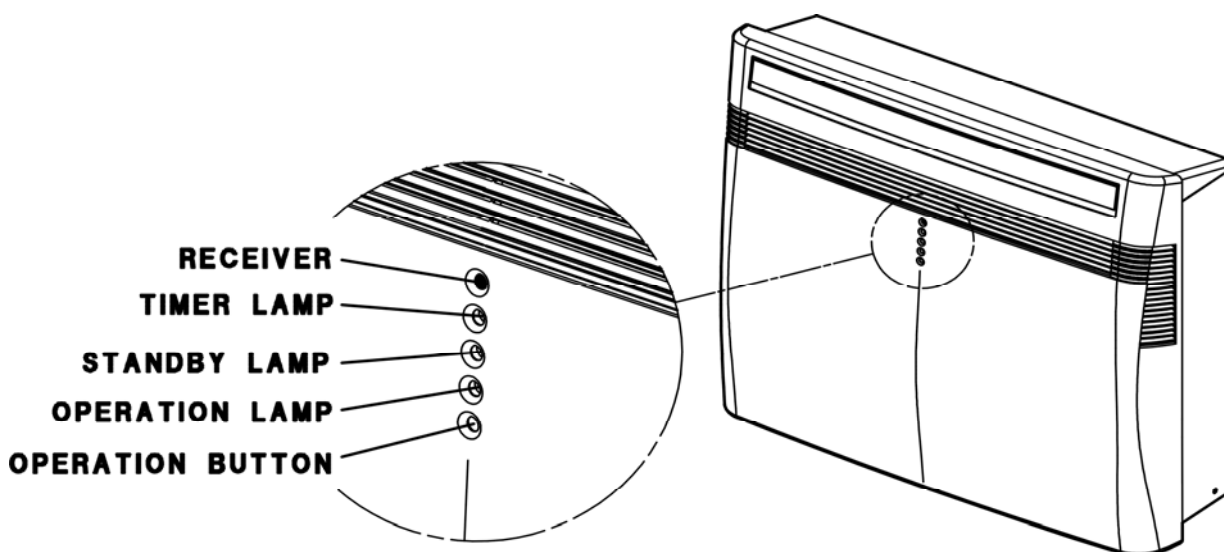

The push button switch and the LED indicators on display panel let the user to control the unit operation without a R/C (Remote Controller). Their operations are provided below.

Push Button Switch :

OPERATION BUTTON	<p>Use to cycle the operation mode of the A/C unit among COOL, HEAT and OFF modes, without using the R/C.</p> <p>Every time this switch is pressed, the next operation mode is selected, in order:</p> <ul style="list-style-type: none"> <li>- Off =&gt; Cool mode =&gt; Heat mode =&gt; Off =&gt; ... (for heat pump model)</li> <li>- The A/C will start in High fan speed.</li> </ul> <p>The temperature setting is 25°C for cooling and 21°C for heating mode.</p>
---------------------	---

**WARNING:**

the OFF position does not disconnect the power. Use the main power switch to turn off power completely.

Led indicators :

TIMER LAMP	1. Lights up during Timer operation.
STANDBY LAMP	1. Lights up when the Air conditioner is connected to the power line and ready to receive the Remote Control command. 2. Blinks in combination with the other lamps in case of faults (see diagnostic paragraph)
OPERATION LAMP	1. Lights up in Operation mode. 2. Blinks in combination with the other lamps in case of faults (see diagnostic paragraph)

## 20 Drain pump

Pump operates when the unit is running in COOLING and DRY modes. The level detection is done through a float switch connected at the input FS (closed under normal condition, and opened when water overflows). System operation is according to the following chart:

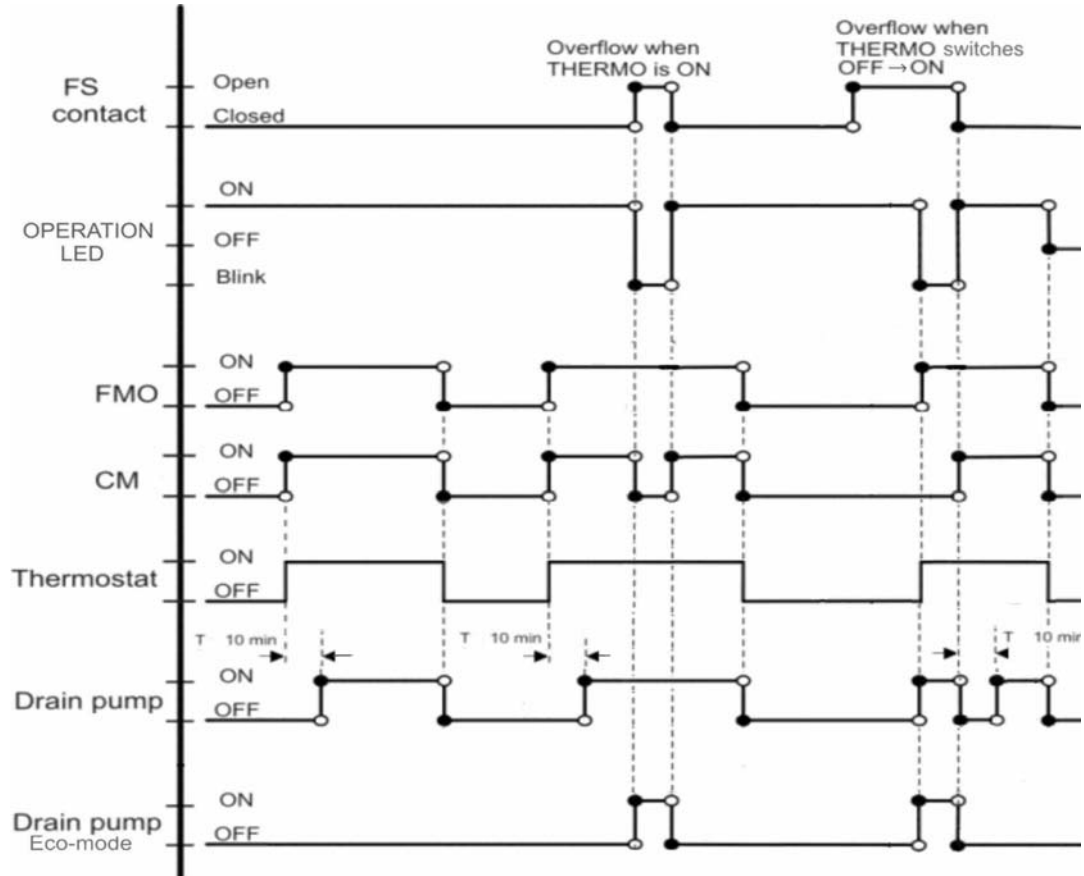

## 21 Safety thermostat

The unit is equipped with a double safety system to prevent overtemperature of the electrical heater. The control of temperature is done through the automatic thermostat (AT) and safety thermostat (ST).

The safety thermostat (ST), if activated, can be reset only manually by pushing the button, placed on the right side of the air inlet, behind the air filter.

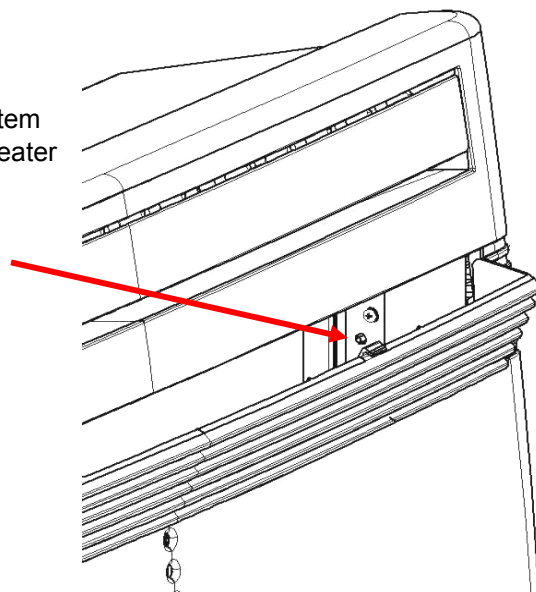

ARGO HPL/SCL

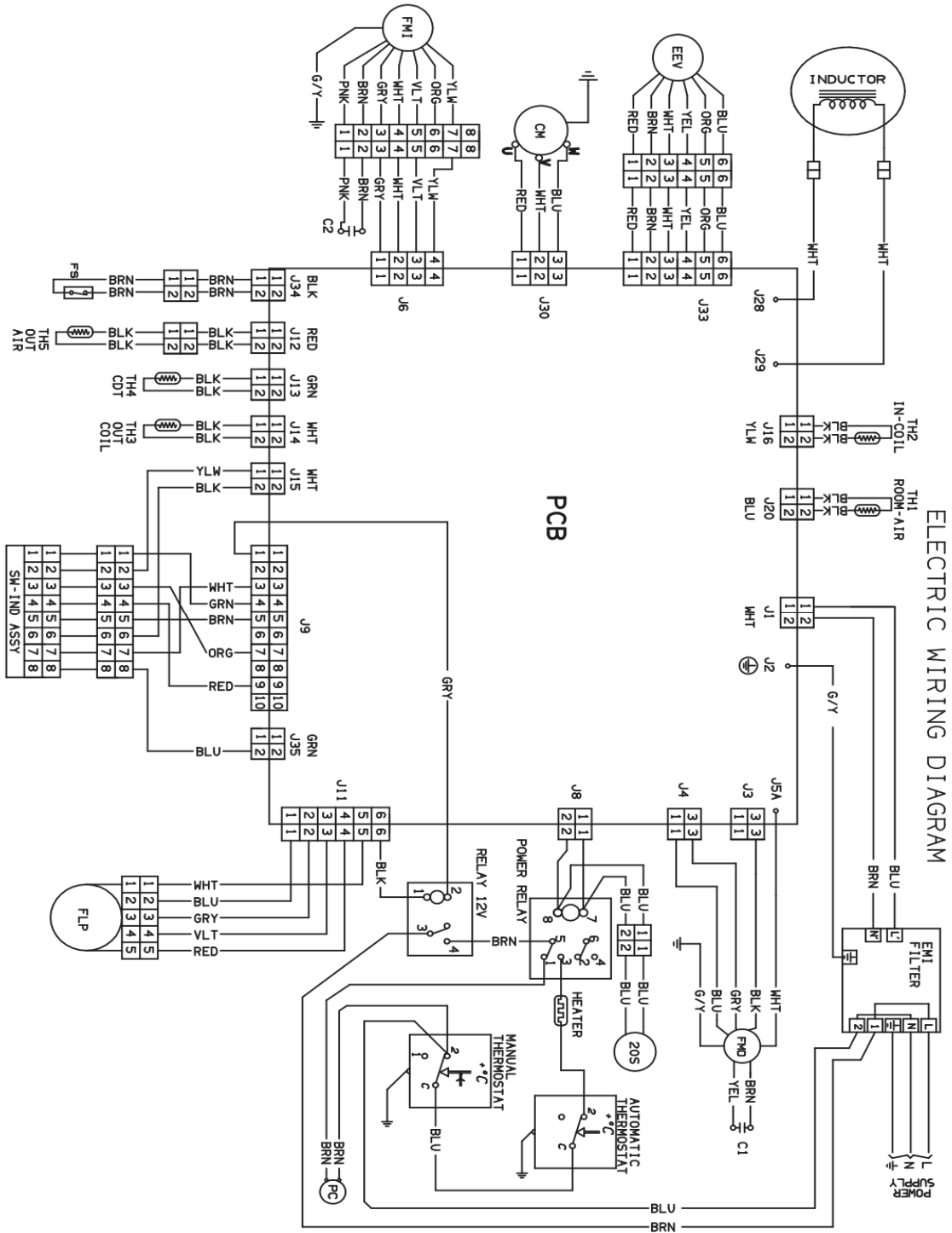

LEGENDA

<b>PCB</b>	Controller	<b>SW-IND-ASSY</b>	Indicator assy
<b>FMI</b>	Indoor fan motor	<b>TH1-2-3-4-5</b>	Thermistor
<b>CM</b>	Compressor motor	<b>ST</b>	safety thermostat
<b>FMO</b>	Outdoor fan motor	<b>AT</b>	automatic thermostat
<b>RE</b>	Electric heater	<b>EF</b>	Emi filter
<b>C1-2</b>	Capacitor	<b>FS</b>	Float switch
<b>PC</b>	Condensate pump motor	<b>FLP</b>	Flap motor
<b>20S</b>	4-way valve	<b>PR</b>	power relay
<b>EEV</b>	Expansion valve	<b>RP</b>	pump relay

## 1 CHECK BEFORE AND AFTER «TROUBLESHOOTING»

### (A) Check power supply wiring.

- Check the power supply wires are correctly connected.

### (B) Check power supply.

- Check that voltage is in specified range ( $\pm 10\%$  of the rating).
- Check that power is being supplied.

• **WARNING:** If the following troubleshooting must be done with power supplied, be careful not to touch any uninsulated live part that can cause *electric shock*

## 2 CIRCUIT BREAKER TRIPS OR FUSE BLOWS.

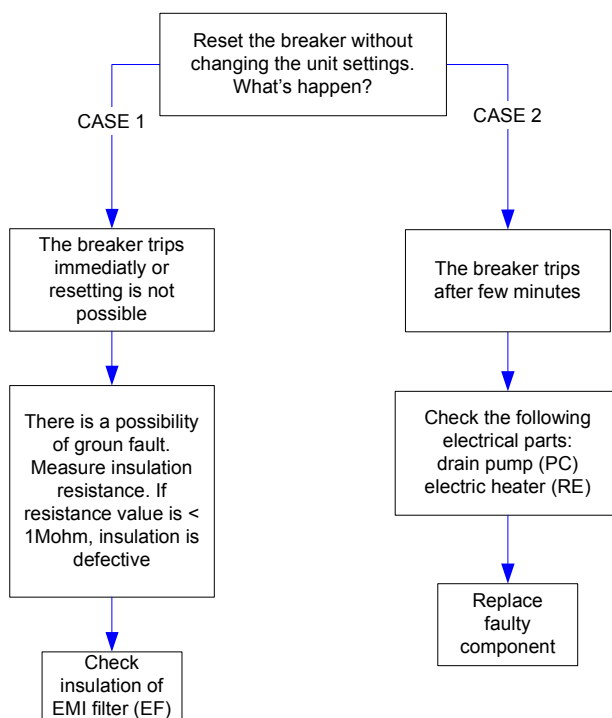

**3 UNIT DOES NOT RUN.**

**3.1 - THERE IS NO SIGNALING LED ON UNIT**

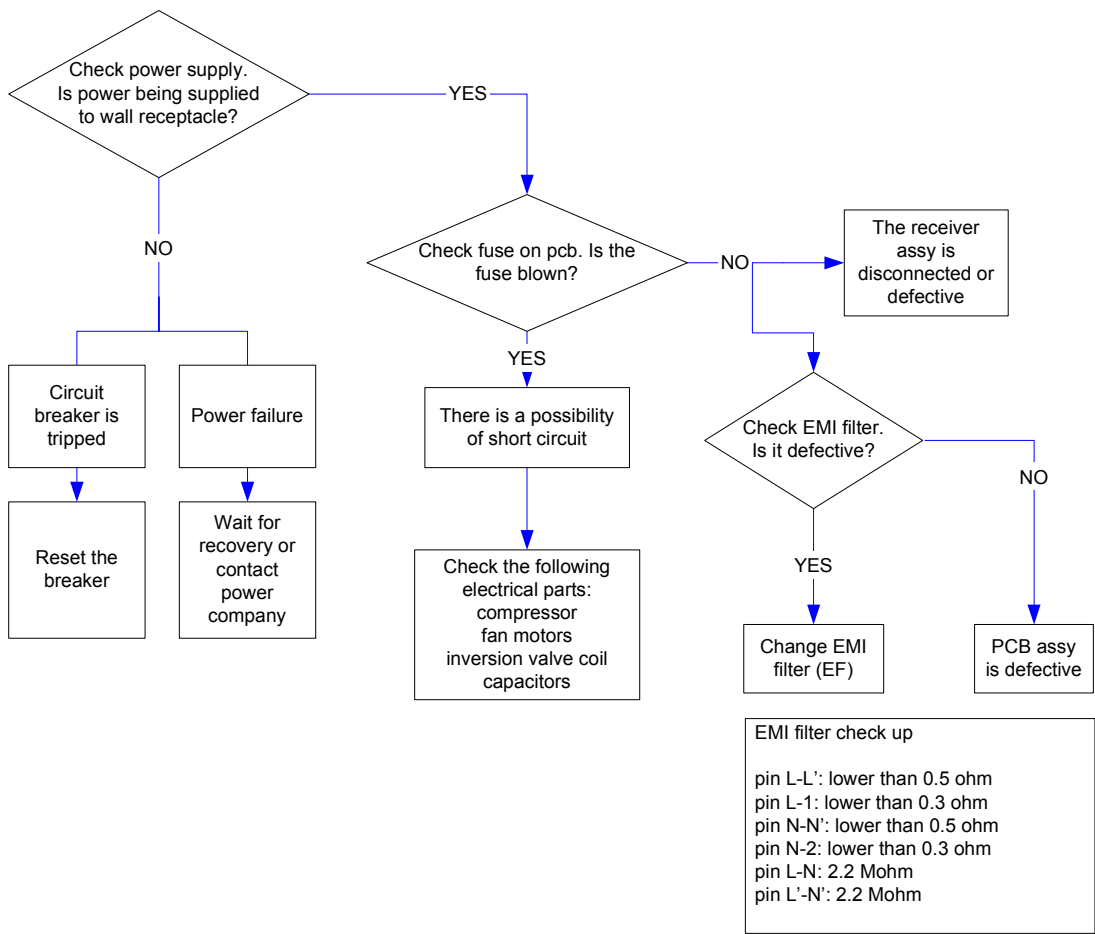

### 3 UNIT DOES NOT RUN.

#### 3.2 -THERE IS ONE LED ON AT LEAST AND THE UNIT DOES NOT RECEIVES THE REMOTE CONTROL SIGNAL

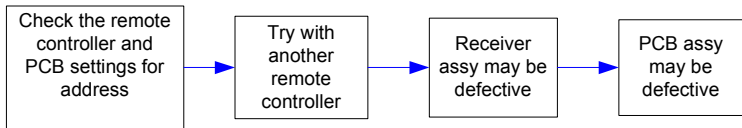

#### 3.3 -THERE IS ONE LED ON AT LEAST AND THE UNIT RECEIVES THE REMOTE CONTROL SIGNAL

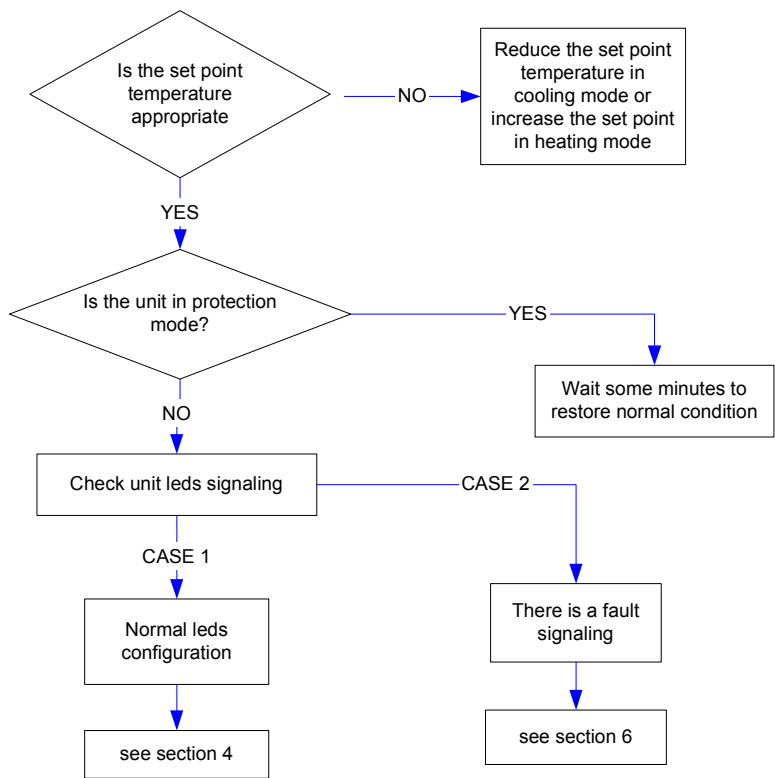

3 UNIT DOES NOT RUN.

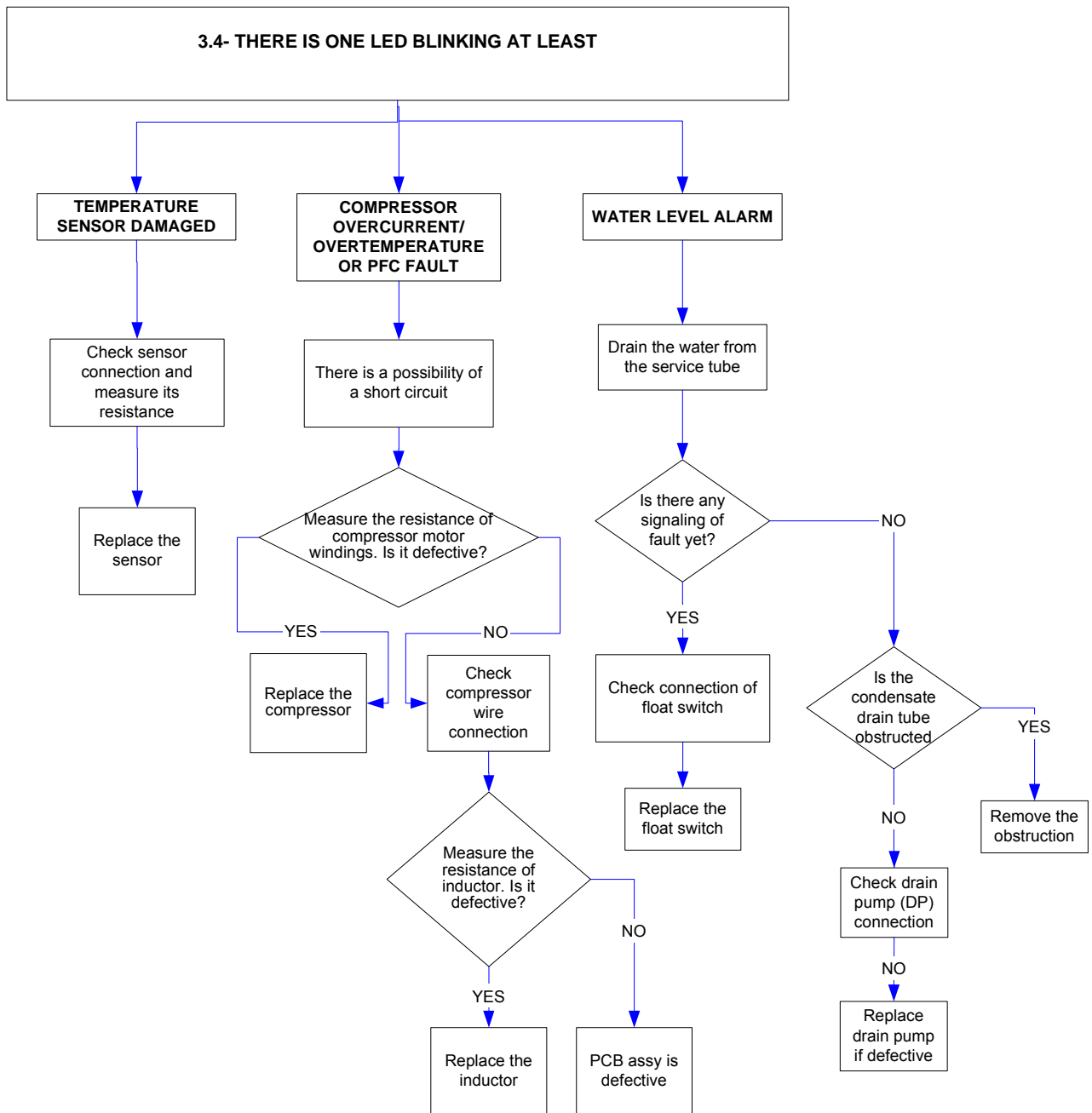



#### 4 UNIT DOES NOT RUN OR RUN FOR FEW MINUTES AND NO FAULT IS DISPLAYED

Before checking the unit with this test, follow these 4 steps

- 1) Turn off power supply
- 2) Wait 1 minute until the receiver leds switch off
- 3) Turn on power supply
- 4) Wait until the system starts (about 3 minutes)

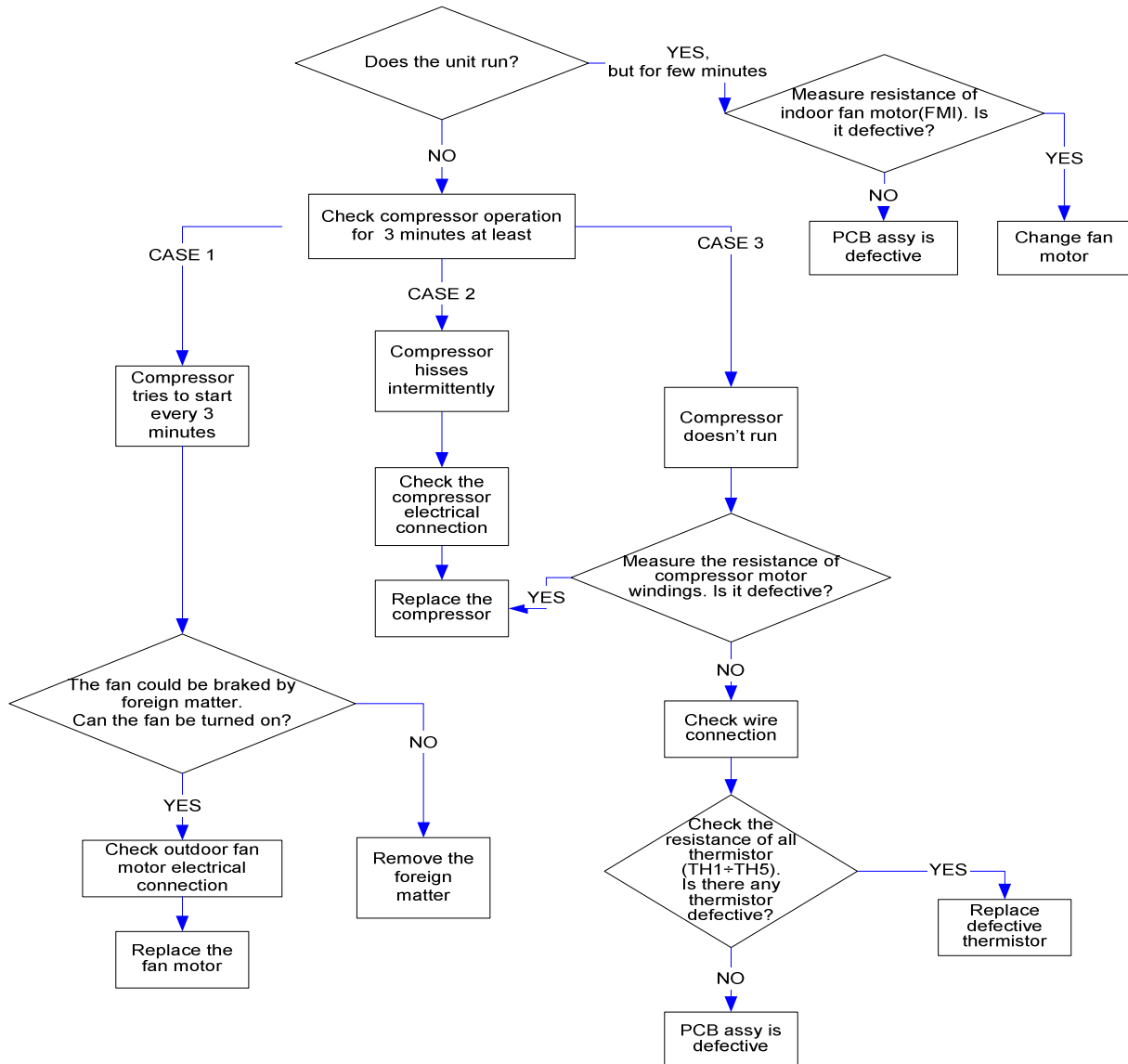

**5 AIR CONDITIONER OPERATES, BUT ABNORMALITIES ARE OBSERVED.**

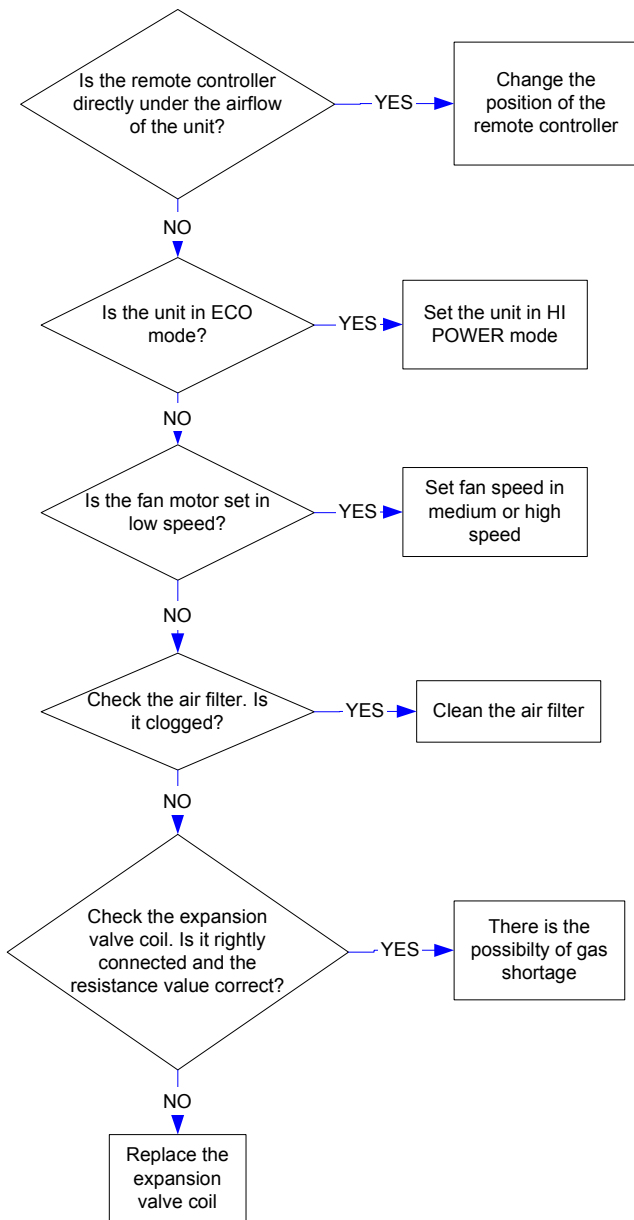

## 6 ELECTRICAL HEATER DOES NOT WORK

Before checking the unit with this test, follow these 3 steps

- 1) Switch the unit in FAN HEATER mode and fan on LOW speed for 3 minutes
- 2) Measure the power or current consumption directly from the power supply line

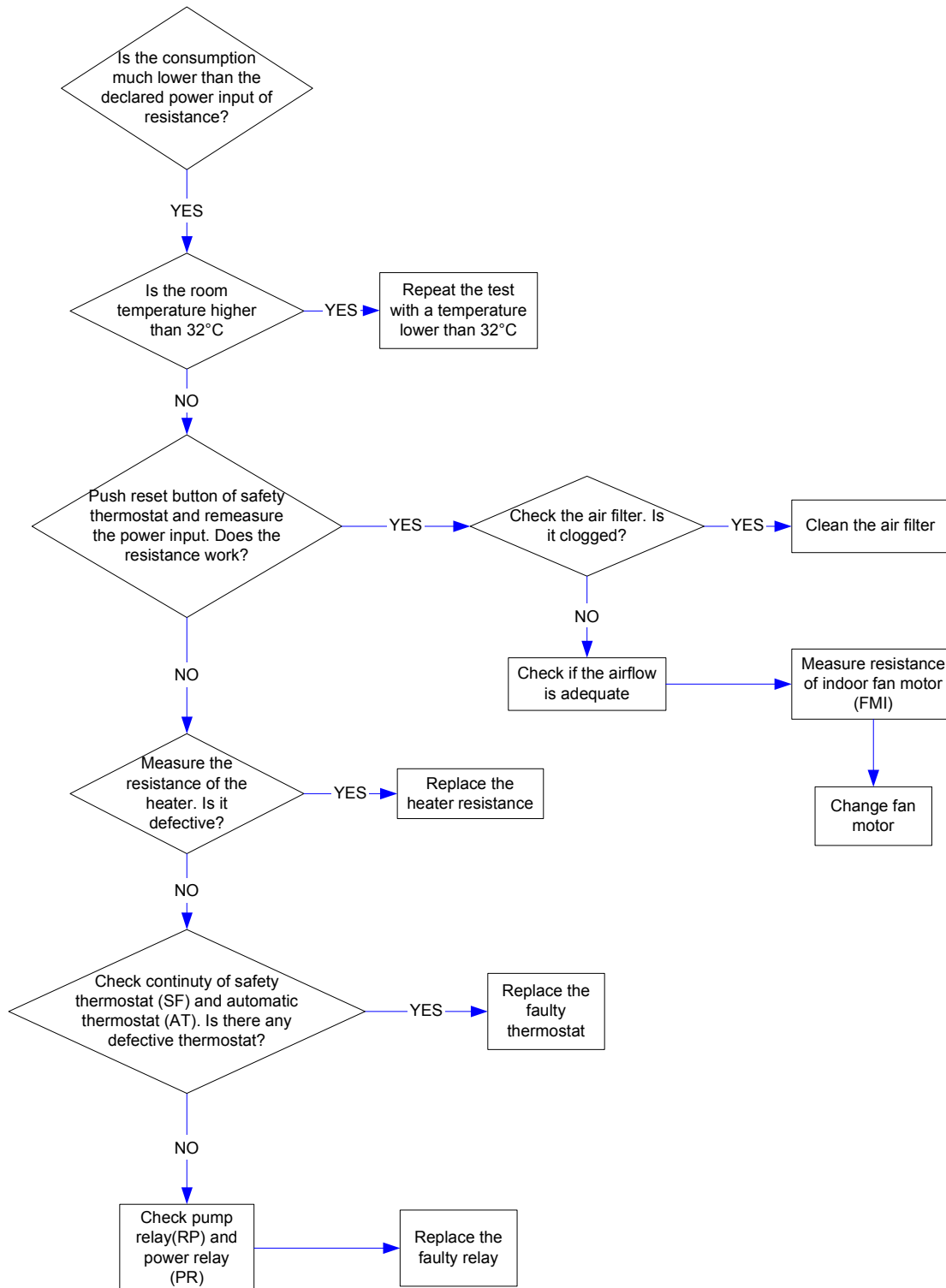

## 7 AIR CONDITIONER OPERATES, BUT ABNORMALITIES ARE OBSERVED.

### 1 - OPERATION DOES NOT SWITCH FROM HEAT TO COOL AND FROM COOL TO HEAT

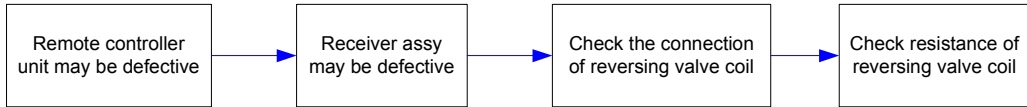

### 2 - CHECK "MODE BUTTON" OPERATION ON THE UNIT

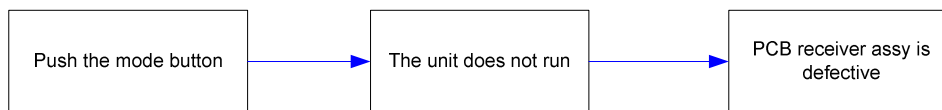

### 3 - CHECK REMOTE CONTROLLER UNIT

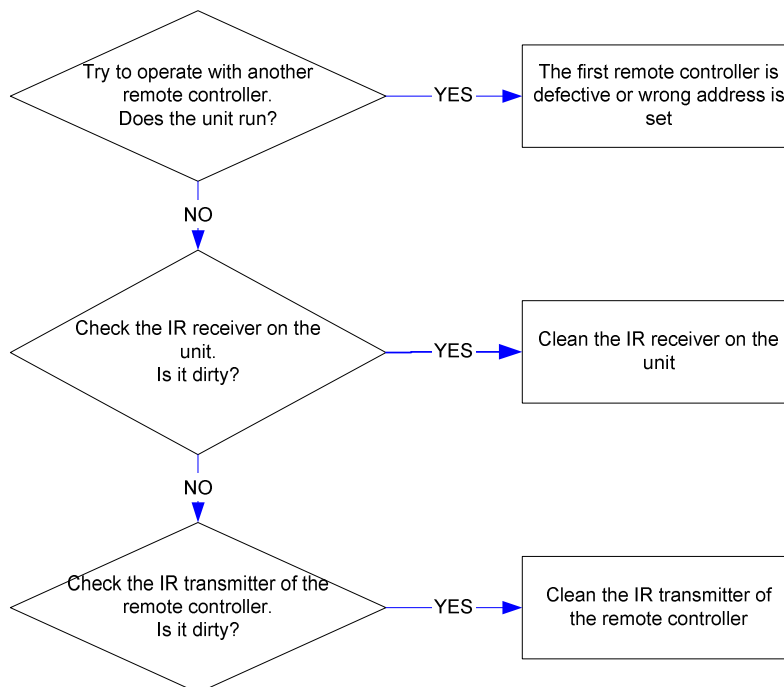

## 8 UNUSUAL NOISE IS OBSERVED

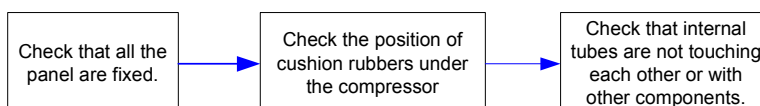

### 1 Measurement of Insulation Resistance

The insulation is in good condition if the resistance exceeds 1 Mohm

**a) Power Supply Wires**

Clamp the earthed wire of the power supply wires with the lead clip of the insulation resistance tester and measure the resistance by placing a probe on either of the power wires (fig.1).  
Then measure the resistance between the earthed wire and the other power wires (fig.1).

**b) Unit**

Clamp an alluminium plate fin or copper tube with the lead clip of the insulation resistance tester and measure the resistance by placing a probe on N terminal, and then on Lterminal the terminal plate (fig.2)

**c) Measurement of Insulation Resistance for Electrical Parts**

Disconnect the lead wires of the disired electric part from terminal plate, PCB assy, capacitor, etc.  
Similary disconnect the connector. Then measure the insulation resistance (fig.1 to 4).  
Refer to electric wiring diagram.

**NOTE**

If the probe cannot enter the poles because the hole is too narrow then use a probe with a thinner pin.

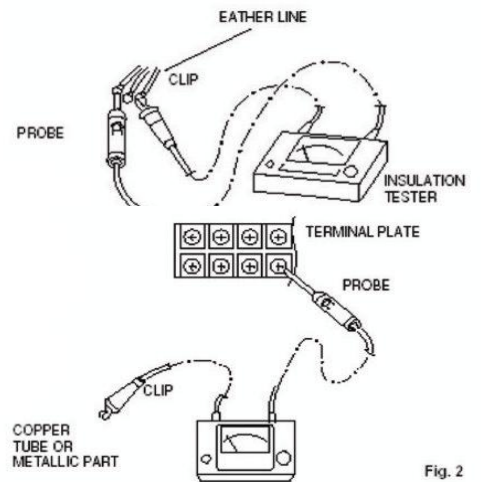

Fig. 2

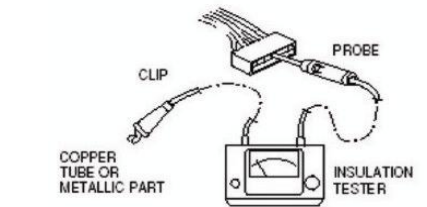

Fig. 3

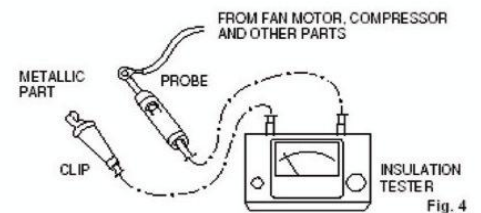

Fig. 4

### 2 Checking Continuity of fuse on PCB assy

Remove PCB assy from electrical component box (fig.5)  
Then pull out the fuse from PCB assy

Check continuity of fuse by the multimeter (fig.6)

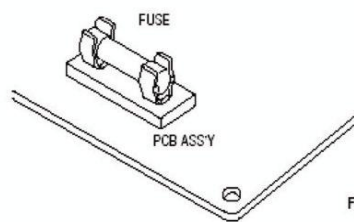

Fig. 5

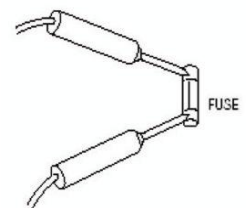

Fig. 6

### 3 Checking Motor Capacitor

Remove the lead wires from the capacitor terminals, and then place a probe on the capacitor terminals as shown in fig.7.  
Observe the deflection of the pointer, setting the resistance measuring range of the multimeter to the maximum value.  
The capacitor is "good" if the pointer bounces to a great extent and the gradually returns to its original position.  
The range of deflection and deflection time deffer according to capacity of the capacitor.

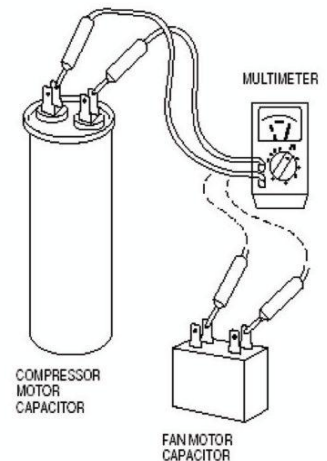

Fig. 7

**argoclima** s.p.a.

Via Varese, 90 - 21013 Gallarate - Va - Italy  
Tel. +39 0331 755111 - Fax +39 0331 776240  
[www.argoclima.it](http://www.argoclima.it)