

# Service Manual

Room Air Conditioners

**CS-MVG103KE**  
**CU-MVG153KE**

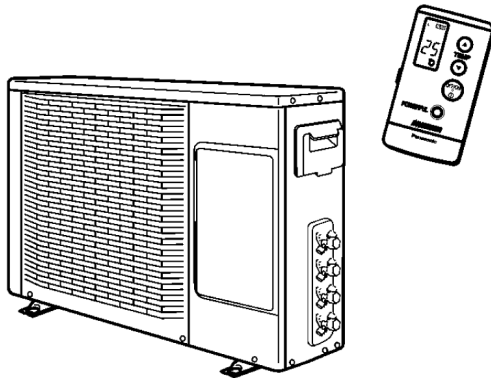
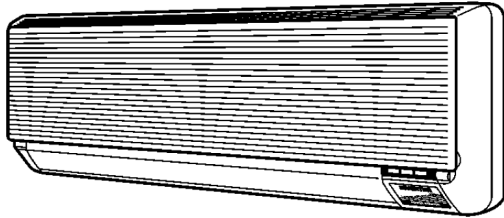

## **⚠ WARNING**

This service information is designed for experienced repair technicians only and is not designed for use by the general public. It does not contain warnings or cautions to advise non-technical individuals of potential dangers in attempting to service a product. Products powered by electricity should be serviced or repaired only by experienced professional technicians. Any attempt to service or repair the product or products dealt with in this service information by anyone else could result in serious injury or death.

## **IMPORTANT SAFETY NOTICE**

There are special components used in this equipment which are important for safety. These parts are marked by **⚠** in the Schematic Diagrams, Circuit Board Diagrams, Exploded Views and Replacement Parts List. It is essential that these critical parts should be replaced with manufacturer's specified parts to prevent shock, fire or other hazards. Do not modify the original design without permission of manufacturer.

# Panasonic

© 1999 Matsushita Electric Industrial Co., Ltd. All rights reserved. Unauthorized copying and distribution is a violation of law.

# CONTENTS

	Page		Page
<b>1 Features</b> .....	<b>2</b>	9.2. PROTECTION CONTROL FOR COOLING & SOFT DRY .....	39
<b>2 Functions</b> .....	<b>3</b>	9.3. PROTECTION CONTROL FOR HEATING OPERATION .....	40
2.1. REMOTE CONTROL .....	3	<b>10 Installation And Servicing Air Conditioner Using R410A</b> .....	<b>41</b>
2.2. INDOOR UNIT .....	4	10.1. OUTLINE .....	41
2.3. OUTDOOR UNIT .....	6	10.2. TOOLS FOR INSTALLING/SERVICING REFRIGERANT PIPING .....	42
<b>3 Product Specifications</b> .....	<b>7</b>	10.3. REFRIGERANT PIPING WORK .....	46
<b>4 Dimensions</b> .....	<b>9</b>	10.4. INSTALLATION, TRANSFERRING, SERVICING .....	48
4.1. CS-MVG103KE (INDOOR UNIT) .....	9	<b>11 Installation Information</b> .....	<b>52</b>
4.2. CU-MVG153KE (OUTDOOR UNIT) .....	10	11.1. ATTACHED ACCESSORIES .....	52
<b>5 Refrigeration Cycle Diagram</b> .....	<b>11</b>	11.2. SELECT THE BEST LOCATION .....	52
<b>6 Block Diagram</b> .....	<b>12</b>	11.3. INDOOR/OUTDOOR UNIT INSTALLATION DIAGRAM .....	54
<b>7 Wiring Diagram</b> .....	<b>13</b>	11.4. CONNECTION PIPES FOR AIR CONDITIONER UNITS WITH R410A .....	55
7.1. CS-MVG103KE (INDOOR UNIT) .....	13	11.5. NOTE .....	55
7.2. CU-MVG153KE (OUTDOOR UNIT) .....	14	<b>12 Servicing Information</b> .....	<b>56</b>
<b>8 Operation Details (FUNCTIONS)</b> .....	<b>15</b>	12.1. TROUBLESHOOTING .....	56
8.1. SIMULTANEOUS OPERATION CONTROL .....	15	12.2. SELF DIAGNOSIS DISPLAY .....	58
8.2. TEMPERATURE SHIFT .....	16	12.3. REMOTE CONTROL .....	60
8.3. COMPRESSOR OPERATING FREQUENCY OPERATION .....	17	12.4. DISASSEMBLY OF PARTS .....	61
8.4. COOLING OPERATION .....	18	<b>13 Technical Data</b> .....	<b>69</b>
8.5. SOFT DRY OPERATION .....	20	13.1. OPERATION CHARACTERISTICS .....	69
8.6. HEATING OPERATION .....	21	<b>14 Electronic Circuit Diagram</b> .....	<b>71</b>
8.7. FAN OPERATION .....	25	14.1. HOW TO USE ELECTRONIC CIRCUIT DIAGRAM .....	71
8.8. AUTOMATIC OPERATION .....	25	14.2. TIMER TABLE .....	71
8.9. INDOOR FAN SPEED CONTROL .....	27	14.3. INDOOR UNIT .....	72
8.10. OUTDOOR FAN CONTROL .....	29	14.4. OUTDOOR UNIT .....	74
8.11. AIRFLOW DIRECTION .....	29	14.5. REMOTE CONTROLLER .....	76
8.12. QUIET OPERATION .....	31	<b>15 Printed Circuit Board</b> .....	<b>77</b>
8.13. POWERFUL MODE OPERATION .....	31	15.1. INDOOR UNIT .....	77
8.14. SLEEP MODE OPERATION .....	32	15.2. OUTDOOR UNIT / MAIN PCB .....	79
8.15. DELAY ON TIMER CONTROL .....	33	15.3. OUTDOOR UNIT / TRANSISTOR MODULE .....	81
8.16. AUTO RESTART CONTROL .....	33	<b>16 Exploded View &amp; Replacement Parts List</b> .....	<b>82</b>
8.17. POWER MONITOR DISPLAY .....	34	16.1. CS-MVG103KE .....	82
8.18. REMOTE CONTROL SIGNAL RECEIVING SOUND ON/OFF .....	34	16.2. CU-MVG153KE .....	84
<b>9 Operation Details (PROTECTION)</b> .....	<b>35</b>	<b>17 Electronic Parts List</b> .....	<b>86</b>
9.1. PROTECTION CONTROL FOR ALL OPERATIONS .....	35		

## 1 Features

### • Product

- Powerful Mode for quick cool/heat
- Compressor operating frequency control to maintain desired room temperature
- Automatic Restart after power failure
- Washable front panel
- Power Monitor Display

### • Serviceability

- Self diagnosis
- Test Run at both Cooling and Heating rated frequency

### • Quality Improvement

- High power supply voltage protection
- Low power supply voltage protection
- Gas leakage detection

## 2 Functions

### 2.1. REMOTE CONTROL

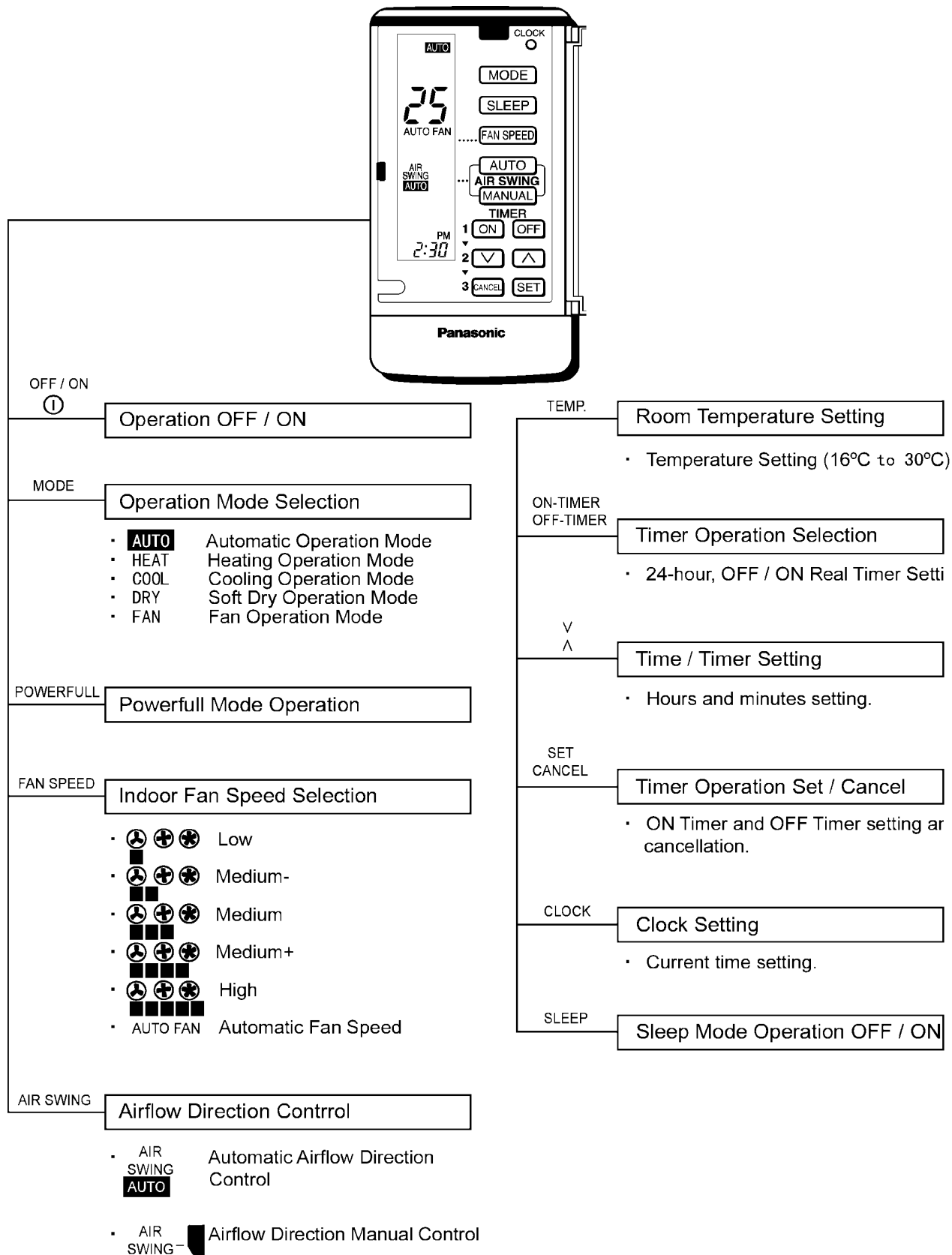

## 2.2. INDOOR UNIT

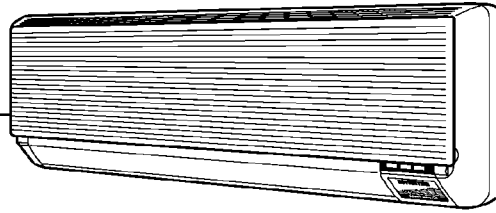

### FOR ALL OPERATIONS

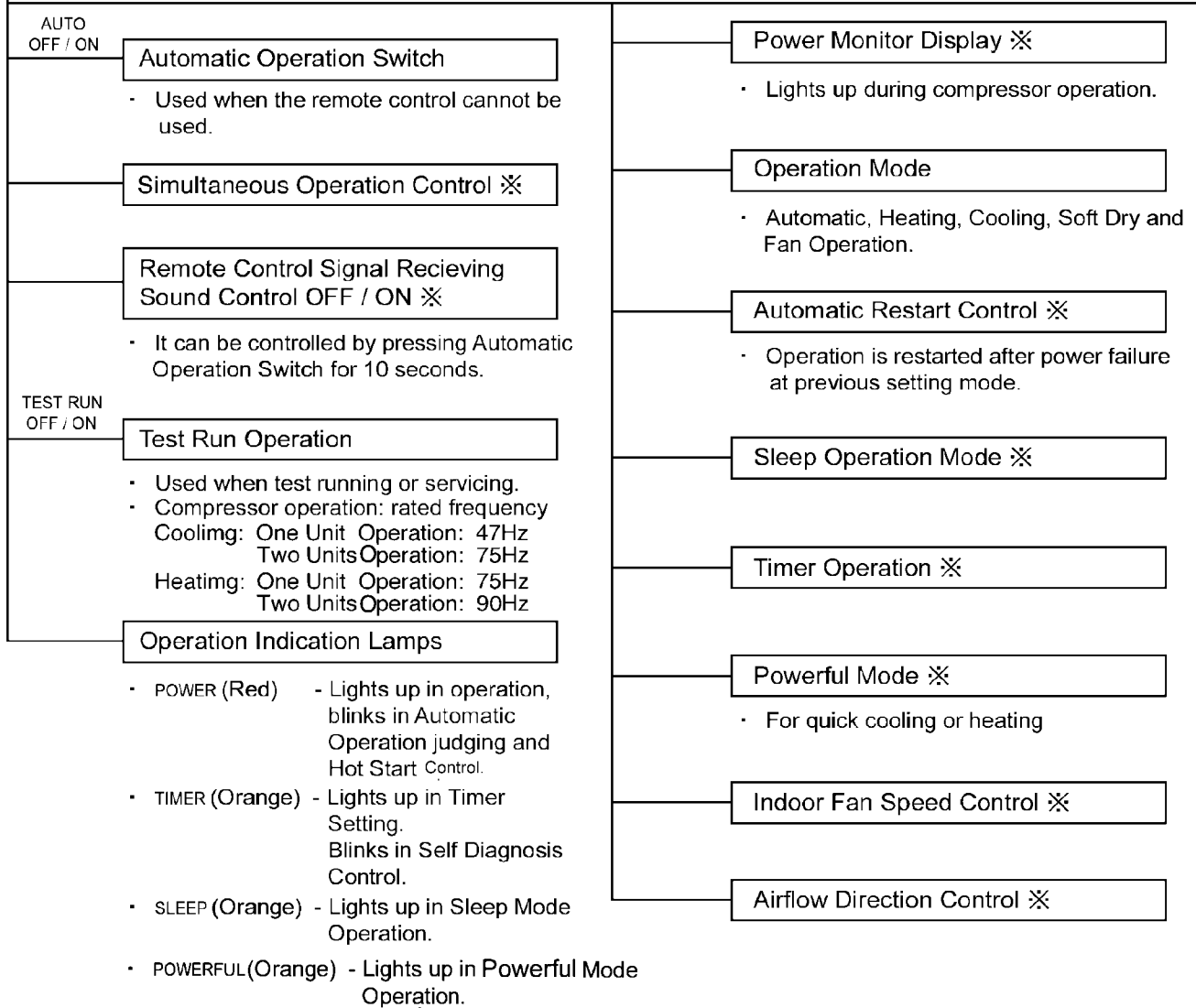

COOLING/SOFT DRY OPERATION

Room Temperature Control ※		
Operation Mode	Compressor Operation Frequency	
	One Indoor Unit Operation	Two Indoor Units Operation
	Cooling	15 ~ 67 Hz    15 ~ 77 Hz
	Soft Dry	15 ~ 39 Hz    15 ~ 41 Hz
Heating	15 ~118 Hz    15 ~125 Hz	

Temperature Shift ※

Self Diagnosis ※

Low Pressure Control ※  
(Gas Leakage Detection)

High Power Supply Voltage Protection ※

Indoor Power Relay Control ※

Deodorizing Control ※

Sensible Heat Control ※

Anti-Fog Discharge Control ※

Anti-Dew Formation Control ※

Anti-Freezing Control ※

Quiet Operation ※

HEATING OPERATION

Anti-Cold Draft Control ※

Hot Start ※

Intake Air Temperature Control ※

High Pressure Control ※

AUTOMATIC OPERATION

FAN OPERATION

## 2.3. OUTDOOR UNIT

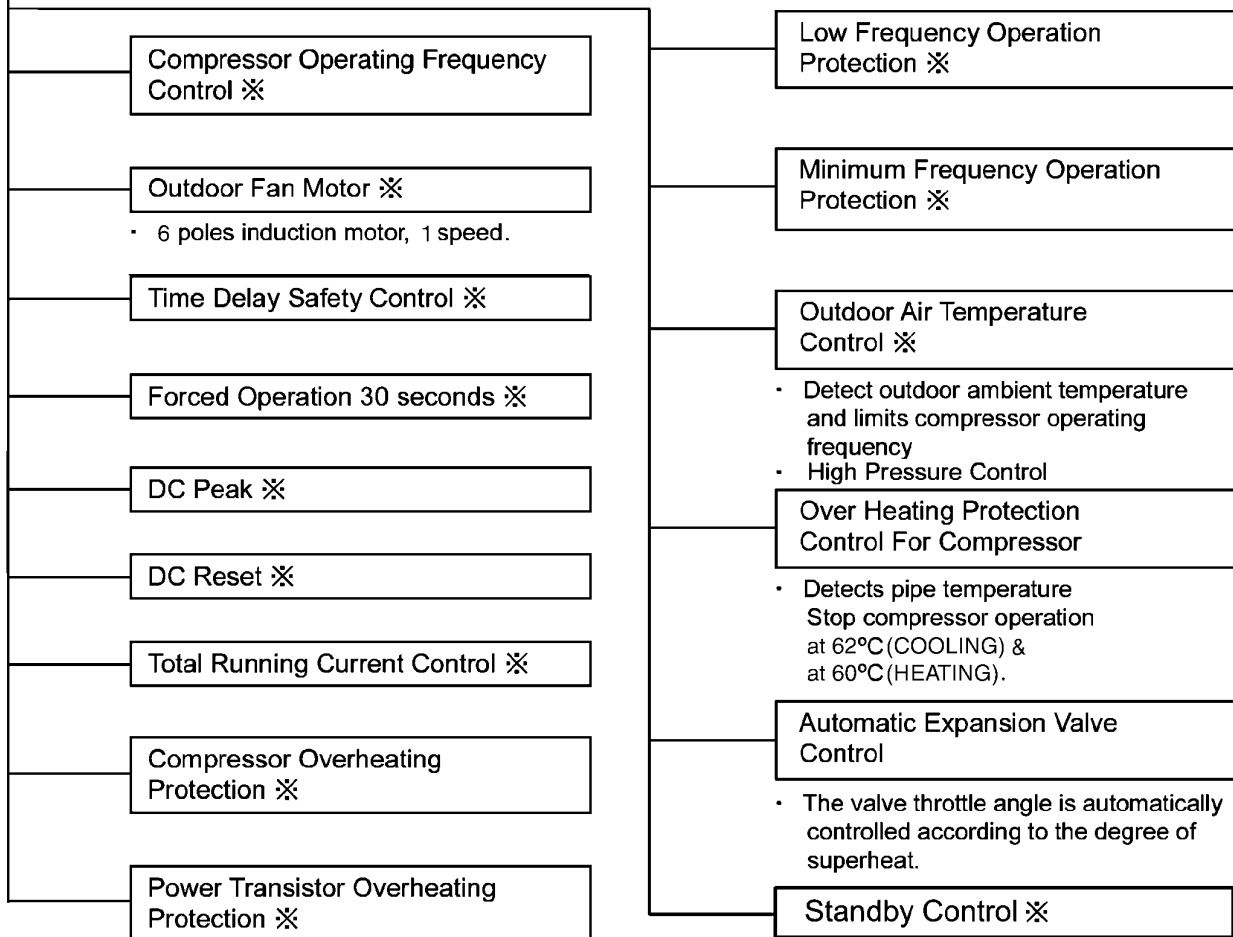
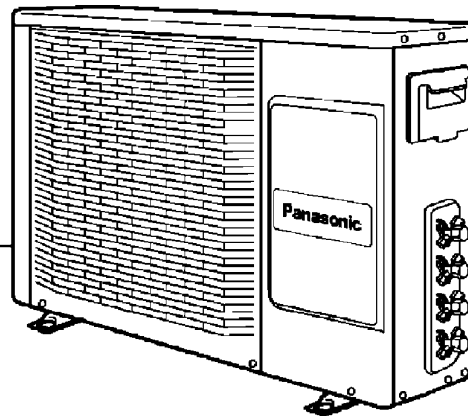

※ Details can be referred to OPERATION DETAIL in this manual.

### 3 Product Specifications

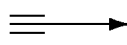
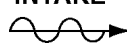
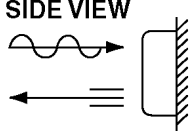
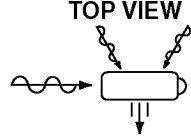
		Unit	CS-MVG103KE	CU-MVG153KE	
Cooling Capacity			(1 unit) 2.8(0.7 ~ 3.5) 9,500(2,400 ~ 11,900)	(2 units) 2.25(0.45 ~ 2.3) x 2 7,650(1,500 ~ 7,850) x 2	
Heating Capacity			(1 unit) 4.0(0.7 ~ 4.3) 13,600(2,400 ~ 14,700)	(2 units) 2.6(0.45 ~ 3.05) x 2 8,850(1,500 ~ 10,400) x 2	
Moisture Removal			(1 unit) 1.6 3.4	(2 units) 2.5 5.3	
Power Source		Phase V Cycle		Single 230 50	
Airflow Method		<b>OUTLET</b>  <b>INTAKE</b> 	<b>SIDE VIEW</b> 	<b>TOP VIEW</b> 	
Air Volume	Indoor Air(Lo)	m <sup>3</sup> / min(cfm)	Cooling ; 7.0(247) Heating ; 7.2(254)	-	
	Indoor Air(Me)	m <sup>3</sup> / min(cfm)	Cooling ; 7.6(268) Heating ; 7.8(275)	-	
	Indoor Air(Hi)	m <sup>3</sup> / min(cfm)	Cooling ; 8.3(293) Heating ; 8.5(300)	-	
	Outdoor Air	m <sup>3</sup> / min(cfm)	-	Hi; 30.0(1050)	
Noise Level		dB(A)	Cooling ; High 39,Low 27 heating ; High 39,Low 27	Cooling ; 46 Heating ; 47	
Electrical Data	Input	kW	(1 unit) Cooling ; 770(250 ~ 1,100) Heating ; 1,320(215 ~ 1,900)	(2 units) 1,350(255 ~ 1,380) 1,280(220 ~ 1,800)	
	Running Current	A	(1 unit) Cooling ; 3.70 ( max 5.40 ) Heating ; 6.35 ( max 9.90 )	(2 units) 6.50 ( max 6.70 ) 6.15 ( max 9.90 )	
	COP		(1 unit) Cooling ; 3.64 Heating ; 3.03	(2 units) 3.33 4.06	
	Starting Current	A		6.50	
Piping Connection Port (Flare piping)		inch inch	G ; Half Union 3/8" L ; Half Union 1/4"	G ; 3-Way valve 3/8" L ; 2-Way valve 1/4"	
Pipe Size (Flare piping)		inch inch	G(gas side) ; 3/8" L(liquid side) ; 1/4"	G(gas side) ; 3/8" L(liquid side) ; 1/4"	
Drain Hose	Inner diameter Length	mm m	12 0.7	- -	
Power Cord length Number of core-wire			- -	- -	
Dimensions	Height	inch(mm)	10 - 31/32(279)	25 - 25/32(540)	
	Width	inch(mm)	31 - 15/32(799)	30 - 3/4(780)	
	Depth	inch(mm)	7 - 15/32(190)	11 - 13/32(289)	
Net Weight		lb(kg)	20(9.0)	95(43)	
Compressor	Type		-	Rotary (2 cylinder)	
	Motor Type		-	Brushless(4-poles)	
	Rated Output	W	-	1,200	
Air Circulation	Type		Cross-flow Fan	Propeller Fan	
	Material		AS+Glass Fiber 30 %	AES+Glass Fiber 12 %	
	Motor Type		Transiator(4-poles)	Induction(6-poles)	
	Input	W	-	110	
	rated Output	W	20	25	
	Fan Speed	Low Cool(Heat)	rpm	880(970)	-
		Medium Cool(Heat)	rpm	1,100(1,170)	-
High Cool(Heat)		rpm	1,290(1,310)	700	
Heat Exchange	description		Evaporator	Condenser	
	Tube material		Copper	Copper	
	Fine material		Aluminium	Aluminium	
	Fine type		Slit Fin	Corrugated Fin	
	Row/Stage		(Plate fin configuration,forced draft) 2/14	2/24	
	FPI		21	17	
	Size(W x H x L)	mm	600 x 252 x 25.4	673 x 504 x 18.2 615 x 504 x 18.2	

	Unit	CS-MVG103KE	CU-MVG153KE
Refrigerant Control Device		-	Expansion Valve
refrigeration Oil	(c.c)	-	RB88A(290)
Refrigerant(R410A)	g(oz)	-	1250(44.1)
Thermostat		Electronic Control	-
Protection Device			Electronic Control
Air Filter	Material style	P.P Honeycomb	-
Capacity Control			Expansion valve
Fan motor Capacitor	$\mu$ F,VAC	-	2.0 $\mu$ F,400VAC

· Specifications are subject to change without notice for further improvement.



# 4 Dimensions

## 4.1. CS-MVG103KE (INDOOR UNIT)

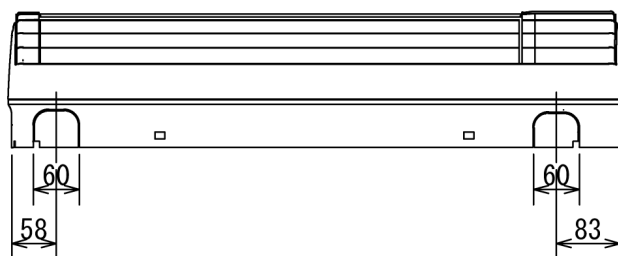
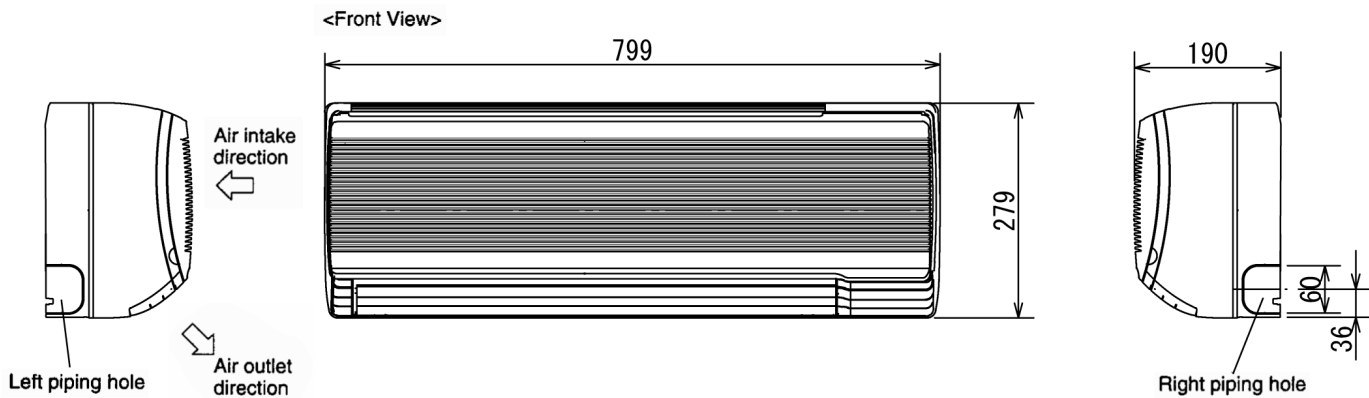

Remote control transmitter

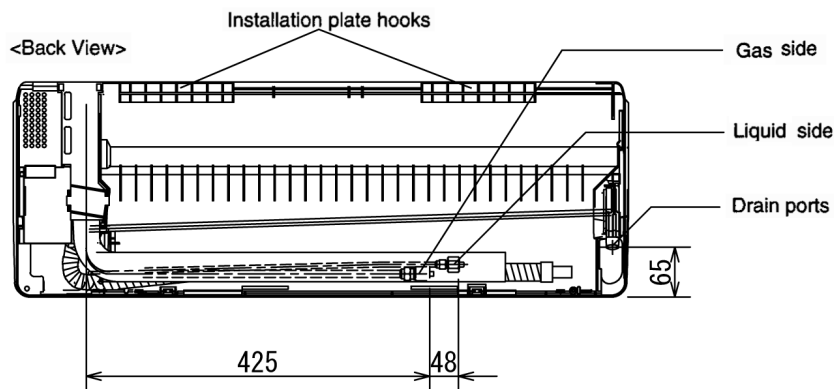
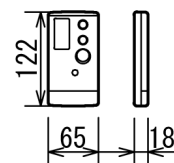

Relative position between the indoor unit and the installation plate <Front View>

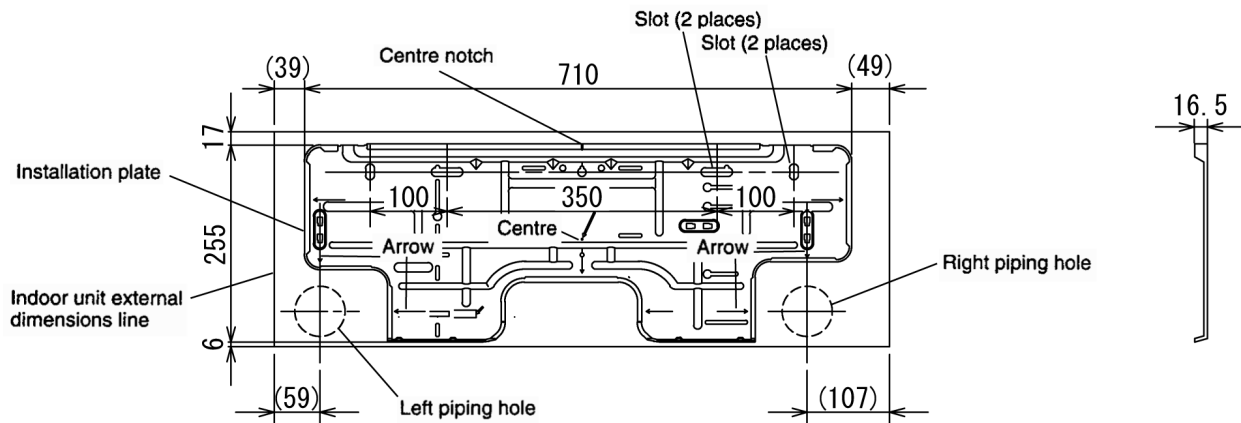

## 4.2. CU-MVG153KE (OUTDOOR UNIT)

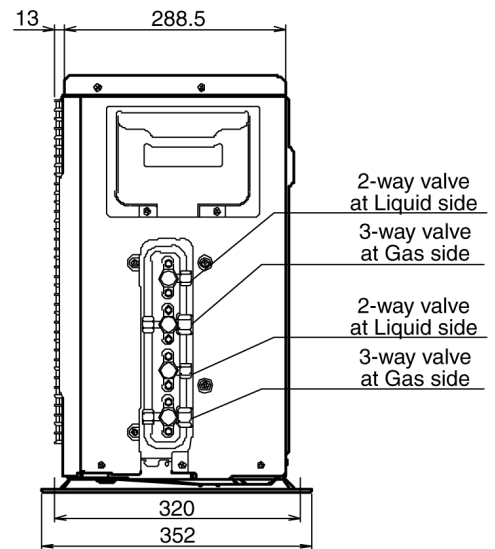
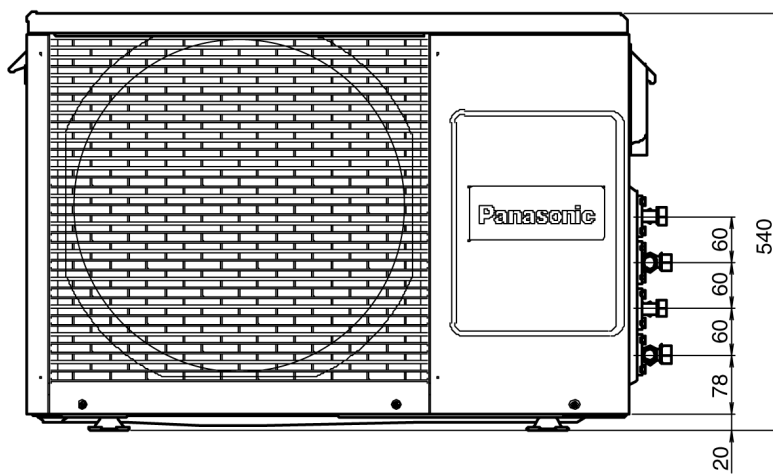
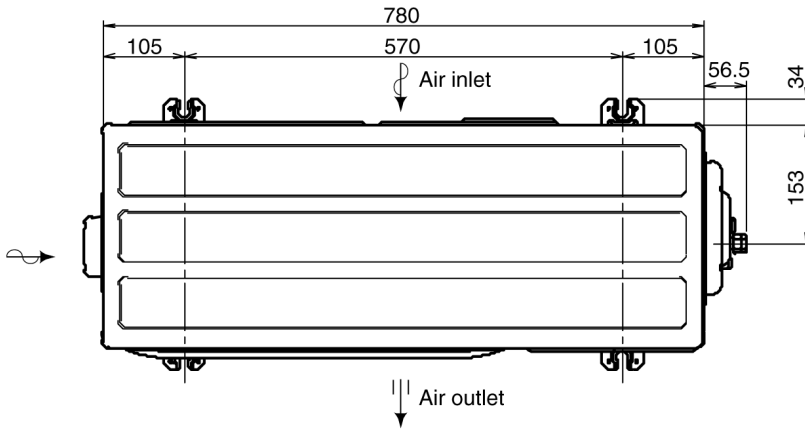

# 5 Refrigeration Cycle Diagram

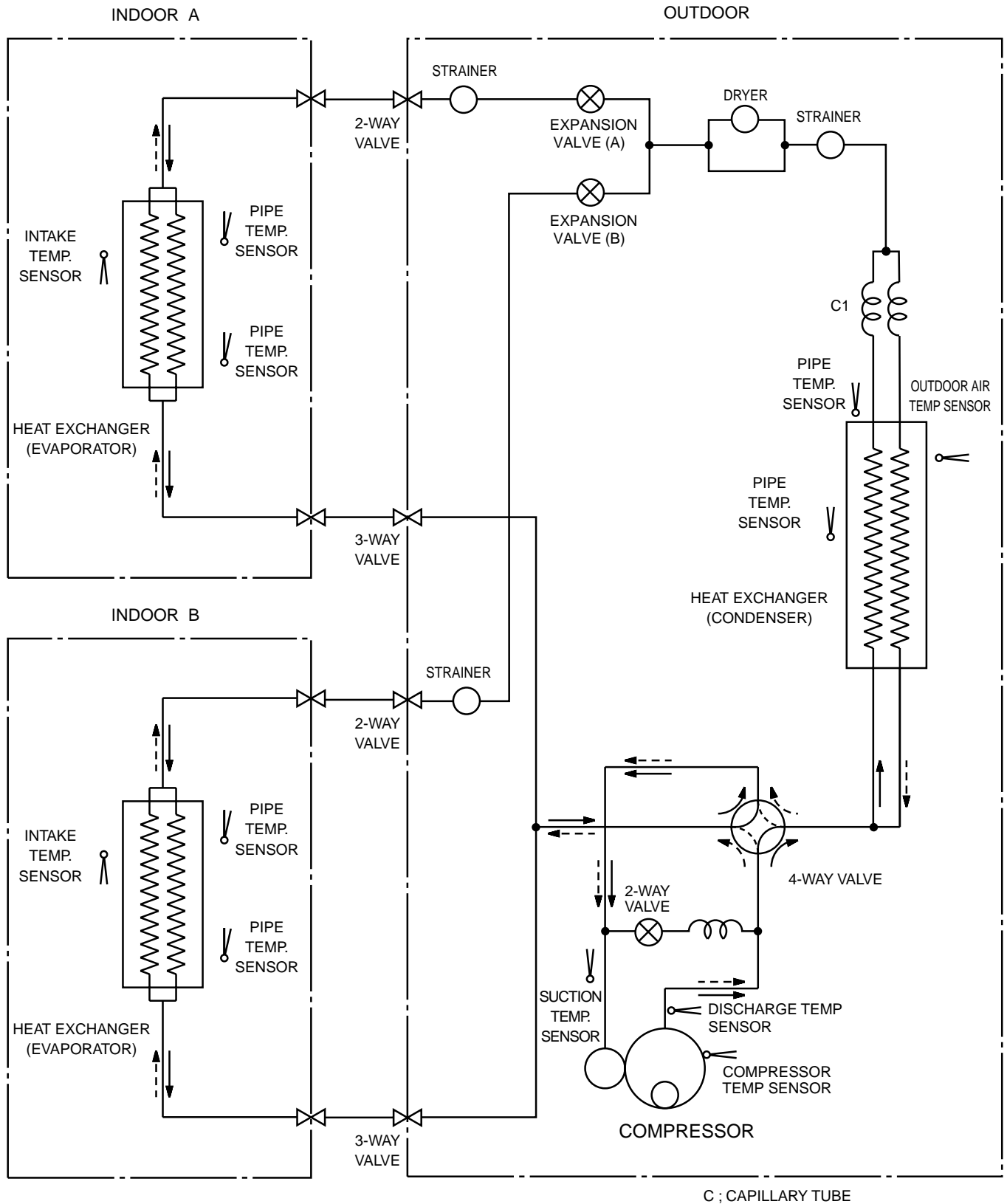

—→ COOLING  
 - - - → HEATING

# 6 Block Diagram

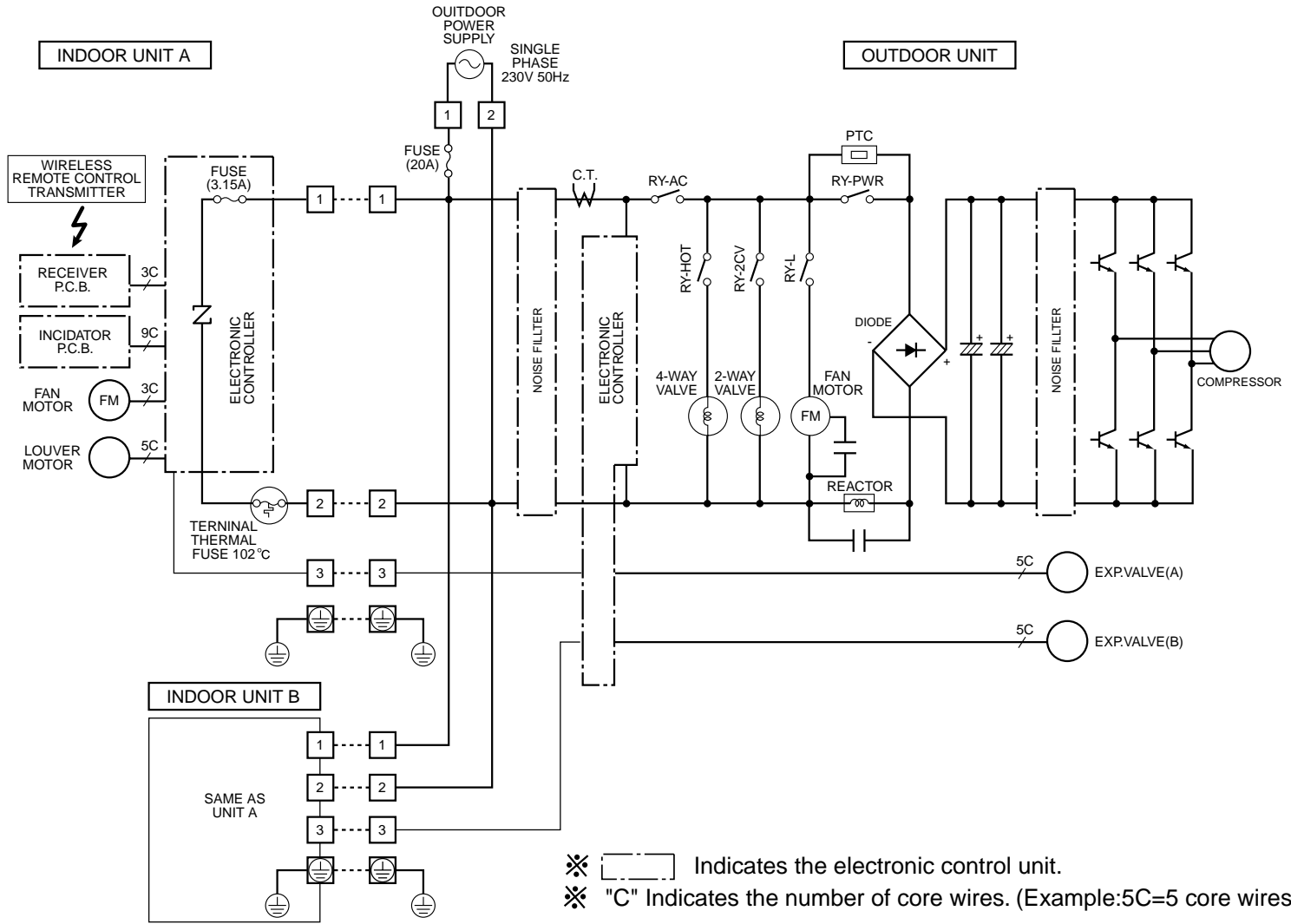

# 7 Wiring Diagram

## 7.1. CS-MVG103KE ( INDOOR UNIT )

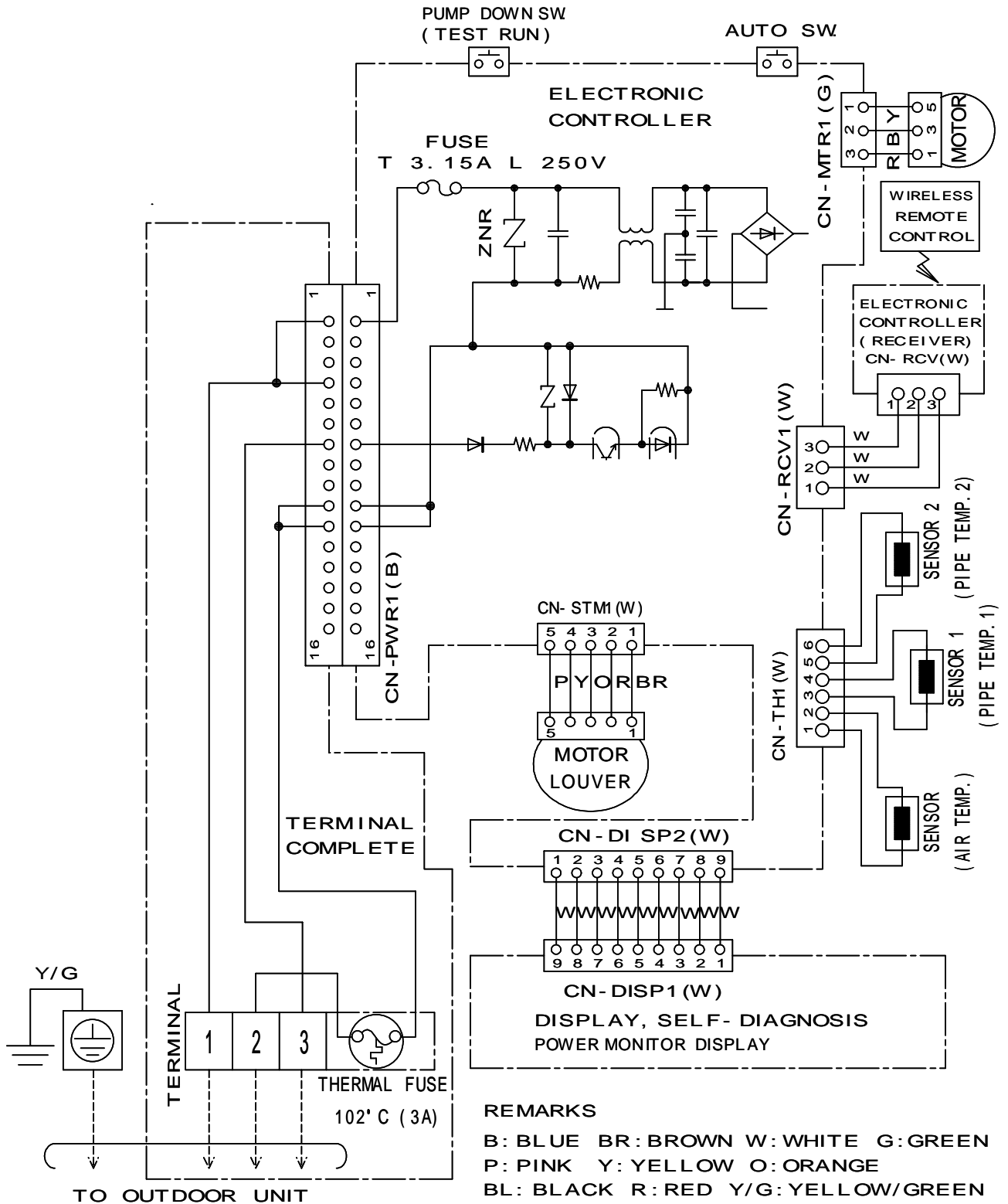

## 7.2. CU-MVG153KE ( OUTDOOR UNIT )

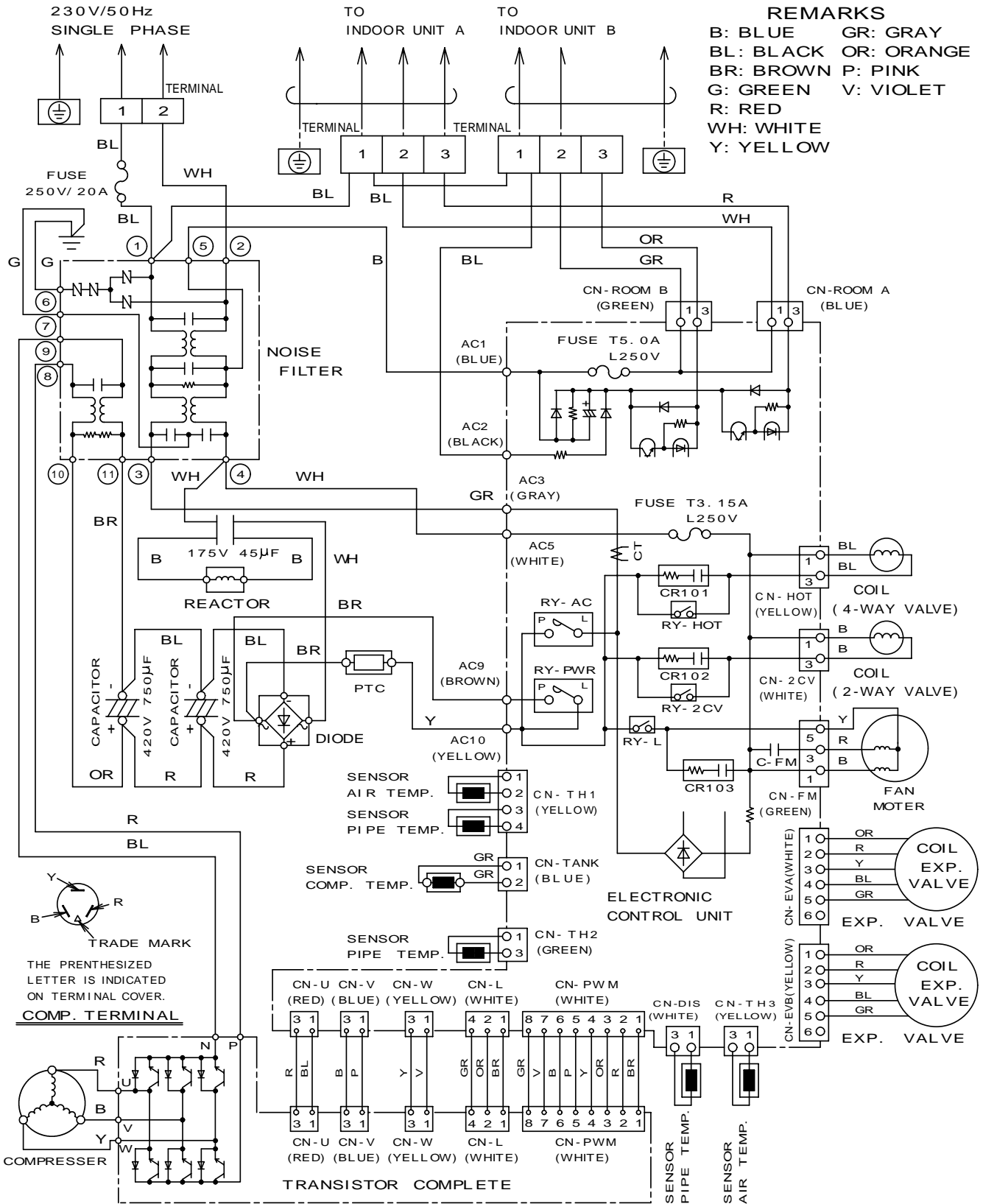

Resistance of Outdoor Fan Motor Windings

CONNECTION	CWA951029(Ω)
YELLOW - RED	257.2
YELLOW - BLUE	265.2

Resistance of Compressor Windings

CONNECTION	(Ω)
U-V	1.0
U-W	1.0
V-W	1.0

## 8 Operation Details (FUNCTIONS)

### 8.1. SIMULTANEOUS OPERATION CONTROL

- If the type of operation (such as heating or cooling) that one indoor unit is supposed to be performing, differs from the other, one of the indoor units might not function under certain circumstances.

#### Simultaneous operation permitted

- Select operation types that permit simultaneous operation from operation examples ① through ⑤ in the following table.

Operation example	Indoor unit that begins operating first	Indoor unit that begins operating subsequently
①	Heating	Heating
②	Cooling or Soft Dry	Cooling or Soft Dry
③	Cooling or Soft Dry	Fan
④	Fan	Cooling or Soft Dry
⑤	Fan	Fan

#### Simultaneous operation not permitted

- In the case of operation examples ⑥ through ⑨ in following table, one of the indoor units will not operate.

Operation example	Indoor unit that begins operating first	Indoor unit that is to begin operating subsequently	
⑥	Heating	Cooling or Soft Dry	The first unit that is already operating continues to do so.
⑦	Heating	Fan	
⑧	Cooling or Soft Dry	Heating	
⑨	Fan	Heating	The fan operation stops.

- The operation indicator lamp lights or blinks on the subsequent indoor unit in examples ⑥, ⑦, and ⑧, and on the unit that is in fan operation in example ⑨, but the units do not blow air. In addition, the power monitor LOW lamp blinks.

- If the controls are set to perform the operations shown in examples ⑥ through ⑧, either:

- Turn off the indoor unit that is already operating, or
- Turn off the subsequent indoor unit.

Then change the settings by pressing the button for an operation that is permitted during simultaneous operation, and restart the unit that is stopped.

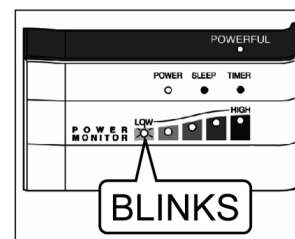

- If the controls are set to perform the operation shown in example ⑨:  
When the indoor unit that is performing the heating operation stops, the other unit resumes fan operation.

## 8.2. TEMPERATURE SHIFT

Once the operation starts, the remote control setting temperature will be shifted internally based on the setting fan speed and outdoor air temperature. In addition, if Sleep Mode or Powerful Mode are set, the temperature shift will be carried out.

Setting of internal Setting Temperature

The internal setting temperature can be decided as follows:

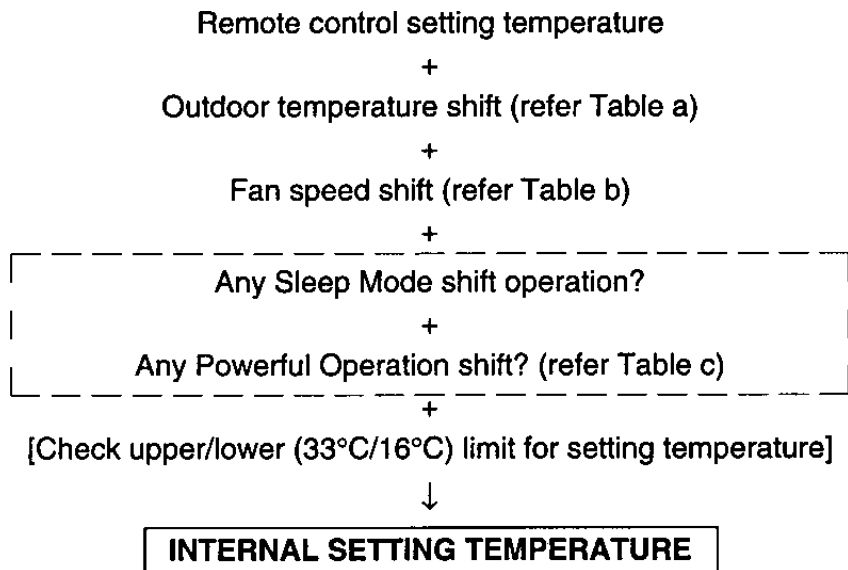

### 8.2.1. Table a

Setting Temperature Shift based on outdoor air temperature.

1. Cooling, Soft Dry

	Shift amount
$38^{\circ}\text{C} \leq \text{Outdoor air temperature}$	0.0°C
$30^{\circ}\text{C} \leq \text{Outdoor air temperature} < 38^{\circ}\text{C}$	0.0°C
$23^{\circ}\text{C} \leq \text{Outdoor air temperature} < 30^{\circ}\text{C}$	0.0°C
Outdoor air temperature < 23°C	+1.0°C

2. Heating

	Shift amount
$21^{\circ}\text{C} \leq \text{Outdoor air temperature}$	-2.0°C
$17^{\circ}\text{C} \leq \text{Outdoor air temperature} < 21^{\circ}\text{C}$	-1.5°C
$13^{\circ}\text{C} \leq \text{Outdoor air temperature} < 17^{\circ}\text{C}$	-1.5°C
$9^{\circ}\text{C} \leq \text{Outdoor air temperature} < 13^{\circ}\text{C}$	-1.0°C
$5^{\circ}\text{C} \leq \text{Outdoor air temperature} < 9^{\circ}\text{C}$	-0.5°C
$1^{\circ}\text{C} \leq \text{Outdoor air temperature} < 5^{\circ}\text{C}$	0.0°C
$-3^{\circ}\text{C} \leq \text{Outdoor air temperature} < 1^{\circ}\text{C}$	+1.0°C
Outdoor air temperature < -3°C	+1.5°C

### 8.2.2. Table b

Setting Temperature Shift based on fan speed.

Remote control setting fan speed	Cooling	Dry	Heating
Lo	+1.0°C	+1.0°C	+1.0°C
Me-, Me, Me+, Auto fan speed	+1.0°C		+1.0°C
Hi	+1.0°C		+1.0°C

### 8.2.3. Table c

Powerful Mode Shift

	Cooling	Dry	Heating
Powerful	-4.0°C	-3.0°C	+6.0°C



### 8.3. COMPRESSOR OPERATING FREQUENCY OPERATION

Compressor Operation Frequency According to Comp. Operation Frequency Command Number(INDOOR UNIT)

#### 8.3.1. Cooling & Soft Dry

(Unit : Hz)	Comp.Operation Frequency Command Number of Indoor Unit A																
	0	1	2	3	4	5	6	7	8	9	10	11	12	13	14	15	
Comp. Operation Frequency Command Number of Indoor Unit B	0	0	15	15	15	15	15	22	30	39	45	47	65	67	67	67	67
	1	15	30	30	39	43	45	47	50	52	56	57	61	61	61	61	61
	2	15	30	30	39	43	45	47	50	52	56	57	61	61	61	61	61
	3	15	39	39	41	45	47	48	52	54	57	59	63	63	63	63	63
	4	15	43	43	45	48	50	52	56	57	61	63	67	67	67	67	67
	5	15	45	45	47	50	52	54	57	59	63	65	68	68	68	68	68
	6	22	47	47	48	52	54	56	59	61	65	67	70	70	70	70	70
	7	30	50	50	52	56	57	59	63	65	68	70	74	74	74	74	74
	8	39	52	52	54	57	59	61	65	67	70	72	75	75	75	75	75
	9	45	56	56	57	61	63	65	68	70	74	75	75	75	75	75	75
	10	47	57	57	59	63	65	67	70	72	75	75	76	76	76	76	76
	11	65	61	61	63	67	68	70	74	75	75	76	77	77	77	77	77
	12	67	61	61	63	67	68	70	74	75	75	76	77	77	77	77	77
	13	67	61	61	63	67	68	70	74	75	75	76	77	77	77	77	77
	14	67	61	61	63	67	68	70	74	75	75	76	77	77	77	77	77
15	67	61	61	63	67	68	70	74	75	75	76	77	77	77	77	77	

Rated and Maximum Operation frequency

	Compressor Operation Frequency (Hz)	
	One Indoor Unit Operation	Two Indoor Units Operation
Fc (10)	47	75
Fc max (15)	67	77

#### 8.3.2. Heating

(Unit : Hz)	Comp.Operation Frequency Command Number of Indoor Unit A																
	0	1	2	3	4	5	6	7	8	9	10	11	12	13	14	15	
Comp. Operation Frequency Command Number of Indoor Unit B	0	0	15	25	35	45	55	55	65	69	74	75	93	106	118	118	118
	1	15	45	55	65	69	71	72	74	75	77	77	78	81	83	83	83
	2	25	55	65	69	71	72	74	75	77	78	78	80	83	84	84	84
	3	35	65	69	71	72	74	75	77	78	80	80	81	84	86	86	86
	4	45	69	71	72	74	75	77	78	80	81	81	83	86	87	87	87
	5	55	71	72	74	75	77	78	80	81	83	83	84	87	89	89	89
	6	55	72	74	75	77	78	80	81	83	84	84	86	89	90	90	90
	7	65	74	75	77	78	80	81	83	84	86	86	87	90	92	92	92
	8	69	75	77	78	80	81	83	84	86	87	87	89	92	93	93	93
	9	74	77	78	80	81	83	84	86	87	89	89	90	93	94	94	94
	10	75	77	78	80	81	83	84	86	87	89	90	92	93	100	100	100
	11	93	78	80	81	83	84	86	87	89	90	92	93	94	106	106	106
	12	106	81	83	84	86	87	89	90	92	93	93	94	106	112	112	112
	13	118	83	84	86	87	89	90	92	93	94	100	106	112	125	125	125
	14	118	83	84	86	87	89	90	92	93	94	100	106	112	125	125	125
15	118	83	84	86	87	89	90	92	93	94	100	106	112	125	125	125	

Rated and Maximum Operation frequency

	Compressor Operation Frequency (Hz)	
	One Indoor Unit Operation	Two Indoor Units Operation
Fh (10)	75	90
Fh max (15)	118	125

## 8.4. COOLING OPERATION

### 8.4.1. Room Temperature Control

1. When the remote control setting temperature is less than 24°C.

Cooling	Comp. Operation Frequency Command Number		
Intake air temp. – Internal setting temp.(°C)	+1.5	Fc(10) or Fc max(15)	Fc(10) or Fc max(15)
	+1.0	7	8
	+0.5	5	5
	0	2	3
Internal setting temp.	0	1	2
	-0.5	1	1
Thermostat OFF temp. –1.0	Thermostat OFF	Thermostat OFF	
Outdoor Air Temperature	Less than 38°C	38°C and above	

Refer to 8.3.2. Compressor Operation Frequency

2. When the remote control setting temperature is 24°C and above.

Cooling	Comp. Operation Frequency Command Number		
Intake air temp. – Internal setting temp.(°C)	+1.5	Fc(10) or Fc max(15)	Fc(10) or Fc max(15)
	+1.0	7	7
	+0.5	5	5
	0	2	2
Internal setting temp.	0	1	1
	-0.5	1	1
Thermostat OFF temp. –1.0	Thermostat OFF	Thermostat OFF	
Outdoor Air Temperature	Less than 38°C	38°C and above	

Refer to 8.3.1. Compressor Operation Frequency

- Thermostat OFF temperature = Thermostat ON temperature.
- The Comp. Operation Frequency Command can be changed every 30 seconds.
- 30 minutes from the start of the operation, the compressor is operating at Fc max.
- The Thermostat OFF when the intake air temperature reaches 1°C below internal setting temperature and continues for 3 minutes.
- When the Thermostat of both Indoor Units OFF, the Compressor stops.
- When the compressor stops, it will not begin operation for 3 minutes. (Time Delay Safety Control)
- When the intake air temperature reaches the Compressor ON temperature, the Compressor starts operation.
- When the compressor stops, the outdoor fan motor stops 30 seconds later.

## 8.4.2. Deodorizing Control

- This control is available during automatic fan speed for Cooling and Soft Dry Operation. It is not available during anti-freezing control.

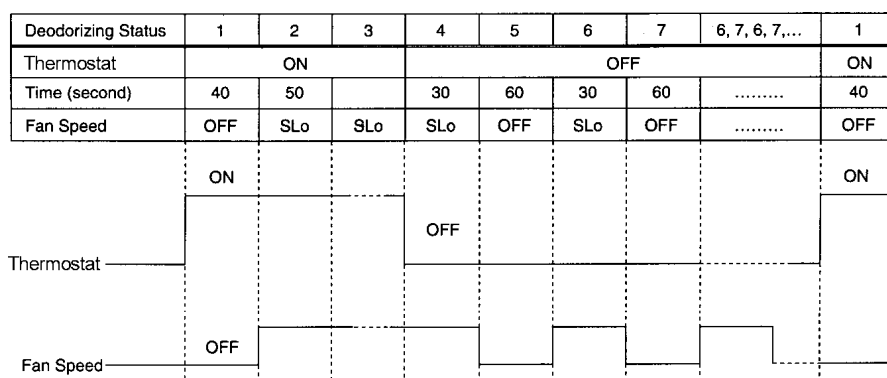

- When the Thermostat ON operation, the deodorizing status starts from 1 → 2 → 3.
- When the Thermostat OFF operation, the deodorizing status starts from 4 → 5 → 6 → 7.
- If the Thermostat OFF operation after 3 minutes, the deodorizing status will start from 6.

## 8.4.3. Sensible Heat Control

- This control is to improve the feeling in high fan speed during low Comp. Operation Frequency Command Number. When the Comp. Operation Frequency Command Number is less than 4, the fan speed will reduce. When the Comp. Operation Frequency Command Number is above 5 continuously for 5 minutes, the fan speed will resume to normal condition.

## 8.5. SOFT DRY OPERATION

### 8.5.1. Room Temperature Control

At the start of operation, cooling operation is running until the intake air temperature is 0.5°C higher than internal setting temperature, then the operation will shift to Soft Dry with indoor fan speed SLo.

Soft Dry	Comp. Operation Frequency Command Number	
Intake air temp. – Internal setting temp.(°C)	+1.5	
	+1.0	
	+0.5	
	0	
	-0.5	
Internal setting temp.	0	1
	-0.5	1
Thermostat OFF temp. –1.0	Thermostat OFF	
Outdoor Air Temperature	Less than 38°C	38°C and above

Refer to 8.3.1. Compressor Operation Frequency

- Thermostat OFF temperature = Thermostat ON temperature.
- The Comp. Operation Frequency Command can be changed every 30 seconds.
- 30 minutes from the start of the operation, the compressor is operating at Fc max.
- The Thermostat OFF when the intake air temperature reaches 1°C below internal setting temperature and continues for 3 minutes.
- When the Thermostat of both Indoor Units OFF, the Compressor stops.
- When the compressor stops, it will not begin operation for 3 minutes. (Time Delay Safety Control)
- When the intake air temperature reaches the Compressor ON temperature, the Compressor starts operation.
- When the compressor stops, the outdoor fan motor stops 30 seconds later.

### 8.5.2. Deodorizing Control

- This control is available during automatic fan speed for Cooling and Soft Dry Operation. It is not available during anti-freezing control.

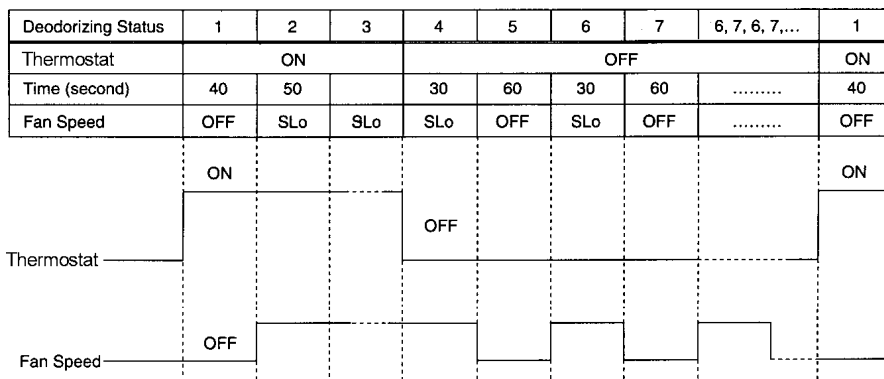

- When the Thermostat ON operation, the deodorizing status starts from 1 → 2 → 3.
- When the Thermostat OFF operation, the deodorizing status starts from 4 → 5 → 6 → 7.
- If the Thermostat OFF operation after 3 minutes, the deodorizing status will start from 6.

### 8.5.3. Sensible Heat Control

- This control is to improve the feeling in high fan speed during low Comp. Operation Frequency Command Number. When the Comp. Operation Frequency Command Number is less than 4, the fan speed will reduce. When the Comp. Operation Frequency Command Number is above 5 continuously for 5 minutes, the fan speed will resume to normal condition.

## 8.6. HEATING OPERATION

### 8.6.1. Room Temperature Control

- During heating operation, the room temperature control depends on intake air temperature and internal setting temperature. Basically it can be divided into 2 periods as shown below:

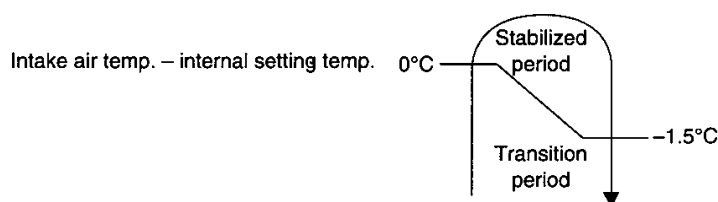

- When indoor fan speed is Medium or above.

Heating Operation	Comp. Operation Frequency Command Number						
	Transition Period	Stabilized Period					
Remote Control Setting Temp.	16°C~30°C	16°C~20°C		21°C~25°C		26°C~30°C	
Intake air temperature – Internal setting temperature Thermostat OFF temp.	Thermostat OFF	Thermostat OFF	Thermostat OFF	Thermostat OFF	Thermostat OFF	Thermostat OFF	Thermostat OFF
+1.5	1	1	1	1	1	1	1
+1.0	1	1	1	4	1	4	1
+0.5	6	3	3	6	3	6	3
0	8	4	4	7	4	7	4
-0.5	8	6	6	8	6	8	6
-1.0	9	7	7	9	7	9	7
-1.5	Fh(10) or Fh max(15)	Fh(10) or Fh max(15)	Fh(10) or Fh max(15)	Fh(10) or Fh max(15)	Fh(10) or Fh max(15)	Fh(10) or Fh max(15)	Fh(10) or Fh max(15)
Outdoor air temperature		Less than -1°C	-1°C and above	Less than -1°C	-1°C and above	Less than -1°C	-1°C and above

Refer to 8.3.2. Compressor Operation Frequency

- When indoor fan speed is lower than Medium.

Heating Operation	Comp. Operation Frequency Command Number						
	Transition Period	Stabilized Period					
Remote Control Setting Temp.	16°C~30°C	16°C~20°C		21°C~25°C		26°C~30°C	
Intake air temperature – Internal setting temperature Thermostat OFF temp.	Thermostat OFF	Thermostat OFF	Thermostat OFF	Thermostat OFF	Thermostat OFF	Thermostat OFF	Thermostat OFF
+1.5	1	1	1	1	1	1	1
+1.0	1	3	3	4	3	4	3
+0.5	6	4	4	6	4	6	4
0	8	6	6	7	6	7	6
-0.5	8	7	7	8	7	8	7
-1.0	9	9	9	9	9	9	9
-1.5	Fh(10) or Fh max(15)	Fh(10) or Fh max(15)	Fh(10) or Fh max(15)	Fh(10) or Fh max(15)	Fh(10) or Fh max(15)	Fh(10) or Fh max(15)	Fh(10) or Fh max(15)
Outdoor air temperature		Less than -1°C	-1°C and above	Less than -1°C	-1°C and above	Less than -1°C	-1°C and above

Refer to 8.3.2. Compressor Operation Frequency

- Thermostat OFF temperature = Thermostat ON temperature.
- The operation frequency changes every 30 seconds.
- When the difference of the intake air temperature and Internal setting temperature is  $-1.5^{\circ}\text{C}$  or more, compressor will operate at Fh continuously for 3 minutes and then change over to Fh max.
- The Thermostat OFF when the intake air temperature reaches  $1.5^{\circ}\text{C}$  above internal setting temperature and continues for 3 minutes.
- When the Thermostat of both Indoor Units OFF, the Compressor stops.
- When the compressor stops, it will not start operation for 3 minutes. (Time Delay Safety Control)
- When the intake air temperature decreases to the compressor ON temperature, the compressor starts immediately.
- When the compressor stops, the outdoor fan motor stops 30 seconds later.

### 8.6.2. Anti Cold Draft Control

#### 1. Indoor Fan Control

Indoor fan speed and airflow direction varies in accordance to the indoor heat exchanger temperature as shown below:

##### a. Manual Fan speed control

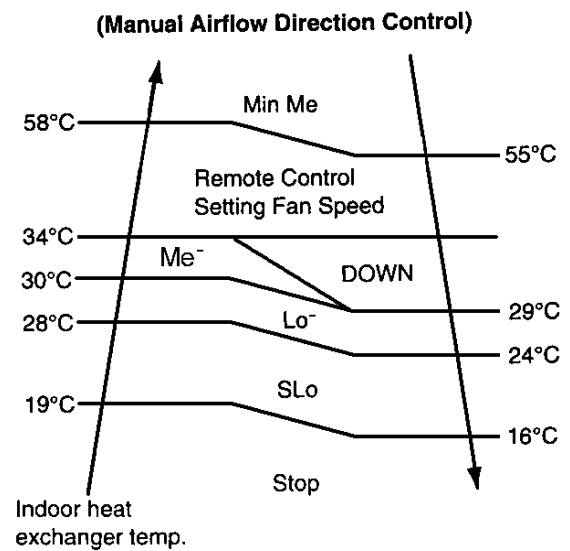
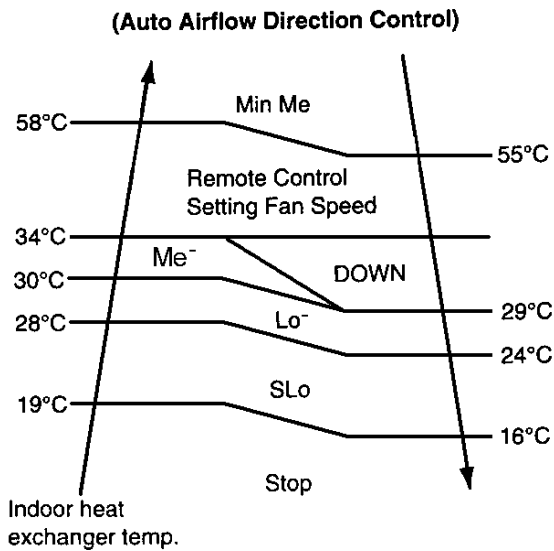

##### b. Auto Fan speed control

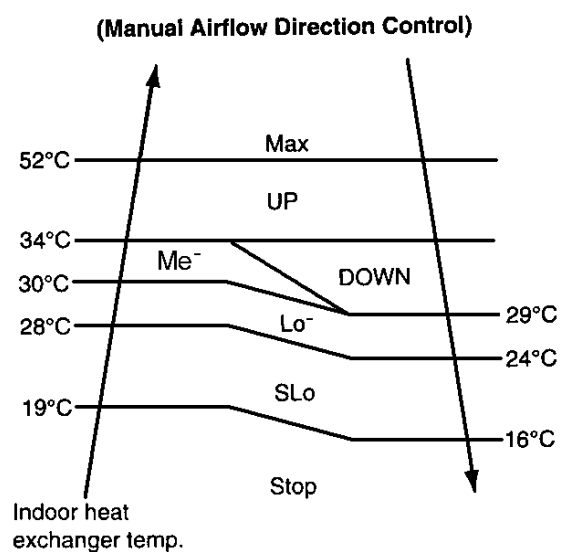
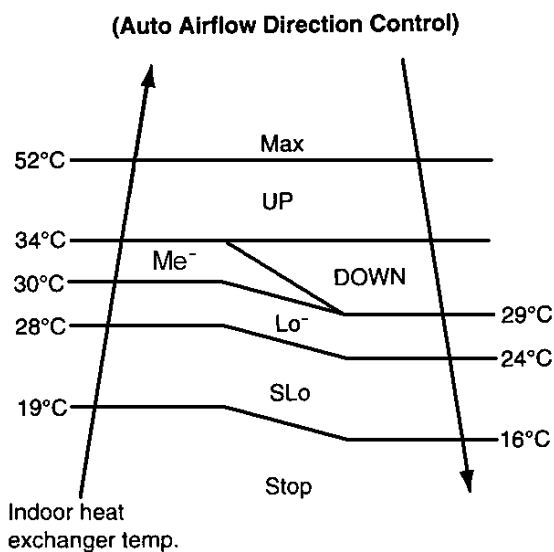

**Note:**

- UP means fan speed is increased by 1 rank.
- DOWN means fan speed is decreased by 1 rank.
- Max means fan speed is running at maximum auto fan speed.

## 2. Hot Start

- At the start of heating operation, the indoor fan stops and Comp. Operation Frequency Command Number at Fh max. This is to heat up the indoor heat exchanger in order to avoid cold air discharged.
- Hot Start ends when
  - a. Indoor heat exchanger temperature reaches over 15°C
  - or
  - b. 4 minutes after heating operation starts
- After Hot Start operation, Comp. Operation Frequency Command Number at Fh max for 2 minutes.

### 8.6.3. Standby Control

1. The purpose of Standby Control is to warm up the compressor when outdoor temperature is low. the standby control will be activated when all of the followings occur.
  - Unit is not operating.
  - Compressor temperature is below 7°C.
2. When the standby control is activated, low electricity will be supplied to compressor for 3 minutes and stops for 7 minutes. This condition is repeated until standby control is cancelled. It will consume about 35W of electric power.

Electricity supplied to compressor	ON	OFF	ON	OFF	.....
Time	3 min	7 min	3 min	7 min	.....

3. Standby control will be cancelled when one of the following conditions occurs.
  - Unit starts operation.
  - Compressor temperature is over 9°C.
4. When the unit is switched on by the remote control, the compressor operates at frequency as shown in below:-

Compressor operating frequency	Max.40Hz Min.38Hz	Max.48Hz Min.38Hz	Free
Time(sec)			

5. The standby control can be cancelled by cutting off the jumper wire on the outdoor electronic controller.

### 8.6.4. Deice Operation

Deice operation occurs when the deice operation starting signal is generated. This happens when one of the following conditions occurs. However, the first deice operation will begin 1 hour after start of heating operation.

	Outdoor Heat Exchanger Temp. Th < 3 °C	Outdoor Heat Exchanger Temp. (Th)	Outdoor Temp. (To)
Case 1	120 minutes continuously	Th < -6 °C for 3 min continuously	To ≤ -1 °C
Case 2	80 minutes continuously	Th < -7 °C for 3 min continuously	To ≤ -1 °C
Case 3	40 minutes continuously	Th < -9 °C for 3 min continuously	To ≤ -3 °C
Case 4	40 minutes continuously	Th < -11 °C for 3 min continuously	To < -3 °C

#### Note:

The above 4 cases are under compressor operating condition.

Deice Operation Time Chart

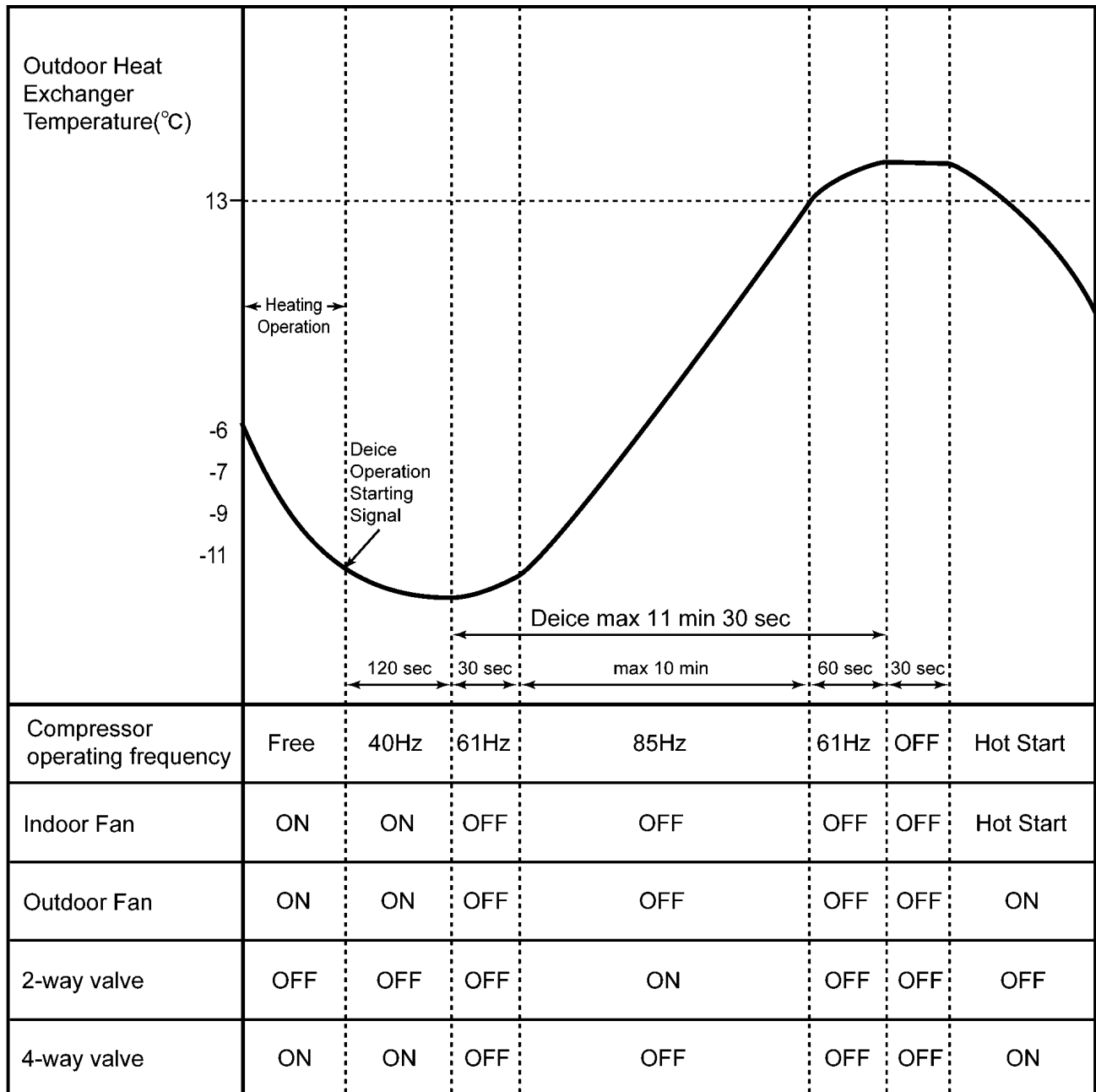

- Compressor frequency is set at 40Hz when the deice operation starting signal is generated.
- 120 seconds later deice operation starting signal is generated, indoor fan, outdoor fan, 4-way valve are turned off and compressor operates at 61Hz for 30 seconds. (Deice operation starts)
- During deice operation, the compressor operating frequency is set at 85Hz.
- Deice will end when the outdoor heat exchanger temperature rises to 13°C or after 11 min 30sec.



## 8.7. FAN OPERATION

This operation is to enable the fan operation without compressor running. Timer operation is valid for fan operation.

## 8.8. AUTOMATIC OPERATION

When the Automatic mode is selected, the operation mode is decided in accordance to remote control setting temperature, intake air temperature and outdoor air temperature.

- During judging the operation mode, indoor fan is running at Lo-speed and outdoor fan at ON in order to sense the indoor intake air temperature and outdoor air temperature for 20 seconds. At this time, Power LED is blinking. After the operation mode is selected, Power LED light up.

There are 4 determination charts when automatic mode is selected.

**(A) When setting temperature of remote control is 18 °C and below**

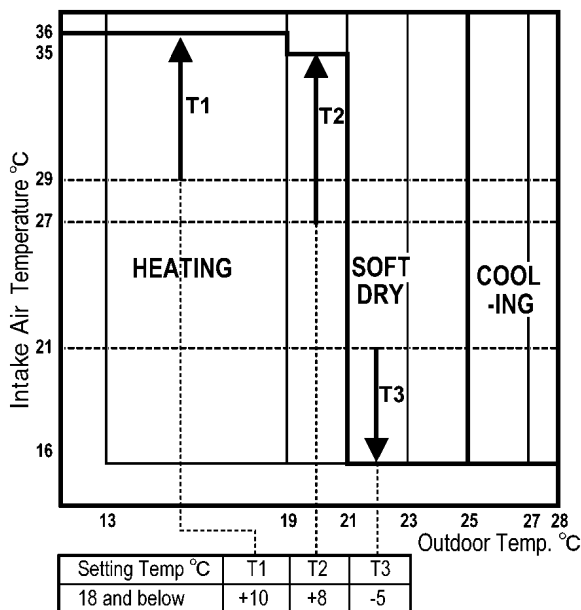

**(B) When setting temperature of remote control is 19 °C ~ 22 °C**

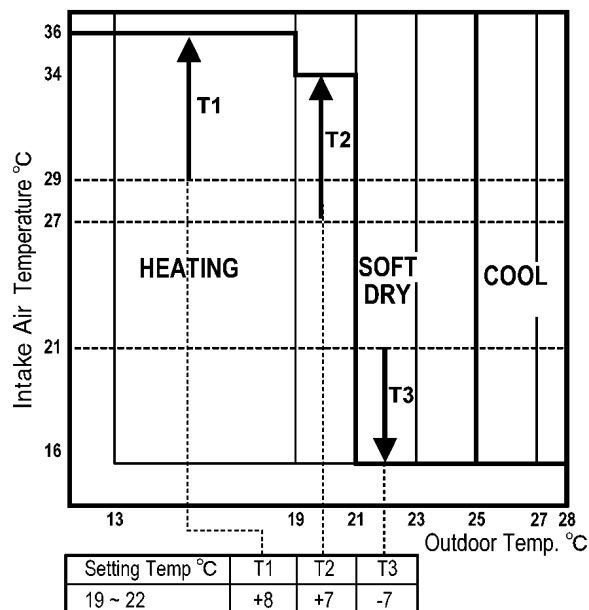

**(C) When setting temperature of remote control is 23 °C ~ 26 °C**

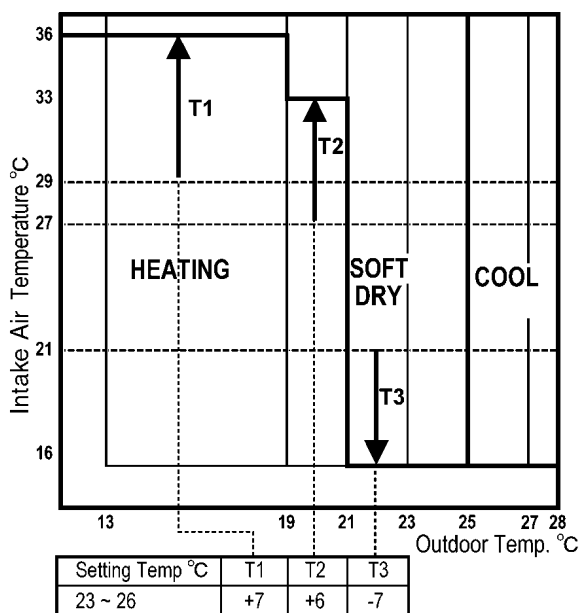

**(D) When setting temperature of remote control is 27 °C and above**

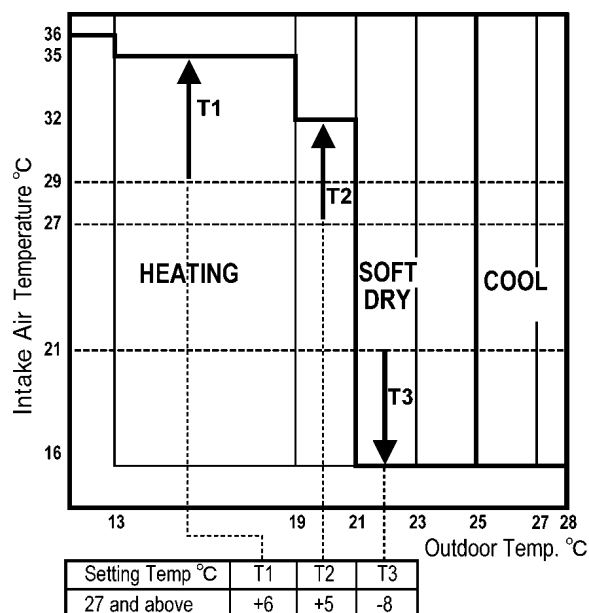

Setting temp °C	T1	T2	T3	Note:
18 and below	+10	+8	-5	Base temperature for T1 is 29 °C
19 - 22	+8	+7	-7	Base temperature for T2 is 27 °C
23 - 26	+7	+6	-7	Base temperature for T3 is 21 °C
27 and above	+6	+5	-8	

- When the operation mode is changed over, the value for t1, t2 and t3 are shifted as follows:  
Cooling/Soft dry → Heating: -2°C  
Heating → Cooling/Soft dry: +2°C
- When the indoor intake air temperature is lower than 16°C, heating operation is immediately started.
- When the outdoor air temperature is more than 25°C, and the intake air temperature is over 16°C, cooling operation is immediately started.
- The operation mode is judged every 3 hours.

### 8.8.1. Temperature Shift

- When the operation mode (Heating, Cooling or Soft Dry) is decided, the internal setting temperature will shift as shown below:

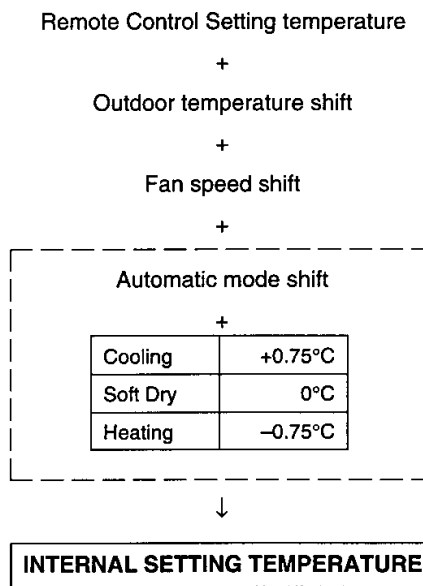

## 8.9. INDOOR FAN SPEED CONTROL

Fan speed no.	Voltage Supply to Fan Motor DC(V)	Cooling		Soft Dry	Remarks	Heating		Remarks
		Manual	Auto			MAnnual	Auto	
0		OFF	OFF	OFF		OFF	OFF	• hot Start Control
2	13.0			SLO	• Deodorizing control • Sleep Mode			• Slo:Hot Start Control
3	13.7		Lo-		• Auto operation mode judgement • Quiet operation			• Lo-:Hot Start Control • Sleep Mode • Thermo OFF • Anti Cold Draft Control
6	16.0	Lo			• Sensible Heat Control • On Timer preparatory operation + Auto Fan			
8	18.2					Lo		• On Timer preparatory operation + Auto Fan
9	19.1				• Manual Fan + Powerful • On Timer preparatory operation + Manual Fan + powerful			
10	20.6	Me-			• Sensible Heat Control • Sensible Heat Control + Auto Fan	Me-	Auto Fan (Min)	
11	21.5		Auto Fan					• Auto Fan + Powerful
12	21.8	Me			• Manual Fan + Powerful • On Timer preparatory operation + Manual Fan + powerful • Sensible Heat Control + Auto Fan	Me		• Manual Fan + Powerful • On Timer preparatory operation + Manual Fan + Powerful • Temporary Operation
13	22.7		Auto Fan		• Sensible Heat Control • Auto Fan + Powerful			
14	23.6				• Manual Fan + Powerful • On Timer preparatory operation + Manual Fan + powerful • Sensible Heat Control + Auto Fan			
15	23.9		Auto Fan		• Auto Fan + Powerful			
16	24.5				• Sensible Heat Control			
17	25.1				• Auto Fan + Powerful			
19	26.0	Me+						
21	26.6				• Manual Fan + Powerful • On Timer preparatory operation + Manual Fan + powerful	Me+		
22	27.2	Hi			• Test Run		Auto Fan (Max.)	
27	29.5							• Auto Fan + Powerful
28	29.9				• SHi:Maximum Capacity Operation • Manual Fan + Powerful • On Timer preparatory operation + Manual Fan + powerful			
30	33.2					SHI		• Manual Fan + Powerful • On Timer preparatory operation + Manual Fan + Powerful • Test Run
31	33.8							• SSHI:Maximum Capacity Operation

### 1. Cooling Automatic Fan Speed

The Automatic Fan Speed for cooling operation is shown as below:

a. When Automatic Fan Speed is selected

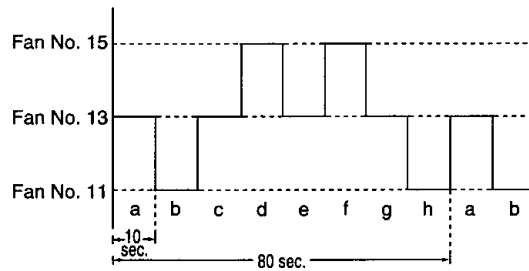

b. When Automatic Fan Speed and Powerful Mode are selected

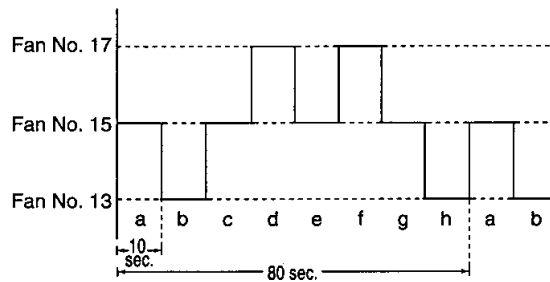

**Note:**

The Fan Speed will change every 10 seconds and it will be repeated from a to h every 80 seconds.

### 2. Heating Automatic Fan Speed

The Automatic Fan Speed for heating operation is shown below:

- When Automatic Fan Speed is selected, the Fan speed will change every 10 seconds from Fan Speed No. 10 to No. 22 depending on indoor heat exchanger temperature. Each time the Fan Speed will move 1 rank up or down.
- When Automatic Fan Speed and Powerful Mode are selected, the Fan Speed will change for every 10 seconds from Fan Speed No. 11 to No. 27 depend on heat exchanger temperature. Each time the Fan Speed will move 1 rank up or down.

### 3. Cooling Operation at SHi Speed

During Cooling operation, Indoor Fan speed is set at SHi when the following conditions occur:

- Outside air temperature is 30°C or above
- Compressor operates at One Unit operation : 47Hz and above, Two Units operation : 75Hz and above
- Remote control setting fan speed is High
- Indoor intake air temperature is 24°C or above
- Remote control setting temperature is 16°C
- Within 30 minutes after start of operation.

### 4. Heating Operation at SSHi Speed

During Heating operation, Indoor Fan speed is set at SSHi when the following conditions occur:

- Heating operation for 2 hours or more
- When remote control setting fan speed is High
- Indoor intake air temperature is 17°C or above and less than 23°C
- Outdoor air temperature is 4°C or below
- Remote control setting temperature is 30°C
- Compressor operates at One Unit operation : 75Hz and above, Two Units operation : 90Hz and above
- Airflow Direction is set at Manual.

## 8.10. OUTDOOR FAN CONTROL

- Outdoor fan motor is controlled with 1 speeds. Fan is in operation when the compressor starts operation and stops 30 seconds after compressor stops operation.

## 8.11. AIRFLOW DIRECTION

- Blade angle setting (Upper limit reference)

Operation				Blade angle				
				1	2	3	4	5
heating	Airflow direction auto	Indoor heat exchanger temperature	C	33°				
			B	70°				
			A	15°				
	Airflow direction manual	-	-	13°	33°	46°	57°	70°
Cooling	Airflow direction auto	-	7° - 36°					
		Anti-dew formation control	11° - 25°					
	Airflow direction manual	-	7°	15°	25°	33°	41°	
		Anti-dew formation control	11°	15°	18°	22°	25°	
Dry	Airflow direction auto	-	3° - 33°					
		Anti-dew formation control	11° - 25°					
	Airflow direction manual	-	3°	8°	18°	25°	33°	
		Anti-dew formation control	11°	15°	18°	22°	25°	
Fan	Airflow direction auto	-	7° - 36°					
	Airflow direction manual	-	7°	15°	25°	33°	41°	
Stop				143°				

- Sitting angle

Cooling, Soft Dry & Fan – Auto Airflow Direction

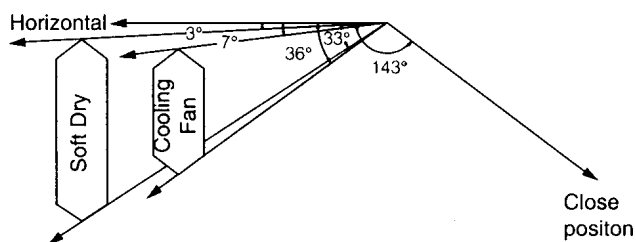

Heating – Auto Airflow Direction

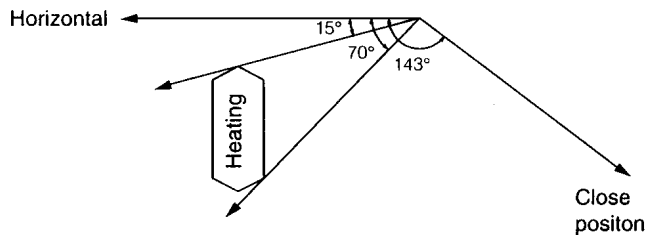

Cooling, Soft Dry & Fan – Manual Airflow Direction

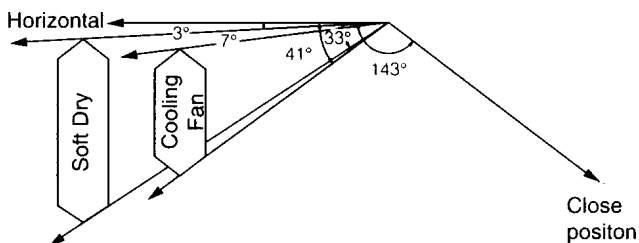

Heating – Manual Airflow Direction

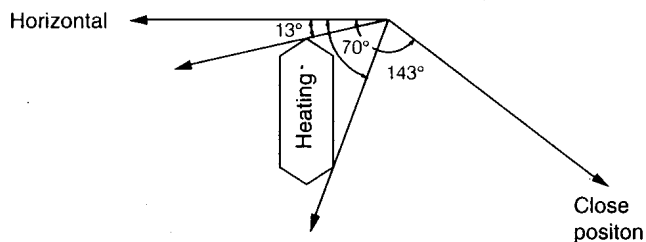

1. Airflow Direction Manual

By pressing the remote control airflow direction setting switch, the blade will move to the indicated angle (1, 2, 3, 4, 5) as shown in the table. When the remote control OFF/ON switch is pressed, the blade will move to the Close position.

2. Airflow Direction Auto

By setting the airflow direction to AUTO, the blade swings up and down from 7°-36° (during Cooling and Fan) and 3°-33° (during Soft Dry). During Heating operation, the blade angle will shift according to the indoor heat exchanger temperature as shown below:

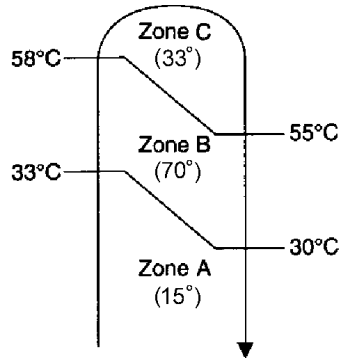

## 8.12. QUIET OPERATION

The purpose of this control is to reduce indoor operating noise. Indoor fan speed is set to Lo- when the following conditions occur.

- Indoor fan speed is set at Low
- Indoor heat exchanger temperature rises to 17°C or above
- Compressor operates for 5 minutes or above
- Comp. Operation Frequency Command Number is less than 5

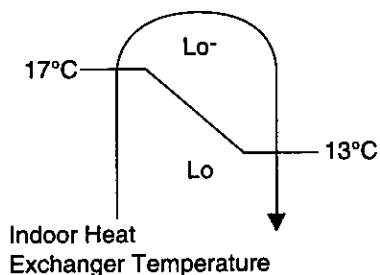

When the indoor heat exchanger temperature is decreased to 13°C or below, the control is cancelled and the indoor fan speed will resume from Lo- to Low.

## 8.13. POWERFUL MODE OPERATION

When the powerful mode is selected, the internal setting temperature will shift to achieve the setting temperature quickly.

### 1. Cooling Operation

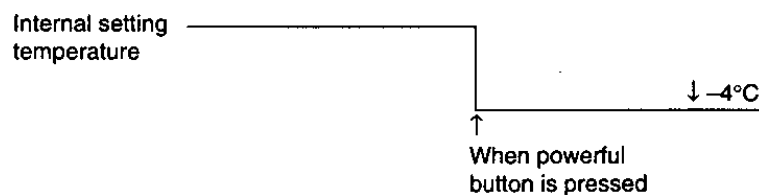

### 2. Soft Dry Operation



### 3. Heating Operation



## 8.14. SLEEP MODE OPERATION

### 1. Cooling Operation/Soft Dry Operation

- When the sleep button is pressed, the remote control setting temperature will increase  $0.5^{\circ}\text{C}$  after 1 hour or when the remote control setting temperature is reached. After another hour,  $0.5^{\circ}\text{C}$  will be increased again.

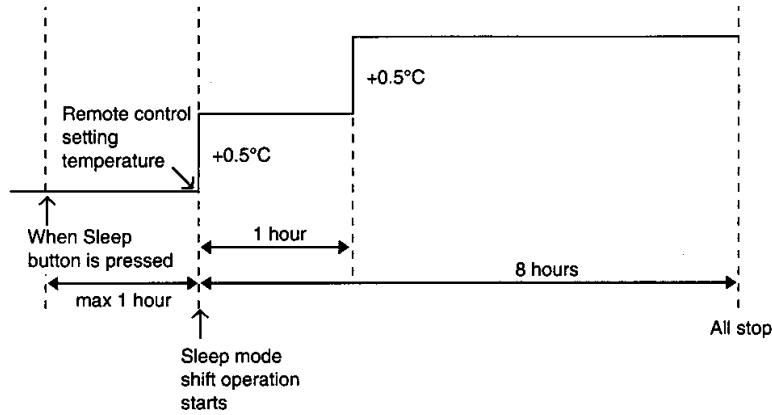

- During sleep shift operation, indoor fan speed operates at SLo.

### 2. Heating Operation

- When the sleep button is pressed, the remote control setting temperature will decrease  $2^{\circ}\text{C}$  after 1 hour or when the remote control setting temperature is reached. After another hour,  $3^{\circ}\text{C}$  will be decreased again.

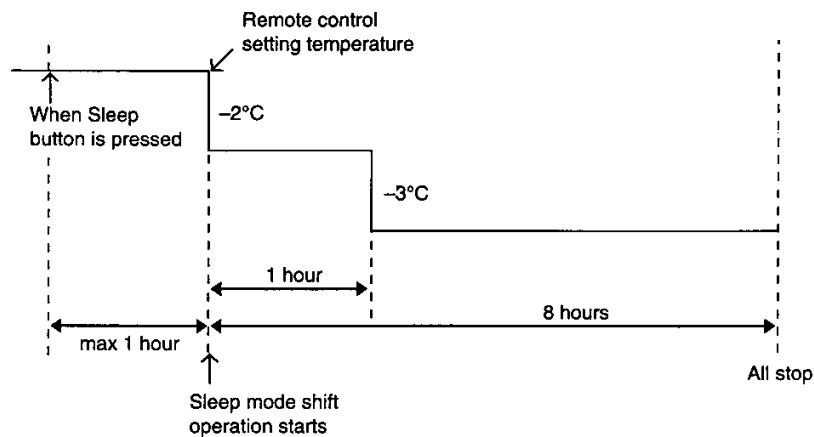

- During sleep shift operation, indoor fan speed operates at Lo.



## 8.15. DELAY ON TIMER CONTROL

- When the Delay On Timer is set by using remote control, the unit will start to operate slightly earlier before the set time, so that the room will nearly reach the set temperature by the On Timer set time.
- 60 minutes before the set time, the indoor fan operates at SLo and outdoor fan operates for 20 seconds to sample the indoor intake air temperature and outdoor air temperature in order to determine the starting time for preparatory operation. (The Power LED blinks during sampling.)
- The time of the preparatory operation will start before the On Timer set time.
  1. Cooling/Soft Dry

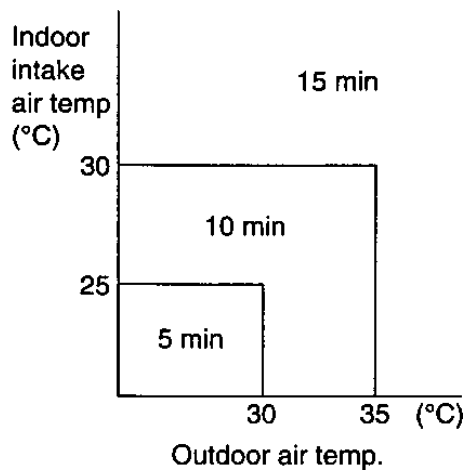

### 2. Heating

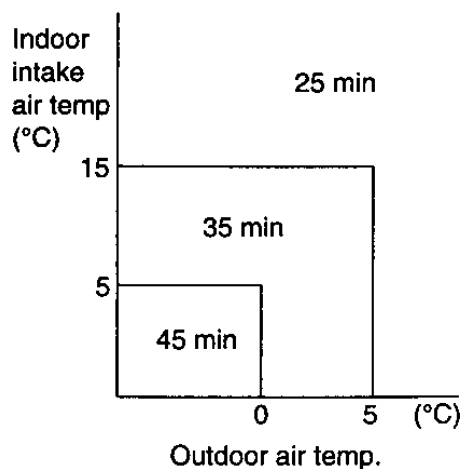

## 8.16. AUTO RESTART CONTROL

- If there is a power failure, operation will automatically be restarted when the power is resumed. It will start with the previous operation mode and airflow direction. (Time Delay Safety Control is valid)
- Auto Restart Control is not available when Timer or Sleep Mode is set.

## 8.17. POWER MONITOR DISPLAY

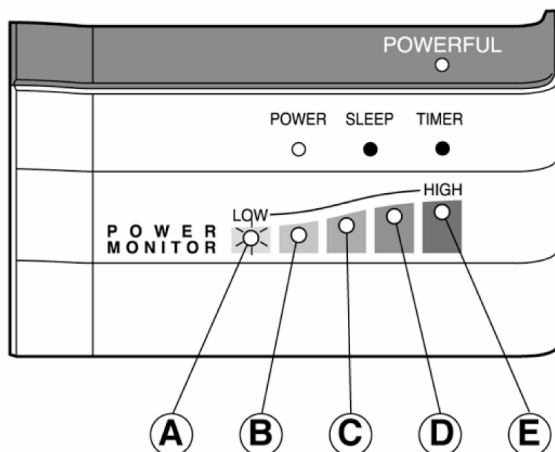

Power Monitor LED lights on when the compressor is in operation. The number of the LED lights on is in accordance to the Comp. Operation Frequency Command Number.

Display	A	A, B	A, B, C	A, B, C, D	A, B, C, D, E
Cooling & Soft Dry Indication Comp. Operation Frequency Command Number	1-4	5-6	7-8	9	10-15
Heating Indication Comp. Operation Frequency Command Number	1-3	4-5	6-7	8-9	10-15

## 8.18. REMOTE CONTROL SIGNAL RECEIVING SOUND ON/OFF

- Press the AUTO button for 10 seconds or longer to switch off the signal receiving sound.
- Press the AUTO button for 10 seconds or longer again to switch on the signal receiving sound.

## 9 Operation Details (PROTECTION)

### 9.1. PROTECTION CONTROL FOR ALL OPERATIONS

#### 1. Time Delay Safety Control

- The compressor is not restarted for 3 minutes after stop of compressor.

#### 2. 30 Second Forced Operation

- Once the compressor is ON, it will not turn OFF for 30 seconds. However, it is turned off by remote control or Automatic switch.

#### 3. Total Running Current Control

- When the outdoor unit total running current (AC) exceeds  $I_1$ , the frequency is lowered by 1 rank. If  $I_1$  is not exceeded for 30 seconds, the frequency is highered by 1 rank at one time. If the outdoor unit total running current exceeds  $I_2$ , the compressor is immediately stopped for 3 minutes.

< Cooling, Soft Dry set value >

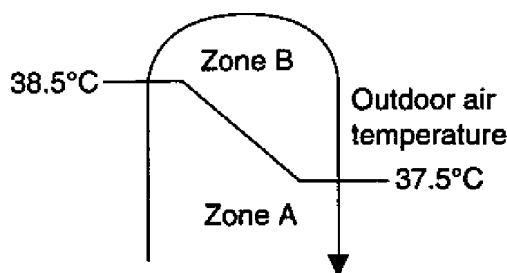
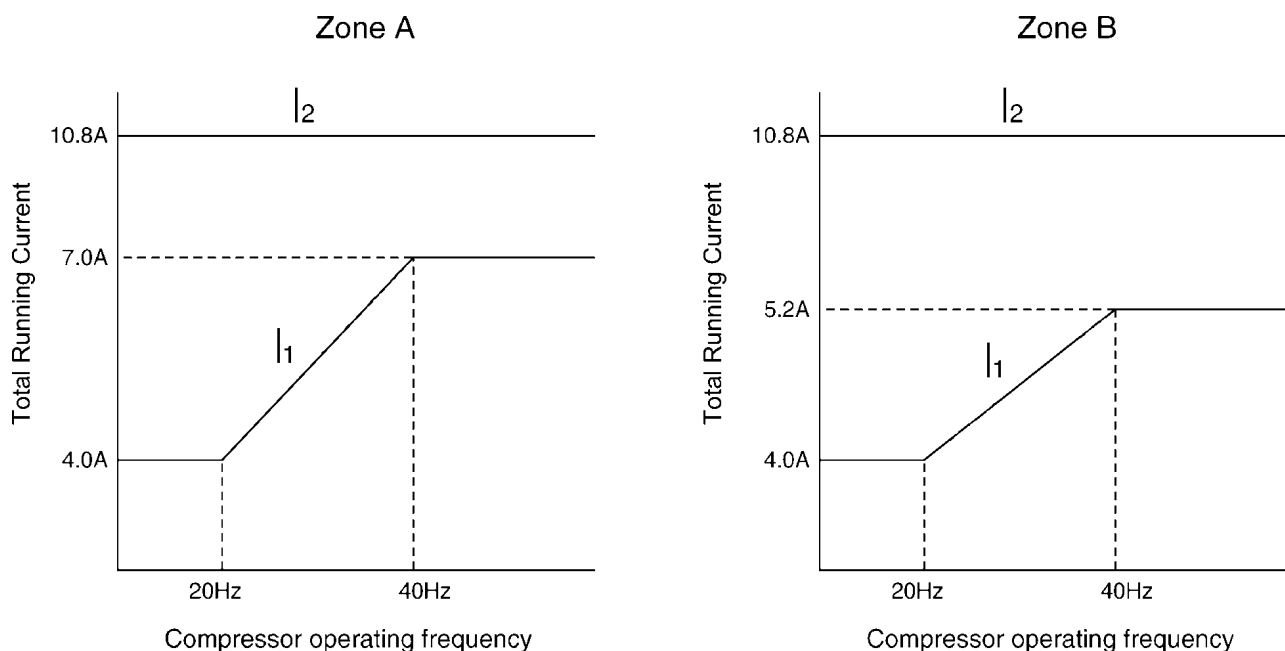

#### Note:

Zone A will be used 30 minutes after operation starts.

< Heating set value >

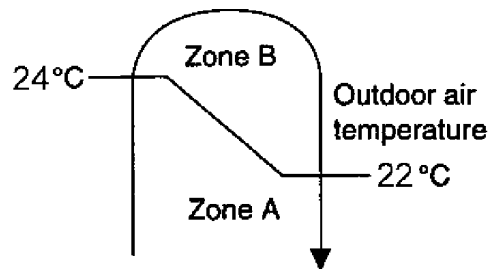
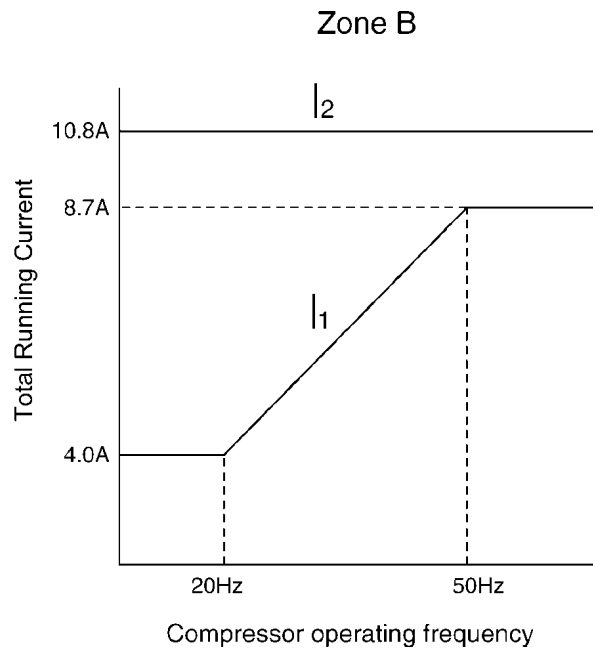
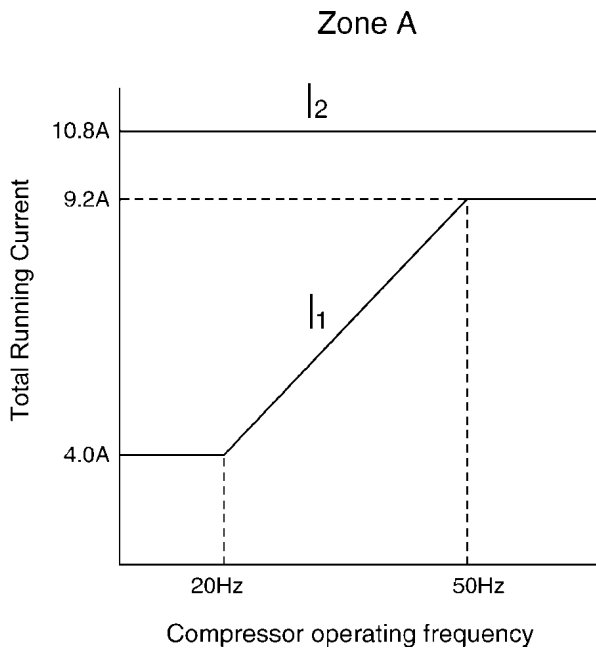

4. Power Transistor Overheating Prevention Control

- When the power transistor temperature rises to 110°C, the OLP goes into operation and compressor stops immediately. The compressor is restarted when the power transistor temperature decreases to 95°C after 3 minutes (Time Delay Safety Control).

5. Compressor Overheating Prevention Control

- When the temperature of compressor rises to 105°C, the frequency is reduced as shown in diagram below. When the temperature rises to 112° or above, the compressor stops. The compressor will start operating at low frequency when the temperature falls to 112°C and resume to normal condition when the temperature falls to 94°C.

Compressor Temp.(°C)	112	Comp OFF max 70Hz	Comp OFF max 70Hz
	105		
	94	Free	Free
Condition	When temperature rises		When temperature falls

## 6. Low Pressure Control (Gas Leakage Detection)

- When the following conditions as shown in the below table occur, the compressor stops and restarts after 3 minutes. If this phenomenon is continuously occurring twice within 20 minutes, the air conditioner will stop operation and the Timer LED blinks. At this time, [F91] is displayed on the indoor unit.

Comp. Frequency ☒	75Hz	92Hz
Total Running Current ☒	$\geq 1.51$ A and $\leq 2.8$ A	$\geq 1.51$ A and $\leq 3.1$ A
Indoor Heat Exchanger Temp.	20 °C or above	25 °C or below
Operation	Cooling / Soft Dry	Heating

### Note:

The above conditions are not valid during Deice operation.

- this conditions are continuous for 5 minutes.

## 7. Minimum Frequency Operation Protection

- When the compressor operates at less than 30Hz for 60 minutes, the operating frequency will increase to 35Hz for 2 minutes.

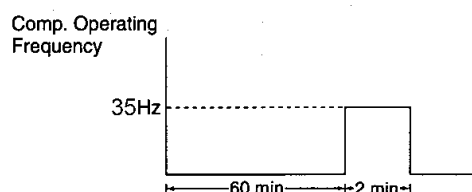

## 8. DC Peak Current Control

- When the electric current to the power transistor exceeds the set value, DC  $24 \pm 3$ A, the compressor stops. The compressor restarts after 3 minutes.
- If within 30 seconds the set value exceeds again, the compressor will stop for 1 minute. If this condition repeats 7 times, all indoor and outdoor relays will be turned off; TIMER LED will blink and F99 is displayed.

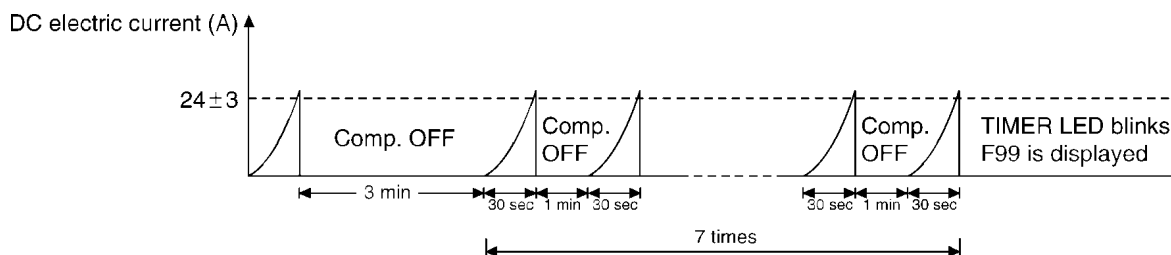

## 9. DC Reset

- When the voltage supply (DC) to power transistor is below the set value i.e.,  $178 \pm 5$ V, the compressor is stopped. The compressor will restart after 3 minutes.
- If within 30 seconds the voltage supply (DC) is below the set value again after start of the compressor, all indoor and outdoor relays will be turned off and all the LEDs will blink.

## 10. High Power Supply Voltage Protection

- When the voltage supply (AC) exceeds  $295 \pm 15$ V( $T_0$ ), the air conditioner stops and restarts automatically when the voltage supply (AC) is below ( $T_0 - 5$ )V. However, waiting for 3 minutes is necessary for re-operation.

11. Outdoor Air Temperature Control

• The compressor operating frequency is regulated in accordance to the outdoor air temperature.

< Cooling, Soft Dry >

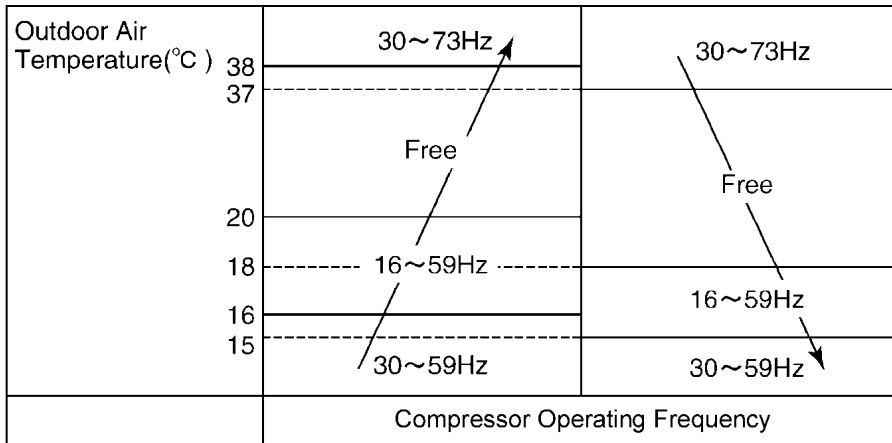

< Heating >

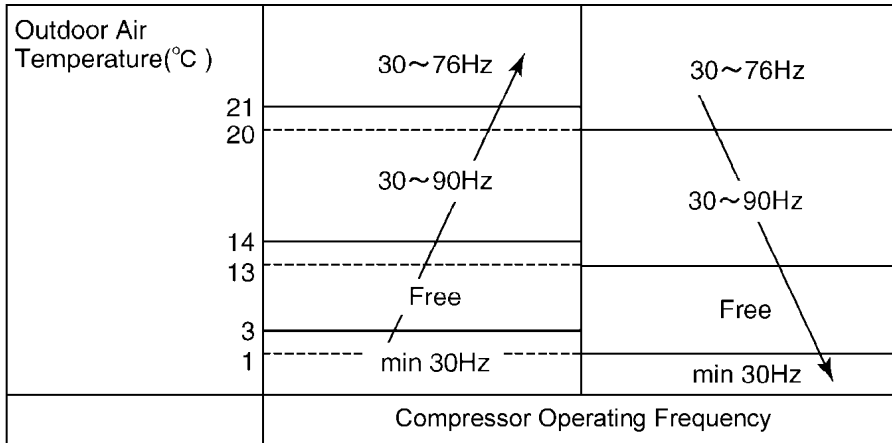

12.2 way valve control ( Protection of compressor )

- When the 2 way valve is ON at
  - a. 15 seconds later after the compressor started operation.  
( ON time of 2 way valve is 45 seconds. )
  - b. During Deice operation.
- The 2 way valve is OFF at during normal operation.

## 9.2. PROTECTION CONTROL FOR COOLING & SOFT DRY

### 1. Anti-Freezing Control

- When the temperature of the indoor heat exchanger becomes low, the compressor operating frequency is reduced and stopped when the temperature falls to lower than 2°C continuously for 6 minutes. This is to prevent freezing of indoor heat exchanger. When the temperature rises to 4°C or above, thermostat OFF with 3 minutes. The compressor operating frequency will resume to normal when the temperature reaches 14°C.
- Indoor fan speed will increase when the temperature falls and it will resume to original speed when the temperature increases to 14°C for 5 minutes continuously.

Indoor heat Exchanger Temp.(°C)	14			Free	Original
	6	Free	Original	8	Original
	4	8	1 rank up	4	1 rank up
	2	4		OFF	
		OFF			
	Comp. Operation Frequency Command Number	Indoor Fan	Comp. Operation Frequency Command Number	Indoor Fan	
	When the temp. falls		When the temp. rises		

Refer to 8.3.2. Compressor Operation Frequency

#### Note:

The above phenomenon occurs when the fan is running at Me+ or below.

### 2. Anti-Dew Formation Control

- When the following conditions occur for 20 minutes continuously, anti-dew formation is controlled:
  - Indoor intake air temperature is 24°C or above.
  - Outdoor air temperature is less than 30°C.
  - Remote control setting temperature is less than 25°C.
- During anti-dew formation control, compressor Operation Frequency Command Number at 8 and vertical airflow direction blade moves down slightly (as shown in Airflow Direction Control). Indoor fan speed increases by 1 rank if it is set at Low or below or decreases by 2 ranks if it is set at Hi speed.
- This control is cancelled immediately when either condition 1-3 as written above is changed, or remote control setting temperature or fan speed is changed.

### 3. Anti-Fog Discharge Control

- The compressor operating frequency is regulated by outdoor air temperature and operation time to prevent fog discharged from indoor unit as shown in the table below.

		Comp. Operation Frequency Command Number	
Operation Time, T (min)	$0 \leq T < 30$	10	10
	$30 \leq T < 90$	8	8
	$90 \leq T < 180$	8	8
	$T \geq 180$	8	8
Outdoor air temperature(°C)		Less than 24°C	24°C and above

#### Note:

- Indoor fan is running at Me+ or below.
- After 420 minutes from the start of operation, the operation timer counting is restarted from "0".

### 4. Anti-dew formation control

- The expansion valve is controlled to maintain the temperature difference between at center of heat exchanger ( pipe temperature 1 ) and at inlet of heat exchanger ( pipe temperature 2 ) will be less than 4°C.

### 9.3. PROTECTION CONTROL FOR HEATING OPERATION

1. Intake Air Temperature Control

- When the intake air temperature is 10°C or above and remote control setting fan speed is less than Medium, the compressor operates at 92Hz.

2. High Pressure Control

- The compressor operating frequency is regulated in accordance to the indoor heat exchanger temperature.

Indoor heat exchanger temp.(°C )	59	OFF	OFF
	53	45Hz	45Hz
	51	Min 45Hz	Max 62Hz
	47		Max 67Hz
	43	Free	Min 45Hz
	37		Free
Condition		When temp. rises	When temp. falls



# 10 Installation And Servicing Air Conditioner Using R410A

## 10.1. OUTLINE

### 10.1.1. About R410A Refrigerant

#### 1. Converting air conditioners to R410A

Since it was declared in 1974 that chlorofluorocarbons (CFC), hydro chlorofluorocarbons (HCFC) and other substances pose a destructive danger to the ozone layer in the earth's upper stratosphere (20 to 40 km above the earth), measures have been taken around the world to prevent this destruction.

The R22 refrigerant which has conventionally been used in ACs is an HCFC refrigerant and, therefore, possesses this ozone-destroying potential. International regulations (the Montreal Protocol on Ozone-Damaging Substances) and the domestic laws of various countries call for the early substitution of R22 by a refrigerant which will not harm the ozone layer.

In ACs, the HFC refrigerant which has become the mainstream alternative is called R410A. Compared with R22, the pressure of R410A is approximately 1.6 times as high at the same refrigerant temperature, but the energy efficiency is about the same. Consisting of hydrogen (H), fluorine (F) and carbon (C), R410A is an HFC refrigerant. Another typical HFC refrigerant is R407C. While the energy efficiency of R407C is somewhat inferior to that of R410A, it offers the advantage of having pressure characteristics which are about the same as those of R22, and is used mainly in packaged ACs.

#### 2. The characteristics of HFC (R410A) refrigerants

##### a. Chemical characteristics

The chemical characteristics of R410A are similar to those of R22 in that both are chemically stable, non-flammable refrigerants with low toxicity.

However, just like R22, the specific gravity of R410A gas is heavier than that of air. Because of this, it can cause an oxygen deficiency if it leaks into a closed room since it collects in the lower area of the room. It also generates toxic gas when it is directly exposed to a flame, so it must be used in a well ventilated environment where it will not collect.

Table 1 Physical comparison of R410A and R22

	R410A	R22
Composition (wt%)	R32/R125 (50/50)	R22 (100)
Boiling point (°C)	-51.4	-40.8
Vaporizing pressure (25°C)	1.56 Mpa (15.9 kgf/cm <sup>2</sup> )	0.94 Mpa (9.6 kgf/cm <sup>2</sup> )
Saturated vapor density	64.0 kg/m <sup>3</sup>	44.4 kg/m <sup>3</sup>
Flammability	Non-flammable	Non-flammable
Ozone-destroying point (ODP)	0	0.055
Global-warming point (GWP)	1730	1700

##### b. Compositional change (pseudo-azeotropic characteristics)

R410A is a pseudo-azeotropic mixture comprising the two components R32 and R125. Multi-component refrigerants with these chemical characteristics exhibit little compositional change even from phase changes due to vaporization (or condensation), which means that there is little change in the circulating refrigerant composition even when the refrigerant leaks from the gaseous section of the piping.

Accordingly, R410A can be handled in almost the same manner as the single-component refrigerant R22.

However, when charging, because there is a slight change in composition between the gas phase and the liquid phase inside a cylinder or other container, charging should basically begin with the liquid side.

##### c. Pressure characteristics

As seen in Table 2, the gas pressure of R410A is approximately 1.6 times as high as that of R22 at the same refrigerant temperature, which means that special R410A tools and materials with high-pressure specifications must be used for all refrigerant piping work and servicing.

Table2 Comparison of R410A and R22 saturated vapor density

Refrigerant Temperature(°C)	Unit:MPa	
	R410A	R22
-20	0.30	0.14
0	0.70	0.40
20	1.35	0.81
40	2.32	1.43
60	3.73	2.33
65	4.15	2.60

##### d. R410A refrigerating machine oil

Conventionally, mineral oil or a synthetic oil such as alkylbenzene has been used for R22 refrigerating machine oil. Because of the poor compatibility between R410A and conventional oils like mineral oil, however, there is a tendency for the refrigerating machine oil to collect in the refrigerating cycle. For this reason, polyester and other synthetic oils which have a high compatibility with R410A are used as refrigerating machine oil.

Because of the high hygroscopic property of synthetic oil, more care must be taken in its handling than was necessary with

conventional refrigerating machine oils. Also, these synthetic oils will degrade if mixed with mineral oil or alkylbenzene, causing clogging in capillary tubes or compressor malfunction. Do not mix them under any circumstances.

### 10.1.2. Safety Measures When Installing/Serviceing Refrigerant Piping

Cause the gas pressure of R410A is approximately 1.6 times as high as that of R22, a mistake in installation or servicing could result in a major accident. It is essential that you use R410A tools and materials, and that you observe the following precautions to ensure safety.

1. Do not use any refrigerant other than R410A in ACs that have been used with R410A.
2. If any refrigerant gas leaks while you are working, ventilate the room. Toxic gas may be generated if refrigerant gas is exposed to a direct flame.
3. When installing or transferring an AC, do not allow any air or substance other than R410A to mix into the refrigeration cycle. If it does, the pressure in the refrigeration cycle can become abnormally high, possibly causing an explosion and/or injury
4. After finishing the installation, check to make sure there is no refrigerant gas leaking.
5. When installing or transferring an AC, follow the instructions in the installation instructions carefully. Incorrect installation can result in an abnormal refrigeration cycle or water leakage, electric shock, fire, etc.
6. Do not perform any alterations on the AC unit under any circumstances. Have all repair work done by a specialist. Incorrect repairs can result in an water leakage, electric shock, fire, etc.

## 10.2. TOOLS FOR INSTALLING/SERVICING REFRIGERANT PIPING

### 10.2.1. Necessary Tools

In order to prevent an R410A AC from mistakenly being charged with any other refrigerant, the diameter of the 3-way valve service port on the outdoor unit has been changed. Also, to increase its ability to withstand pressure, the opposing dimensions have been changed for the refrigerant pipe flaring size and flare nut. Accordingly, when installing or servicing refrigerant piping, you must have both the R410A and ordinary tools listed below.

Table 3 Tools for Installation, transferring or replacement

Type of work	Ordinary tools	R410A tools
Flaring	Flaring tool (clutch type), pipe cutter, reamer	Copper pipe gauge for clearance Adjustment, flaring tool (clutch type)*1)
Bending, connecting pipes	Torque wrench (nominal diameter 1/4,3/8,1/2) Fixed spanner (opposing sides 12 mm, 17 mm, 19 mm) Adjustable wrench, Spring bender	
Air purging	Vacuum pump Hexagonal wrench (opposing sides 4 mm)	Manifold gauge, charging hose, vacuum pump adaptor
Gas leak inspection	Gas leak inspection fluid or soapy water	Electric gas leak detector for HFC refrigerant*2)

\*1). You can use the conventional (R22) flaring tool. If you need to buy a new tool, buy the R410A type.

\*2). Use when it is necessary to detect small gas leaks.

For other installation work, you should have the usual tools, such as screwdrivers (+,-), a metal-cutting saw, an electric drill, a hole core drill (65 or 70 dia.), a tape measure, a level, a thermometer, a clamp meter, an insulation tester, a voltmeter, etc.

Table 4 Tools for servicing

Type of work	Ordinary tools	R410A tools
Refrigerant charging		Electronic scale for refrigerant charging Refrigerant cylinder Charging orifice and packing for refrigerant cylinder
Brazing (Replacing refrigerating cycle parts*1)	Nitrogen blow set (be sure to use nitrogen blowing for all brazing), and brazing machine	

\*1). Always replace the dryer of the outdoor unit at the same time. The replacement dryer is wrapped in a vacuum pack. Replace it last among the refrigerating cycle parts. Start brazing as soon as you have opened the vacuum pack, and begin the vacuuming operation within 2 hours.

## 10.2.2. R410A Tools

1. Copper tube gauge for clearance adjustment  
(used when flaring with the conventional flaring tool (clutch type))
  - This gauge makes it easy to set the clearance for the copper tube to 1.0-1.5 mm from the clamp bar of the flaring tool.

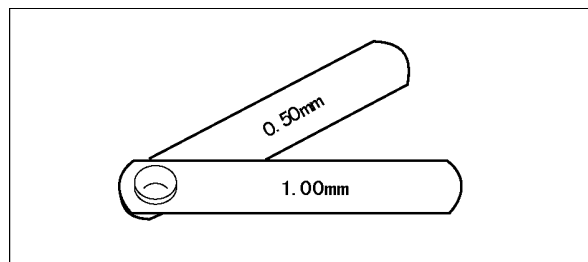

Fig. 1 Copper tube gauge for clearance adjustment

2. Flaring tool (clutch type)
  - In the R410A flaring tool, the receiving hole for the clamp bar is enlarged so the clearance from the clamp bar can be set to 0-0.5 mm, and the spring inside the tool is strengthened to increase the strength of the pipe-expanding torque. This flaring tool can also be used with R22 piping, so we recommend that you select it if you are buying a new flaring tool.

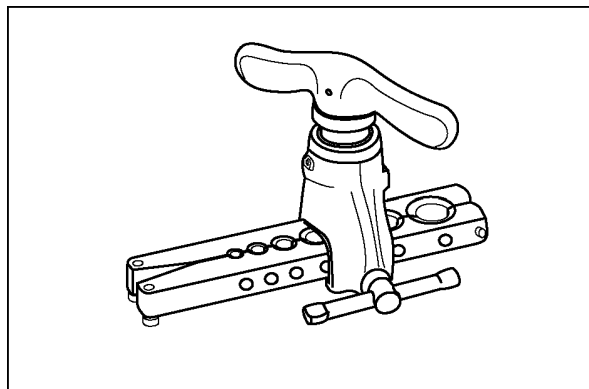

Fig. 2 Flaring tool (clutch type)

3. Torque wrenches

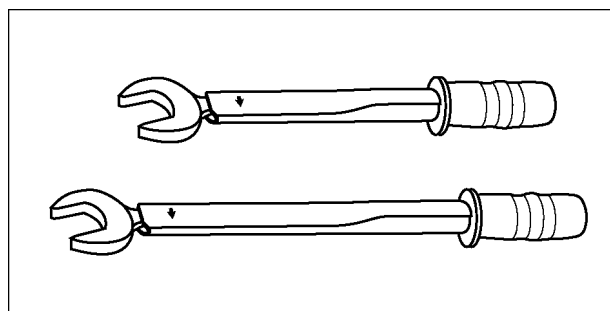

Fig. 3 Torque wrenches

Table 5

	Conventional wrenches	R410A wrenches
For 1/4 (opposite side x torque)	17mm X 18 N·m (180 kgf·cm)	17mm X 18 N·m (180 kgf·cm)
For 3/8 (opposite side x torque)	22mm X 42 N·m (420 kgf·cm)	22mm X 42 N·m (420 kgf·cm)
For 1/2 (opposite side x torque)	24mm X 55 N·m (550 kgf·cm)	26mm X 55 N·m (550 kgf·cm)

4. Manifold gauge

- Because the pressure is higher for the R410A type, the conventional type cannot be used.

Table 6 Difference between R410A and conventional high/low-pressure gauges

	Conventional gauges	R410A gauges
High-pressure gauge (red)	-76 cmHg - 35 kgf/cm <sup>3</sup>	-0.1 - 5.3 Mpa -76 cmHg - 53 kgf/cm <sup>3</sup>
Low-pressure gauge (blue)	-76 cmHg - 17 kgf/cm <sup>3</sup>	-0.1 - 3.8 Mpa -76 cmHg - 38 kgf/cm <sup>3</sup>

- The shape of the manifold ports has been changed to prevent the possibility of mistakenly charging with another type of refrigerant.

Table 7 Difference between R410A and conventional manifold port size

	Conventional gauges	R410A gauges
Port size	7/16 UNF 20 threads	1/2 UNF 20 threads

#### 5. Charging hose

- The pressure resistance of the charging hose has been raised to match the higher pressure of R410A. The hose material has also been changed to suit HFC use, and the size of the fitting has been changed to match the manifold ports.

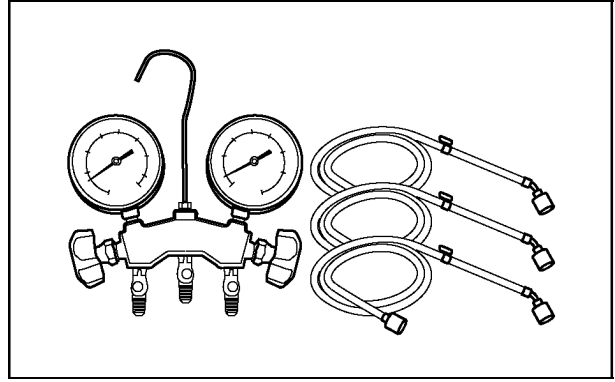

Fig. 4 Manifold gauge charging hose

Table 8 Difference between R410A and conventional charging hoses

		Conventional hoses	R410A hoses
Pressure resistance	Working pressure	3.4 MPa (35 kgf/cm <sup>3</sup> )	5.1 MPa (52 kgf/cm <sup>3</sup> )
	Bursting pressure	17.2 MPa (175 kgf/cm <sup>3</sup> )	27.4 MPa (280 kgf/cm <sup>3</sup> )
Material		NBR rubber	HNBR rubber Nylon coating inside

#### 6. Vacuum pump adaptor

- When using a vacuum pump for R410A, it is necessary to install an electromagnetic valve to prevent the vacuum pump oil from flowing back into the charging hose. The vacuum pump adaptor is installed for that purpose. If the vacuum pump oil (mineral oil) becomes mixed with R410A, it will damage the unit.

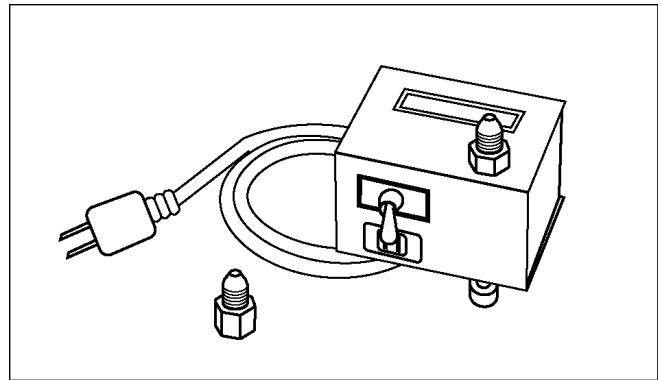

Fig. 5 Vacuum pump adaptor

#### 7. Electric gas leak detector for HFC refrigerant

- The leak detector and halide torch that were used with CFC and HCFC cannot be used with R410A (because there is no chlorine in the refrigerant).
- The present R134a leak detector can be used, but the detection sensitivity will be lower (setting the sensitivity for R134a at 1, the level for R410A will drop to 0.6).
- For detecting small amounts of gas leakage, use the electric gas leak detector for HFC refrigerant. (Detection sensitivity with R410A is about 23 g/year.)

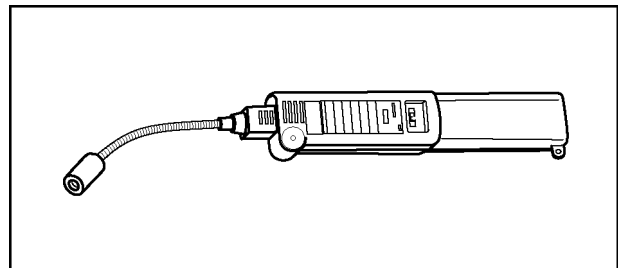

Fig. 6 Electric gas leak detector for HFC refrigerant

#### 8. Electronic scale for refrigerant charging

- Because of the high pressure and fast vaporizing speed of R410A, the refrigerant cannot be held in a liquid phase inside the charging cylinder when charging is done using the charging cylinder method, causing bubbles to form in the measurement scale glass and making it difficult to see the reading. (Naturally, the conventional R22 charging cylinder cannot be used because of the differences in the pressure resistance, scale gradation, connecting port size, etc.)
- The electronic scale has been strengthened by using a structure in which the weight detector for the refrigerant cylinder is held by four supports. It is also equipped with two connection ports, one for R22 (7/16 UNF, 20 threads) and one for R410A (1/2 UNF, 20 threads), so it can also be used for conventional refrigerant charging.
- There are two types of electronic scales, one for 10-kg cylinders and one for 20-kg cylinders. (The 10-kg cylinder is recommended.)

Refrigerant charging is done manually by opening and closing the valve.

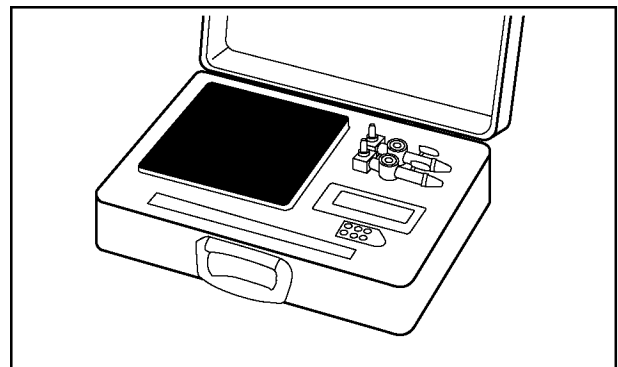

Fig. 7 Electronic scale for refrigerant charging

### 9. Refrigerant cylinders

- The R410A cylinders are labeled with the refrigerant name, and the coating color of the cylinder protector is pink, which is the color stipulated by ARI of the U.S.
- Cylinders equipped with a siphon tube are available to allow the cylinder to stand upright for liquid refrigerant charging.

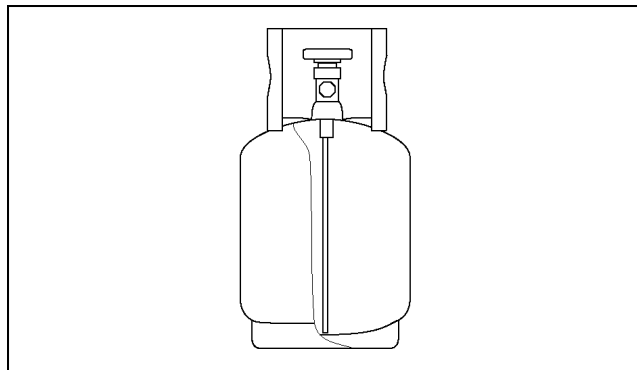

Fig. 8 Refrigerant cylinders

### 10. Charging orifice and packing for refrigerant cylinders

- The charging orifice must match the size of the charging hose fitting (1/2 UNF, 20 threads).
- The packing must also be made of an HFC-resistant material.

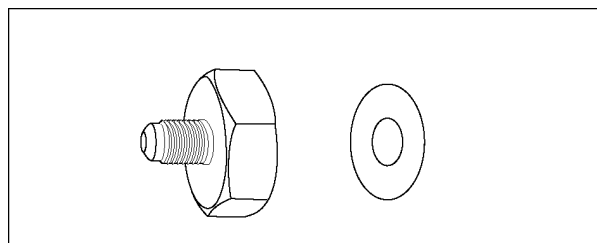

Fig. 9 Charging orifice and packing

## 10.2.3. R410A Tools Which Are Usable for R22 Models

Table 9 R410A tools which are usable for R22 models

	R410A tools	Usable for R22 models
(1)	Copper tube gauge for clearance adjustment	OK
(2)	Flaring tool (clutch type)	OK
(3)	Manifold gauge	NG
(4)	Charging hose	NG
(5)	Vacuum pump adaptor	OK
(6)	Electric gas leak detector for HFC refrigerant	NG
(7)	Electronic scale for refrigerant charging	OK
(8)	Refrigerant cylinder	NG
(9)	Charging orifice and packing for refrigerant cylinder	NG

## 10.3. REFRIGERANT PIPING WORK

### 10.3.1. Piping Materials

It is recommended that you use copper and copper alloy jointless pipes with a maximum oil adherence of 40 mg/10 m. Do not use pipes that are crushed, deformed, or discolored (especially the inside surface). If these inferior pipes are used, impurities may clog the expansion valves or capillaries.

Because the pressure of ACs using R410A is higher than those using R22, it is essential that you select materials that are appropriate for these standards.

The thickness of the copper tubing used for R410A is shown in Table 10. Please be aware that tubing with a thickness of only 0.7 mm is also available on the market, but this should never be used.

Table 10 Copper tube thickness (mm)

Soft pipe		Thickness (mm)	
Nominal diameter	Outside diameter (mm)	R410A	(Reference)R22
1/4	6.35	0.80	0.80
3/8	9.52	0.80	0.80
1/2	12.7	0.80	0.80

### 10.3.2. Processing and Connecting Piping Materials

When working with refrigerant piping, the following points must be carefully observed: no moisture or dust must be allowed to enter the piping, and there must be no refrigerant leaks.

#### 1. Procedure and precautions for flaring work

- a. Cut the pipe  
Use a pipe cutter, and cut slowly so the pipe will not be deformed.
- b. Remove burrs and clean shavings from the cut surface  
If the shape of the pipe end is poor after removing burrs, or if shavings adhere to the flared area, it may lead to refrigerant leaks. To prevent this, turn the cut surface downward and remove burrs, then clean the surface, carefully.
- c. Insert the flare nut (be sure to use the same nut that is used on the AC unit)
- d. Flaring  
Check the clamp bar and the cleanliness of the copper pipe. Be sure to use the clamp bar to do the flaring with accuracy. Use either an R410A flaring tool, or a conventional flaring tool. Flaring tools come in different sizes, so be sure to check the size before using. When using a conventional flaring tool, use the copper pipe gauge for clearance adjustment, etc., to ensure the correct A dimension (see Fig. 10)

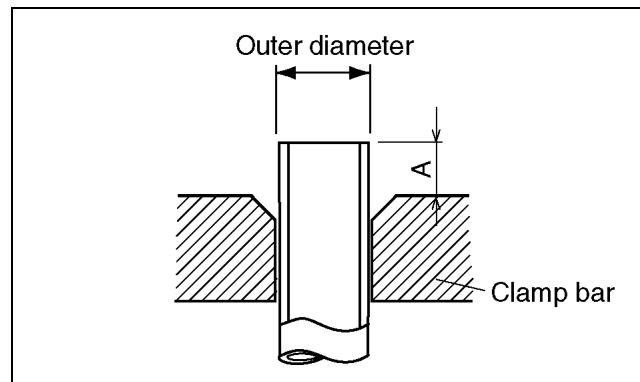

Fig. 10 Flaring dimensions

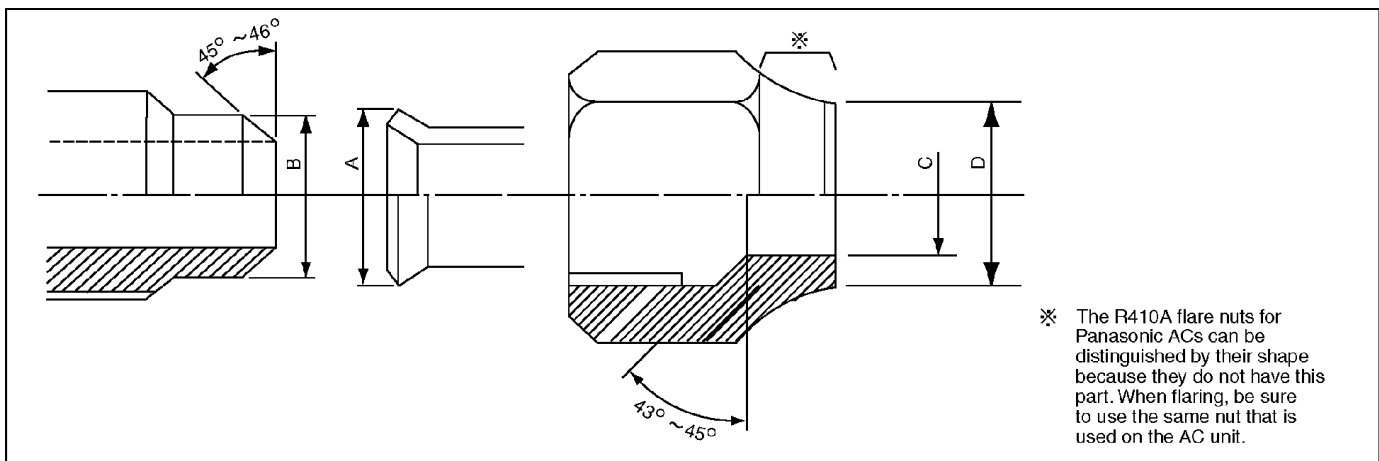

Fig. 11 Relation between the flare nut structure and flaring tool end

Table 11 R410A flaring dimensions

Nominal diameter	Outside diameter (mm)	Wall thickness (mm)	A(mm)		
			R410A flaring tool, clutch type	Conventional flaring tool	
				Clutch type	Wing-nut type
1/4	6.35	0.8	0 - 0.5	1.0 - 1.5	1.5 - 2.0
3/8	9.52	0.8	0 - 0.5	1.0 - 1.5	1.5 - 2.0
1/2	12.70	0.8	0 - 0.5	1.0 - 1.5	2.0 - 2.5

Table 12 R22 flaring dimensions

Nominal diameter	Outside diameter (mm)	Wall thickness (mm)	A(mm)		
			R410A flaring tool, clutch type	Conventional flaring tool	
				Clutch type	Wing-nut type
1/4	6.35	0.8	0 - 0.5	0.5 - 1.0	1.0 - 1.5
3/8	9.52	0.8	0 - 0.5	0.5 - 1.0	1.0 - 1.5
1/2	12.70	0.8	0 - 0.5	0.5 - 1.0	1.5 - 2.0

Table 13 R410A flare and flare nut dimensions Unit:mm

Nominal diameter	Outside diameter (mm)	Wall thickness (mm)	A +0, -0.4	B dimension	C dimension	D dimension	Flare nut width
1/4	6.35	0.8	9.1	9.2	6.5	13	17
3/8	9.52	0.8	13.2	13.5	9.7	20	22
1/2	12.70	0.8	16.6	16.0	12.9	23	26

Table 14 R22 flare and flare nut dimensions Unit:mm

Nominal diameter	Outside diameter (mm)	Wall thickness (mm)	A +0, -0.4	B dimension	C dimension	D dimension	Flare nut width
1/4	6.35	0.8	9.0	9.2	6.5	13	17
3/8	9.52	0.8	13.0	13.5	9.7	20	22
1/2	12.70	0.8	16.2	16.0	12.9	20	24

## 2. Procedure and precautions for flare connection

- Check to make sure there are no scratches, dust, etc., on the flare and union.
- Align the flared surface with the axial center of the union.
- Use a torque wrench, and tighten to the specified torque. The tightening torque for R410A is the same as the conventional torque value for R22. Be careful, because if the torque is too weak, it may lead to a gas leak. If it is too strong, it may split the flare nut or make it impossible to remove the flare nut.

Table 15 R410A tightening torque

Nominal diameter	Outside diameter (mm)	Tightening torque N·m (kgf·cm)	Torque wrench tightening torque N·m (kgf·cm)
1/4	6.35	14 - 18 (140 - 180)	18 (180)
3/8	9.52	33 - 42 (330 - 420)	42 (420)
1/2	12.70	55 (550)	55 (550)

## 10.3.3. Storing and Managing Piping Materials

### 1. Types of piping and their storage

The following is a general classification of the refrigerant pipe materials used for ACs.

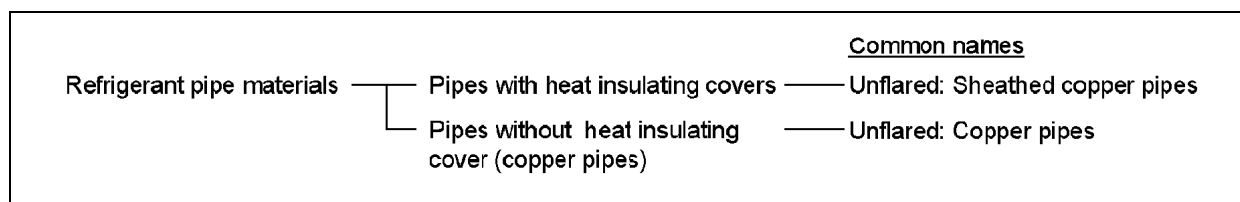

Because the gas pressure of R410A is approximately 1.6 times as high as that of R22, copper pipes with the thickness shown in Table 10, and with minimal impurities must be used. Care must also be taken during storage to ensure that pipes are not crushed, deformed, or scratched, and that no dust, moisture or other substance enters the pipe interior. When storing sheathed copper pipes or plain copper pipes, seal the openings by pinching or taping them securely.

### 2. Markings and management

#### a. Sheathed copper pipes and copper-element pipes

When using these pipes, check to make sure that they are the stipulated thickness. For flare nuts, be sure to use the same nut that is used on the AC unit.

#### b. Copper pipes

Use only copper pipes with the thickness given in table 10, and with minimal impurities. Because the surface of the pipe is exposed, you should take special care, and also take measures such as marking the pipes to make sure they are easily distinguished from other piping materials, to prevent mistaken use.

### 3. Precautions during refrigerant piping work

Take the following precautions on-site when connecting pipes. (Keep in mind that the need to control the entry of moisture and dust is even more important than in conventional piping.)

- Keep the open ends of all pipes sealed until connection with the AC equipment is complete.

- b. Take special care when doing piping work on rainy days. The entering of moisture will degrade the refrigerating machine oil, and lead to malfunctions in the equipment.
- c. Complete all pipe connections in as short a time as possible. If the pipe must be left standing for a long time after removing the seal, it must be thoroughly purged with nitrogen, or dried with a vacuum pump.

## 10.4. INSTALLATION, TRANSFERRING, SERVICING

### 10.4.1. Inspecting Gas Leaks with a Vacuum Pump for New Installations (Using New Refrigerant Piping)

1. From the viewpoint of protecting the global environment, please do not release refrigerant into the atmosphere.
  - a. Connect the projecting side (pin-pushing side) of the charging hose for the manifold gauge to the service port of the 3-way valve. (1)
  - b. Fully open the handle Lo of the manifold gauge and run the vacuum pump. (2) (If the needle of the low-pressure gauge instantly reaches vacuum, re-check step a.)
  - c. Continue the vacuum process for at least 15 minutes, then check to make sure the low-pressure gauge has reached  $-0.1$  MPa ( $-76$  cmHg). Once the vacuum process has finished, fully close the handle Lo of the manifold gauge and stop the vacuum pump operation, then remove the charging hose that is connected to the vacuum pump adaptor. (Leave the unit in that condition for 1-2 minutes, and make sure that the needle of the manifold gauge does not return.) (2) and (3)
  - d. Turn the valve stem of the 2-way valve  $90^\circ$  counter-clockwise to open it, then, after 10 seconds, close it and inspect for a gas leak (4)
  - e. Remove the charging hose from the 3-way valve service port, then open both the 2-way valve and 3-way valve. (1) (4) (Turn the valve stem in the counter-clockwise direction until it gently makes contact. Do not turn it forcefully.)
  - f. Tighten the service port cap with a torque wrench (18 N·m (1.8 kgf·m)). (5) Then tighten the 2-way valve and 3-way valve caps with a torque wrench (42 N·m (4.2 kgf·m)) or (55 N·m (5.5 kgf·m)). (6)
  - g. After attaching each of the caps, inspect for a gas leak around the cap area. (5) (6)

#### Precautions

- Be sure to read the instructions for the vacuum pump, vacuum pump adaptor and manifold gauge prior to use, and follow the instructions carefully.
- Make sure that the vacuum pump is filled with oil up to the designated line on the oil gauge.
- The gas pressure back flow prevention valve on the charging hose is generally open during use. When you are removing the charging hose from the service port, it will come off more easily if you close this valve.

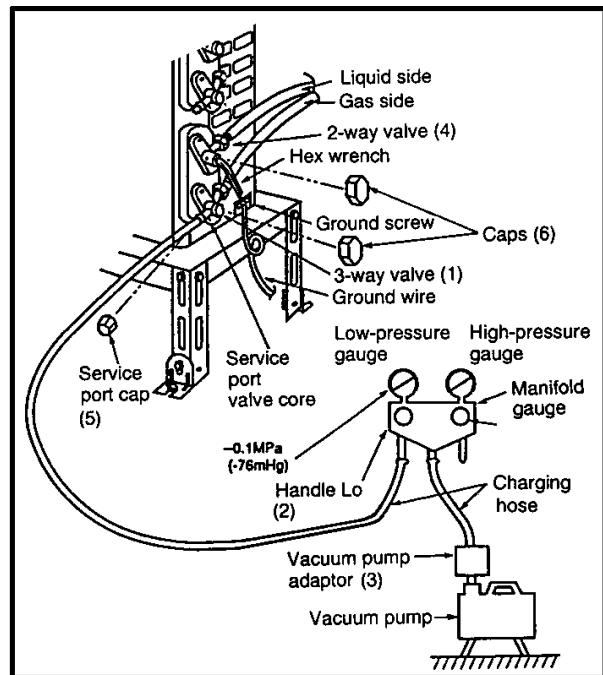

Fig. 12 Vacuum pump air purging configuration

### 10.4.2. Transferring (Using New Refrigerant Piping)

1. Removing the unit
  - a. Collecting the refrigerant into the outdoor unit by pumping down
 

The refrigerant can be collected into the outdoor unit (pumping down) by pressing the TEST RUN button, even when the temperature of the room is low.

    - Check to make sure that the valve stems of the 2-way valve and 3-way valve have been opened by turning them counter-clockwise. (Remove the valve stem caps and check to see that the valve stems are fully opened position. Always use a hex wrench (with 4-mm opposing sides) to operate the valve stems.)



- Press the TEST RUN button on the indoor unit, and allow preliminary operation for 5-6 minutes. (TEST RUN mode)
- After stopping the operation, let the unit sit for about 3 minutes, then close the 2-way valve by turning the valve stem in the clockwise direction.
- Press the TEST RUN button on the indoor unit again, and after 2-3 minutes of operation, turn the valve stem of the 3-way valve quickly in the clockwise direction to close it, then stop the operation.
- Tighten the caps of the 2-way valve and 3-way valve to the stipulated torque.
- Remove the connection pipes (liquid side and gas side).

#### b. Removing the indoor and outdoor units

- Disconnect the pipes and connecting electric cables from between the indoor and outdoor units
- Put capped flare nuts onto all of the pipe connections of the indoor and outdoor units, to make sure no dust or other foreign matter enters.
- Remove the indoor and outdoor units.

#### 2. Installing the unit

Install the unit using new refrigerant piping. Follow the instructions in section 4.1 to evacuate the pipes connecting the indoor and outdoor units, and the pipes of the indoor unit, and check for gas leaks.

### 10.4.3. AC Units Replacement (Using Existing Refrigerant Piping)

When replacing an R410A AC unit with another R410A AC unit, you should re-flare the refrigerant piping. Even though the replacement AC unit uses the R410A, problems occur when, for example, either the AC unit maker or the refrigerating machine oil is different.

When replacing an R22 AC unit with an R410A AC unit, the following checks and cleaning procedures are necessary but are difficult to do because of the chemical characteristics of the refrigerating machine oil (as described in items c) and d) of section 10.1.1.(2)). In this case, you should use new refrigerant piping rather than the existing piping.

#### 1. Piping check

Because of the different pressure characteristics of R22 and R410A, the design pressure for the equipment is 1.6 times different. The wall thickness of the piping must comply with that shown in Table 10, but this is not easy to check. Also, even if the thickness is correct, there may be flattened or bent portions midway through the piping due to sharp curves. Buried sections of the piping also cannot be checked.

#### 2. Pipe cleaning

A large quantity of refrigerating machine oil (mineral oil) adheres to existing pipes due to the refrigeration cycle circulation. If the pipes are used just as they are for the R410A cycle, the capacity will be lowered due to the incompatibility of this oil with the R410A, or irregularities may occur in the refrigeration cycle. For this reason, the piping must be thoroughly cleaned, but this is difficult with the present technology.

### 10.4.4. Refrigerant Compatibility (Using R410A Refrigerant in R22 ACs and Vice Versa)

Do not operate an existing R22 AC with the new R410A refrigerant. Doing so would result in improper functioning of the equipment or malfunction, and might lead to a major accident such as an explosion in the refrigeration cycle. Similarly, do not operate an R410A AC with R22 refrigerant. The chemical reaction between the refrigerating machine oil used in R410A ACs and the chlorine that is contained in R22 would cause the refrigerating machine oil to degrade and lead to malfunction.

### 10.4.5. Recharging Refrigerant During Servicing

When recharging is necessary, insert the specified amount of new refrigerant in accordance with the following procedure.

1. Connect the charging hose to the service port of the outdoor unit.
2. Connect the charging hose to the vacuum pump adaptor. At this time, fully open the 2-way valve and 3-way valve.
3. Fully open the handle Lo of the manifold gauge, turn on the power of the vacuum pump and continue the vacuum process for at least one hour.
4. Confirm that the low pressure gauge shows a reading of -0.1 Mpa (-76 cmHg), then fully close the handle Lo, and turn off the vacuum pump. Wait for 1-2 minutes, then check to make sure that the needle of the Low pressure gauge has not returned. See Fig.13 for the remaining steps of this procedure.
5. Set the refrigerant cylinder onto the electronic scale, then connect the hose to the cylinder and to the connection port for the electronic scale. (1)(2)

#### Precaution:

Be sure to set up the cylinder for liquid charging. If you use a cylinder equipped with a siphon tube, you can charge the liquid without having to turn the cylinder around

6. Remove the charging hose of the manifold gauge from the vacuum pump adaptor, and connect it to the connection port of the electronic scale. (2)(3)

7. Open the valve of the refrigerant cylinder, then open the charging valve slightly and close it. Next, press the check valve of the manifold gauge and purge the air. (2)(4) (Watch the liquid refrigerant closely at this point.)
8. After adjusting the electronic scale to zero, open the charging valve, then open the valve Lo of the manifold gauge and charge with the liquid refrigerant. (2)(5) (Be sure to read the operating instructions for the electronic scale.)
9. If you cannot charge the stipulated amount, operate the unit in the cooling mode while charging a little of the liquid at a time (about 150 g/time as a guideline). If the charging amount is insufficient from one operation, wait about one minute, then use the same procedure to do the liquid charging again.

**Precaution:**

Never use the gas side to allow a larger amount of liquid refrigerant to be charged while operating the unit.

10. Close the charging valve, and after charging the liquid refrigerant inside the charging hose, fully close the valve Lo of the manifold gauge, and stop the operation of the unit. (2)(5)
11. Quickly remove the charging hose from the service port. (6) If you stop midway through, the refrigerant that is in the cycle will be discharged.
12. After putting on the caps for the service port and operating valve, inspect around the caps for a gas leak. (6)(7)

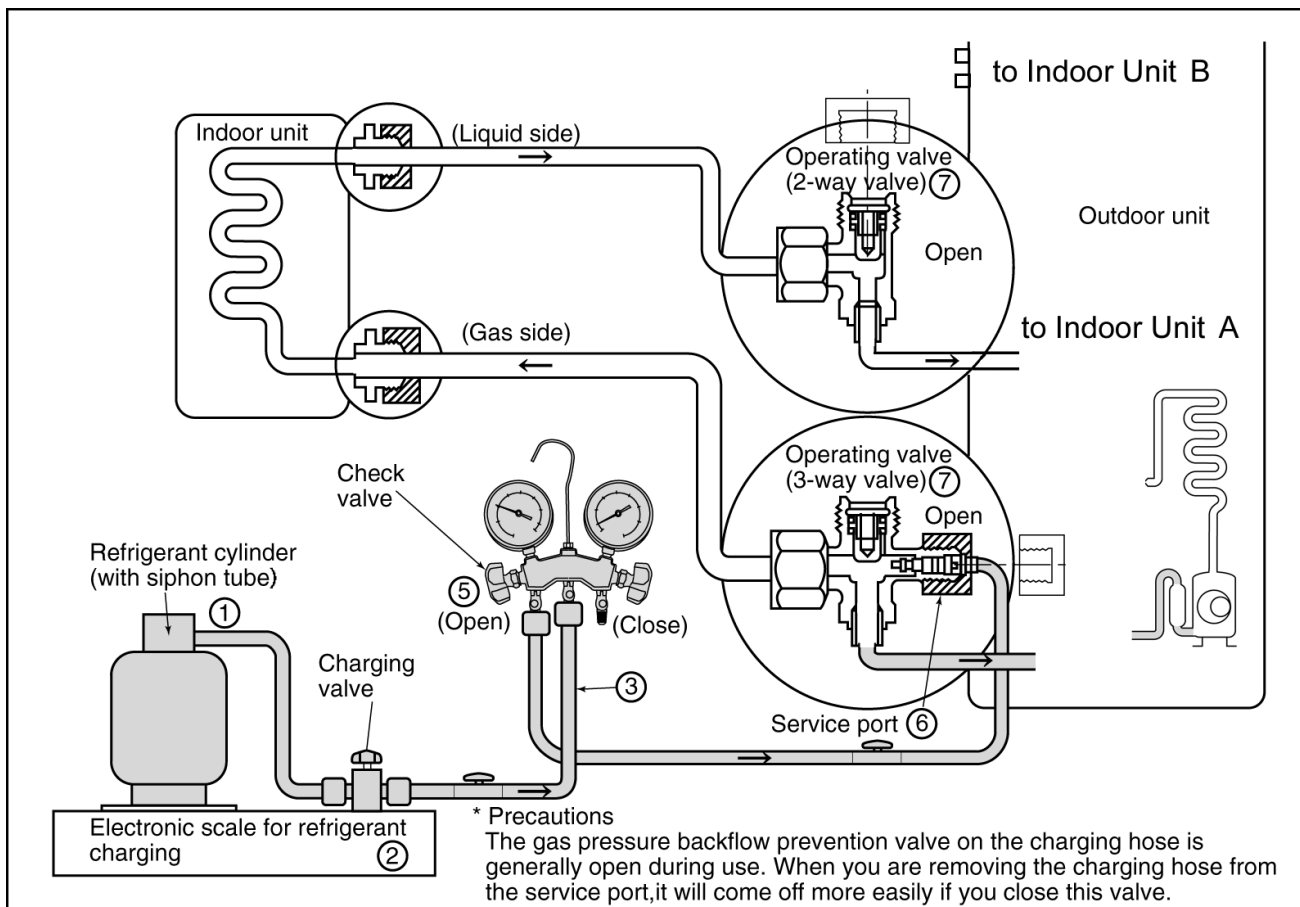

Fig. 13 Re-charging refrigerant

### 10.4.6. Brazing

As brazing requires sophisticated techniques and experiences, it must be performed by a qualified person.

In order to prevent the oxide film from occurring in the pipe interior during brazing, it is effective to proceed with brazing while letting dry nitrogen gas ( $N_2$ ) flow.

**<Brazing Method for Preventing Oxidation>**

1. Attach a reducing valve to the nitrogen gas cylinder.
2. Attach a reducing valve to the nitrogen gas cylinder.
3. Apply a seal onto the clearance between the piping and inserted pipe for the nitrogen gas in order to prevent the nitrogen gas from flowing backward.
4. When the nitrogen gas is flowing, be sure to keep the piping end open.
5. Adjust the flow rate of nitrogen gas so that it is lower than  $0.05 \text{ m}^3/\text{h}$ , or  $0.02 \text{ MPa}$  ( $0.2 \text{ kgf/cm}^2$ ) by means of the reducing valve.

6. After taking the steps above, keep the nitrogen gas flowing until the piping cools down to a certain extent (i.e. temperature at which pipes are touchable with finger).
7. Completely remove the flux after brazing.

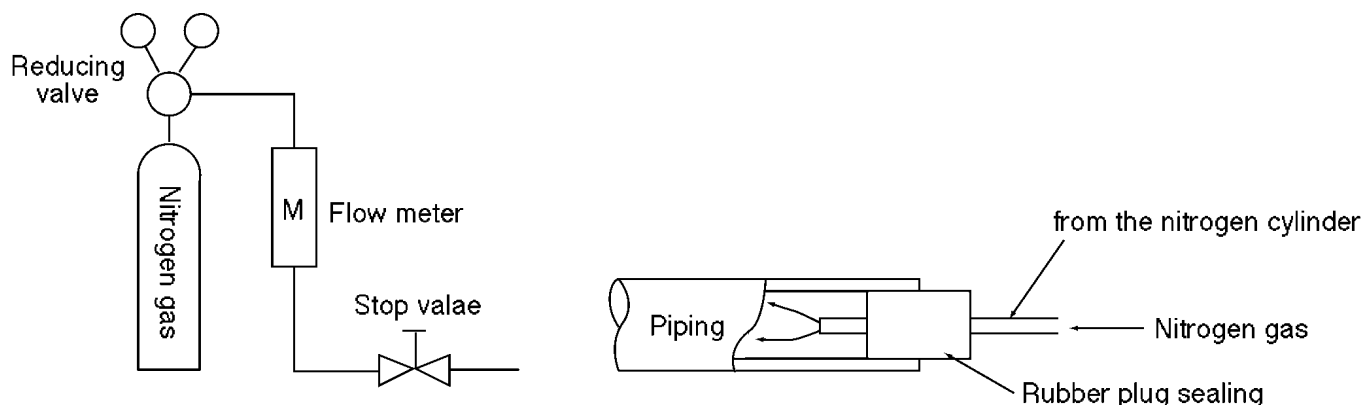

Fig. 14 Prevention of Oxidation during Brazing

#### \* Cautions during brazing

##### 1. General Cautions

- a. The brazing strength should be high as required.
- b. After operation, airtightness should be kept under pressurized condition.
- c. During brazing do not allow component materials to become damaged due to overheating.
- d. The refrigerant pipe work should not become blocked with scale or flux.
- e. The brazed part should not restrict the flow in the refrigerant circuit.
- f. No corrosion should occur from the brazed part.

##### 2. Prevention of Overheating

Due to heating, the interior and exterior surfaces of treated metal may oxidize. Especially, when the interior of the refrigerant circuit oxidizes due to overheating, scale occurs and stays in the circuit as dust, thus exerting a fatally adverse effect. So, make brazing at adequate brazing temperature and with a minimum of heating area.

##### 3. Overheating Protection

In order to prevent components near the brazed part from overheating damage or quality deterioration due to flame or heat, take adequate steps for protection such as (1) by shielding with a metal plate, (2) by using a wet cloth, and (3) by means of heat absorbent.

##### 4. Movement during Brazing

Eliminate all vibration during brazing to protect brazed joints from cracking and breakage.

##### 5. Oxidation Preventative







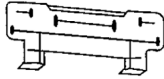

In order to improve the brazing efficiency, various types of antioxidant are available on the market. However, the constituents of these are widely varied, and some are anticipated to corrode the piping materials, or adversely affect HFC refrigerant, lubricating oil, etc. Exercise care when using an oxidation preventative.

### 10.4.7. Servicing Tips

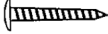
**The drier must also be replaced whenever replacing the refrigerant cycle parts. Replace the refrigerant cycle parts first before replacing the drier. The drier is supplied in a vacuum pack. Perform brazing immediately after opening the vacuum pack, and then start the vacuum within two hours. In addition, the drier also needs to be replaced when the refrigerant has leaked completely.**

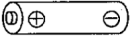
# 11 Installation Information

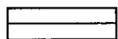
## 11.1. ATTACHED ACCESSORIES

No.	Accessory part	Qty.	No.	Accessory part	Qty.
1	Installation plate 	1	6	Drain elbow 	1
2	Installation plate fixing screw 	6		This part is packed with the outdoor unit.	
3	Remote control 	1	7	Band 	2
4	Battery 	2 × 2	8	Vinyl tape 	3
	This part is packed with the outdoor unit.		9	Vinyl tape 	1
5	Air purifying filter 	2			

## 11.2. SELECT THE BEST LOCATION

### 11.2.1. INDOOR UNIT

- There should not be any heat source or steam near the unit.
- There should not be any obstacles blocking the air circulation.
- A place where air circulation in the room is good.
- A place where drainage can be easily done.
- A place where noise prevention is taken into consideration.
- Do not install the unit near the door way.
- Ensure the spaces indicated by arrows from the wall, ceiling, fence or other obstacles.
- Indoor unit of this room air conditioner shall be installed on the wall in a height of at least 2.3m.

### 11.2.2. OUTDOOR UNIT

- If an awning is built over the unit to prevent direct sunlight or rain, be careful that heat radiation from the condenser is not obstructed.
- Ensure that no animals or plants can be affected by the hot air discharged.
- Keep the spaces indicated by arrows from wall, ceiling, fence or other obstacles.
- Do not place any obstacles which may cause a short circuit of the discharged air.
- If piping length is over the common length, additional refrigerant should be added as shown in the table.

### 11.2.3. PIPING LENGTH

Piping size		Common Length (m)	Min. total Length (m)	Max. total Length (m)	Max. Elevation (m)	Additional gas charge amount (g/m)
Gas	Liquid					
3/8"	1/4"	15	6 (3m / Indoor unit)	30 *1	10	15 *2

**Note:**

\*1. It is possible to extend the piping length of one unit up to 25 meters. However, the total piping length must not exceed 30 meters.

\*2. If the piping length exceeds 15 meters, refrigerant of 15g per meter must be added.

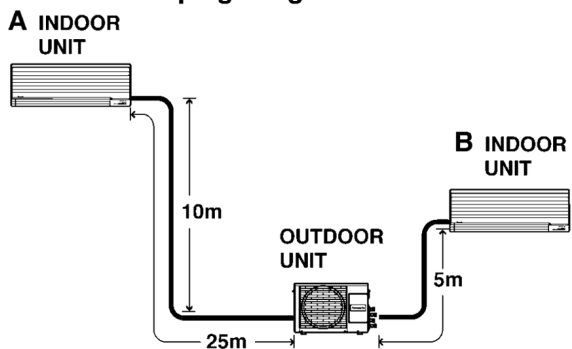
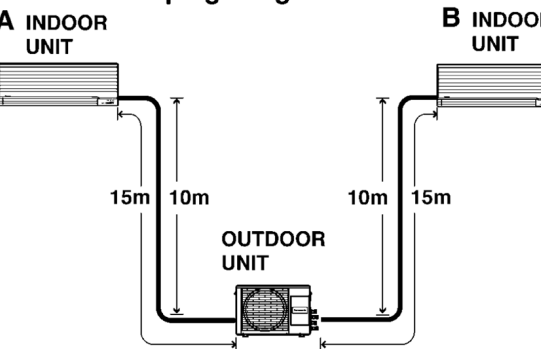
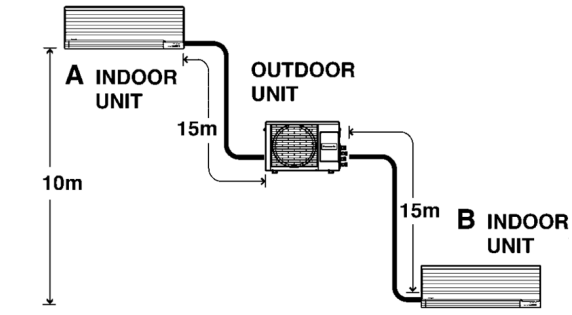
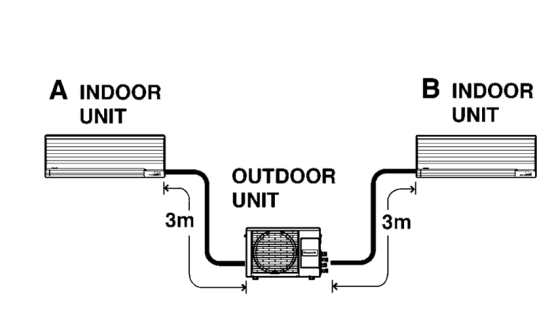
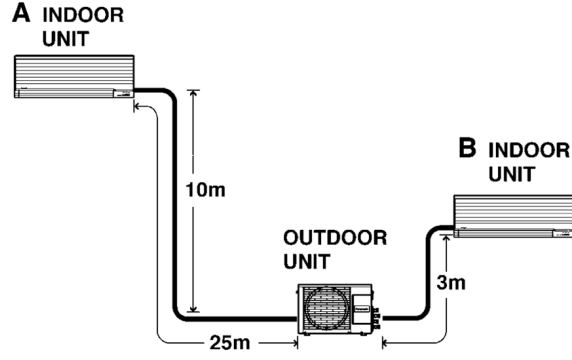
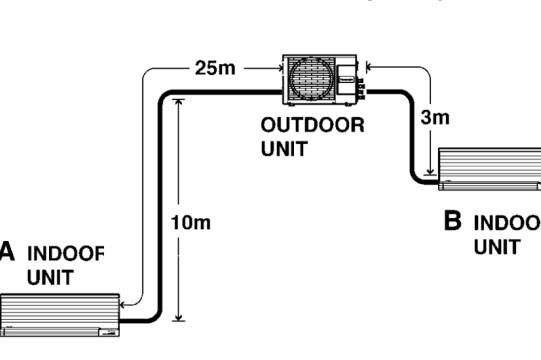
<p>• <b>Maximum Piping Length</b></p>  <p>• <b>Additional Gas Charge</b> ( 30m - 15m ) X 15g = 225g</p>	<p>• <b>Maximum Piping Length</b></p>  <p>• <b>Additional Gas Charge</b> ( 30m - 15m ) X 15g = 225g</p>
<p>• <b>Maximum Piping Length</b></p>  <p>• <b>Additional Gas Charge</b> ( 30m - 15m ) X 15g = 225g</p>	<p>• <b>Minimum Piping Length</b></p> 
<p>• <b>Maximum &amp; Minimum Piping Length</b></p>  <p>• <b>Additional Gas Charge</b> ( 28m - 15m ) X 15g = 195g</p>	<p>• <b>Maximum &amp; Minimum Piping Length</b></p>  <p>• <b>Additional Gas Charge</b> ( 28m - 15m ) X 15g = 195g</p>

### 11.3. INDOOR/OUTDOOR UNIT INSTALLATION DIAGRAM

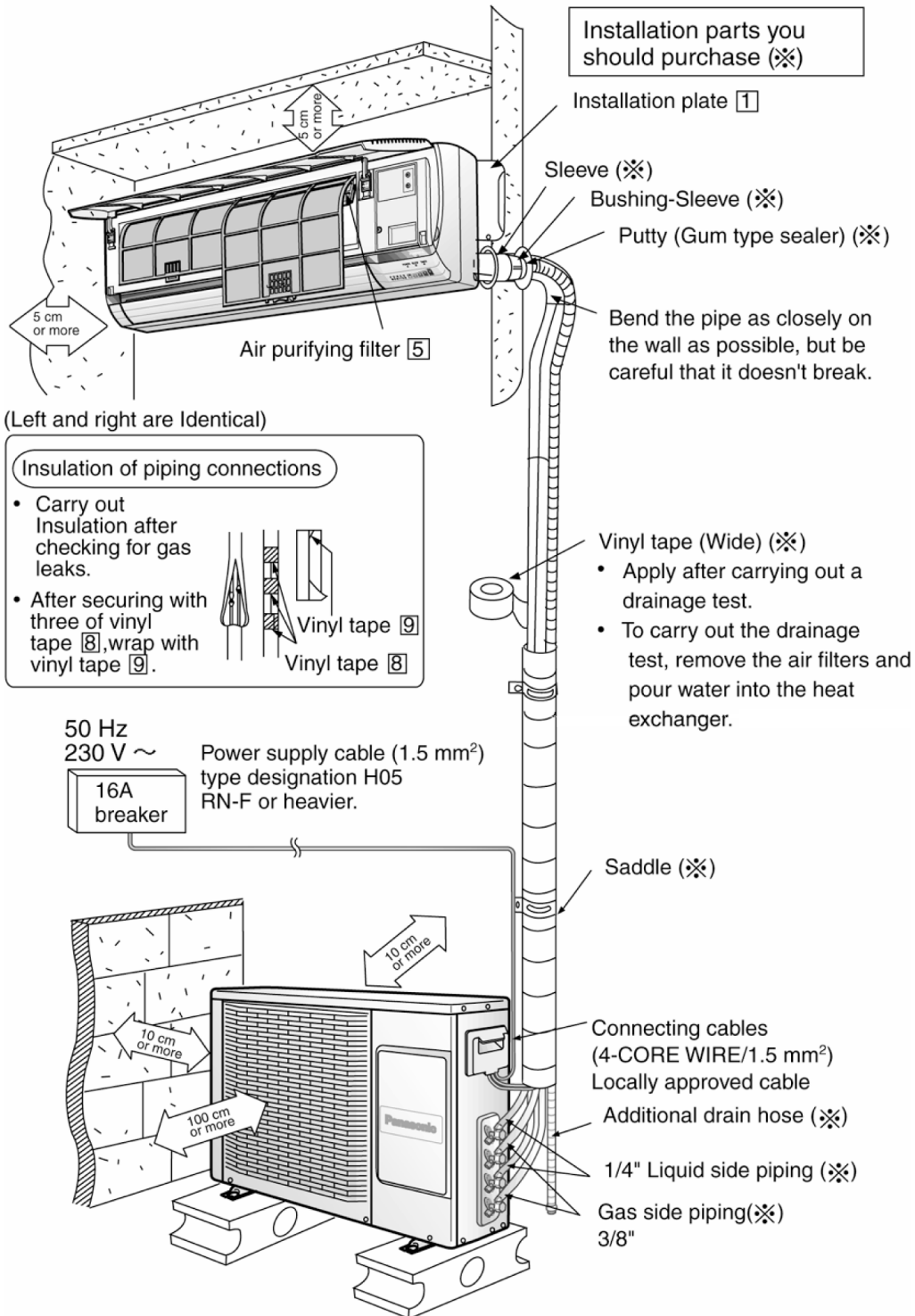
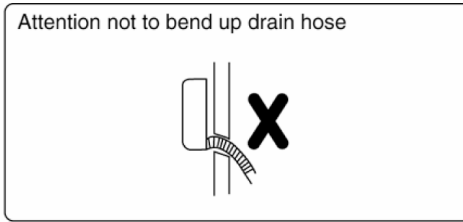
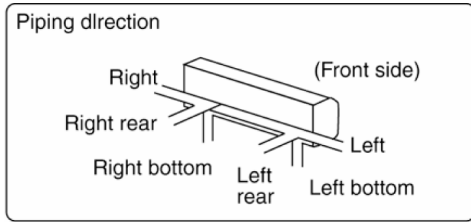

• This illustration is for explanation purposes only.  
The indoor unit may actually face a different way.

## 11.4. CONNECTION PIPES FOR AIR CONDITIONER UNITS WITH R410A

· It is necessary to use seamless copper pipes which are made of either copper or copper alloy and it is desirable that the amount of residual oil is less than 40mg / 10m. Do not use copper pipes having a collapsed, deformed or discolored portion (especially on the interior surface). Otherwise, the expansion valve or capillary tube may become blocked with contaminants.

As an air conditioner using R410A incurs pressure higher than when using R22, it is necessary to choose adequate materials. Thicknesses of copper pipes used with R410A are as shown in Table. Never use copper pipes thinner than 0.8mm.

Table : Thicknesses of Annealed Copper Pipes

Nominal diameter	Outer diameter (mm)	Thickness (mm)
		R410A
1/4	6.35	0.80
3/8	9.52	0.80

## 11.5. NOTE

1. "Switching events of the automatic thermostat control of this equipment may temporarily generate strong electromagnetic disturbances that could effect other apparatus in the same power supply system. Don't connect other electric appliances to the same supply lines."
2. "this equipment does not comply with the relevant technical standards for the limitation of harmonic currents emissions and may cause adverse effects to other equipment. Before connecting this equipment to the power supply system, please report to your supply authority and obtain their consent. Do not connect other electric appliances to the same supply lines."

# 12 Servicing Information

## 12.1. TROUBLESHOOTING

### 12.1.1. RATED FREQUENCY OPERATION

During troubleshooting and servicing, rated compressor operating frequency must be obtained in order to check the specification and technical data. Below are the methods used to obtain rated compressor operating specification.

#### 1. Cooling

- Press the Test Run button on the indoor unit. The air conditioner starts operation at Cooling rated frequency.

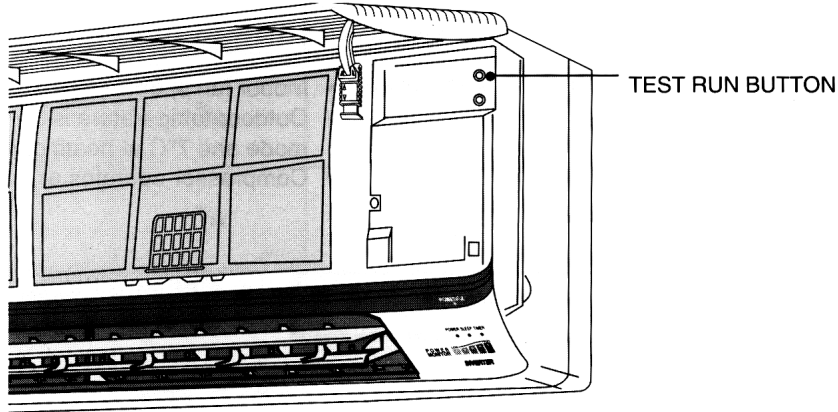

#### 2. Heating

Keep pressing the Test Run button, outdoor power supply turned off and on, then release the Test Run button. The air conditioner starts operation at Heating rated frequency.

### 12.1.2. TROUBLESHOOTING AIR CONDITIONER

#### Refrigeration cycle system

In order to diagnose malfunctions, make sure that there are no electrical problems before inspecting the refrigeration cycle. Such problems include insufficient insulation, problem with the power source, malfunction of a compressor or a fan.

The normal outlet air temperature and pressure of the refrigeration cycle depends on various conditions; the standard values for them are shown in the following table.

	Gas pressure MPa (kg/cm <sup>2</sup> G)	Outlet air temperature (°C)
Cooling Mode	0.9~1.2 (9~12)	12~16
Heating Mode	2.3~2.9 (23~29)	36~48

Normal Pressure and Outlet Air Temperature (Standard)

#### Condition:

- Indoor fan speed; High
- Outdoor temperature is 35 °C at cooling mode and 7 °C at heating mode.
- Compressor operates at rated frequency.



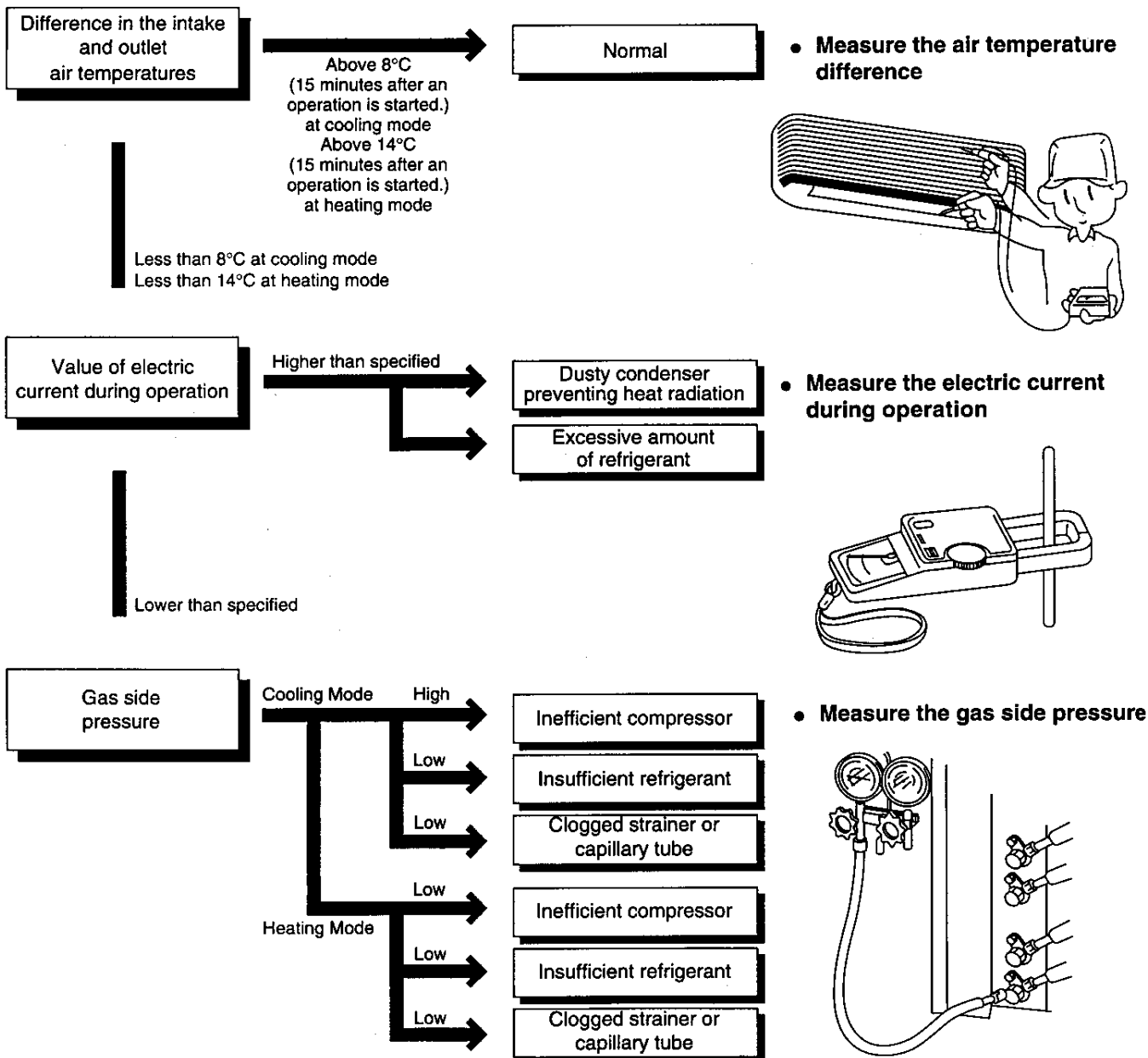

**Relationship between the condition of the air conditioner and pressure and electric current**

Condition of the air conditioner	Cooling Mode			Heating Mode		
	Low Pressure	High Pressure	Electric current during operation	Low Pressure	High Pressure	Electric current during operation
Insufficient refrigerant (gas leakage)	↘	↘	↘	↘	↘	↘
Clogged capillary tube or Strainer	↘	↘	↘	↗	↗	↗
Short circuit in the indoor unit	↘	↘	↘	↗	↗	↗
Heat radiation deficiency of the outdoor unit	↗	↗	↗	↘	↘	↘
Inefficient compression	↗	↗	↗	↘	↘	↘

• Carry out the measurements of pressure, electric current, and temperature fifteen minutes after an operation is stated.

## 12.2. SELF DIAGNOSIS DISPLAY

The diagnostic display can be seen on the receiver of the Front Grille.

- When an abnormality occurs, the unit automatically stops, and the TIMER LED blinks to indicate a malfunction. At the same time, the type of abnormality will be indicated on the receiver as shown in the diagram below. Providing this information reduces the time spent in diagnosing procedures.

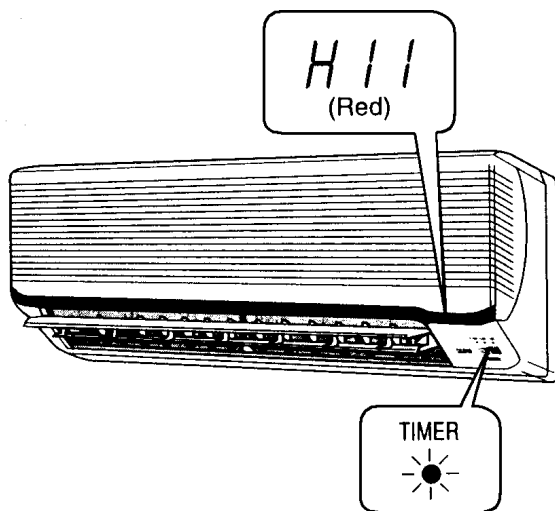

- The diagnostic display vanishes when the power is turned off.
- When power is re-supplied and the Diagnostic Terminal on the Remote Control is shorted, the type of the previous abnormality and the protection control works will be displayed on the receiver for approximately 10 seconds.

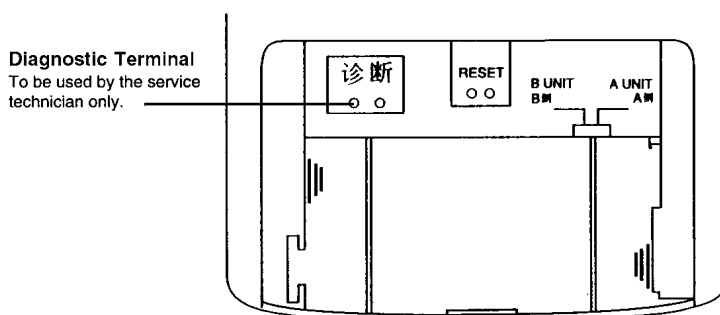

- By starting cooling operation using TEST RUN button and short the Diagnostic Terminal at the remote control, the previous abnormalities are deleted.
- Depending on the type of abnormality, you may be able to override the abnormality and use temporary operation (for abnormalities indicated by "●" mark in the table below).

Use the remote control to select cooling or heating operation mode and press OFF/ON button. At this moment, four short beeps "bip.bip.bip.bip" will sound and TIMER LED will blink.

Diagnosis display	Abnormality/Protection control	Abnormality Judgement	Temporary operation	Primary location to verify
H11	Indoor/outdoor abnormal communication	1 min after starting operation	-	<ul style="list-style-type: none"> <li>Internal/external cable connections</li> <li>Indoor/Outdoor PCB</li> </ul>
H12	Indoor unmatched capacity abnormality		-	<ul style="list-style-type: none"> <li>Indoor Unit</li> </ul>
H14	Indoor intake air temperature sensor abnormality		-	<ul style="list-style-type: none"> <li>Intake air temperature sensor (defective or disconnected)</li> </ul>
H15	Outdoor compressor temperature sensor abnormality		-	<ul style="list-style-type: none"> <li>Compressor temperature sensor (defective or disconnected)</li> </ul>
H16	Outdoor Current Transformer open circuit		-	<ul style="list-style-type: none"> <li>Outdoor PCB</li> <li>Power transistor module</li> </ul>
H17	Outdoor suction pipe temperature sensor abnormality		-	<ul style="list-style-type: none"> <li>Outdoor suction pipe temperature sensor (defective or disconnected)</li> </ul>
H19	Indoor fan motor mechanism lock		-	<ul style="list-style-type: none"> <li>Indoor PCB</li> <li>Fan motor</li> </ul>

Diagnosis display	Abnormality/Protection control	Abnormality Judgement	Temporary operation	Primary location to verify
H23	Indoor heat exchanger temperature sensor 1 abnormality		● (Cooling only)	• Heat exchanger temperature sensor (defective or disconnected)
H24	Indoor heat exchanger temperature sensor 2 abnormality		●	• Indoor heat exchanger temperature sensor 2 (defective or disconnected)
H27	Outdoor air temperature sensor abnormality		●	• Outdoor temperature sensor (defective or disconnected)
H28	Outdoor heat exchanger temperature sensor 1 abnormality		●	• Outdoor heat exchanger temperature sensor (defective or disconnected)
H30	Outdoor discharge pipe temperature sensor abnormality		●	• Outdoor discharge pipe temperature sensor (defective or disconnected)
H32	Outdoor heat exchanger temperature sensor 2 abnormality		●	• Outdoor heat exchanger temperature sensor 2 abnormality (defective or disconnected)
H98	Indoor high pressure protection		-	• Air filter dirty • Air circulation short circuit
H99	Indoor heat exchanger anti-freezing protection		-	• Insufficient refrigerant • Air filter dirty
F11	Cooling/Heating cycle changeover abnormality	4 times occurrence within 40 minutes	-	• 4-way valve • V-coil
F91	Refrigeration cycle abnormality	2 times occurrence within 30 minutes	-	• No refrigerant (3-way valve is closed)
F93	Compressor motor rotation abnormality	2 times occurrence within 30 minutes	-	• Compressor • Outdoor P.C.Board
F95	Over heating protections	3 times occurrence within 30 minutes	-	• Pipe sensor
F96	Outdoor power transistor module overheating protection	4 times occurrence within 30 minutes	-	• Excess refrigerant • Improper heat radiation • Power transistor
F97	Outdoor compressor overheating protection	4 times occurrence within 20 minutes	-	• Insufficient refrigerant • Compressor
F98	Total running current protection	3 times occurrence within 30 minutes	-	• Excess refrigerant • Improper heat radiation
F99	Outdoor Direct Current (DC) peak detection	2 times occurrence continuously	-	• Outdoor PCB • Power transistor • Compressor

### 1. Current Transformer Defective

When the Current Transformer (CT) is an open circuit, total running current is less than 1.51 A and the indicated frequency is Rated frequency. After 3 minutes of operation, the abnormality signal is sent from outdoor to indoor and [H16] is displayed.

### 2. 4 Way Valve Defective

#### a. Heating Operation (except Deice)

After 4 minutes of operation, the indoor heat exchanger temperature is lower than 5°C. The operation stops and restarts after 3 minutes. If this phenomenon occurs for 4 times within 40 minutes, [F11] is displayed.

#### b. Cooling Operation

After 4 minutes of operation, indoor heat exchanger temperature is higher than 45°C. The operation stops and restarts after 3 minutes. If this phenomenon occurs for 4 times within 40 minutes, [F11] is displayed.

The abnormality judgement is not carried out, in the following conditions:

- deice operation
- 2 minutes after deice operation
- hot start
- 2 minutes after hot start
- 3 minutes after heating and cooling/soft dry mode changeover

## 12.3. REMOTE CONTROL

### 12.3.1. Remote Control reset

When the batteries are inserted for the first time, or the batteries are replaced, all the indications will blink and the remote control might not work.

If this happens, remove the back cover of the remote control and you will find a resetting terminal, and by shorting it with a minus screwdriver, it will return to normal.

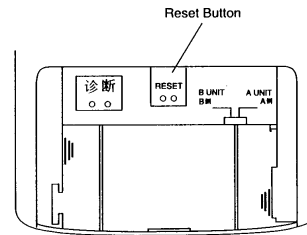

### 12.3.2. Changing the wireless remote control transmission code

#### REMOTE CONTROL NO. SWITCH

- When installing two air conditioners in one room, each air conditioner can be synchronized to the remote controller.
- In order to operate separately, open the rear cover of one of the remote controller and set the switch to "B".

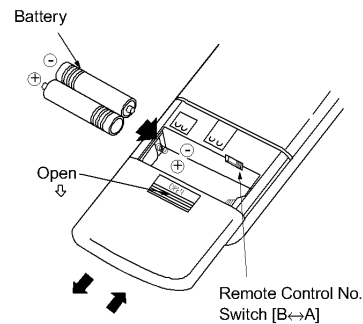

#### SETTING THE AIR CONDITIONER UNIT TO B

1. Press the AUTO button while pressing the TEST run button. "A" will now appear on the display.

While pressing the TEST run button:

Press the AUTO button.

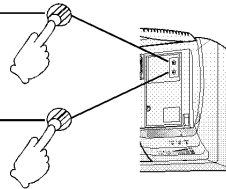

2. The display changes to "B" when the AUTO button is pressed.
3. Use the remote controller, which has been set to B, to check the operation.

Display on the air conditioner unit

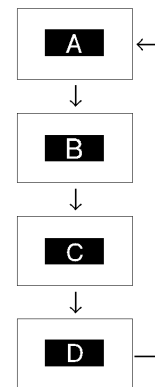

By adding a jumper wire to the remote control side, it is possible to select 4 transmission codes including one at time of delivery condition (1).

	Remote control		Indoor Setting Code	Note
	Switch SW B ↔ A	J-1		
1	A	---	A	At product delivery
2	B	---	B	
3	A	Jumper wire	C	
4	B	Jumper wire	D	

### 12.3.3. Remote Control Batteries

The batteries can be used for approximately one year. When the batteries become weak, the display of the remote control may fade or disappear. Replace the batteries immediately.

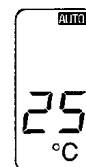

## 12.4. DISASSEMBLY OF PARTS

### 12.4.1. Indoor Control Board removal Procedure

1. Remove the Front Grille

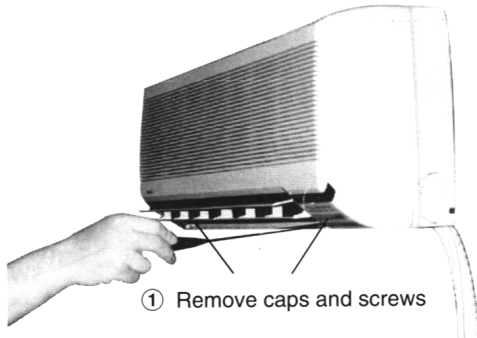

Fig1

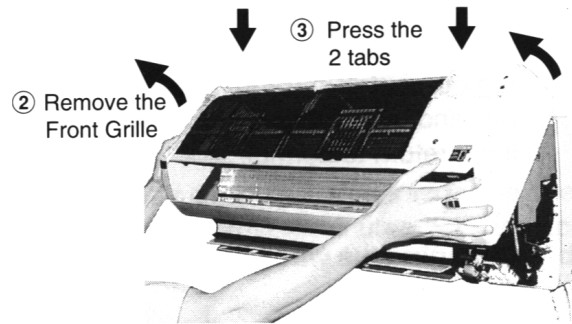

Fig2

2. Remove the Indoor Control Board.

④ Disconnect all connectors

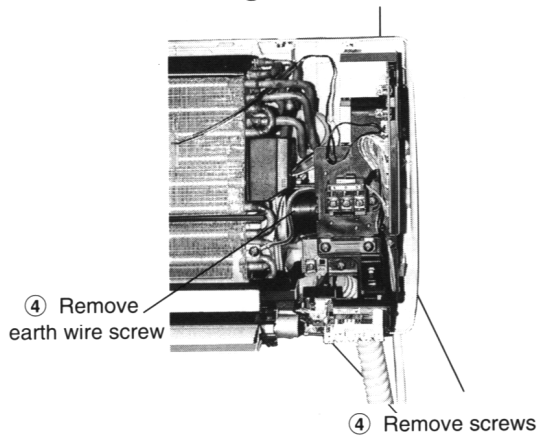

Fig3

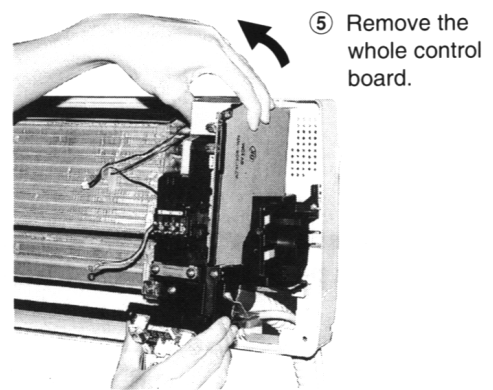

Fig4

Note : Remove the indoor and outdoor connecting wires from terminal **1**, **2**, **3** and **⊥**.

### 12.4.2. Removal of Electronic Controller Procedure

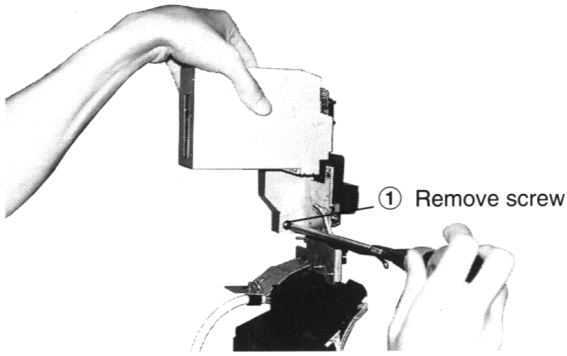

Fig5

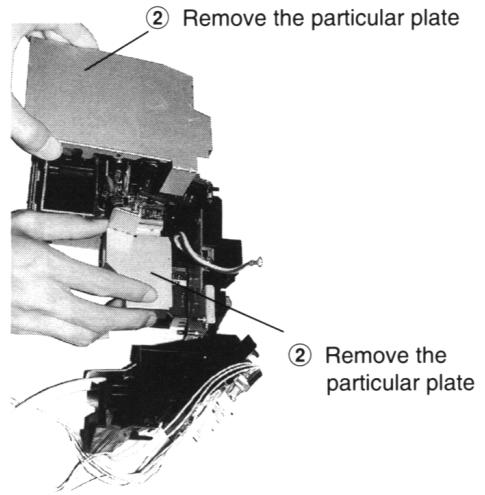

Fig6

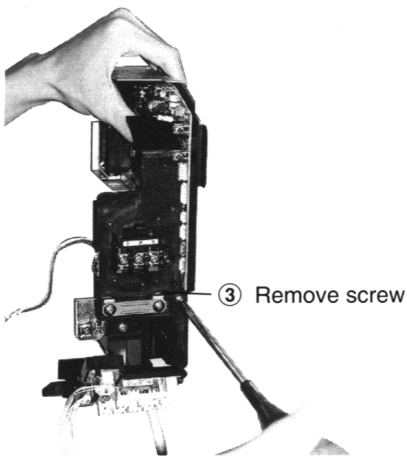

Fig7

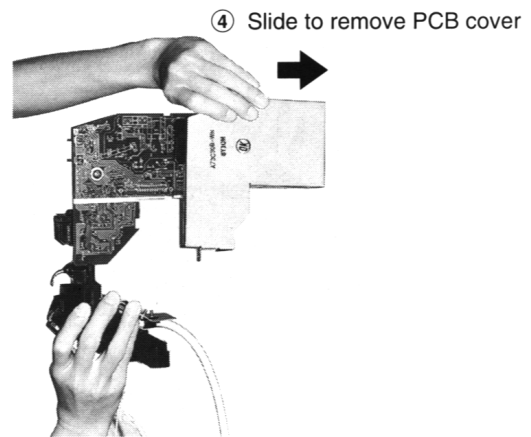

Fig8

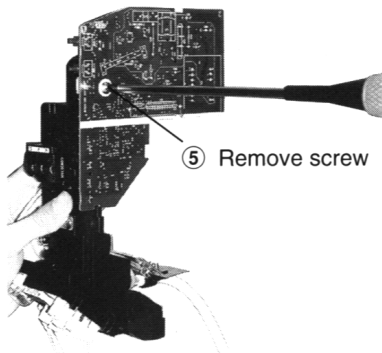

Fig9

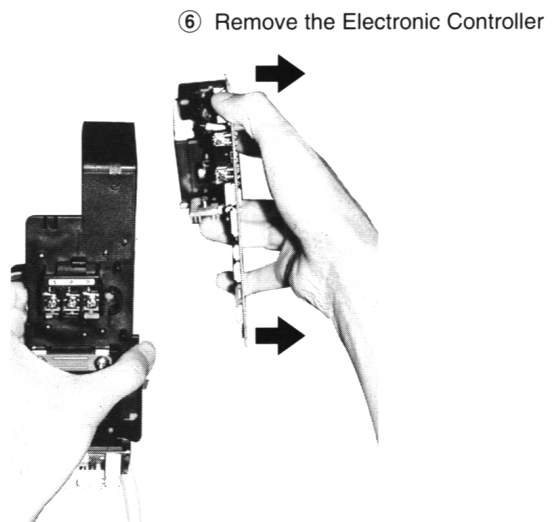

Fig10

### 12.4.3. Indoor Fan Motor Removal Procedure

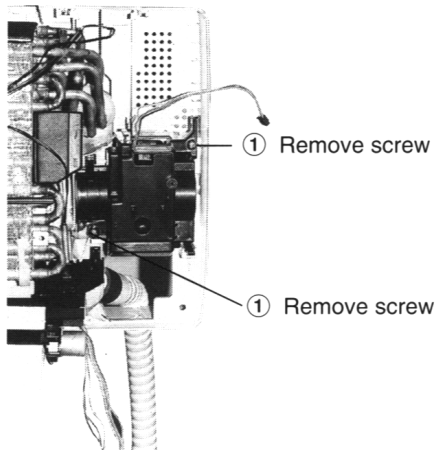

Fig11

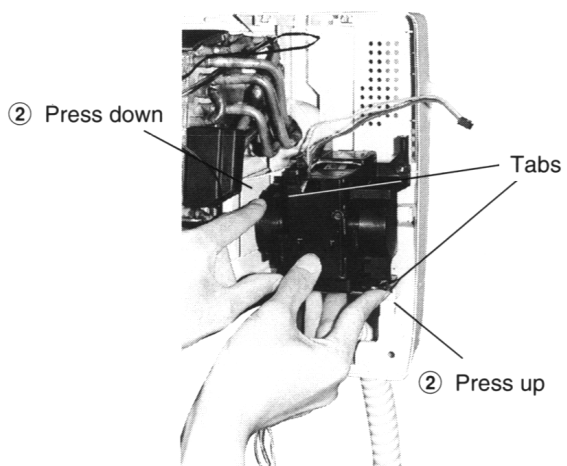

Fig12

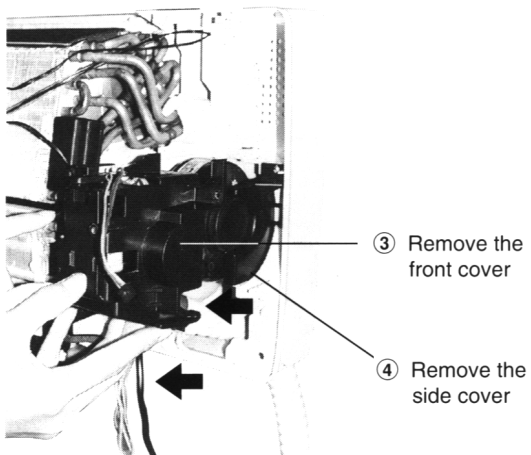
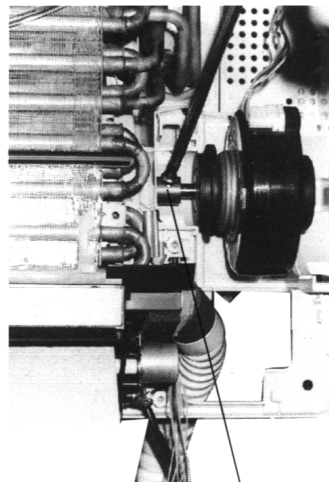

Fig13



⑤ Remove the Cross Flow Fan Screw

Fig14

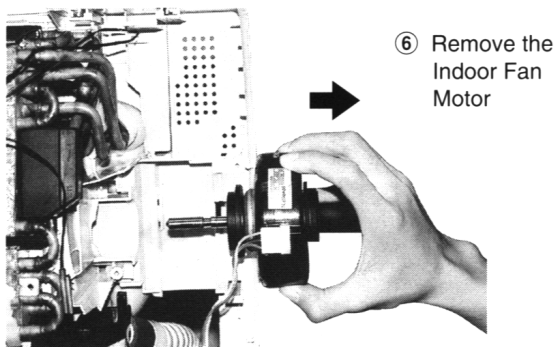
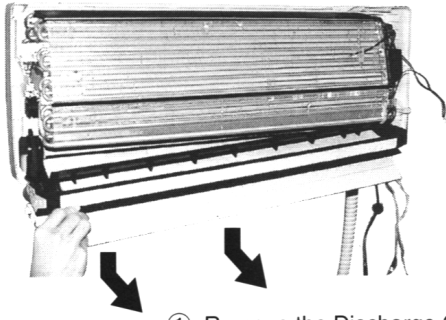

Fig15

### 12.4.4. Cross Flow Fan Removal Procedure

1. Remove Discharge Grille



① Remove the Discharge Grille  
Fig16

2. Remove Cross Flow Fan

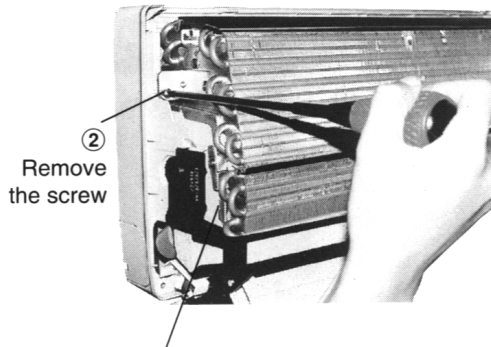

② Remove the screw

③ Release the slot of indoor heat exchanger from the chassis

Fig17

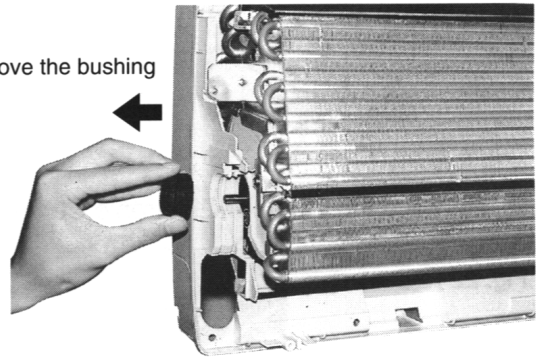

② Remove the bushing

Fig18

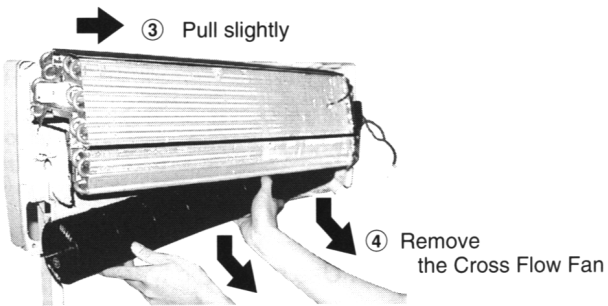

③ Pull slightly

④ Remove the Cross Flow Fan

Fig19



## 12.4.5. Removal procedure of The Control Board

1. Remove the cabinet top plate. (Four screws) (Fig.20)

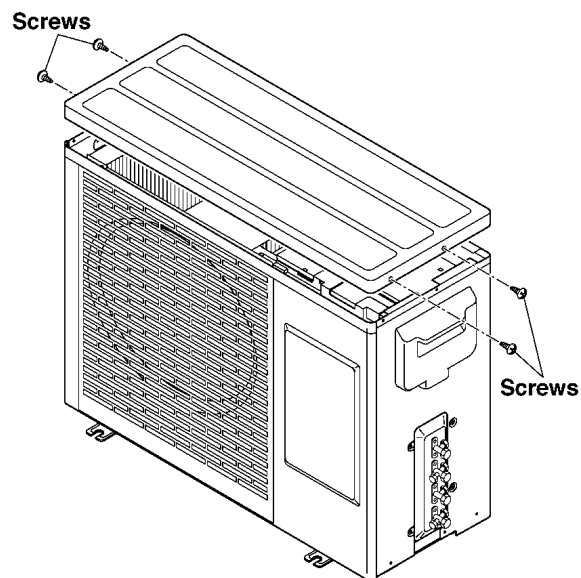

Fig. 20

2. Remove the front grille. (Three screws, Six tabs) (Fig.21)

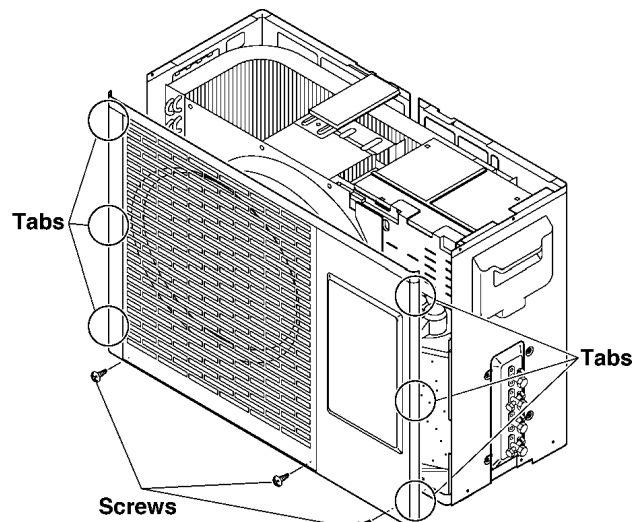

Fig. 21

3. Remove the control board cover (Top). (Four tabs) (Fig.22)

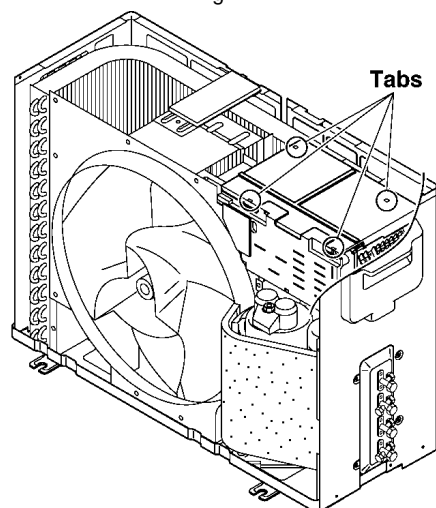

Fig. 22

4. Remove the control board cover (Front). (Three tabs) (Fig.23)

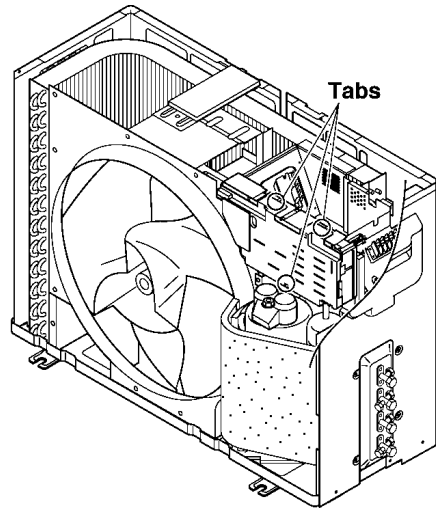

Fig. 23

5. Remove all connectors which are connected to the control board and remove the main control board from the power supply board. (Three screws, Four tabs) (Fig.24)

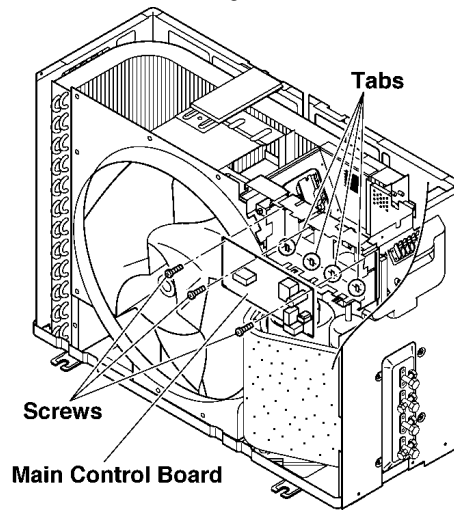

Fig. 24

6. Remove the noise filter. (Six tabs) (Fig.25)

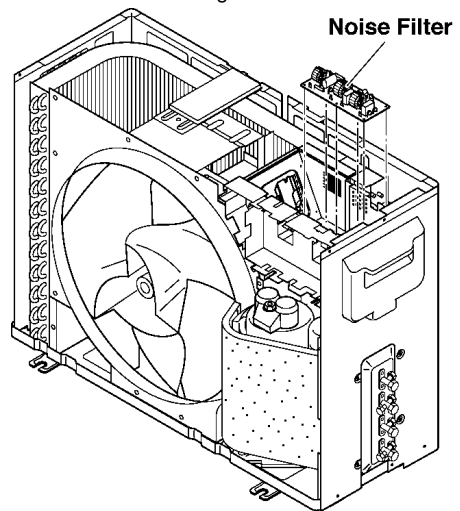

Fig. 25

7. Remove the transistor. (Two screws) (Fig.26)

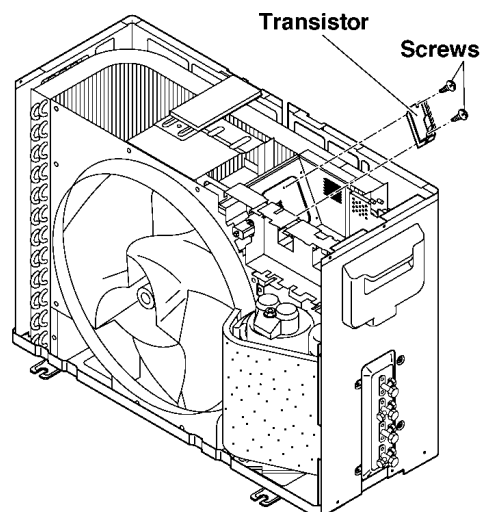

Fig. 26

8. Remove the diode. (One screws) (Fig.27)

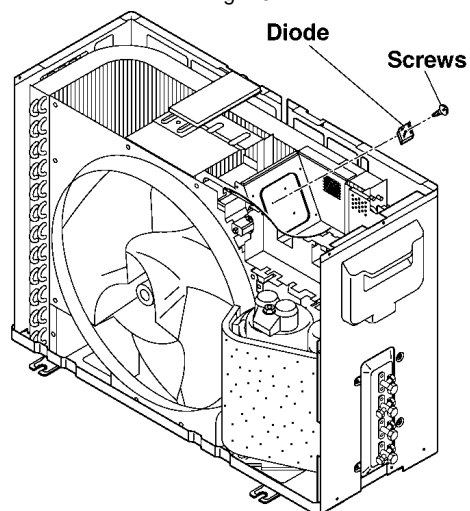

Fig. 27

### 12.4.6. Removal procedure of The Propeller Fan and The Motor

1. Remove the cabinet top plate and the front grille. (Fig.20)

2. Remove the propeller fan by rotating the nut at the center of the fan to the right. (Fig.28)

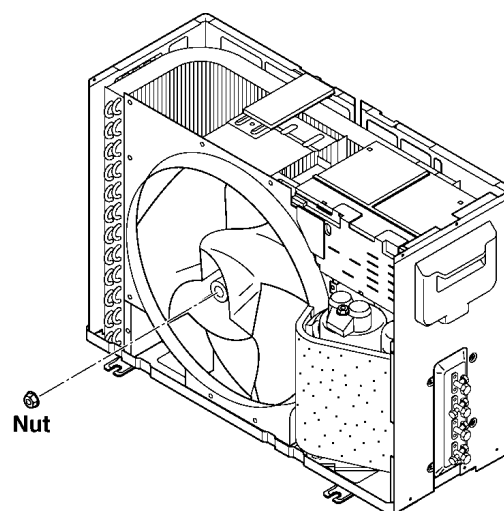

Fig. 28

3. Remove the control board cover (Front). (Fig.23)

4. Remove all connectors which are connected to the motor from the main control board.

5. Remove the motor by releasing four screws. (Fig.29)

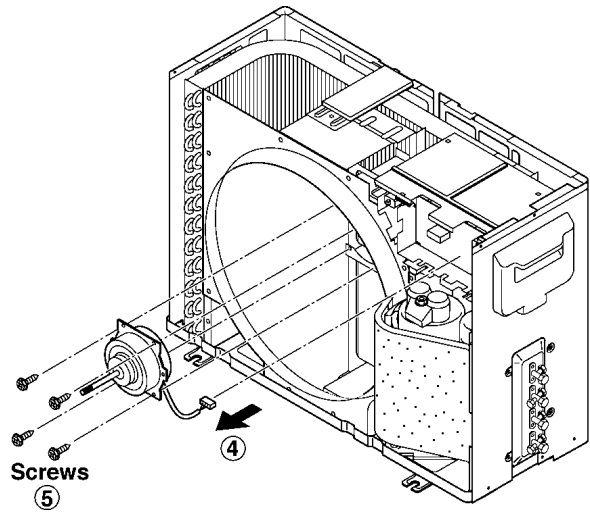

Fig. 29

# 13 Technical Data

## 13.1. OPERATION CHARACTERISTICS

### CS-MVG103KE / CU-MVG153KE

#### One Indoor Unit Operation

##### • Cooling Characteristic (Cooling)

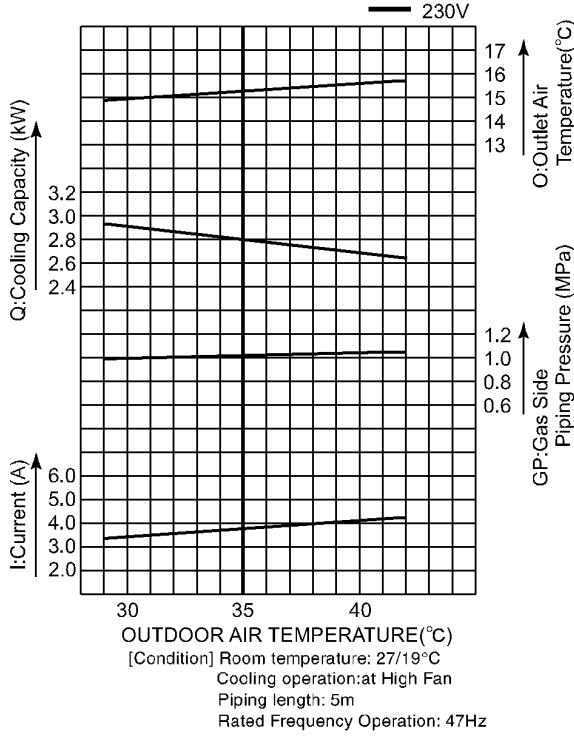

##### • Piping Length Characteristic (Cooling)

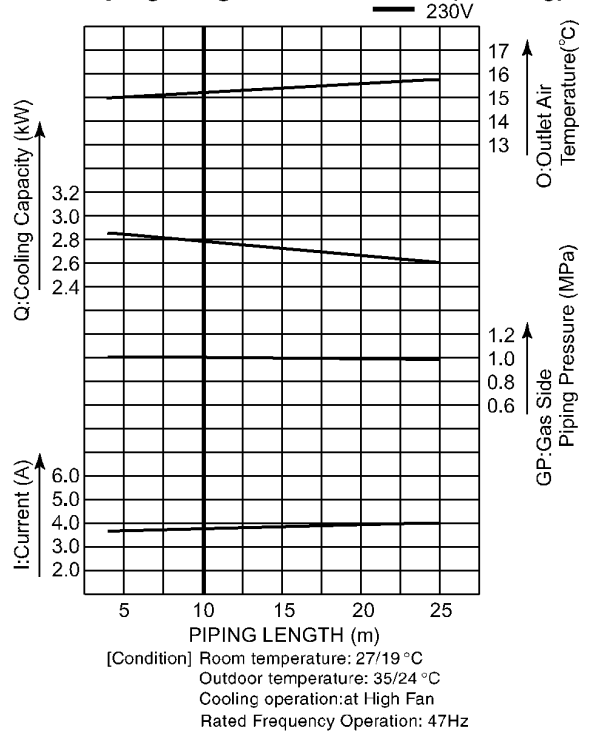

##### • Heating Characteristic (Heating)

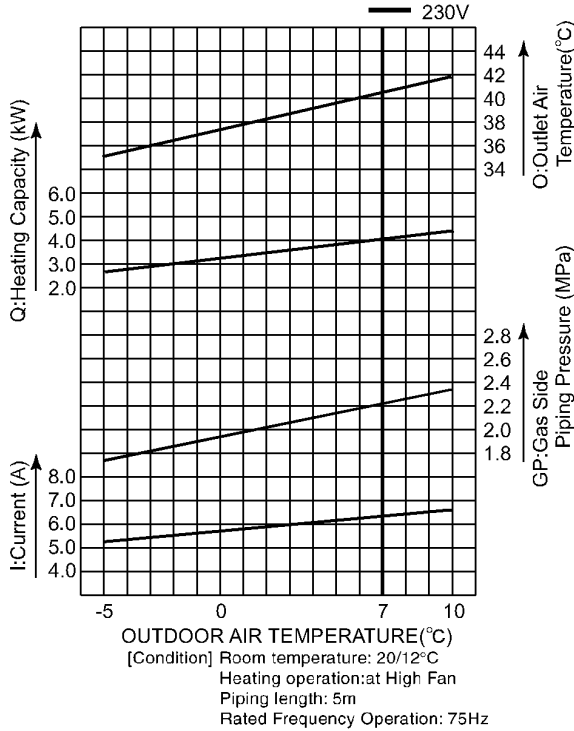

##### • Piping Length Characteristic (Heating)

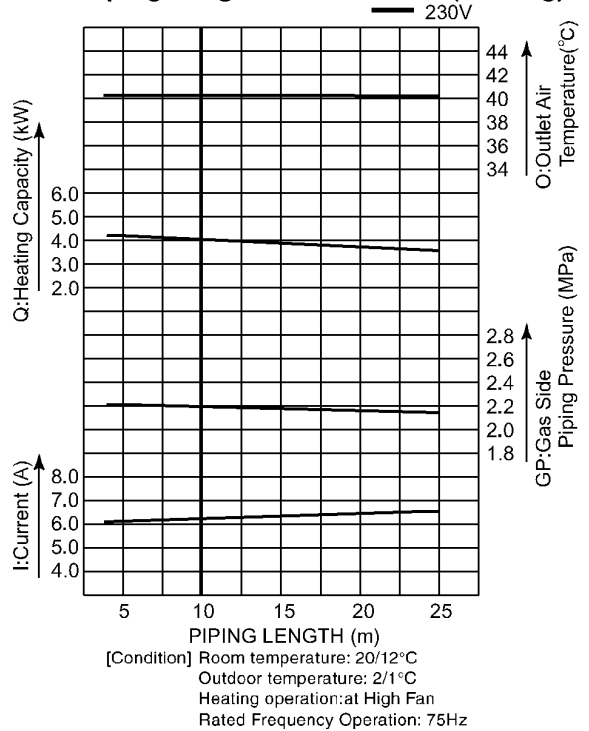

## Two Indoor Units Operation

### • Cooling Characteristic (Cooling)

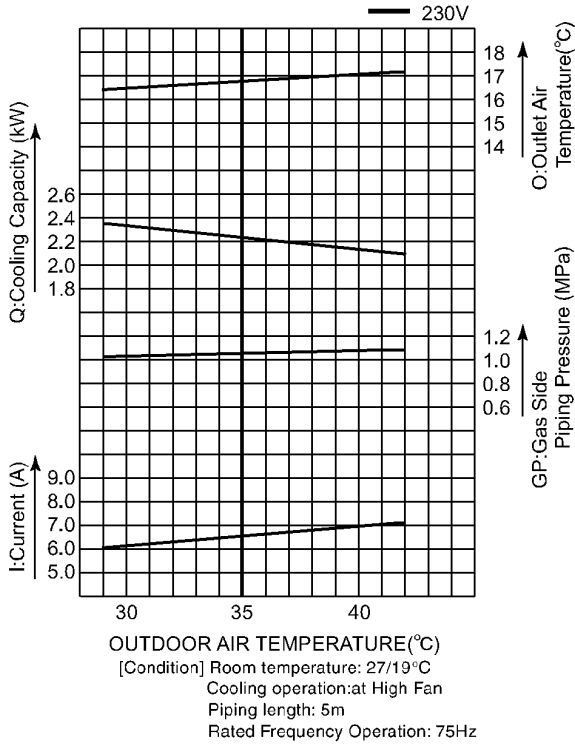

### • Piping Length Characteristic (Cooling)

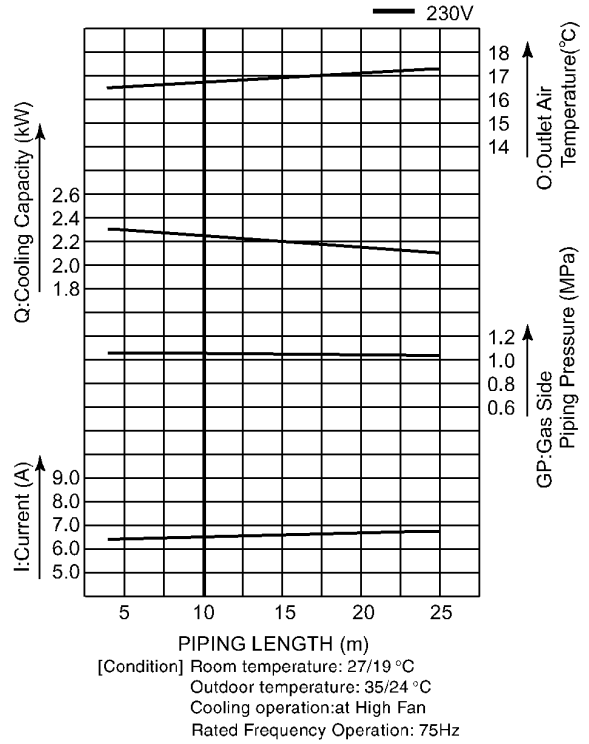

### • Heating Characteristic (Heating)

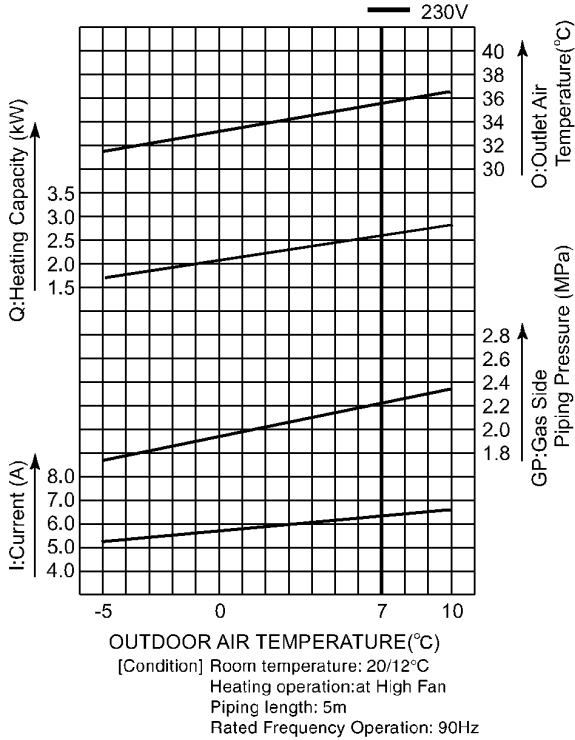

### • Piping Length Characteristic (Heating)

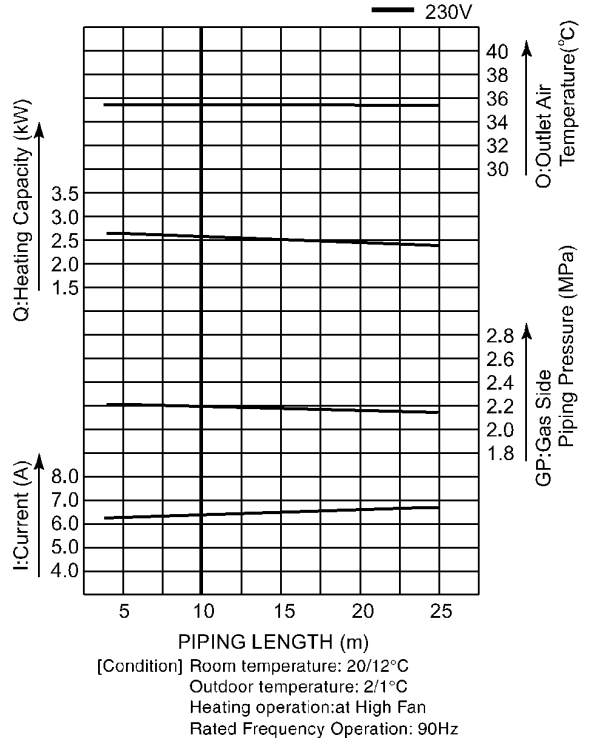

# 14 Electronic Circuit Diagram

## 14.1. HOW TO USE ELECTRONIC CIRCUIT DIAGRAM

Before the circuit diagram, read the following carefully.

### Voltage measurement

voltage has been measured with a digital tester when the indoor fan is set at high fan speed under the following conditions without setting the timer.

Use them for servicing.

Voltage indication is in Red at cooling and all operations.

Voltage indication is in (Red) at heating.

	Intake air temperature	Temperature setting	Discharge air temperature	Pipe temperature
Cooling	27°C	16°C	17°C	15°C
Heating	20°C	30°C	40°C	50°C

### Indications for capacitor

a. Unit       $\mu$  ....  $\mu$ F      P .... pF

### Indications for resistance

a. K ....  $K\Omega$       M ....  $M\Omega$   
W .... wait      Not indicated .... 1/4 W

Diode without indication ..... MA165

※ Circuit Diagram is subject to change without notice for further development.

## 14.2. TIMER TABLE

### 14.2.1. Indoor

Name	Time	Test Mode (When test point Short-circulated)
4 way valve abnormality	4 min.	0
Outdoor air temp. for Hz No. detection	30 min.	0
Anti-freezing Control	6 min.	0
Theorem OFF delay	3 min.	0
Low pressure control ( gas leakage ) compressor OFF time	2 min.	0
Time delay safety control	2 min. 58 sec.	0
Odor timer status shift time	30 sec.	0
	60 sec.	
Hz lock time	30 sec.	0
Self diagnosis display time	10 sec.	0
Auto mode judgement sampling time	58 sec.	0
24 hours ON / OFF timer		1 hour → 1 min.
Hot start forced completion	4 min.	0
Auto mode judgement interval	180 min.	180 sec.
Sleep mode time shift		1 hour → 6 sec.
After Hot start / Deice	2 min.	12 sec.

### 14.2.2. Outdoor

Name	Time	Test Mode (When test point Short-circulated)
DC PEAK	30 sec.	3 sec.
Deice detection	120 min.	24 sec.
	80 min.	18 sec.
	40 min.	8 sec.
	40 min.	8 sec.
Deice forced completion	11 min.	66 sec.
Time delay safety control	3 min.	0
Hz lock time	30 sec.	0
Outdoor fan delay operation control	30 sec.	0
4 way valve delay operation control	3 min.	0
Standy control	ON	3 min.
	OFF	7 min.
		18 sec.
		42 sec.

# 14.3. INDOOR UNIT

## CS-MVG103KE

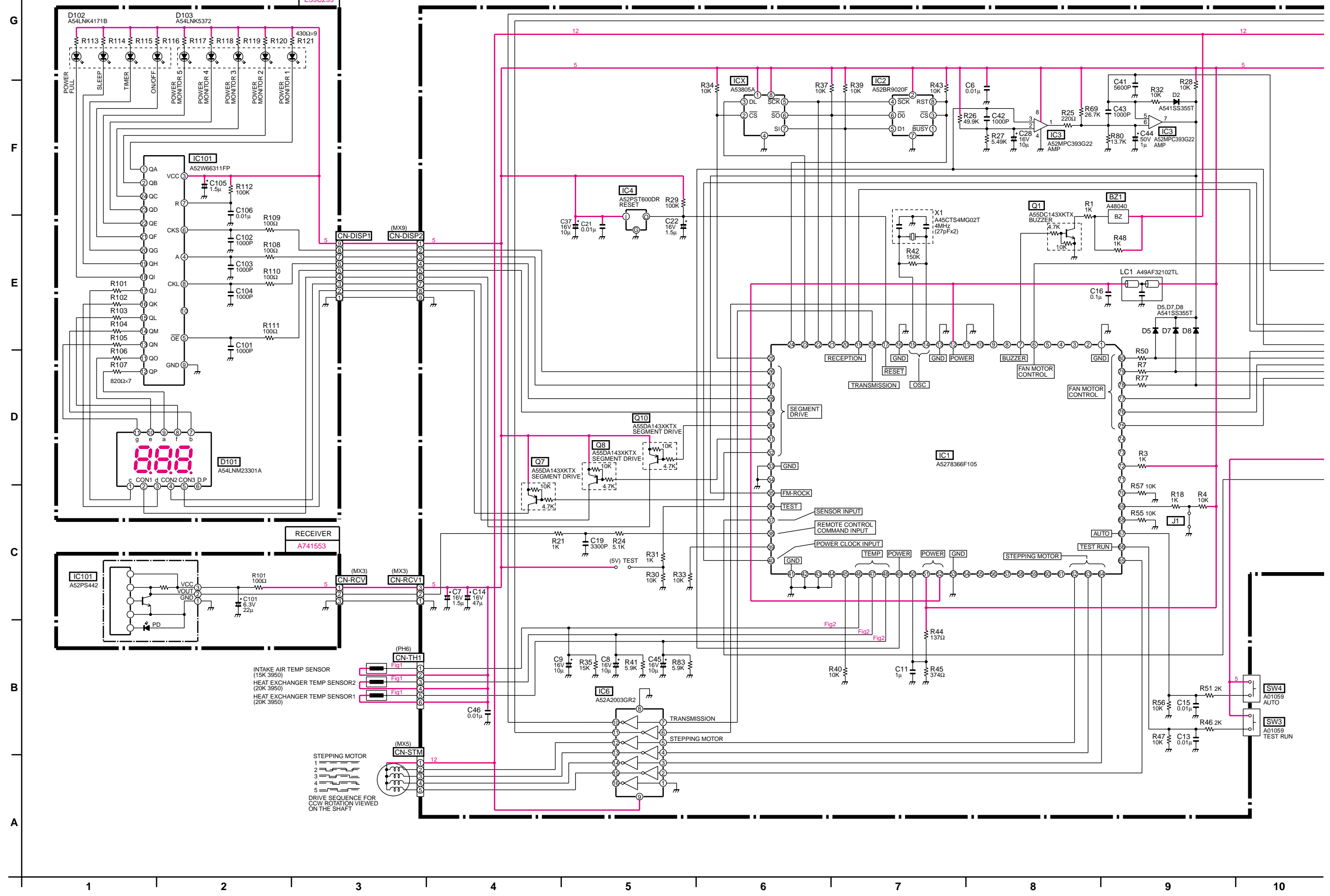



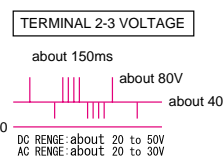
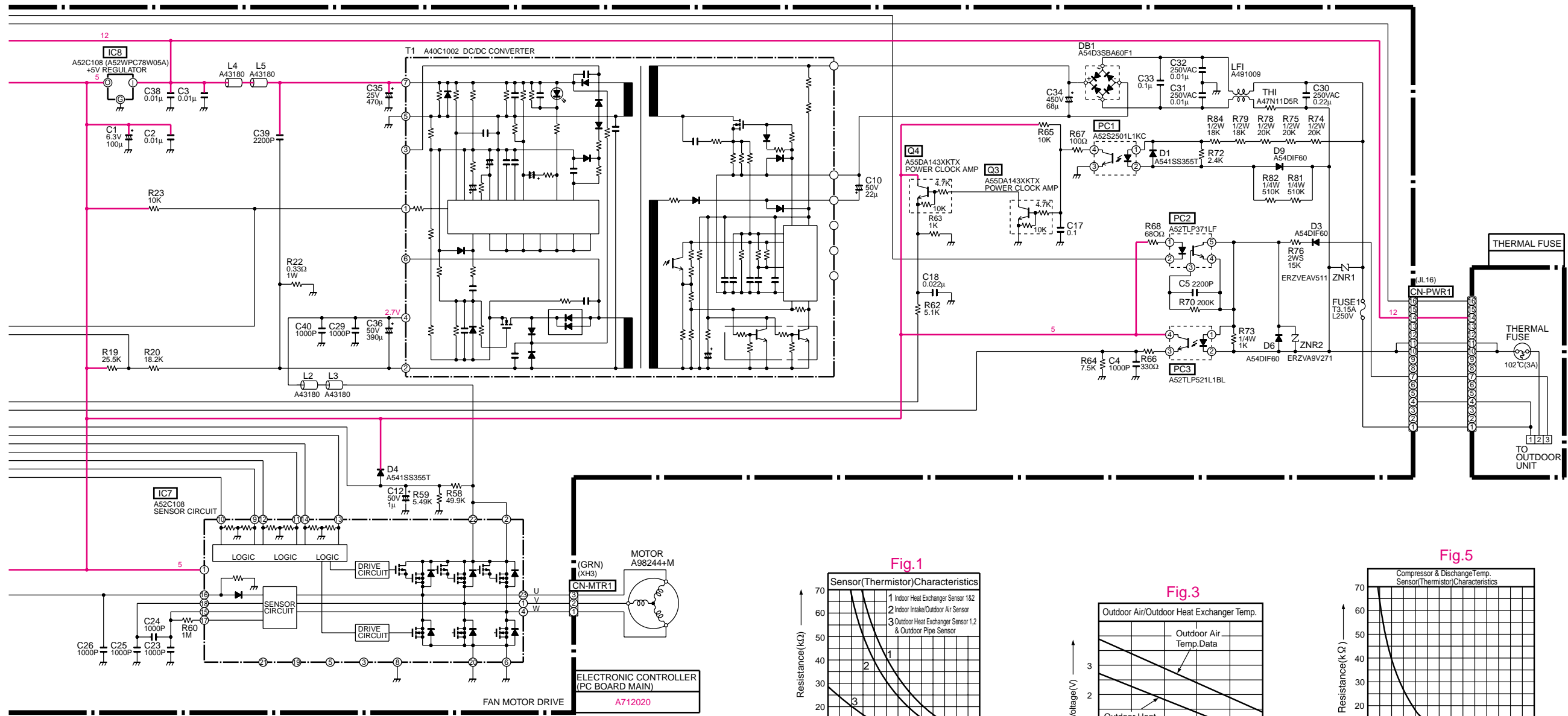

**FAN MOTOR**

Fan level	UV (V)	VW (V)	Between (V)	U-GND (V)	V-GND (V)	W-GND (V)
16V	16	11				
15	15	10				
14	14	9				
13	13	8				
12	12	8				
STOP	0	0				

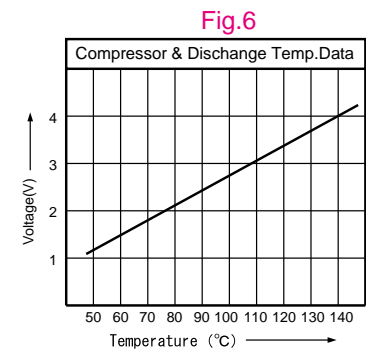
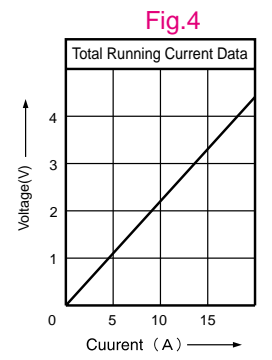
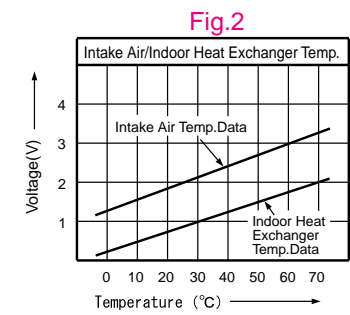
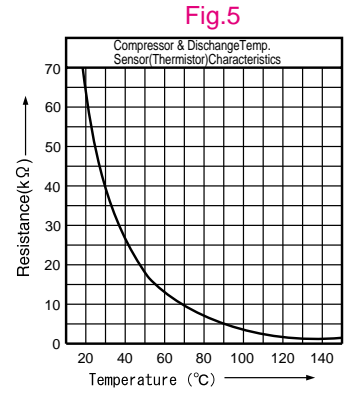
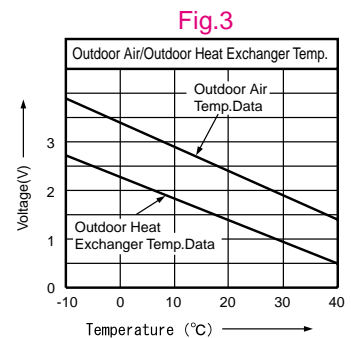
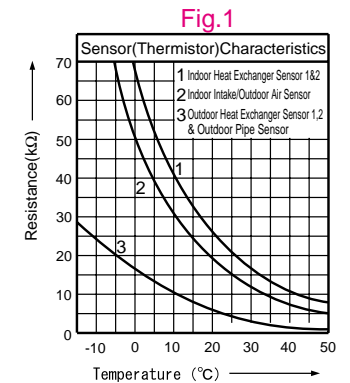

# 14.4. OUTDOOR UNIT

## CU-MVG153KE

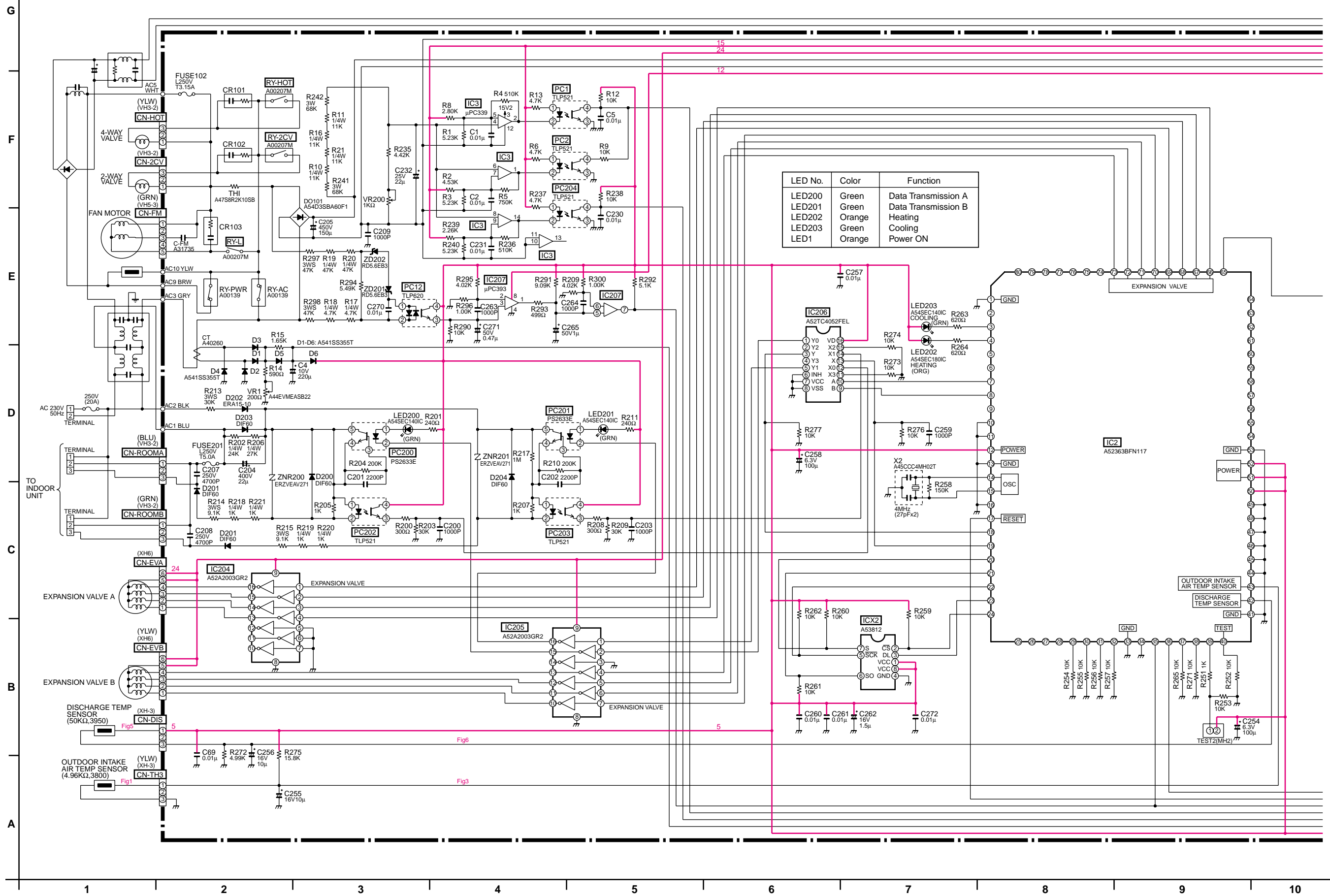

LED No.	Color	Function
LED200	Green	Data Transmission A
LED201	Green	Data Transmission B
LED202	Orange	Heating
LED203	Green	Cooling
LED1	Orange	Power ON

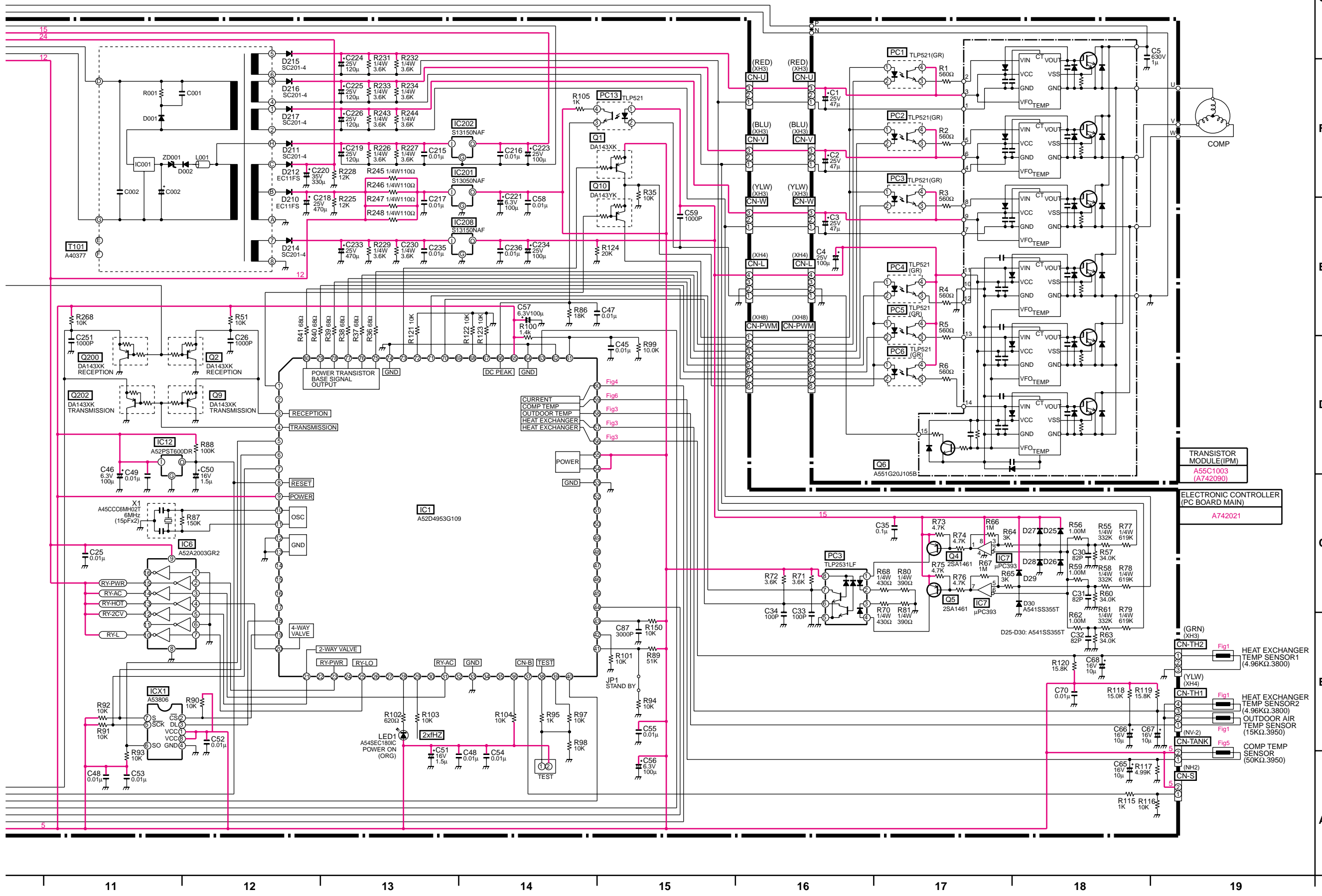

# 14.5. REMOTE CONTROLLER

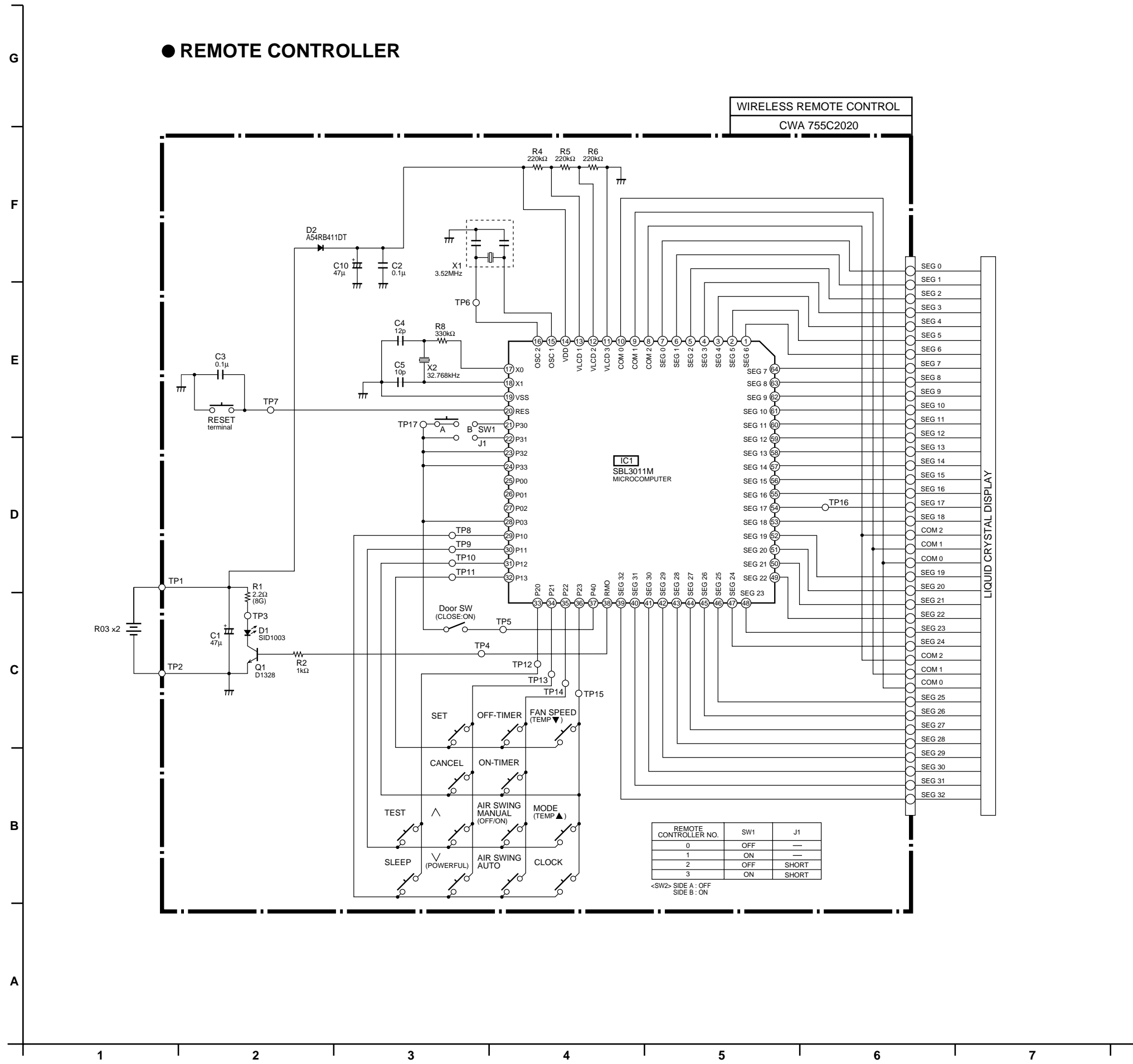

# 15 Printed Circuit Board

## 15.1. INDOOR UNIT

CS-MVG103KE

Main PCB ( Front Side )

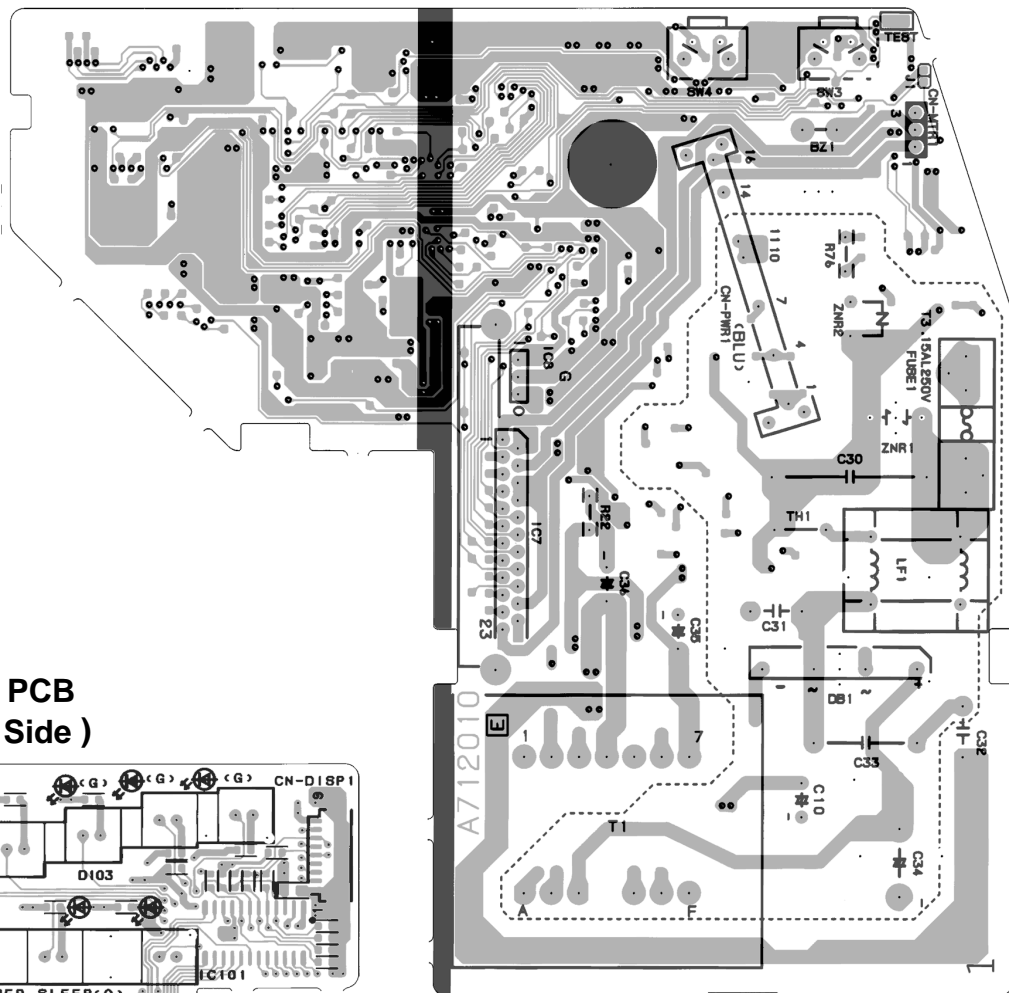

Display PCB  
( Front Side )

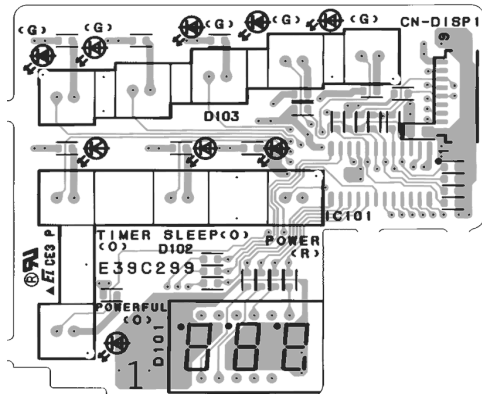

( Back Side )

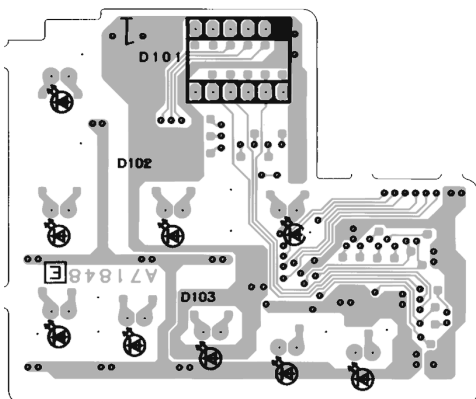

# CS-MVG103KE Main PCB ( Back Side )

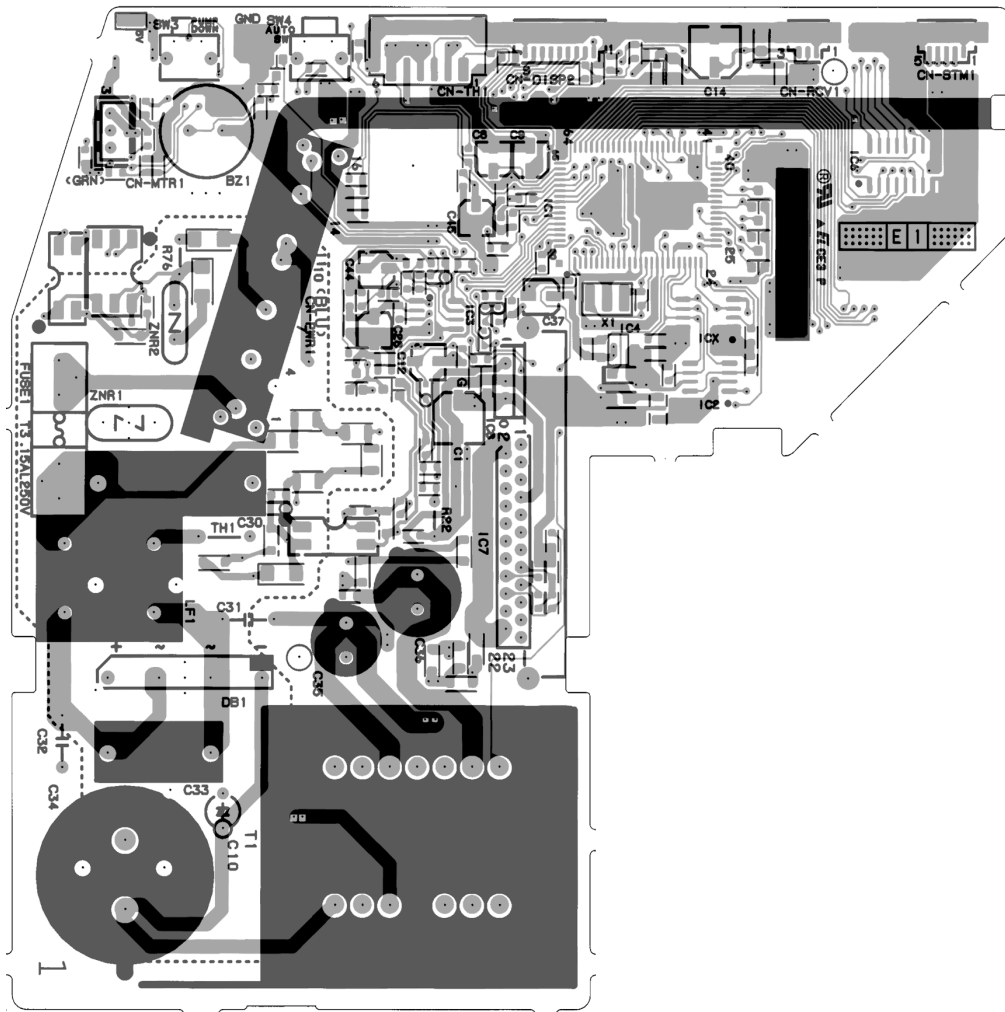

# Receiver PCB

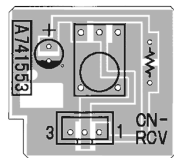

## 15.2. OUTDOOR UNIT / MAIN PCB

CU-MVG153KE

Main PCB ( Front Side )

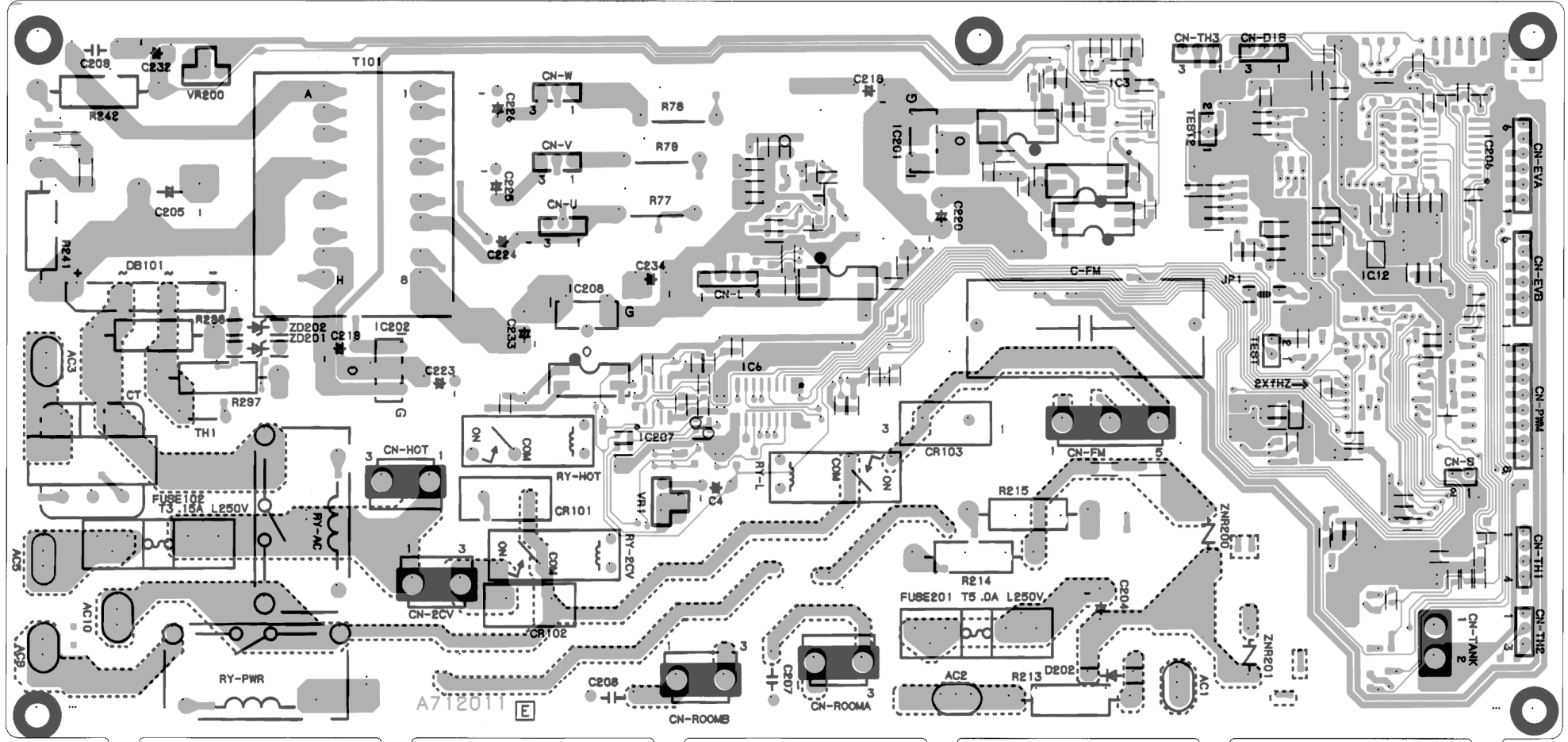

# CU-MVG153KE

## Main PCB ( Back Side )

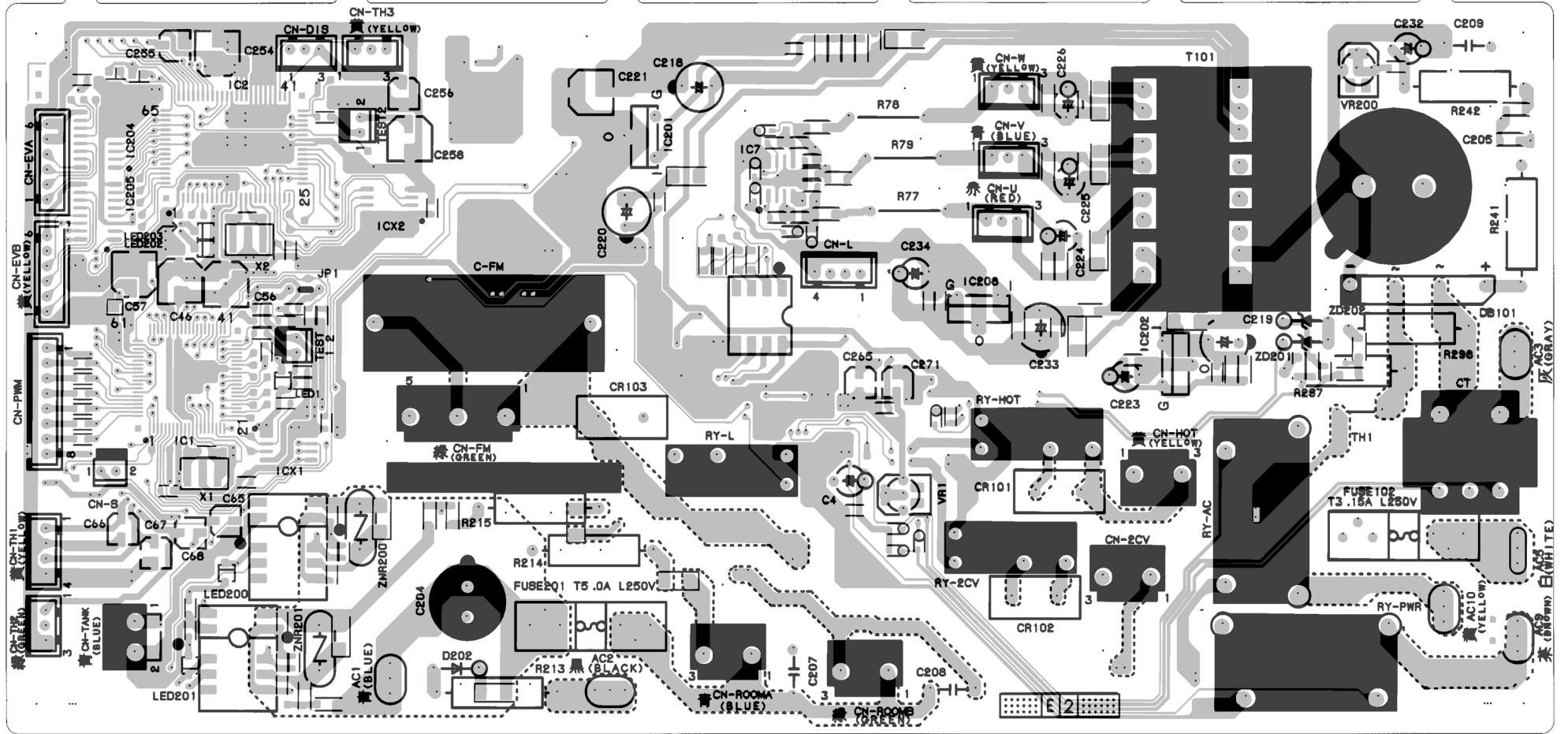



### 15.3. OUTDOOR UNIT / TRANSISTOR MODULE

#### CU-MVG153KE

**Transistor Module PCB  
( Front Side )**

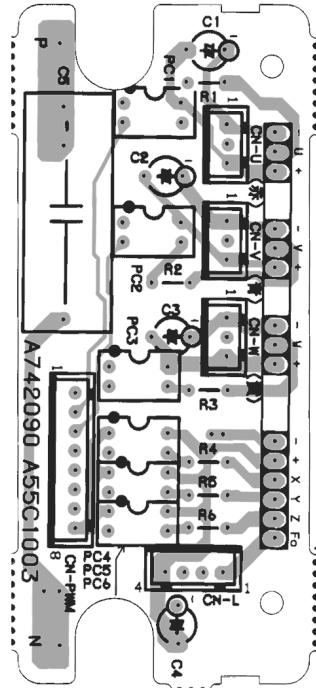

**( Back Side )**

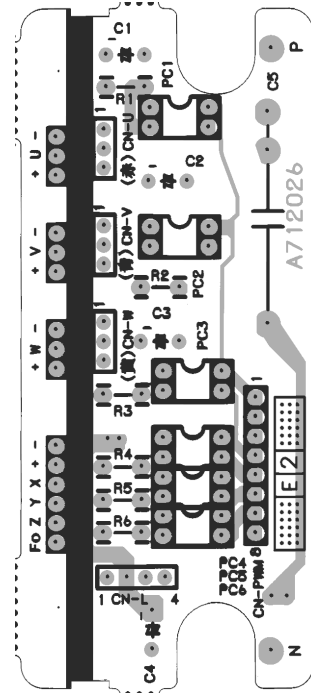

# 16 Exploded View & Replacement Parts List

## 16.1. CS-MVG103KE

### 16.1.1. Exploded View

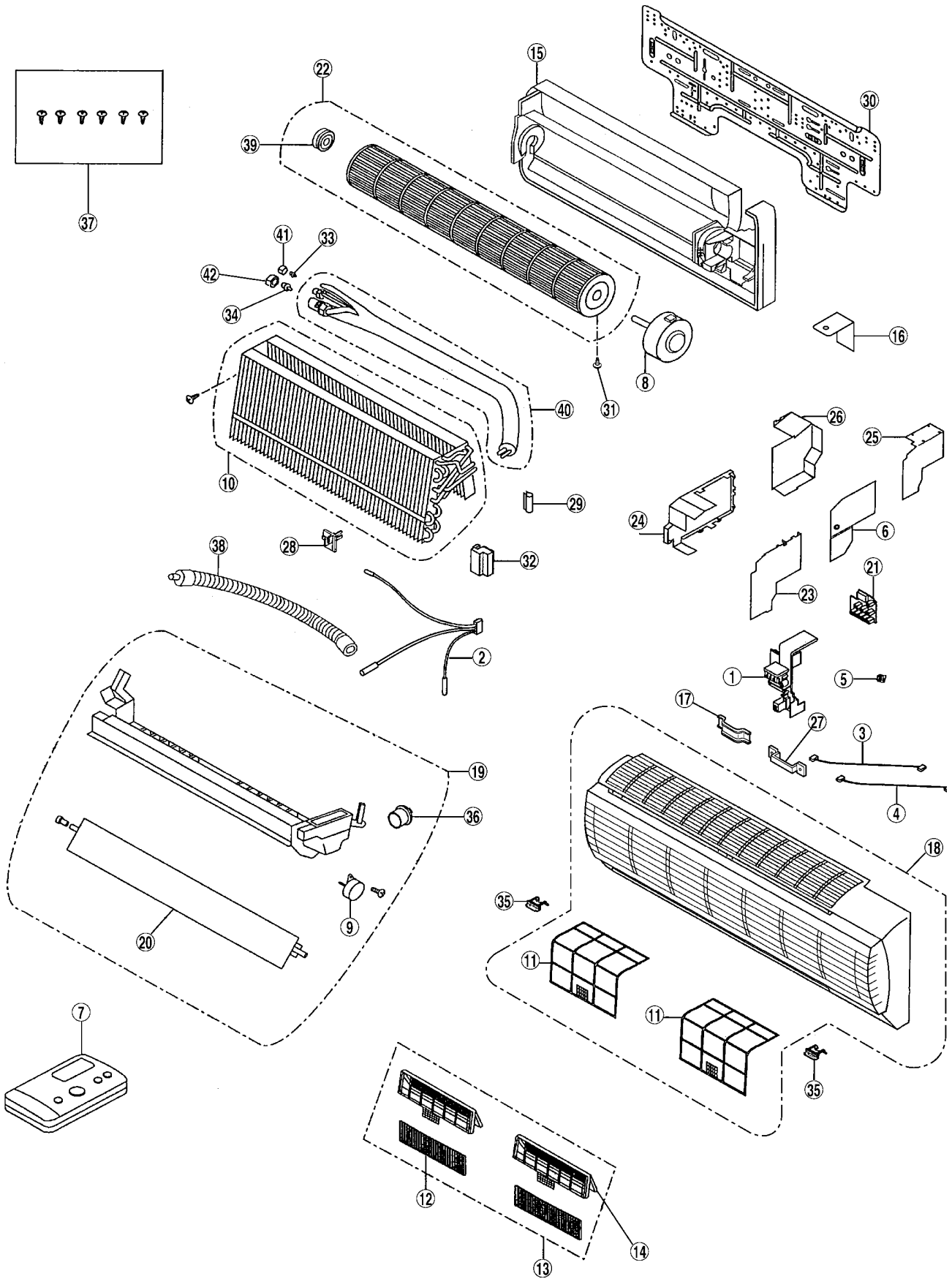

## 16.1.2. Replacement Parts List

No.	CS-MVG103KE	DESCRIPTION & NAME	Q'TY	Remarks
1	CWA28C2004	TERMINAL BOARD COMPLETE	1	M ●
2	CWA50C2023	SENSOR COMPLETE	1	M ●
3	CWA67C2106	LEAD WIRE COMPLETE	1	M
4	CWA67C2310	LEAD WIRE COMPLETE	1	M
5	CWA741553	PC BOARD WITH COMPONENT	1	M ●
6	CWA742020	PC BOARD WITH COMPONENT	1	M ●
7	CWA75C2020	REMOTE CONTROL COMPLETE	1	M ●
8	CWA98244	FAN MOTOR	1	M ●
9	CWA98C033	MOTOR-AIR SWING	1	M ●
10	CWB30C1026	EVAPORATOR	1	M
11	CWD00240	AIR FILTER	2	M
12	CWD00220	AIR PURIFYING FILTER	2	M ●
13	CWD00C111	AIR PURIFYING FILTER COMPLETE	1	M
14	CWD01058	FLAME-AIR PURIFYING FILTER	2	M
15	CWD50C338	CHASSIS COMPLETE	1	M
16	CWD70448	L-PIECE	1	M
17	CWD77001	HOLDER CORD	1	M
18	CWE11C2052	FRONT GRILLE	1	M
19	CWE20C2051	DISCHARGE GRILLE COMPLETE	1	M
20	CWE24462	VANE	1	M
21	CWE39C299	INDICATOR COMPLETE	1	M ●
22	CWH02C060	CROSS-FLOW FAN	1	M
23	CWH13463	CONTROL BOARD COVER	1	M
24	CWH13464	CONTROL BOARD COVER	1	M
25	CWH13465	CONTROL BOARD COVER	1	M
26	CWH13466	CONTROL BOARD COVER	1	M
27	CWH31115	HOLDER CORD	1	M
28	CWH32142	HOLDER SENSOR	1	M
29	CWH32143	HOLDER SENSOR	1	M
30	CWH36157	INSTALLING PLATE	1	M
31	CWH4580304	SCREW	1	M
32	CWH50211	ANTI-VIBRATION BUSHING	1	M
33	CWH52061	CAP	1	M
34	CWH52062	CAP	1	M
35	CWH52160C	CAP	2	M
36	CWH52C003	CAP	1	M
37	CWH82C194	SCREW	1	M
38	CWH5880580	DRAIN PIPE	1	M
39	CWH64K007	FULCRUM	1	M
40	CWT01C2073	TUBE ASSY	1	M
41	CWT25086	FLARE NUT	1	M ●
42	CWT25087	FLARE NUT	1	M ●

### (Note)

- Spare parts are supplied from ;  
" M " is from MACC, Malaysia (Vender code : 086).  
" J " is from Japan.
- " ● " marked parts are recommended to be kept in stock.

## 16.2. CU-MVG153KE

### 16.2.1. Exploded View

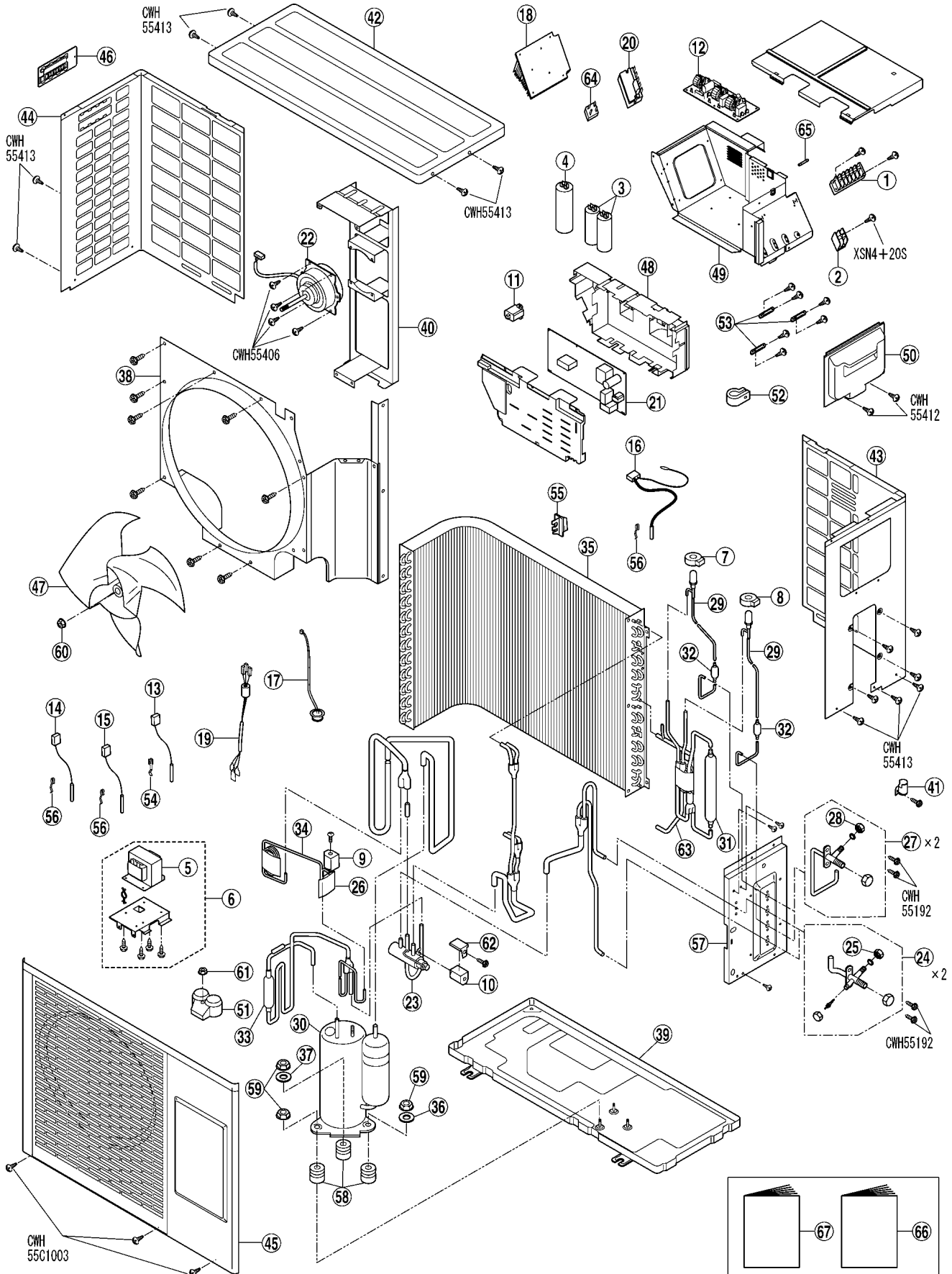

## 16.2.2. Replacement Parts List

No.	CU-MVG153KE	Part Name & Description	Q'TY	Remarks
1	CWA28C2006	TERMINAL BOARD COMPLETE	1	J
2	CWA28K217	TERMINAL BOARD COMPLETE	1	M
3	CWA301029	CAPACITOR	2	J
4	CWA31512	SH CAPACITOR	1	M
5	CWA42136	REACTOR	1	M
6	CWA42C1004	REACTOR COMPLETE	1	J
7	CWA43C2017	EXPANSION VALVE COIL	1	J
8	CWA43C2023	EXPANSION VALVE COIL	1	J
9	CWA43C2024	VALVE COIL	1	J
10	CWA43C2025	VALVE COIL	1	J
11	CWA47038	RESISTOR	1	M
12	CWA491007	NOISE FILTER	1	J
13	CWA50C2024	THERMISTOR (DISCHARGE TEMP)	1	J
14	CWA50C2025	THERMISTOR (AIR TEMP)	1	J
15	CWA50C2026	THERMISTOR (PIPE TEMP)	1	J
16	CWA50C2029	THERMISTOR (PIPE TEMP)	1	J
17	CWA50268	THERMISTOR (COMPRESSOR TEMP)	1	J
18	CWA581009	HEAT SINK	1	J
19	CWA67C3219	LEAD WIRE COMPLETE	1	J
20	CWA55C1003	POWER TRANSISTOR	1	J
21	CWA73C1093	PC BOARD WITH COMPONENT	1	J
22	CWA951026	FAN MOTOR	1	J
23	CWB001006	4-WAY VALVE	1	J
24	CWB011011	3-WAY VALVE	2	J
25	CWT25087	FLARE NUT	2	J
26	CWB021006	2-WAY VALVE	1	J
27	CWB021009	2-WAY VALVE	2	J
28	CWT25086	FLARE NUT	2	J
29	CWB051003	EXPANSION VALVE	2	J
30	CWB092014	COMPRESSOR	1	J
31	CWB101004	DRYER	1	J
32	CWB11094	STRAINER	2	J
33	CWB14010	RECEIVER	1	M
34	CWB15164	CAPILLARY TUBE	1	J
35	CWB32C1025	CONDENSER	1	J
36	CWB81043	PACKING	1	M
37	CWB81047	PACKING	1	M
38	CWD311002	AIR GUIDER P.F	1	J
39	CWD50K2018	CHASSIS COMPLETE	1	J
40	CWD541003	FAN MOTOR BRACKET	1	J
41	CWD791001	HOLDER	1	J
42	CWE031004	CABINET TOP PLATE	1	J
43	CWE041006	CABINET SIDE PLATE	1	J
44	CWE041009	CABINET SIDE PLATE	1	J
45	CWE06C1012	CABINET FRONT PLATE	1	J
46	CWE161001	HANDLE	1	J
47	CWH03K1002	PROPELLER FAN	1	J
48	CWH102017	CONTROL BOARD	1	J
49	CWH10K1003	CONTROL BOARD	1	J
50	CWH131020	CONTROL BOARD COVER	1	J
51	CWH17006	TERMINAL COVER	1	M
52	CWH311001	HOLDER-P.S.CORD	1	J
53	CWH31103	HOLDER-P.S.CORD	3	M
54	CWH32074	HOLDER-SENSOR	1	M
55	CWH32133	HOLDER-SENSOR	1	J
56	CWH32138	HOLDER-SENSOR	3	J
57	CWH351002	HOLDER-COUPPLING	1	J
58	CWH50183	ANTI-VIBRATION BUSHING	3	M
59	CWH56000	NUT	3	M
60	CWH56053	NUT	1	M
61	CWH7080300	NUT	1	M
62	CWH81115	COVER	1	J
63	CWT01C2097	TUBE ASSY(EXPANSION VALVE BLOCK)	1	J
64	A54S25VB60	DIODE	1	M
65	XBACW12	FUSE	1	J
66	CWF563109	OPERATION INSTRUCTIONS	1	J
67	CWF612067	INSTALLATION INSTRUCTIONS	1	J

### (Note)

· Spare parts are supplied from ;

· " " marked parts are recommended to be kept in stock.

"M" is from MACC, Malaysia (Vender code : 086).

"J" is from Japan.

# 17 Electronic Parts List

( Model:CWA742020 ) INDOOR PCB

SYMBOL	PART NO.	DESCRIPTION & NAME	REMARKS
BZ1	A48040	BUZZER	M
D1 ,D2 ,D4 ,D5 ,D7 ,D8	A541SS355T	DIODE	M
D3 ,D6 ,D9	A54DIF60	DIODE	M
DB1	A54D3SBA60F1	DIODE BRIDGE	M
FUSE	XBA2C31TRO	FUSE	M
IC1	A5278366F105	INTERGRATED CIRCUIT	M
IC2	A52BR9020F	INTERGRATED CIRCUIT	M
IC3	A52MPC393G22	INTERGRATED CIRCUIT	M
IC4	A52PST600DR	INTERGRATED CIRCUIT	M
IC5 ,IC6	A52A2003GR2	INTERGRATED CIRCUIT	M
IC7 ,IC8	A52C108	INTERGRATED CIRCUIT	M
ICX	A53805A	INTERGRATED CIRCUIT	M
PC1	A52S2501L1KC	PHOTO COUPLER	M
PC2	A52TLP371LF	PHOTO COUPLER	M
PC3	A52LP521L1BL	PHOTO COUPLER	M
Q1 ,Q3 ,Q4 ,Q7 ,Q8 ,Q10	A55DA143XKTX	TRANSISTOR	M
SW3 ,SW4	A01059	SWITCH	M
T1	A40C1002	TRANSFORMER	M
X1	A45CTS4MG02T	RESONATOR	M
ZNR1	ERZVEAV511	ZNR	M
ZNR2	ERZVA9V271	ZNR	M

( Model:CWA73C1093 ) OUTDOOR PCB

SYMBOL	PART NO.	DESCRIPTION & NAME	REMARKS
C-FM	A31735	CAPACITOR-FM	M
D1 ,D2 ,D3 ,D4 ,D5 ,D6	A541SS355T	DIODE	M
D25 ,D26 ,D27 ,D28 ,D29 ,D30	A541SS355T	DIODE	M
D200 ,D201	A54DIF60	DIODE	M
D202	A54RA15-10V3	DIODE	M
D203 ,D204 ,D205	A54DIF60	DIODE	M
D210	A54EC11FS2TL	DIODE	M
D211	A54SC201-4T	DIODE	M
D212	A54EC11FS2TL	DIODE	M
D214 ,D215 ,D216 ,D217	A54SC201-4T	DIODE	M
ZD201 ,ZD202	A54D5.6EB3TB	ZENAR DIODE	M
PC1 ,PC2	A52LP521L1GB	PHOTO COUPLER	M
PC3	A52TLP2531LF	PHOTO COUPLER	M
PC12	A52LP620L1GB	PHOTO COUPLER	M
PC13	A52LP521L1GB	PHOTO COUPLER	M
PC200 ,PC201	A52PS2633EL	PHOTO COUPLER	M
PC202 ,PC203	A52LP521L1BL	PHOTO COUPLER	M
PC204	A52LP521L1GB	PHOTO COUPLER	M
FUSE102	XBA2C31TRO	FUSE	M
FUSE201	XBA2C50TRO	FUSE	M
IC3	A52MPC339G22	INTERGRATED CIRCUIT	M
IC6	A52A2003GR2	INTERGRATED CIRCUIT	M
IC7	A52MPC393G22	INTERGRATED CIRCUIT	M
IC12	A52PST600DR	INTERGRATED CIRCUIT	M
IC201	A52S13050NAF	INTERGRATED CIRCUIT	M
IC202	A52S13150NAF	INTERGRATED CIRCUIT	M
IC204 ,IC205	A52A2003GR2	INTERGRATED CIRCUIT	M
IC206	A52TC4052FEL	INTERGRATED CIRCUIT	M
IC207	A52MPC393G22	INTERGRATED CIRCUIT	M
IC208	A52S13150NAF	INTERGRATED CIRCUIT	M
ICX1	A53806B	SERIAL PROM	M
ICX2	A53812B	SERIAL PROM	M
Q1 ,Q2	A55DA143XKTX	TRANSISTOR	M
Q4 ,Q5	A55A146ITI	TRANSISTOR	M
Q9	A55DA143XKTX	TRANSISTOR	M
Q10	A55DA143TKTX	TRANSISTOR	M
Q200 ,Q202	A55DA143XKTX	TRANSISTOR	M
LED1	A54SEC180IC	LED	M
LED200 ,LED201	A54SEC140IC	LED	M
LED202	A54SEC180IC	LED	M
LED203	A54SEC140IC	LED	M
VR1	A44EVMASB22	VARIATOR	M
VR200	A44EVMASB13	VARIATOR	M
RY-AC	A00139	RELAY	M

SYMBOL	PART NO.	DESCRIPTION & NAME	REMARKS
RY-L	A00207M	RELAY	M
RY-PWR	A00139	RELAY	M
RY-HOT,RY-2CV	A00207M	RELAY	M
ZNR200,ZNR201	ERZVEAV271	ZNR	M
X1	A45CCC6MH02T	RESONATOR	M
X2	A45CCC4MH02T	RESONATOR	M

**(Note)**

- Spare parts are supplied from ;
- "M" is from MACC, Malaysia (Vender code : 086).
- "J" is from Japan.